

Workshop Manual Audi A3 2004 ➤

Direct petrol injection and ignition system (4-cyl. 2.0 ltr.
4-valve turbo)

Engine ID	AXX	BPY	BWA						
-----------	-----	-----	-----	--	--	--	--	--	--

Edition 11.2005



Audi

Protected by copyright. Copying for private or commercial purposes, in part or in whole, is not permitted unless authorised by AUDI AG. AUDI AG does not guarantee or accept any liability with respect to the correctness of information in this document. Copyright by AUDI AG.



List of Workshop Manual Repair Groups

Repair Group

24 - Mixture preparation - injection

28 - Ignition system



Protected by copyright. Copying for private or commercial purposes, in part or in whole, is not permitted unless authorised by AUDI AG. AUDI AG does not guarantee or accept any liability with respect to the correctness of information in this document. Copyright by AUDI AG.



Technical information should always be available to the foremen and mechanics, because their careful and constant adherence to the instructions is essential to ensure vehicle road-worthiness and safety. In addition, the normal basic safety precautions for working on motor vehicles must, as a matter of course, be observed.

Contents

24	Mixture preparation - injection	1
1	Servicing injection system	1
1.1	General notes on self-diagnosis	1
1.2	Safety precautions	1
1.3	Rules for cleanliness	2
1.4	Procedure to be followed prior to opening high-pressure injection system - take note of the following:	3
1.5	Technical data	4
1.6	Overview - fitting locations	5
1.7	Exploded view - intake manifold	13
1.8	Exploded view - fuel rail	15
1.9	Exploded view - air cleaner / engine cover panel	16
1.10	Removing and installing engine cover panel with air filter element	16
1.11	Removing and installing intake manifold with fuel rail	18
1.12	Removing and installing injectors	22
1.13	Checking initial fuel pressure (up to high-pressure pump)	26
1.14	Checking fuel pressure and residual pressure (up to high-pressure pump)	28
1.15	Exploded view - high-pressure fuel pump	31
1.16	Removing and installing high-pressure fuel pump	32
1.17	Wiring and component check with test box V.A.G 1598/42	34
1.18	Renewing Motronic control unit J220	36
1.19	Removing and installing Lambda probe G39 and Lambda probe heater Z19 before catalytic converter	39
1.20	Removing and installing Lambda probe after catalytic converter G130 and Lambda probe 1 heater, after catalytic converter Z29	39
28	Ignition system	41
1	Checking ignition system	41
1.1	General notes on ignition system	41
1.2	Safety precautions	41
1.3	Technical data for ignition system	41
2	Ignition system - exploded view of components	42
3	Removing and installing ignition coils with output stages	43

Protected by copyright. Copying for private or commercial purposes, in part or in whole, is not permitted unless authorized. Audi AG does not guarantee or accept any liability with respect to the correctness of information in this document. Copyright by AUDI AG.

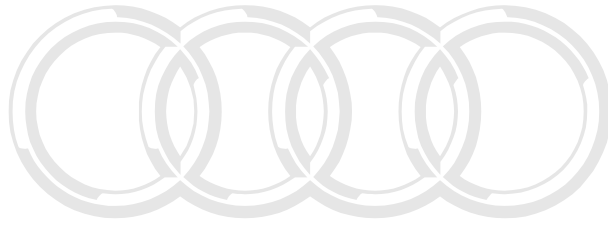

Audi

Protected by copyright. Copying for private or commercial purposes, in part or in whole, is not permitted unless authorised by AUDI AG. AUDI AG does not guarantee or accept any liability with respect to the correctness of information in this document. Copyright by AUDI AG.



24 – Mixture preparation - injection

1 Servicing injection system

1.1 General notes on self-diagnosis

- ◆ The engine control unit has a self-diagnosis capability. Before carrying out repairs and fault finding the fault memory must be interrogated. The vacuum hoses and connections must also be checked (unmetered air).
- ◆ Fuel hoses in engine compartment must only be secured with spring-type clips. Clamping-type or screw-type clips must not be used.
- ◆ A voltage of at least 11.5 V is required for proper operation of the electrical components.
- ◆ Do not use sealants containing silicone. Particles of silicone drawn into the engine will not be burnt in the engine and will damage the Lambda probe.
- ◆ The vehicles are fitted with a crash/fuel shut-off system. This system is designed to reduce the risk of a vehicle fire after a crash by deactivating the fuel pump via the fuel pump relay.
- ◆ At the same time, this system also improves the engine's starting performance. When the driver's door is opened, the fuel pump is activated for 2 seconds in order to build up pressure in the fuel system → [Chapter \(page 1\)](#).

1.2 Safety precautions



WARNING

The fuel system is pressurised. The fuel pressure in the high-pressure part of the injection system must be reduced to a residual pressure prior to opening; for procedure see → [Chapter \(page 3\)](#).

The connection must be opened IMMEDIATELY after reducing the pressure by wrapping a cloth around the connection and allowing the residual pressure (approx. 6 bar) to dissipate.

Note the following if testers and measuring instruments have to be used during a road test:



WARNING

- ◆ *Test equipment must always be secured on the rear seat and operated from that position by a second person.*
- ◆ *If test and measuring instruments are operated from front passenger's seat and the vehicle is involved in an accident, the person sitting in this seat could be seriously injured when the airbag is triggered.*



To avoid any risk of injuries to persons and/or damage to the fuel injection and ignition system, always observe the following safety precautions.

- ◆ If the battery is not disconnected, fuse No. 27 for fuel pump control unit -J538- must be removed as a precautionary measure before opening the fuel system, because the fuel pump will otherwise be activated by the contact switch on the driver's door.
- ◆ Persons wearing a cardiac pacemaker must at all times maintain a safe distance from high-voltage components such as the ignition system and gas-discharge headlights.
- ◆ Do not open any fuel line connections while the engine is running.
- ◆ Always switch off the ignition before connecting or disconnecting injection or ignition system wiring or tester cables.
- ◆ If engine is to be operated at cranking speed without it starting (e.g. compression test), unplug connectors from ignition coils and remove fuse for electric fuel pump.
- ◆ Certain tests may lead to a fault being detected by the control unit and stored. The fault memory should therefore be interrogated and (if necessary) erased after completing the tests and any repair work that may be required.
- ◆ If the fault memory has been erased, you must generate the readiness code again.
- ◆ Always switch off the ignition before cleaning the engine.
- ◆ Always switch off the ignition before connecting or disconnecting the battery, otherwise the engine control unit may be damaged.
- ◆ If the engine has to be operated at the starting speed without actually starting (e.g. to test compression pressure), detach the four connectors from the ignition coils using assembly tool -T40039- → [Chapter \(page 43\)](#). Also remove fuse 27 from fuel pump control unit -J538- .

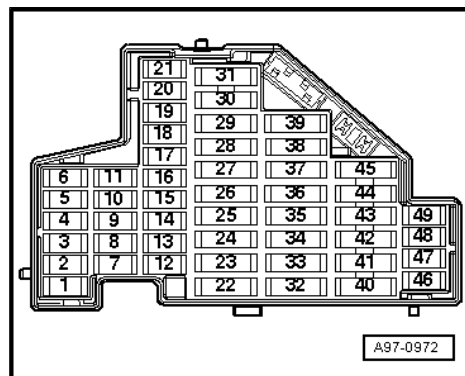

Note

- ◆ Removing fuse 27 will interrupt the voltage supply for the fuel pump control unit -J538- .

1.3 Rules for cleanliness

When working on the fuel supply/injection system, pay careful attention to the following "6 rules":

- ◆ Thoroughly clean all unions and the adjacent areas before disconnecting.
- ◆ Place parts that have been removed on a clean surface and cover them over. Do not use fluffy cloths.
- ◆ Carefully cover or seal open components if repairs cannot be carried out immediately.
- ◆ Only install clean components; replacement parts should only be unpacked immediately prior to installation. Do not use parts that have been previously unpacked and stored away loose (e.g. in toolboxes, etc.).
- ◆ When the system is open: Do not work with compressed air. Do not move vehicle.

- ◆ Unplugged electrical connectors; keep them clean and dry. Make sure connections are dry when attaching.

1.4 Procedure to be followed prior to opening high-pressure injection system - take note of the following:



Caution

The injection system consists of a high-pressure section (maximum approx. 120 bar) and a low-pressure section (approx. 6 bar).

Prior to opening the high-pressure section (e.g. when removing the high-pressure pump, fuel rail, injectors, fuel pipes or fuel pressure sender -G247-, the fuel pressure in the high-pressure section must be reduced to a residual pressure of approx. 6 bar. The appropriate procedure is described below.

permitted unless authorised by AUDI AG. AUDI AG does not guarantee or accept any liability with respect to the correctness of information in this document. Copyright by AUDI AG.

Reducing fuel pressure in high-pressure section

- Detach electrical connector at fuel pressure regulating valve -N276- -2- .
- Allow engine to idle for about 10 seconds.



Note

- ◆ *Fuel pressure will be reduced from approx. 50 bar to approx. 6 bar when electrical connector is detached from fuel pressure regulating valve -N276- while engine is idling.*
- Switch off ignition.

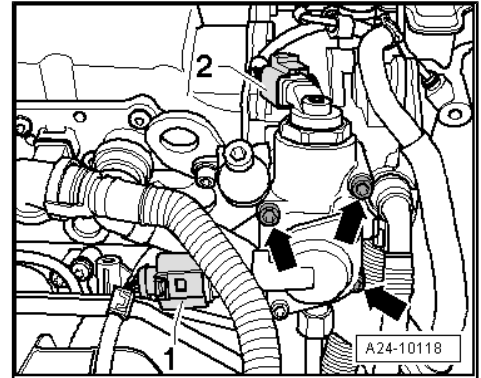

WARNING

The fuel lines are still filled with fuel, however the fuel is no longer under high pressure. Wear safety goggles and protective clothing when opening the fuel system to avoid possible injury and skin contact.

Before opening the high-pressure section, wrap a cloth around the connection.

- The high-pressure system must be opened IMMEDIATELY after reducing the pressure by wrapping a clean cloth around the connection and allowing the residual pressure (approx. 6 bar) to dissipate. Any discharged fuel must be collected.
- Upon completion of repair work, interrogate fault memory of engine control unit and erase any error entries caused by detaching the electrical connector.
- Generate readiness code in engine control unit in "Guided fault finding" mode.

**Note**

- ◆ *You can watch the fuel pressure dropping by connecting a fault reader and selecting the engine control unit. Select function "Read measured value block" and display group 140.*
- ◆ *The fuel pressure (actual value) is displayed in zone 3.*

1.5 Technical data

Engine data		2.0 ltr. / 147 kW turbo FSI engine
Idling speed is not adjustable; controlled by the idling speed stabilisation		640 ... 800 rpm
Speed governing by deactivation of fuel injectors		6500 rpm
Fuel pressure	Fuel pre-pressure up to high-pressure pump (generated by electric fuel pump in fuel tank)	approx. 6.0 bar (identical for all operating conditions)
	Fuel high-pressure (generated by mechanical single-plunger pump) at a coolant temperature of approx. 85° C.	approx. 49 bar at idling speed approx. 120 bar in certain parts of operating range.



Audi

Protected by copyright. Copying for private or commercial purposes, in part or in whole, is not permitted unless authorised by AUDI AG. AUDI AG does not guarantee or accept any liability with respect to the correctness of information in this document. Copyright by AUDI AG.



erWin

1.6 Overview - fitting locations

Components A to Q are not shown in the exploded view.

1 - Solenoid valve for charge pressure control -N75-

- Located directly on turbocharger
→ [Fig. \(page 12\)](#)

2 - Turbocharger divert air valve -N249-

- Located directly on turbocharger
→ [Fig. \(page 12\)](#)

3 - Motronic control unit -J220-

- Removing and installing
→ [Chapter \(page 36\)](#)

4 - Ignition coils with output stages

- Removing and installing
→ [Chapter \(page 43\)](#)
- Ignition coil 1 with output stage -N70-
- Ignition coil 2 with output stage -N127-
- Ignition coil 3 with output stage -N291-
- Ignition coil 4 with output stage -N292-
- Puller -T40039- is required for removing ignition coils from cylinder head.

5 - Lambda probe -G39- and Lambda probe heater -Z19-

- Removing and installing
→ [Chapter \(page 39\)](#)

6 - Fuel pressure sender for low-pressure section -G410-

- Tightening torque: 15 Nm

7 - Fuel pressure regulating valve -N276-

8 - Inlet camshaft timing adjustment valve -1- -N205-

- Removing and installing → [Rep. Gr. 15](#)

9 - Coolant temperature sender -G62-

- [Fig. \(page 7\)](#)

10 - 6-pin connector

- For Lambda probe -G39- and Lambda probe heater -Z19- (black) → [Fig. \(page 9\)](#)

11 - Single-plunger high-pressure pump

- Removing and installing → [Chapter \(page 32\)](#)

12 - Radiator outlet coolant temperature sender -G83-

- [Fig. \(page 9\)](#)

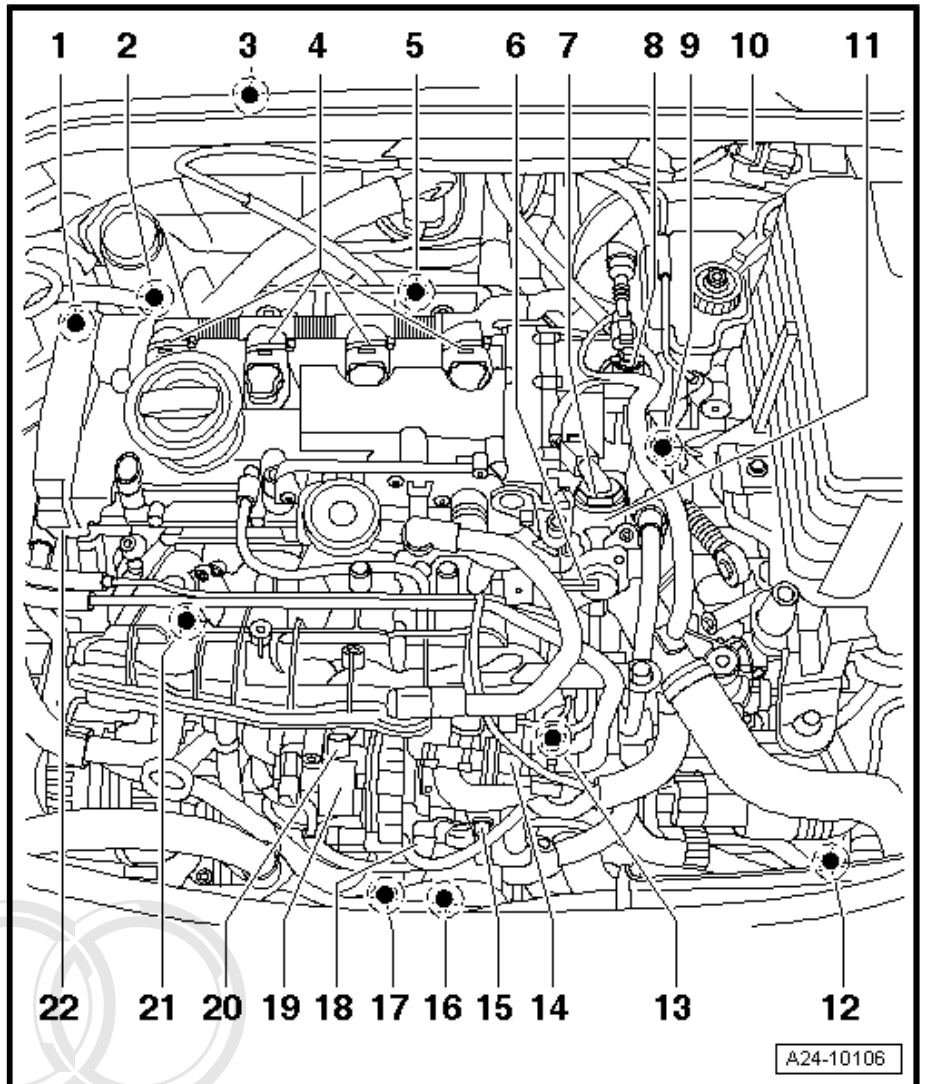

**13 - Intake manifold flap motor -V157- with intake manifold flap potentiometer -G336-**

- After the fuel rail has been renewed, intake manifold flap potentiometer -G336- must be re-adapted to the Motronic control unit -J220- → Vehicle diagnosis, testing and information system VAS 5051; or Guided Functions

14 - Solenoid valve 1 for activated charcoal filter -N80-**15 - Connector**

- For Hall sender -G40- and fuel pressure sender -G247-
- [Fig. \(page 11\)](#)

16 - Charge pressure sender -G31-

- [Fig. \(page 11\)](#)

17 - Engine speed sender -G28-

- [Fig. \(page 11\)](#)

18 - 8-pin connector for injectors

- [Fig. \(page 11\)](#)

19 - Throttle valve module -J338- , throttle valve drive for electric throttle operation -G186-

- Angle sender 1 for throttle valve drive (electric throttle operation) -G187- and angle sender 2 for throttle valve drive (electric throttle operation) -G188-
- After the throttle valve module -J338- has been renewed, it must be re-adapted to the Motronic control unit -J220- (Basic setting, Display group 60), see → Vehicle diagnosis, testing and information system VAS 5051; or Guided Functions

20 - Intake air temperature sender -G42-**21 - Fuel pressure sender -G247-**

- Tightening torque: 22 Nm
- [Fig. \(page 8\)](#)

22 - Hall sender -G40- (camshaft position sensor)

- Electrical connector → [Fig. \(page 8\)](#)

A - Diagnostic connector

- In driver's knee restraint

B - Air mass meter -G70-

- In air cleaner (top section) → [Fig. \(page 8\)](#)

C - Fuel pump control unit -J538-

- [Fig. \(page 8\)](#)
- Adaption must be performed after renewing fuel pump control unit -J538-. Basic setting, measured value block 103, refer to → Rep. Gr. 20

D - "EPC" warning lamp

- In dash panel insert

E - "MIL" exhaust emissions warning lamp

- In dash panel insert

F - Lambda probe after catalytic converter -G130- and Lambda probe heater 1 after catalytic converter -Z29-

- [Fig. \(page 9\)](#)
 - Removing and installing → [Chapter \(page 39\)](#)
- Protected by copyright. Copying for private or commercial purposes, in part or in whole, is not permitted unless authorised by AUDI AG. AUDI AG does not guarantee or accept any liability with respect to the correctness of information in this document. Copyright by AUDI AG.

G - Brake light switch - F- and brake pedal switch -F63-

- [Fig. \(page 10\)](#)

H - Accelerator position sender -G79- and accelerator position sender 2 -G185-

- On accelerator pedal (both senders are accommodated in one housing)
- [Fig. \(page 10\)](#)

I - Clutch position sender -G476-

- [Fig. \(page 10\)](#)

J - Relay and fuse carrier in electronics box

- [Fig. \(page 11\)](#)

K - Radiator fan control unit -J293-

- Fitted on left-side radiator fan (in direction of travel)

L - Injectors

- In fuel rail
- Removing and installing → [Chapter \(page 22\)](#)
- Injector, cylinder 1 -N30-
- Injector, cylinder 2 -N31-
- Injector, cylinder 3 -N32-
- Injector, cylinder 4 -N33-

The fuel injectors are high-pressure injectors. They inject fuel at high pressure (maximum approx. 120 bar) directly into the cylinder.

Protected by copyright. Reproduction for private or commercial purposes, in part or in whole, is not permitted unless authorised by AUDI AG. AUDI AG does not guarantee or accept any liability with respect to the correctness of information in this document. Copyright by AUDI AG.

M - 3-pin connector for knock sensor 1 -G61-

- [Fig. \(page 11\)](#)

N - 3-pin connector for knock sensor 2 -G66-

- [Fig. \(page 11\)](#)

O - Knock sensor 1 -G61-

- For cylinders 1 and 2
- Tightening torque: 20 Nm
- [Fig. \(page 11\)](#)

P - Knock sensor 2 -G66-

- For cylinders 3 and 4
- Tightening torque: 20 Nm
- [Fig. \(page 11\)](#)

Q - Oil pressure sender -G10-

- [Fig. \(page 11\)](#)

Coolant temperature sender -G62- -1-

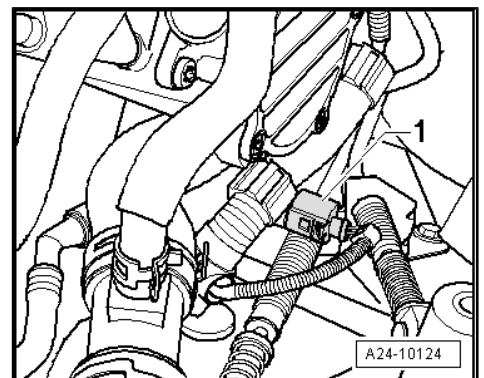



Fuel pressure sender -G247- -1- (tightening torque: 22 Nm)

- Make sure that connecting piece is tightened to specified torque "30 Nm" before installing fuel pressure sender -G247-

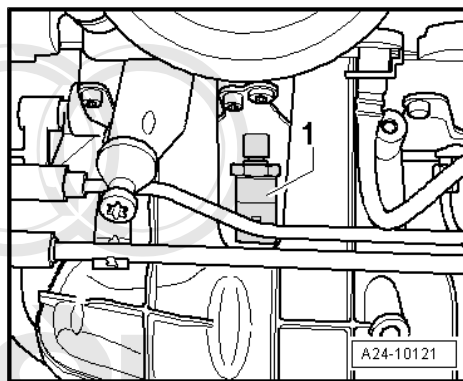

Hall sender -G40- -1-

Protected by copyright. Copying for private or commercial purposes in any form or in any way is not permitted unless authorised by AUDI AG. AUDI AG does not guarantee or accept any liability with respect to the correctness of information in this publication. Copyright © by AUDI AG.

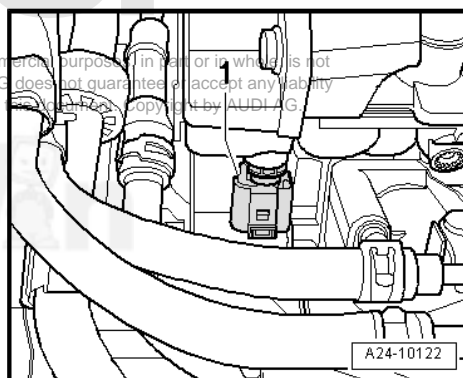

Air mass meter -G70- -1-

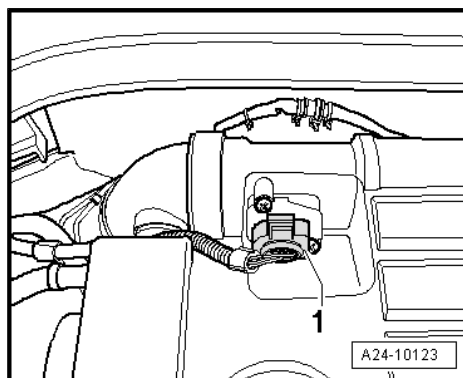

Fuel pump control unit -J538- -1-

- Adaption must be performed after renewing fuel pump control unit -J538-. Basic setting, measured value block 103, refer to → Rep. Gr. 20

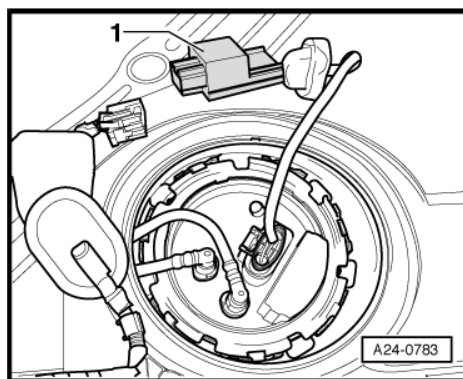

Electrical connector

1 - Lambda probe -G39- and Lambda probe heater -Z19-

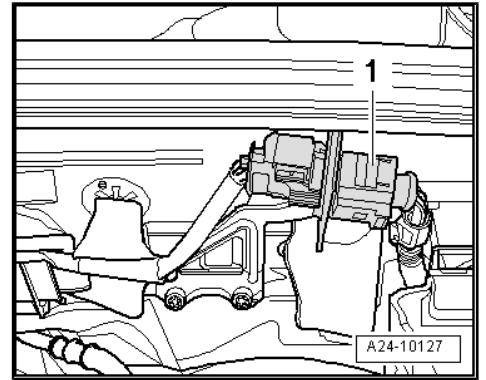

Lambda probe after catalytic converter

1 - Lambda probe, after catalytic converter -G130- and Lambda probe heater 1, after catalytic converter -Z29-

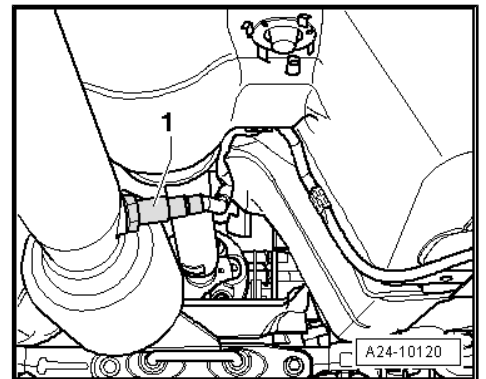

Electrical connector

Pfeil - Lambda probe, after catalytic converter -G130- and Lambda probe heater 1, after catalytic converter -Z29- on right-side underbody

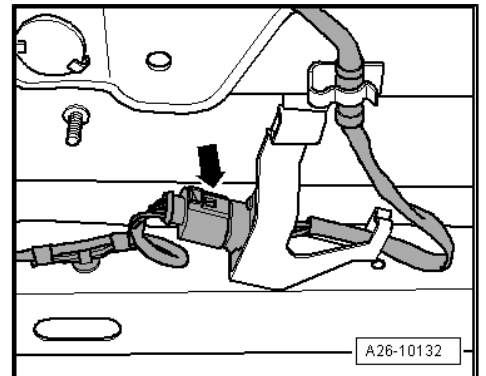

Radiator outlet coolant temperature sender -G83- -1-

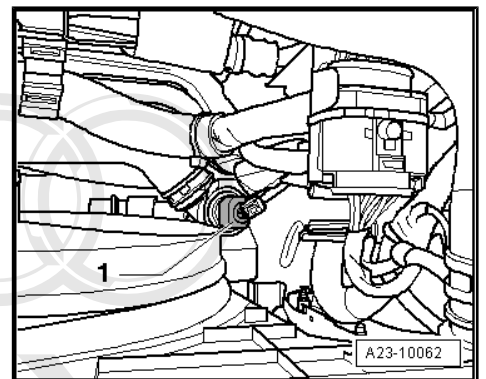

Protected by copyright. Copying for private or commercial purposes, in part or in whole, is not permitted unless authorised by AUDI AG. AUDI AG does not guarantee or accept any liability with respect to the correctness of information in this document. Copyright by AUDI AG.



Connector

4 - Clutch position sender -G476-

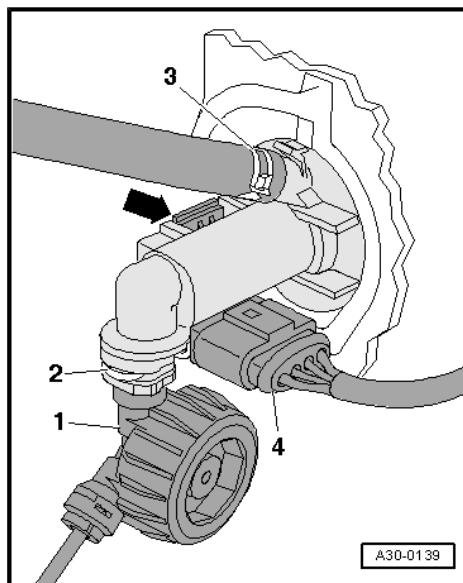

Pedal bracket

Pfeil - Brake light switch -F- and brake pedal switch -F63-

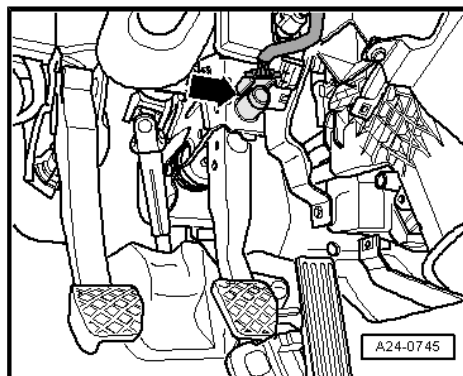

Fitting location of accelerator pedal position sender -G79- and accelerator pedal position sender 2 -G185- (in driver's footwell)

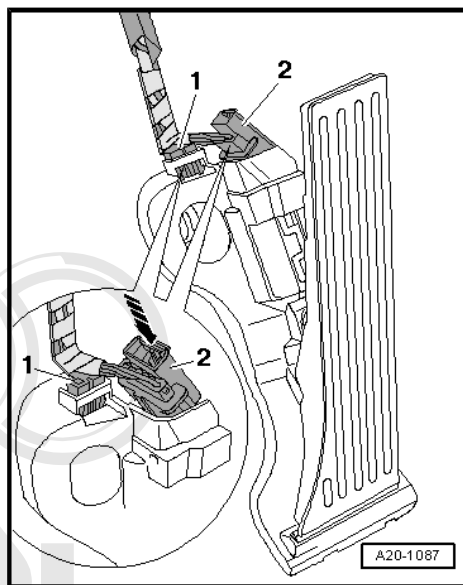

Protected by copyright. Copying for private or commercial purposes, in part or in whole, is not permitted unless authorised by AUDI AG. AUDI AG does not guarantee or accept any liability with respect to the correctness of information in this document. Copyright by AUDI AG.

Relay and fuse carrier in electronics box

- R1 - Terminal 15 voltage supply relay -J329-
- R2 - Voltage supply relay (terminal 50) -J682-
- R3 - Current supply relay for engine components -J757-
- R4 - Motronic current supply relay -J271-

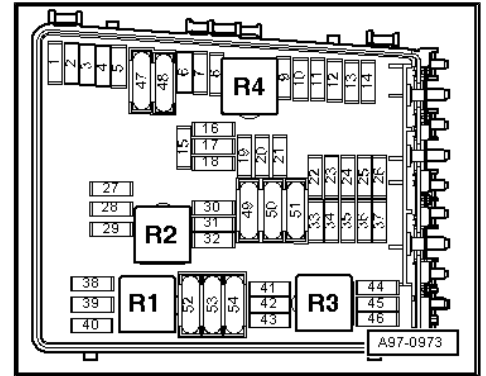
**Electrical connectors**

- 1 - 3-pin connector (green) for knock sensor 1 -G61-
- 2 - 3-pin connector (brown) for knock sensor 2 -G66-
- 3 - Oil pressure sender -G10-
- 4 - Engine speed sender -G28-
- 5 - 3-pin electrical connector (grey) for engine speed sender -G28-

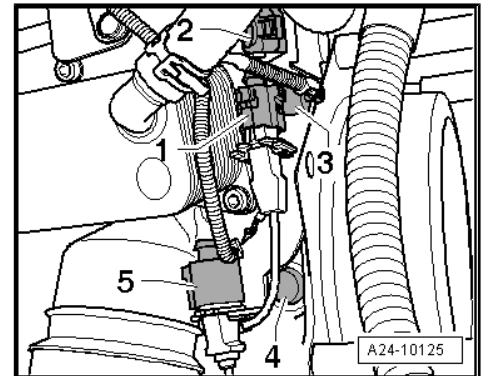
**Fitting locations of components below intake manifold**

- 1 - Knock sensor 1 -G61-
- 2 - Knock sensor 2 -G66-
- 3 - Oil pressure sender -G10-
- 4 - 3-pin connector (brown) for knock sensor 2 -G66-
- 5 - 3-pin electrical connector (grey) for engine speed sender -G28-
- 6 - Electrical connector for Hall sender -G40- and fuel pressure sender -G247-
- 7 - 8-pin connector for injectors

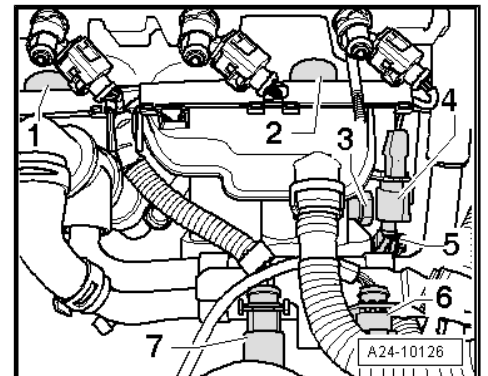
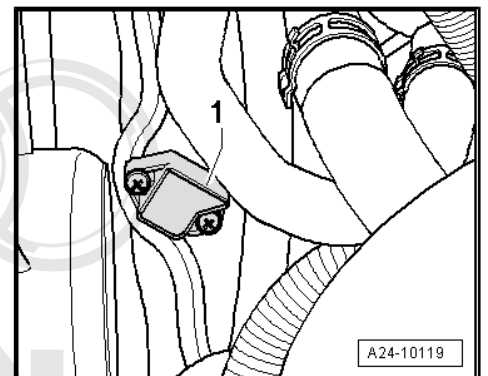
**Charge air pressure sender -G31- -1-**



Components on turbocharger

- 1 - Removing and installing turbocharger: → Rep. Gr. 21
- 2 - Tighten charge pressure control solenoid valve -N75- to 3 Nm
- 3 - Tighten turbocharger air recirculation valve -N249- to 7 Nm (note installation position, refer to next illustration)

Protected by copyright. Copying for private or commercial purposes, in part or in whole, is not permitted unless authorised by AUDI AG. AUDI AG does not guarantee or accept any liability with respect to the correctness of information in this document. Copyright by AUDI AG.

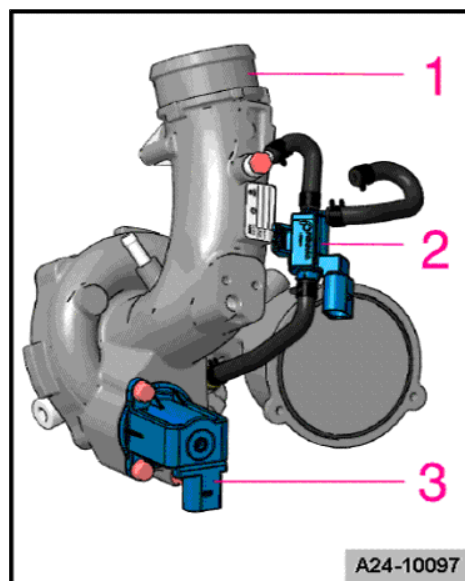

Pay attention to installation position of turbocharger air recirculation valve -N249-

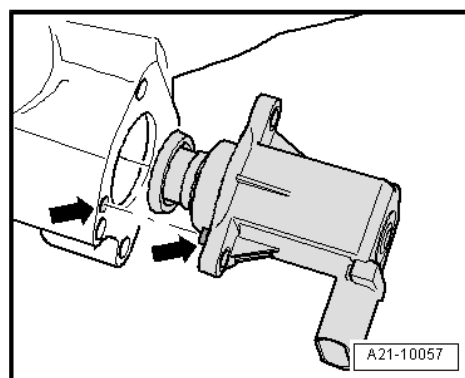

1.7 Exploded view - intake manifold

1 - Screw for intake air temperature sender 2 -G299-

- 5 Nm

2 - Intake air temperature sender 2 -G299-

3 - Intake manifold

- Removing and installing → [Chapter \(page 18\)](#)

4 - Solenoid valve 1 for activated charcoal filter -N80-

5 - Bolt for single-plunger high-pressure pump

- 3 x
- 10 Nm

6 - Fuel pressure regulating valve -N276-

7 - Mechanical single-plunger high-pressure pump

- With fuel pressure regulating valve -N276- and fuel pressure sender, low pressure -G410-
- An electric fuel pump (fitted in fuel tank) supplies fuel to the mechanical high-pressure pump at a pressure of approx. 6 bar.
- When installing the high-pressure fuel pump, it is essential to ensure that no dirt enters the fuel system.

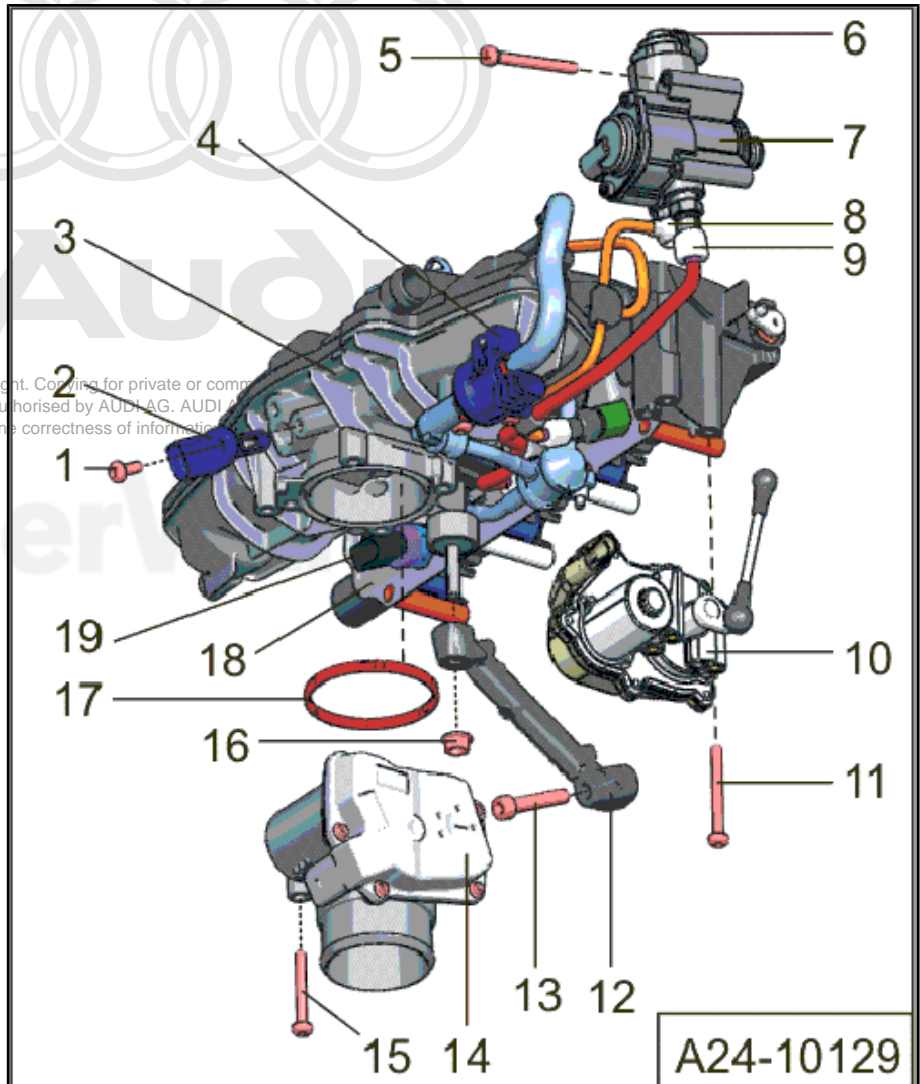

- The fuel system must not be under pressure; procedure for reducing fuel pressure → [Chapter \(page 3\)](#)
- Fuel pipes must be free of tension when installed.
- Removing and installing → [Chapter \(page 32\)](#)

8 - Connection for fuel return pipe to fuel tank

- Renew bolt for fuel return pipe.
- Tighten connecting piece to 40 Nm (always make sure that connecting piece is tightened to specified torque before installing fuel line)
- Fuel line must be free of tension when installed (make sure all parts are clean); tightening torque: 25 Nm

9 - Fuel supply line to fuel rail

- Tighten connecting piece to 30 Nm (always make sure that connecting piece is tightened to specified torque before installing fuel line)
- Fuel line must be free of tension when installed (make sure all parts are clean); tightening torque: 30 Nm

10 - Intake manifold flap motor -V157- with intake manifold flap potentiometer -G336-

- After the fuel rail has been renewed, intake manifold flap potentiometer -G336- must be re-adapted to the engine control unit → Vehicle diagnosis, testing and information system VAS 5051; "Guided Function"

11 - Bolt for intake manifold flap motor -V157- with intake manifold flap potentiometer -G336-

- 3 x



- 7 Nm

12 - Intake manifold support

13 - Bolt for intake manifold support

- 23 Nm

14 - Throttle valve module -J338- , throttle valve drive for electric throttle operation -G186-

- Angle sender 1 for throttle valve drive (electric throttle operation) -G187- and angle sender 2 for throttle valve drive (electric throttle operation) -G188-
- After the throttle valve module -J338- has been renewed, it must be re-adapted to the Motronic control unit -J220- (Basic setting, Display group 60), see → Vehicle diagnosis, testing and information system VAS 5051; "Guided Function"

15 - Bolt for throttle valve module -J338-

- 4 x
- 7 Nm

16 - Securing nut for intake manifold support

- 10 Nm

17 - Seal

- Renew

18 - Fuel rail

- Removing and installing → [Chapter \(page 20\)](#)

19 - Fuel pressure sender -G247-

- 20 Nm



Audi

Protected by copyright. Copying for private or commercial purposes, in part or in whole, is not permitted unless authorised by AUDI AG. AUDI AG does not guarantee or accept any liability with respect to the correctness of information in this document. Copyright by AUDI AG.



1.8 Exploded view - fuel rail

1 - Radial compensation element

- Renew if damaged

2 - Injector

- With combustion chamber ring seal (teflon ring seal): always renew
- Renew O-rings
- Ensure correct installation position.
- Removing and installing
→ [Chapter \(page 23\)](#)

3 - Support ring

4 - Fuel rail

- Removing and installing
→ [Chapter \(page 20\)](#)

5 - Fuel pressure sender - G247-

- Tightening torque: 22 Nm
- Tighten connecting piece to 30 Nm

6 - Fuel pressure sender for low-pressure section -G410-

7 - Fuel pressure regulating valve -N276-

8 - Mechanical single-plunger high-pressure pump

- With fuel pressure regulating valve -N276- and fuel pressure sender, low pressure -G410-

- An electric fuel pump (fitted in fuel tank) supplies fuel to the mechanical high-pressure pump at a pressure of approx. 6 bar.

- When installing the high-pressure fuel pump, it is essential to ensure that no dirt enters the fuel system.

- The fuel system must not be under pressure when installing the high-pressure pump; procedure for reducing fuel pressure → [Chapter \(page 3\)](#)

- Fuel pipes must be free of tension when installed.

- Removing and installing → [Chapter \(page 32\)](#)

9 - Solenoid valve 1 for activated charcoal filter -N80-

10 - Throttle valve module -J338- , throttle valve drive for electric throttle operation -G186-

- Angle sender 1 for throttle valve drive (electric throttle operation) -G187- and angle sender 2 for throttle valve drive (electric throttle operation) -G188-

- After the throttle valve module -J338- has been renewed, it must be re-adapted to the Motronic control unit -J220- (Basic setting, Display group 60), see → Vehicle diagnosis, testing and information system VAS 5051; "Guided Function"

11 - Intake air temperature sender 2 -G299-

- Tightening torque: 5 Nm

12 - Bolts for intake manifold

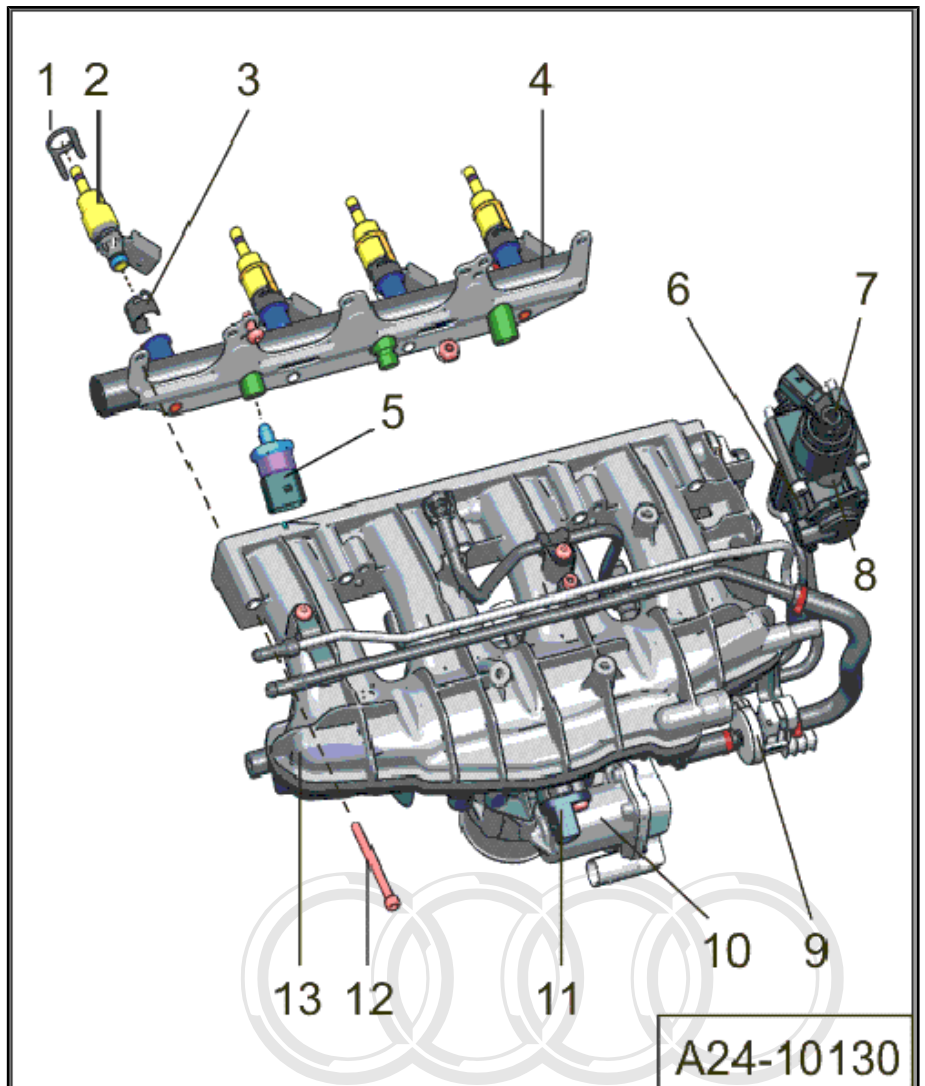

A24-10130