

**Workshop Manual**

**Audi 80 1992 ▶**

***Booklet* Electrical system**

**Edition 07.96**





	Removing and installing Nippon Seiki coolant temperature gauge .....	90-69
	- Removing and installing Nippon Seiki digital clock .....	90-70
	Removing and installing brightness control for dash panel insert lighting, switches and instruments .....	90-71
	Removing and installing periscope lamps .....	90-71
	- Removing and installing display unit for mini-check system .....	90-72
	- Removing and installing display unit for auto-check system/on-board computer .....	90-72
	- Removing and installing voltage stabiliser .....	90-73
	- Removing and installing gear indicator .....	90-73
	- 5-pin connector behind dash panel insert for gear indicator .....	90-74
	- Removing and installing outside temperature gauge .....	90-76
	- 5-pin connector behind dash panel insert for outside temperature gauge .....	90-77
	- Checking outside temperature gauge .....	90-79
	Removing and installing outside temperature gauge sensor .....	90-80
	<b>Additional instruments</b> .....	<b>90-81</b>
	Servicing additional instruments ▶ 01.92 .....	90-81
	- Servicing additional instruments 02.92 ▶ .....	90-85
	- Removing and installing components of additional instruments 02.92 ▶ .....	90-89
	- Checking oil pressure gauge .....	90-92
	- Checking oil temperature gauge .....	90-93
	- Checking voltmeter .....	90-94
<b>91</b>	<b>Radio, 2-way radio, Telephone</b> .....	<b>Page</b>
	<b>Car radio systems</b> .....	<b>91-1</b>
	Radio systems: general layout .....	91-3
	- Removing and installing the radio ▶ 06.94 .....	91-5
	Removing and installing radio 07.94 ▶ .....	91-6
	- Removing and installing amplifier ("gamma CD" radio only) .....	91-7
	<b>Structure of radio systems</b> .....	<b>91-8</b>
	- "Alpha" and "Beta" radio ▶ 06.94 .....	91-8
	"Gamma CC" radio ▶ 06.94 .....	91-10
	"Gamma CD" radio ▶ 06.94 .....	91-14
	- "Beta" radio 07.94 ▶ .....	91-19
	- "Gamma" radio 07.94 ▶ .....	91-21
	<b>Layout of loudspeaker systems</b> .....	<b>91-24</b>
	- Removing and installing front loudspeaker .....	91-26
	- Removing and installing rear loudspeaker .....	91-27
	<b>Layout of aerial systems</b> .....	<b>91-32</b>
	- Removing and installing fuc aerial .....	91-38
	- Removing and installing power aerial .....	91-40
	Avant roof aerial ▶ 06.94 .....	91-42
	- Roof aerial with amplifier, Avant 07.94 ▶ .....	91-44
<b>92</b>	<b>Windscreen wipe and wash system</b> .....	<b>Page</b>
	<b>Servicing windscreen washer system</b> .....	<b>92-1</b>
	<b>Servicing windscreen washer system and headlight washer system</b> .....	<b>92-7</b>
	- Removing and installing reservoir for windscreen and headlight washer system .....	92-16
	- Removing and installing jets for windscreen washer system .....	92-17
	<b>Servicing rear window wiper system</b> .....	<b>92-19</b>
	- Removing and installing rear window wiper arm .....	92-19
	- Removing and installing rear window wiper motor .....	92-20
	Removing, installing and adjusting jet for rear window washer system .....	92-22
<b>94</b>	<b>Lights, Lamps, Switches - exterior</b> .....	<b>Page</b>
	<b>Servicing headlights</b> .....	<b>94-1</b>
	Servicing headlights, 4- and 5-cylinder .....	94-2
	- Servicing dual headlights, 6-cylinder, S2 .....	94-9
	- Servicing electrical headlight range adjustment .....	94-16
	- Removing and installing control motor .....	94-19
	- Removing and installing dual headlight control motor .....	94-21
	<b>Servicing tail light</b> .....	<b>94-23</b>

	Removing and installing steering column switch.....	94-29
	- Servicing steering column switch.....	94-35
	Removing and installing ignition switch.....	94-43
	Removing and installing steering column lock switch with lock cylinder.....	94-45
<b>96</b>	<b>Lights, Lamps, Switches - interior</b>	<b>Page</b>
	<b>Servicing switches in centre console</b> .....	<b>96-1</b>
	- Removing and installing pushbutton switches.....	96-4
	- Replacing bulbs in pushbutton switches.....	96-6
	- Checking switch for electrically heated mirrors 07.92 ▶.....	96-7
	<b>Electric window lifters</b> .....	<b>96-9</b>
	- Front electric window lifter - exploded view.....	96-10
	- Rear electric window lifters - exploded view.....	96-15
	- Dismantling and assembling electric window lifters.....	96-22
	<b>Electrically adjustable seats</b> .....	<b>96-29</b>
	- Electrically adjustable seat - exploded view.....	96-30
	- Electrically adjustable backrest - exploded view.....	96-35
	- Removing and installing switch unit on seat.....	96-37
	- Removing and installing front/rear seat height adjustment motor.....	96-38
	- Removing and installing longitudinal adjustment motor.....	96-39
	- Removing and installing front/rear height adjuster.....	96-40
	- Removing and installing longitudinal adjuster.....	96-40
	- Removing and installing backrest adjustment motor.....	96-41
	- Functional test of electrically adjustable seats.....	96-42
	<b>Servicing cruise control system</b> .....	<b>96-43</b>
	- Testing vacuum system for cruise control.....	96-51
	<b>Servicing immobiliser</b> .....	<b>96-52</b>
	- Overview.....	96-52
	- Removing and installing immobiliser control unit.....	96-54
	- Replacing reader coil -D2.....	96-55
<b>97</b>	<b>Wiring</b>	<b>Page</b>
	<b>Relay plate</b> .....	<b>97-1</b>
	- Removing and installing relay plate with fuse box.....	97-1
	- Removing and installing auxiliary relay carrier with connector point.....	97-10

## Self-diagnosis

### Note:

*Synchronising keys in vehicles with infrared remote control*

→ General Body Repairs; Repair Group 57, Central locking system; Synchronising keys for infrared remote control →

### Immobiliser self-diagnosis

The electronic immobiliser is equipped with self-diagnosis capability. If faults occur in system components, fault codes are stored in the immobiliser control unit -J362 which can then be read out using the V.A.G 1551 or V.A.G 1552 fault reader.

The electronic immobiliser has the following self-diagnosis functions:

- ◆ Interrogate fault memory
- ◆ Erase fault memory
- ◆ Reading measured value block
- ◆ Adapt vehicle key
- ◆ Adapt immobiliser control unit on engine control unit replacement

01-1

### Connecting V.A.G 1551 fault reader

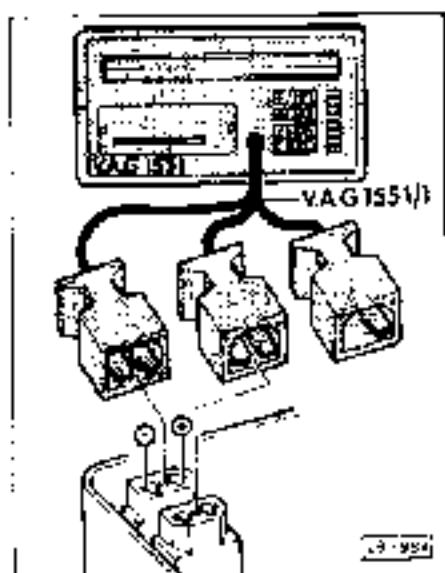

- Switch off ignition
- Connect V.A.G 1551/1 diagnosis cable to the diagnosis connectors at relay plate with fuse box in the plenum chamber as follows:
- Attach black connector of V.A.G 1551/1 diagnosis cable to black diagnosis connector and white connector to white diagnosis connector.

### Note:

*The V.A.G 1551/1 blue diagnosis connector is not required.*

Switch ignition on.

Reading on display.

! Displayed alternately

### Notes:

- ◆ Additional operating instructions can be obtained by pressing the V.A.G 1551 HELP key.
- ◆ The → key switches to the next step in the program sequence

01-2

## Starting immobiliser self-diagnosis

- Press key 1 for mode 1. "Rapid data transfer".

Rapid data transfer	HELP
Enter address word XX	

Reading on display:

Press keys 2 and 5 for "Immobiliser" address word.

Rapid data transfer	0
25 - Immobiliser	

Reading on display:

Confirm entry with 0 key.

Rapid data transfer	
Tester transmits address word 25	

Heading on display:

- Wait approx. 5 seconds.

4A0953234	MWD	AUZxxxxxxx	D66
Coating	00000	W5C0E3B0	

Reading on display:

4A0953234: Number of control unit

- IMMO: System designation

AUZ9Z0H2000323: 14 position ident. no.

- D66: Software version

- Press → key to continue

Rapid data transfer	HELP
Select function XX	

Reading on display:

01-3

## Interrogate fault memory

Press keys 0 and 2 for "Interrogate fault memory" function

Rapid data transfer	0
02 - Interrogate fault memory	

Reading on display:

- Confirm entry with 0 key.

No fault detected	
-------------------	--

Heading on display:

- Press → key.

or

X faults detected	
-------------------	--

Reading on display:

If the printer is switched on, the stored faults will be displayed and printed out in sequence

**Note:**

*If the printer is off, press → key to display the next fault.*

- Press → after the last fault has been displayed and printed.

Rapid data transfer	HELP
Select function XX	

Reading on display:

- Rectify printed faults according to fault table -> Page 318, then erase fault memory and interrogate it again as a check.

01-4

## Erase fault memory

### Prerequisite:

- Fault memory interrogated –> Page 01-4.

Rapid data transfer	HELP
Select function XX	

- ◀ Reading on display:
  - Press keys 0 and 5 for "Interrogate fault memory"

Rapid data transfer	0
05 - Erase fault memory	

- ◀ Reading on display:
  - Confirm entry with 0 key.

Rapid data transfer	HELP
Select function XX	

- ◀ Reading on display.

## Reading measured value block

Rapid data transfer	HELP
Select function XX	

- ◀ Reading on display:
  - Press buttons 0 and 8 to read "Measured value block".

Rapid data transfer	0
08 - Reading measured value block	

- ◀ Reading on display:
  - Confirm entry with 0 key.

Read measured value block	HELP
Enter display group number XX	

- ◀ Reading on display:
  - Press buttons 0 and 1 for Display Group number 01 and confirm using the 0 button.

The measured value block which has been selected will appear in standard format Evaluation => Page 01-7

Read measured value block	1→
1	1

- ◀ Example of display:
  - Press → key to continue.

Rapid data transfer	HELP
Select function XX	

- ◀ Reading on display.



Read measured value block	1 →
1	1

Evaluate measured value block  
Display Group 01

Display/test value	Designation
1 1;	1 - Engine may be started
1 1;	2 - Engine control unit reply
1 1;	3 - Key OK

1 Example of display

- ◆ Display/test value 0 = no
- ◆ Display/test value 1 = yes

**Fault evaluation:**

- ◆ Engine may not be started:  
Key used is not been coded or has been incorrectly coded
- ◆ No response from engine control unit:  
Fault in engine control unit or wiring
- ◆ Key status OK not  
Key used is defective.

## Immobiliser fault table

**Notes:**

- ◆ All static and sporadic faults are stored in the fault memory.
- ◆ A fault is recognised as being static if it is present for at least 2 seconds. If the fault does not occur again it is registered as a sporadic fault. "SP" appears on right of display.
- ◆ When the ignition is switched on, all existing faults are set to sporadic and will only be stored as static faults if they still exist after checking.
- ◆ Sporadic faults which have not occurred again for 50 driving cycles (ignition on for at least 2 minutes) are erased.

V.A.G 1551 print-out	Possible causes of fault	Possible effect	Fault remedy
00750 Fault lamp	◆ Wiring damaged.	● Warning lamp flashes	- Eliminate wiring damage
Short to earth/open circuit	◆ Open circuit ◆ Warning lamp -K117 defective	● Warning lamp does not blink ● Warning lamp does not blink	- Rectify open circuit. Replace warning lamp -> Page 90 11.
Short circuit to positive	◆ Wiring damaged.	● Warning lamp does not blink	- Eliminate wiring damage
01178 Immobiliser reader coil	◆ Immobiliser reader coil -D2 defective ◆ Open circuit	● Engine will not start and warning lamp is on	Replace reader coil -> Page 95 55. Rectify open circuit.

V.A.G 1551 print-out	Possible causes of fault	Possible effect	Fault remedy
01176 Key	◆ Transponder defective	● Engine will not start and warning lamp is on	- Make new key
Signal too small	◆ Wrong key		- Perform vehicle key adaptation
Not authorised	◆ Immobiliser reader coil -D2 defective		- Replace reader coil => Page 94 15.
01177 Engine control unit not authorised	◆ Replace engine control unit	● Engine will not start and warning lamp is on	- Perform adaptation during engine control unit replacement
01179 Incorrect key programming	◆ Incorrect key adaptation	● Warning lamp flashes	- Read out fault memory Clear fault memory. Perform vehicle key adaptation
65535 Control unit faulty	◆ Immobiliser control unit -J362 defective	● Engine will not start and warning lamp is on	Replace immobiliser control unit -J362 -> Page 96 01

## Performing vehicle key adaptation

### Prerequisites:

- All vehicle keys available.
- Key ring with code number available, otherwise code number has to be established -> Page 01 10
- Connect fault reader V.A.G 1551 -> Page 01 2
- Switch ignition on.
- Starting immobiliser self-diagnosis -> Page 01 3.

Rapid data transfer	HELP
Select function XX	

- ◀ Reading on display.
- Press key 1 twice for "Login procedure" function.

Rapid data transfer	Q
11 - Log ^ procedure	

- ◀ Heading on display
- Confirm entry with Q key.

01-11

Login procedure	Q
Enter code number XXXXX	

- ◀ Reading on display:
- Enter code number.

### Notes:

- ◆ When entering code number, precede the 4-digit number with a 0.
- ◆ The code number is marked beneath a rubber coating on the key ring issued to the customer when the vehicle was handed over. The rubber coating can be removed by rubbing.
- ◆ If the code number is incorrectly entered twice, the control unit is disabled for 30 minutes. The ignition must be set to "On" for 30 minutes before the next attempt.
- Confirm entry with Q key.

Rapid data transfer	HELP
Select function XX	

- ◀ Reading on display:
- Press 1 and Q for "Adaptation" function.
- Confirm entry with Q key.

Adaptation	Q
Enter channel number XX	

- ◀ Reading on display:
- Press Q and 1 for channel 1.
- Confirm entry with Q key.

01 12

Channel 1	Adaptation	2 →
-----------	------------	-----

- ◀ Reading on display:
  - Press → key to continue

Channel 1	Adaptation	2 →
Enter adaptation value XXXX		

- ◀ Reading on display:
  - Press key 0 four times and enter number of keys to be adapted (0 to 8 keys).

*Note:*  
Entering "0 keys" results in electronic locking of the vehicle.

  - Confirm entry with 0 key.

Channel 1	Adaptation	3 0
-----------	------------	-----

- ◀ Reading on display:
  - Confirm entry with 0 key.or

Channel 1	Adaptation	2 →
-----------	------------	-----

- ◀ Reading on display:
  - Press key 1 to decrease number of keys, or key 2 to increase, e.g. to 3

Channel 1	Adaptation	3 0
-----------	------------	-----

- ◀ Reading on display:
  - Confirm entry with 0 key.

— 01-13 —

Channel 1	Adaptation	3 0
Store changed value?		

- ◀ Reading on display:
  - Confirm entry with 0 key.

Channel 1	Adaptation	3 →
Changed value < stored		

- ◀ Reading on display:
  - Key in ignition lock has now been adapted
  - The ignition must be switched on using all the other keys for this vehicle until the warning lamp goes off

*Note:*

*Adaptation is complete, when*

- ◆ The number of keys to be adapted has been reached.
  - ◆ A key that has already been adapted is adapted again.
  - ◆ The total adaptation time of 30 seconds has been exceeded
- Finish adaptation on the V.A.G 1551 by pressing the → key and return to function mode.

Rapid data transfer	HELP
Select function XX	

- ◀ Reading on display:

— 01-14 —

## Adaptation during engine control unit replacement

### Prerequisite:

- Authorised vehicle key available
- Connect fault reader V.A.G 1551 -> Page 01 1.
- Switch ignition on.
- Starting immobiliser self diagnosis -> Page 01 3

Rapid data transfer	HHIP	◀
Select function XX		

- Reading on display:
- Press 1 and 0 for "Adaptation" function.
  - Confirm entry with 0 key.

Adaptation	0	◀
Enter channel number XX		

- Reading on display:
- Press key 0 twice.
  - Confirm entry with 0 key.

01-15

Adaptation	0	◀
Press learned values?		

- Reading on display:
- Confirm entry with 0 key.

Adaptation	▶	◀
Learned values have been erased		

- Reading on display:
- Press → key to continue

Rapid data transfer	HHIP	◀
Select function XX		

- Reading on display:

### Note:

*The next time the ignition is switched on, the engine control unit identifier is read into the immobiliser control unit.*

01 16

## Testing system

- Not for vehicles with engine code letters NG-engine (KF II 2.3 l)

### Prerequisite

- The ignition must have been switched off for at least 30 seconds.
- Cover receiving coil with a slotted metal plate, e.g. place shim between ignition lock and ignition key, or detach reader coil electrical cable at ignition/starter switch.
- Attempt to start vehicle – the engine should not run and warning lamp should flash.
- Connect fault reader V.A.G 1551 –> Page 01-2.
- Starting immobiliser self diagnosis –> Page 01-3
- Interrogate fault memory –> Page 01-4. Error message: "Key signal too low" or "Immobiliser reader coil".
- Erasing fault memory –> Page 01-5.

01-17

- Only for vehicles with engine code letters NG engine (KC III 2.3 l)

- Connect fault reader V.A.G 1551 –> Page 01-2
- Starting immobiliser self diagnosis –> Page 01-3
- Select final control element diagnosis function (05).
- Attempt to start three times in succession, engine should not start:

1. Path	Pin 5 (2V (NC relay)
2. Path	Pin 4, high impedance (NO relay)
3. Path	Open circuit in starting relay

The fault lamp blinks Fault lamp goes off after 3rd path

- Erase fault memory in FEI control unit
- > KE III Jetronic ignition system (5-cylinder): Repair group 01: Self-diagnosis with fault reader V.A.G 1551, Fault memory interrogation with V.A.G 1551 =>

01-18

### **Lost key procedure**

- Make replacement key using locking mechanism number.
- Perform key adaptation. -> Page 01-11.

### **Establishing code number**

- Connect fault reader V.A.G 1551 -> Page 01-2.
- Starting immobiliser self diagnosis -> Page 01-3
- 14Read out 14-position immobiliser control unit ident. no.
- Using the ident. no., obtain the code number via the appropriate Sales Centre or Importer using the dealer on-line system (HDS).

## Checking and charging battery

### Warning

Always disconnect battery earth strap before working on electrical system.

### Checking electrolyte level

- ◆ Only top up with distilled water if electrolyte level is below "min" mark.
- ◆ Highly charged batteries with excessive electrolyte level (long journeys using few consumers) may "boil over". Having too little electrolyte may reduce the service life of the battery.

27-1

### Measuring voltage under load

- ◆ The voltage can be measured under load using a battery tester such as the V.A.G 1498.
- ◆ The load current and minimum voltage differ depending on the battery capacity and should be taken from the label on the tester or the following table.

Capacity	Cold test current	Load current	Minimum voltage
36 Ah	175 A	100 A	10.0 V
40 Ah	220 A	200 A	9.4 V
50 Ah	265 A	200 A	9.6 V
63 Ah	300 A	200 A	9.5 V
88 Ah	395 A	300 A	9.5 V
92 Ah	450 A	300 A	9.5 V

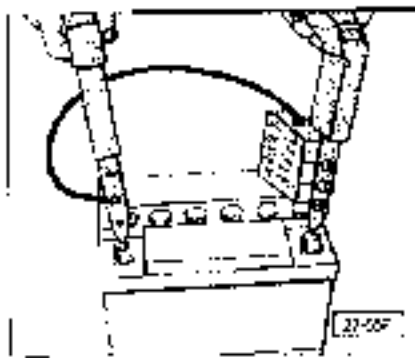

27-2



- ◆ If the minimum voltage is not attained for a loading period of 5 to 10 seconds, the battery is flat or defective. Check specific gravity of acid.

**Note:**

*To avoid the risk of explosion, never test a battery that is gas-sing.*

- ◆ Batteries with a capacity of more than 63 Ah are not to be checked using the VW 1256 battery tester and charger, since this testing facility is only designed for batteries up to max. 63 Ah.
- ◆ The battery tester V.A.G. 1498 is suitable for batteries with capacities between 30 and 200 Ah.

**Checking specific gravity of acid.**

- ◆ In conjunction with the voltage measurement (under load), the specific gravity of the acid provides accurate information concerning the state of charge of a battery. Testing is performed using a hydrometer.

- ◆ The greater the specific gravity of the extracted electrolyte the higher the float rides. The density can be read off the scale as specific gravity or degrees Baumé.

The following values must be attained:

<b>Charge condition in normal climatic zones</b>	<b>o Bè</b>	<b>Spec. gravity</b>
Discharged	16	1.12
Semi-charged	24	1.20
Well charged	32	1.28
<b>Charge level in tropical countries</b>	<b>o Bè</b>	<b>Spec. gravity</b>
Discharged	11	1.08
Semi-charged	18	1.14
Well charged	27	1.23

## Notes on handling batteries

Batteries that have not been used for lengthy periods (e.g. vehicles in storage) are subject to self-discharge and may also be sulphated. If fast charging is performed on these batteries using standard charging units they do not accept charge current, or are shown as being "fully charged" before they actually are due to so-called surface charging. They appear to be defective.

Before these batteries are considered to be defective, perform the following checks.

- ◆ If the specific gravity of the acid in all the cells does not differ by more than 0.02 kg/dm<sup>3</sup> (e.g. 1.13 to 1.11), the battery should be charged. When charging is complete the battery should be subjected to a load test. The battery is only defective if the test values are not complied with.
- ◆ If the specific gravity of the acid in one or two adjacent cells is appreciably lower (e.g. five cells indicate 1.16 and one cell indicates 1.08), the battery has a short circuit and is defective.

## Charging battery

### Notes:

- ◆ Frozen batteries must be thawed out before charging.
- ◆ Do not enter rooms in which batteries are being charged with a naked flame or whilst smoking.
- ◆ Precision tools should also be kept away from such areas.

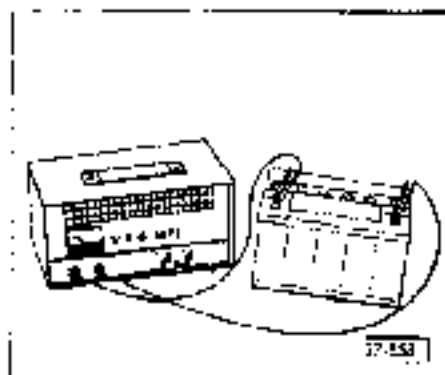

- ◆ The V.A.G 1471 battery charger can be used for normal charging of up to four 12 V batteries as well as batteries with different capacities (Ah = ampere-hour) and rated voltage.
  - Disconnect battery earth strap and then positive cable from battery.
  - Connect battery to charging unit, positive to positive, negative to negative.
  - Switch on charging current. The charging current depends on the capacity of the battery. The current should be about 10% of the battery capacity. In other words, the charge current should be about 4 A for a 40 Ah battery.

### **Quick charging/starting boost**

Fast charging can be carried out using the battery tester and charger VW 1266, whereas additional starting assistance can be provided by the V.A.G. 1572 battery starting charger.

## Dash panel insert

Removing and installing dash panel insert = > Page 90-8.

Removal and installation of dash panel insert components:

◆ Model without Auto-check system (in-board computer) = > Page 90-41.

◆ Model with Auto-check system (in-board computer) = > Page 90-35.

Emergency flasher relay installation position = > Fig. 1, Page 90-1.

Assignment of lamps in dash panel insert = > Page 90-9.

### Note:

Use the V.A.G 1526 manual multimeter, the V.A.G 1301 tester, the V.A.G 1598 test box and the V.A.G measuring tool kit for testing.

90-1

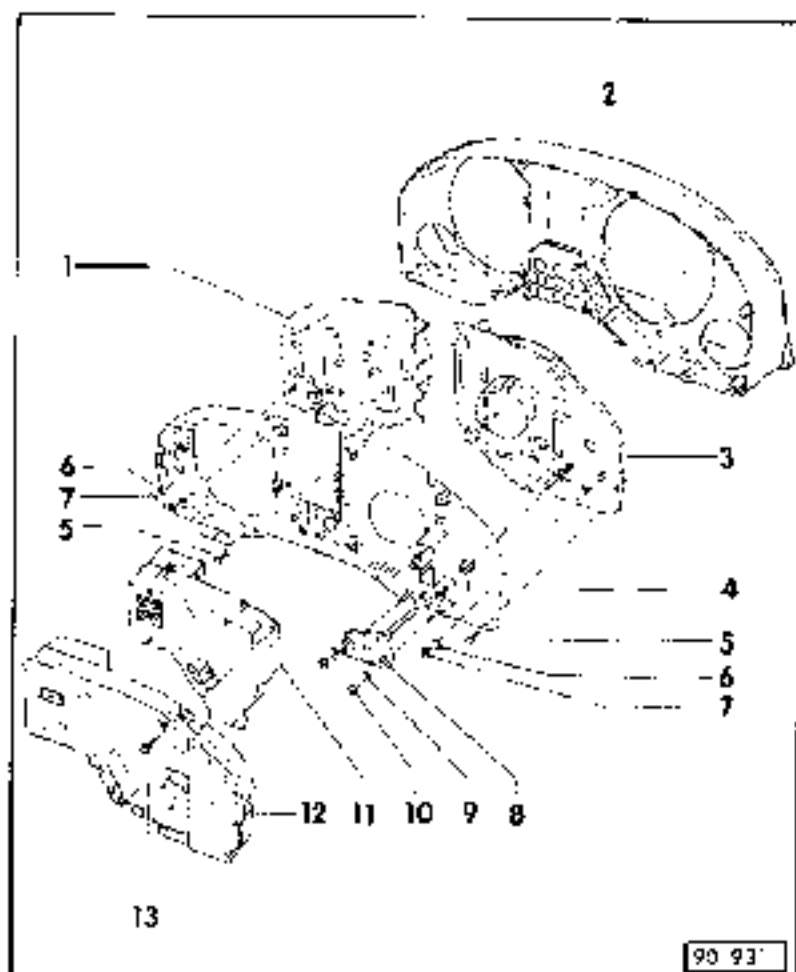

### VDO dash panel insert - exploded view

- 1 - **Base plate with speedometer**
  - ◆ Checking speedometer sensor = > Page 90-37.
  - ◆ Removing and installing = > Page 90-30.
- 2 - **Front frame with glass**
  - ◆ Removing and installing = > Page 90-31.
  - ◆ Set down carefully onto soft cloth to avoid scratching glass.
- 3 - **Base plate with rev counter**
  - ◆ Checking engine speed signal = > Page 90-40.
  - ◆ Removing and installing = > Page 90-31.

90-2

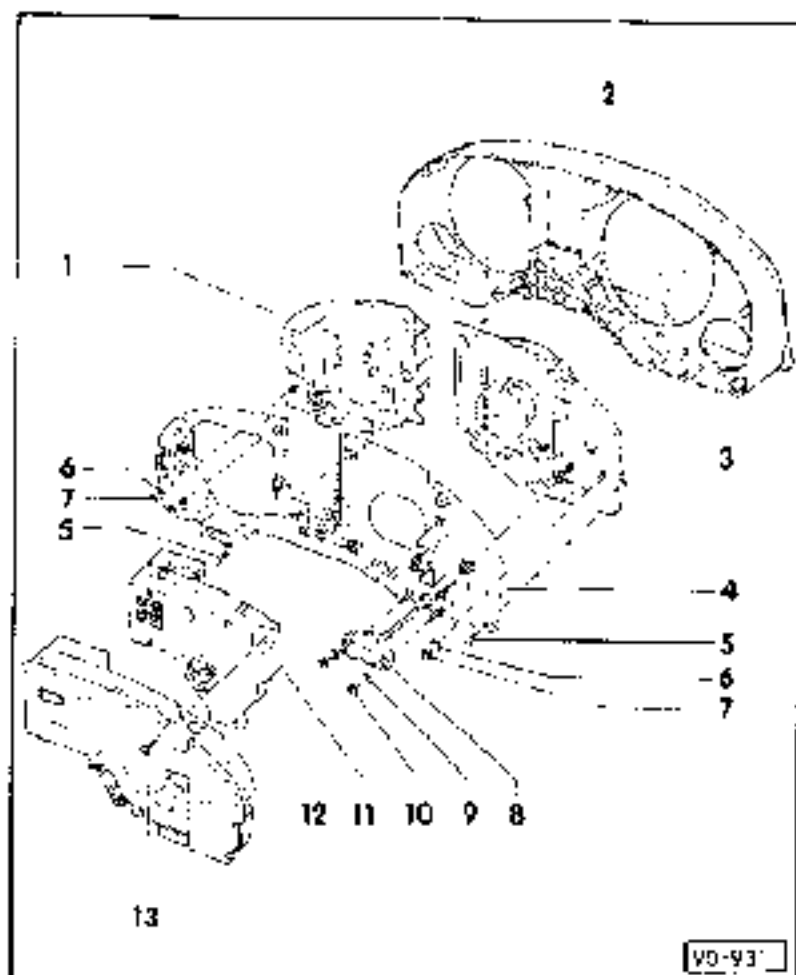

- 4 - Printed circuit board
  - ◆ Assignment of multi-pin connectors - > Page 90-13 on wards
  - ◆ Removing and installing - > Page 90-19
- 5 - Securing bolts
  - ◆ For printed circuit board
- 6 - Washer
- 7 - Hexagon nut
- B - Controller
  - ◆ For dash panel insert, switch and instrument lighting
  - ◆ Removing and installing - > Page 90-71

90-3

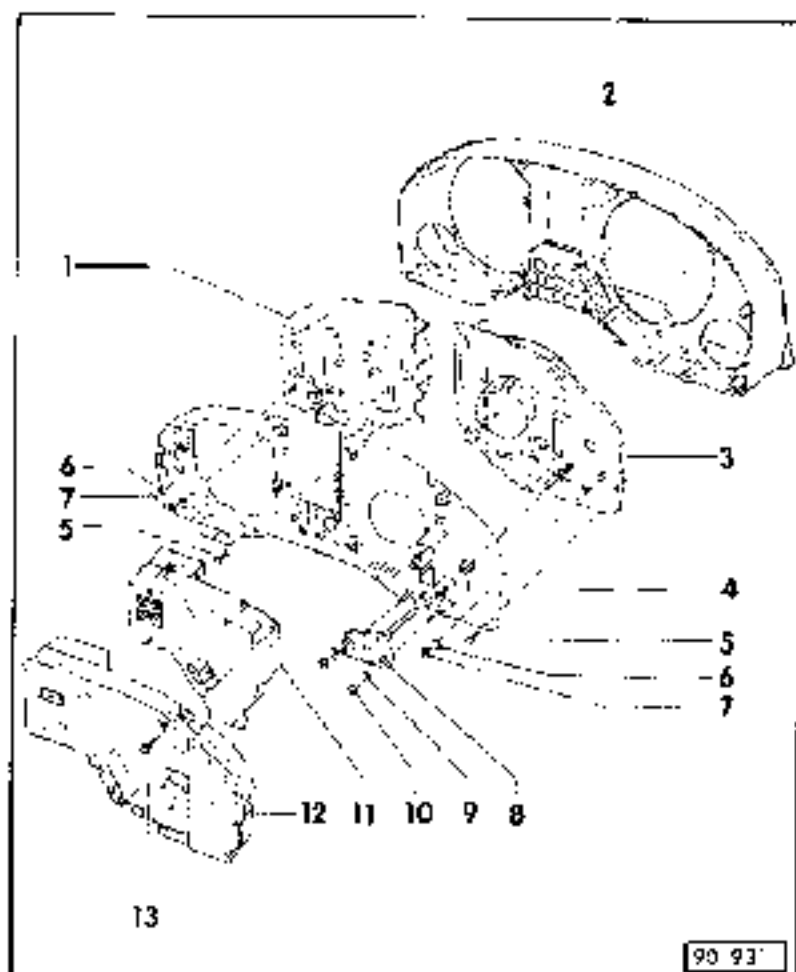

- 9 - Washer
- 10 - Hexagon nut
- 11 - Display unit
  - ◆ For mini-check system
  - ◆ Removing and installing - > Page 90-72
- 12 - Display unit
  - ◆ for auto-check system/on-board computer
  - ◆ Removing and installing - > Page 90-73
- 13 - Securing bolts
  - ◆ for mini-check/auto-check system/on-board computer

90-4

## Nippon Seiki dash panel insert - exploded view

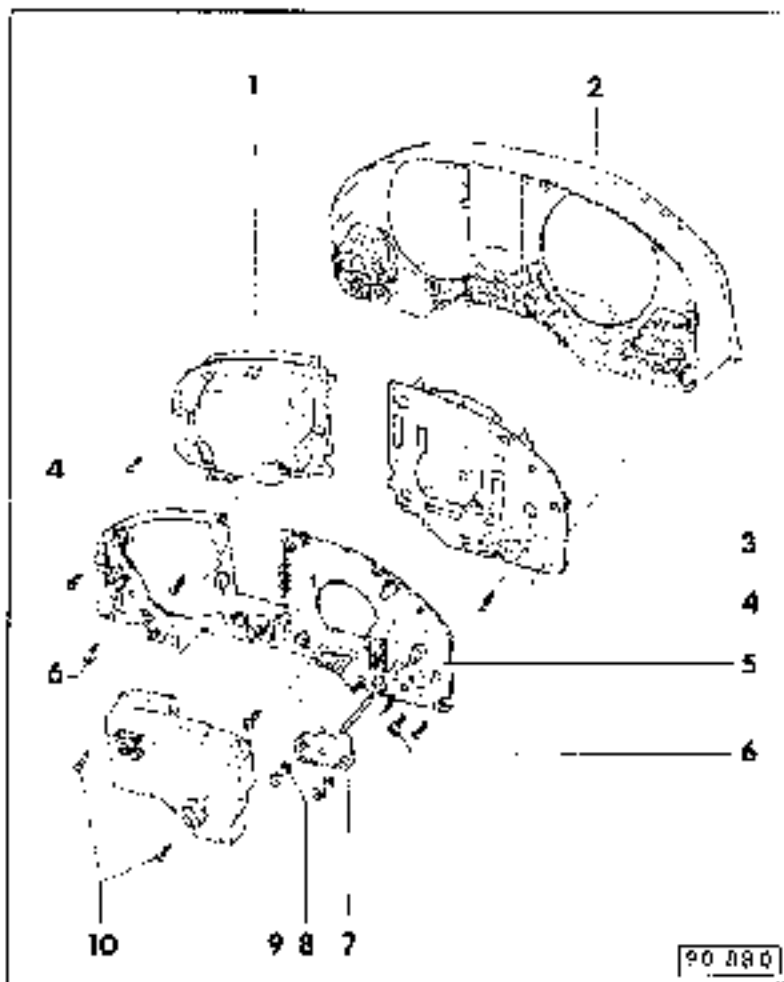

- 1 **Base plate with speedometer**
  - ◆ Removing and installing - > Page 90-55
- 2 **Front frame with glass**
  - ◆ Removing and installing - > Page 90-54
  - ◆ Set down carefully onto woolen cloth to avoid scratching glass
- 3 **Base plate with rev counter**
  - ◆ Removing and installing - > Page 90-57
- 4 **Securing bolts**
  - ◆ For base plates

90-5

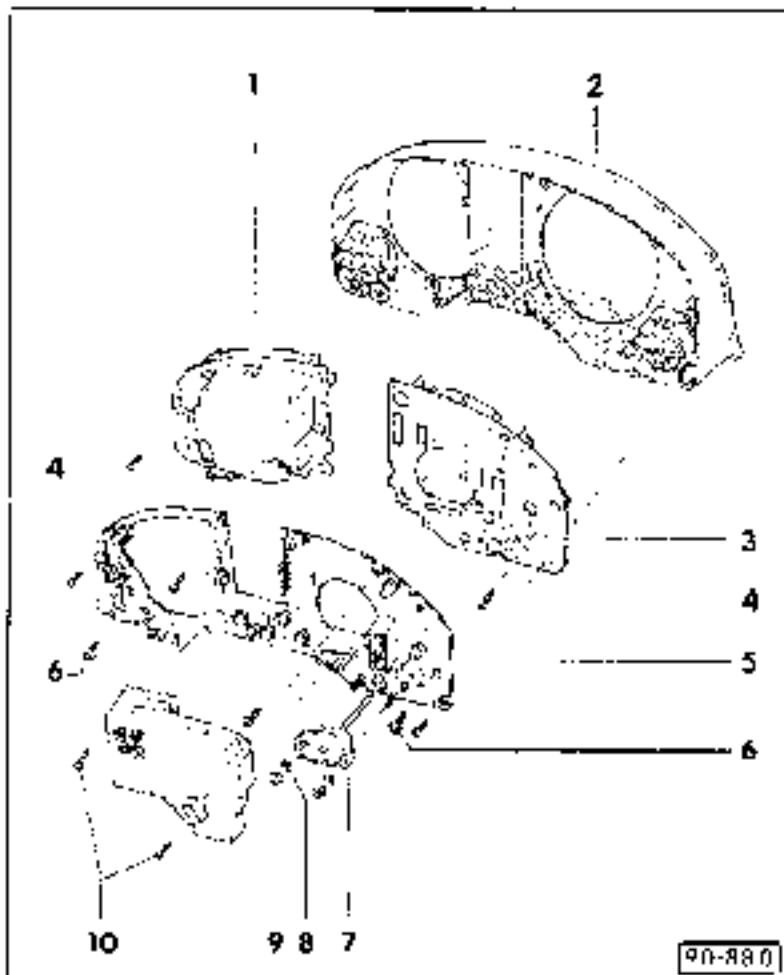

- 5 **Printed circuit board**
  - ◆ Assignment of multi-pin connectors - > Page 90-13 onwards
  - ◆ Removing and installing - > Page 90-13
- 6 **Securing bolt**
- 7 **Controller**
  - ◆ For dash panel insert, switch and instrument lighting
  - ◆ Removing and installing - > Page 90-71
- 8 **Washer**
- 9 **Hexagon nut**
- 10 **Securing bolts**
  - ◆ For printed circuit board

90-6

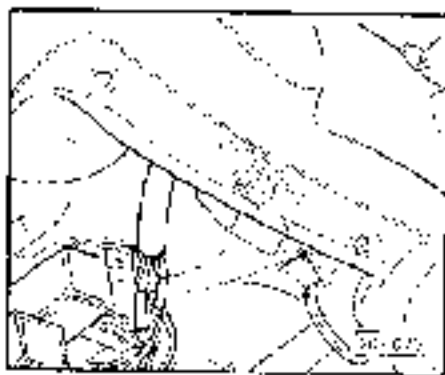

- 4 **Fig.1 Signal indicator/hazard warning relay installation position**  
 The emergency flasher relay is clipped to the bottom of the instrument panel.
- Removal and installation involves taking out the driver's-side tray
  - > General Body Repairs; Repair Group 70: Instrument Panel, Removing driver's side tray - >

### Removing and installing dash panel insert

Removing steering wheel and steering column switch -> Page 94-28.

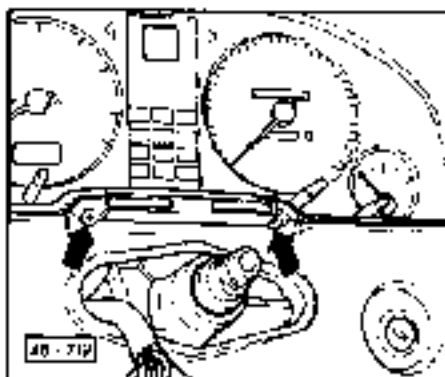

- 4
- Unscrew recessed-head screws-arrows-
  - Carefully pull dash panel insert out of instrument panel, placing a soft cloth over the steering column if necessary.
  - Removing plug for multi-pin connectors -> Page 90-18
  - Derach all connectors
  - Remove dash panel insert.

## Assignment of lamps in dash panel insert

- Removing and installing cap-type lamps -> Page 1077.

- 1 - Dash panel insert illumination
  - ◆ 1.2 W (fix)
- 2 - Right turn signal warning lamp
  - ◆ 1.2 W
- 3 - Unallocated
- 4 - Brake warning lamp
  - ◆ 1.2 W
  - ◆ Only in vehicles with no auto-check systems

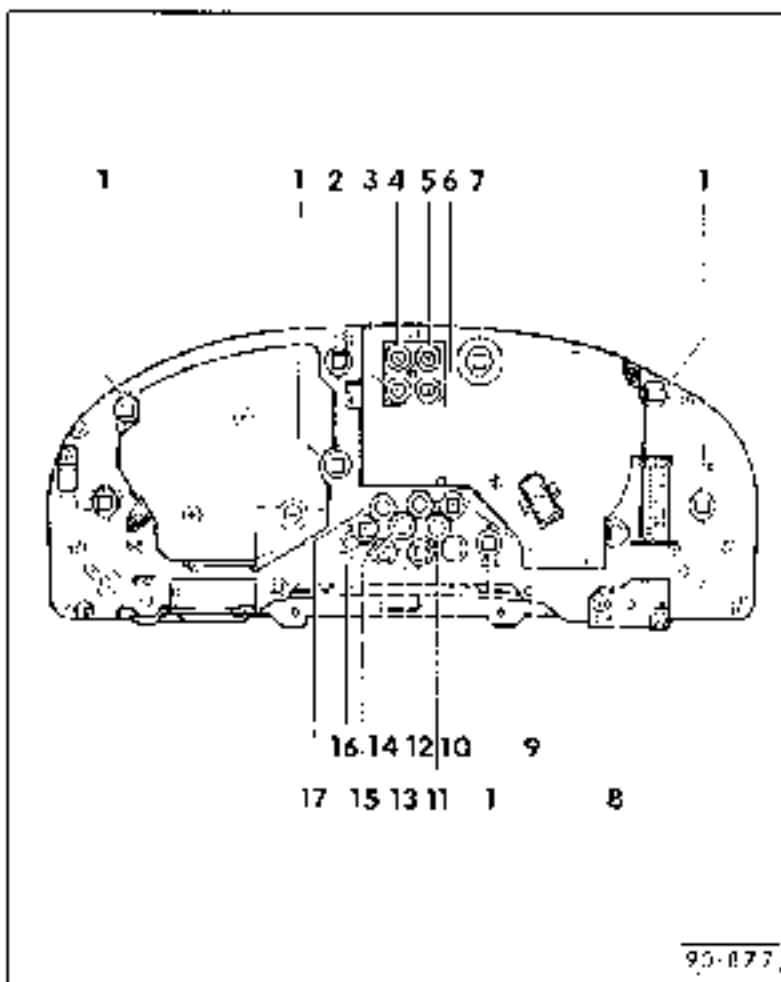

90-9

- 5 - Coolant temperature warning lamp (overheating)
  - ◆ 1.2 W
  - ◆ Only in vehicles with no auto-check systems
- 6 - Oil pressure warning lamp
  - ◆ 1.2 W
  - ◆ Only in vehicles with no auto-check system
- 7 - Left turn signal warning lamp
  - ◆ 1.2 W
- B - Digital clock illumination
  - ◆ 1.2 W
- 9 - Charge warning lamp
  - ◆ 2 W

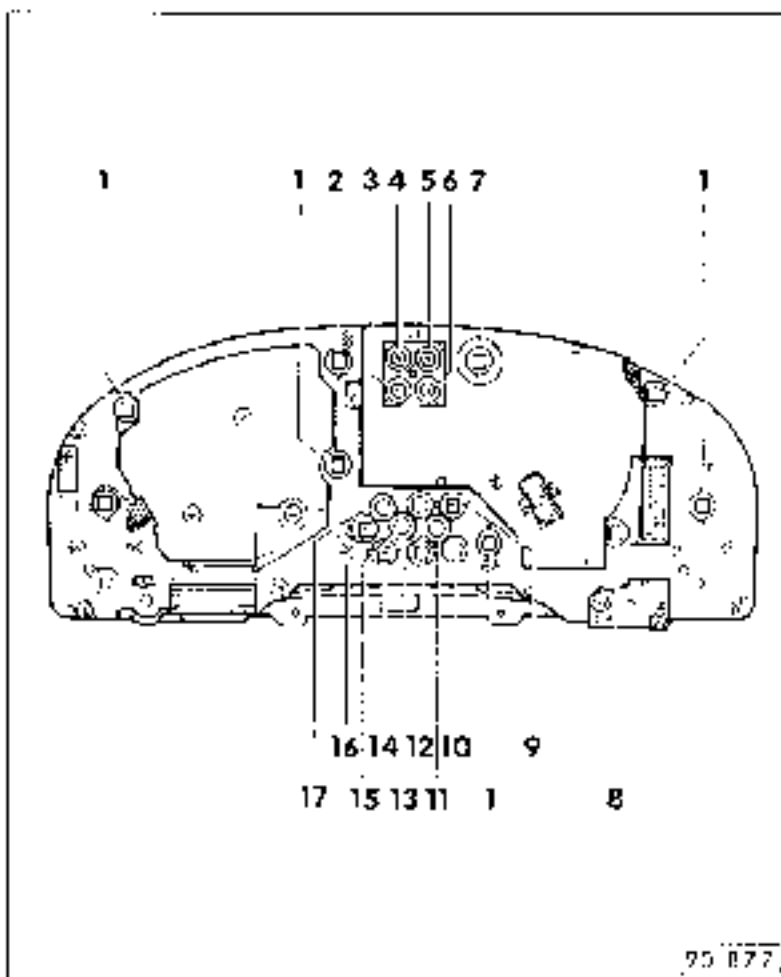

90-10



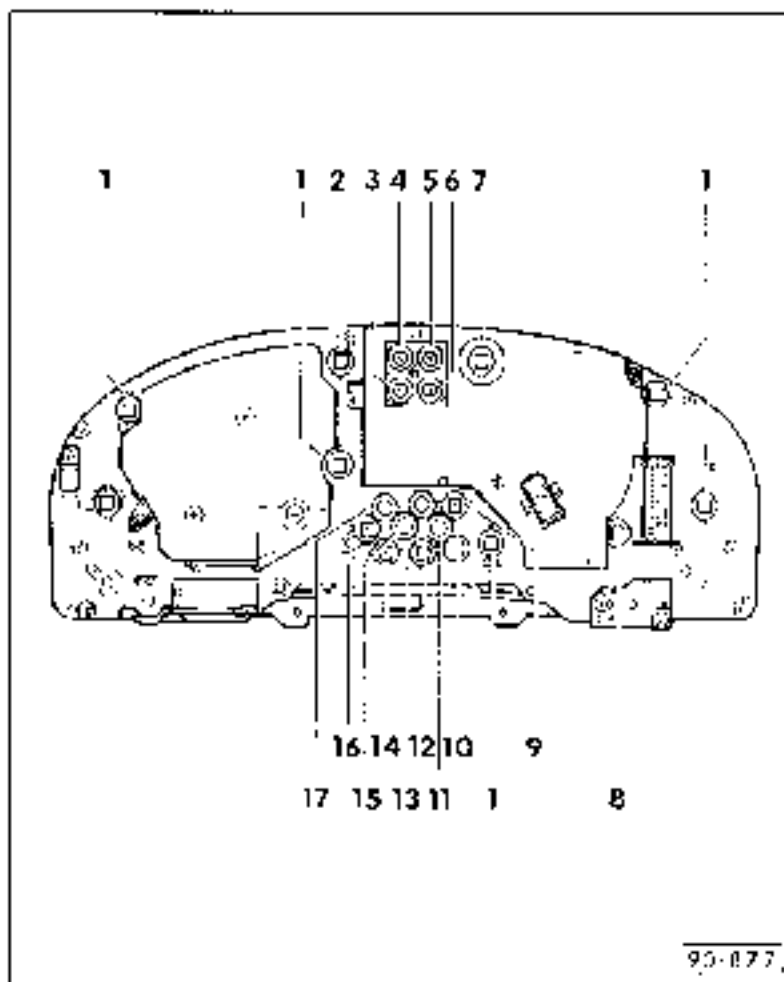

10 - Immobiliser warning lamp

- ◆ 1.2 W
- ◆ Differing assignment  
CAT 6-cylinder engine.

11 - Diesel choke warning lamp

- ◆ 1.2 W
- ◆ Differing assignment  
CAT

12 - Lamp for trailer turn-signal indicator

- ◆ 1.2 W
- ◆ Retrofitted
- ◆ Differing assignment  
Side lights/airbag/engine electronics

13 - Brake/handbrake warning lamp

- ◆ 1.2 W

90-11

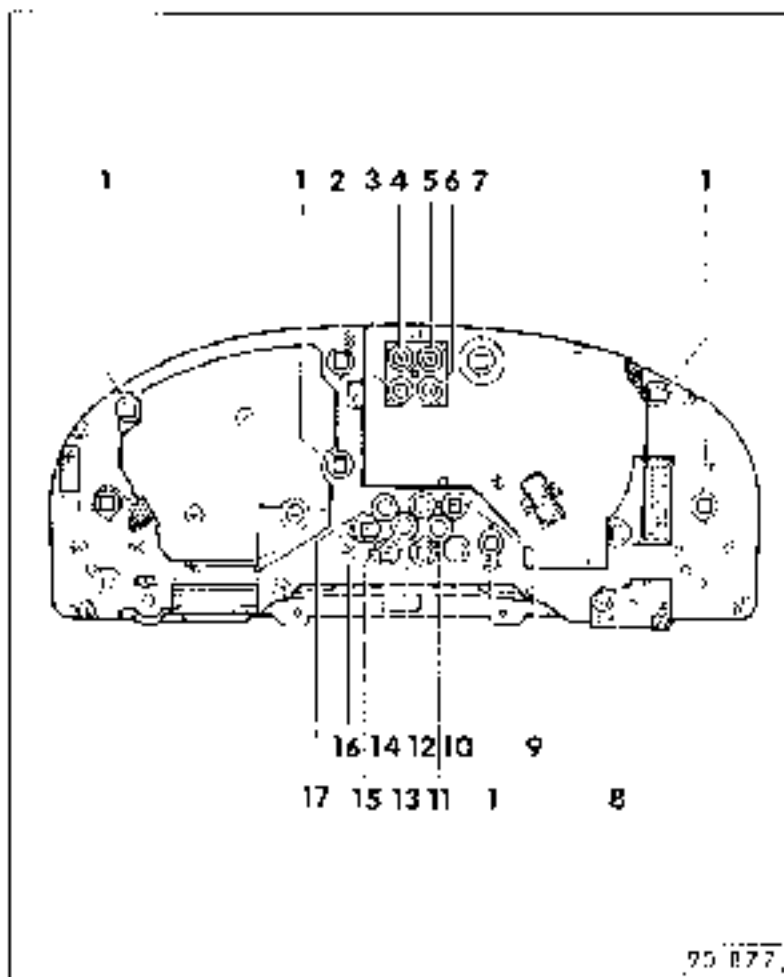

14 - Seat belt warning lamp

- ◆ 1.2 W
- ◆ Differing assignment  
Engine electronics/hazard  
warning/airbag

15 - Anti-lock braking system warning lamp

- ◆ 1.2 W

16 - Main beam warning lamp

- ◆ 1.2 W

17 - Airbag warning lamp

- ◆ 1.2 W
- ◆ Differing assignment  
Engine electronics/seat-belt  
warning

90-12

## Assignment of contacts at multi-pin dash panel insert connectors

### Contacts on blue dash panel insert multi-pin 26-pin connector

#### Notes:

- ◆ Use appropriate current flow diagram.
- ◆ Assignment of lamps in dash panel insert and assignment of illuminated symbols -> Page 90 9.

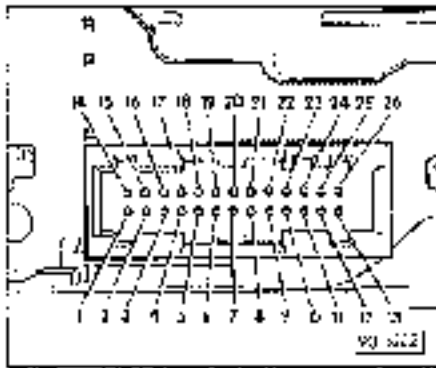

- 1 - Not used
- 2 - Not used
- 3 - Not used
- 4 - Not used
- 5 - Not used
- 6 - Not used
- 7 - Not used
- 8 - Not used
- 9 - Not used
- 10 - Negative for lamp in illuminated symbol no.15 (ABS)
- 11 - Not used
- 12 - Not used

90-13

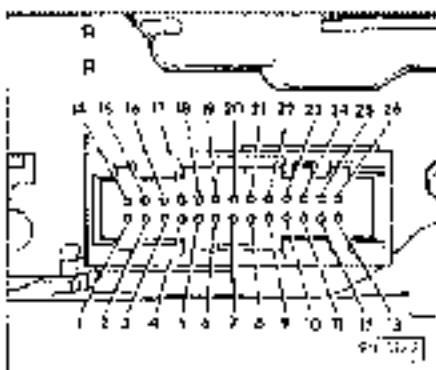

- 13 - Negative for lamp in illuminated symbol no. 12 (trailer turn-signal indicator/side lights/antiq/engine electronics)
- 14 - Not used
- 15 - Negative for fuel gauge
- 16 - Positive for electronic speedometer; connected to voltage stabiliser and lamps in illuminated symbols nos. 9, 10, 12, 13, 15, 17
- 17 - Positive for lamp in illuminated symbol no.2 (right turn-signal indicator)
- 18 - Vehicle speed signal (output)
- 19 - Not used
- 20 - Vehicle speed signal (input from travel sensor)
- ◆ Checking -> Page 30 37
- 21 - Negative for lamps in dash panel insert lighting; connected to electronic speedometer, voltage stabiliser and lamp in illuminated symbol no. 16 (main beam).
- 22 - Variable positive for dash panel insert brightness control, connected to lamps for dash panel insert lighting, lamp for digital clock lighting and multi pin connector (yellow, 26 pin, contacts 1 and 4, 6-pin plug connector)

90 14

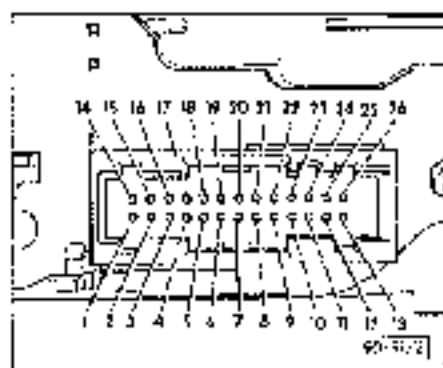

- ◀ - 23 - Positive for lamp in illuminated symbol no. 16 (Main beam)
- 24 - Negative for lamp in illuminated symbol no. 17 (air bag/engine electronics/seat belt warning)
- 25 - Positive for lamp in illuminated symbol no. 14 (seat belt warning/engine electronics/airbag)
- 26 - Negative for lamp in illuminated symbol no. 14 (seat belt warning/engine electronics/airbag)

**Contacts at yellow dash panel insert multi pin (26 pin) connector**

**Notes:**

- ◆ Use appropriate current flow diagram
- ◆ Assignment of lamps in dash panel insert and assignment of illuminated symbols -> Page 90-5.

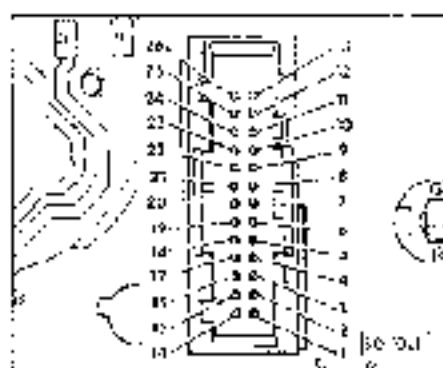

- ◀ - 1 - Positive from light switch to brightness control for instrument lighting, for lamps for dash panel insert lighting and lamp for digital clock lighting; connected to contact 4; connected to 6-pin plug connector
- 2 - Negative for coolant temperature gauge
- 3 - Positive (terminal 15), connected to lamp for digital clock lighting
- 4 - Positive from light switch; connected to contact 1; connected to 6-pin plug connector
- 5 - Positive; connected to brightness control for dash panel insert lighting
- 6 - Not used
- 7 - Not used

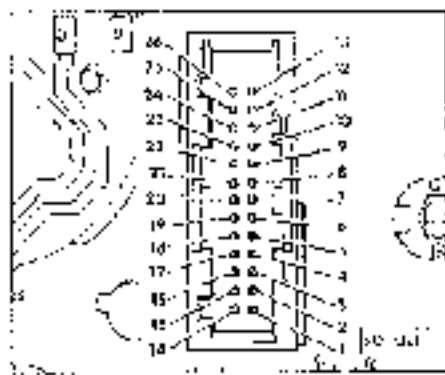

- ◀ - 8 - Negative; connected to lamps for dash panel insert lighting, to lamp in illuminated symbol no. 7 (left turn-signal indicator), to lamp for digital clock lighting, to digital clock, to lamp in illuminated symbol no. 2 (right turn-signal indicator) and to 6-pin plug connector
- 9 - Positive; connected to lamp in illuminated symbol no.7 (left turn-signal indicator)
- 10 - Negative for lamp in illuminated symbol no.5 (coolant overheating)
- 11 Negative for lamp in illuminated symbol no.4 (brake warning)
- 12 Not used
- 13 - Negative for lamp in illuminated symbol no. 8 (charge warning lamp); connected to display unit, coolant temperature warning lamp (overheating) and brake warning lamp
- 14 Not used
- 15 Not used
- 16 Not used
- 17 - Not used
- 18 - Not used
- 19 - Positive (terminal 30I) for analog clock/digital clock, 6-pin plug connector

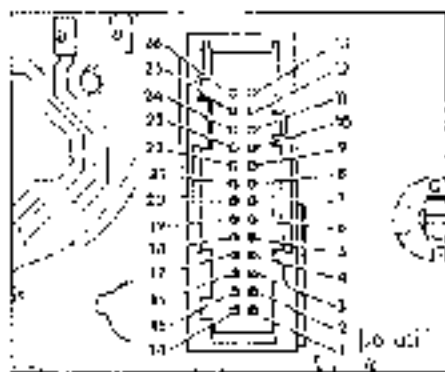

- ◀ - 20 - Not used
- 21 - Not used
- 22 - Signal input for rev counter
- 23 - Negative for rev counter, for 5-cyl. engine only (loading)
- 24 - Negative for lamp in illuminated symbol no.15 (immobiliser:CAT 6-cyl. engine)
- 25 - Negative for lamp in illuminated symbol no.13 (brake/handbrake)
- 26 - Negative for lamp in illuminated symbol no.11 (diesel choke:CAT)

## Removing and attaching multi-pin connector plugs

### Removal:

- ◀ - Use small screwdriver or plastic wedge to lift plug catch upwards -arrow- as far as it will go.

### Note:

*The plug cannot be removed unless the catch has been raised*

Pull off plug by hand

### Installation:

- Push plug by hand on as far as it will go
- Slide in the catch

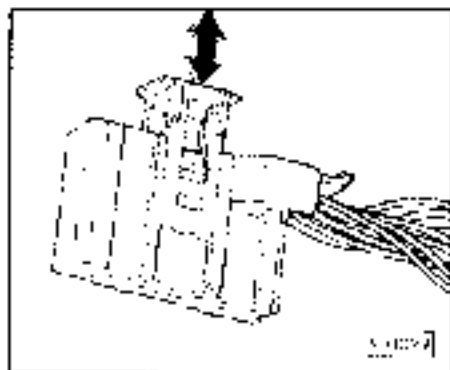

90-19

## Repairing multi-pin connector plugs

### Notes:

◆ A separate repair kit 893 998 315 must be used for repairing the connector (poor contact, loose contact, damage, open or cut, retrofitting).

- > Parts list

◆ Appropriate cavity assignment

= > "Current Flow Diagrams, Electrical Fault Finding and Fitting Locations" binder

- ◀ - Remove cable tie -C-.
- Pull inner section of plug -D- out of outer section -B-.
- Release damaged contact, pull it out and remove it from the lead.
- Insert contact F of the new lead (from repair kit) into the relevant cavity

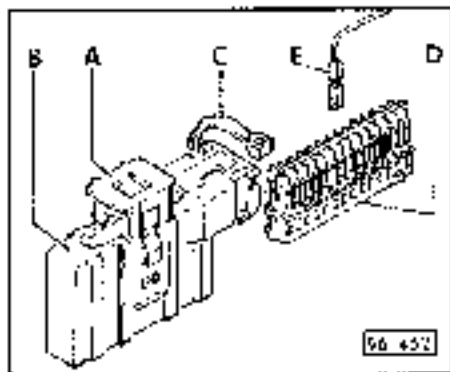

90-20

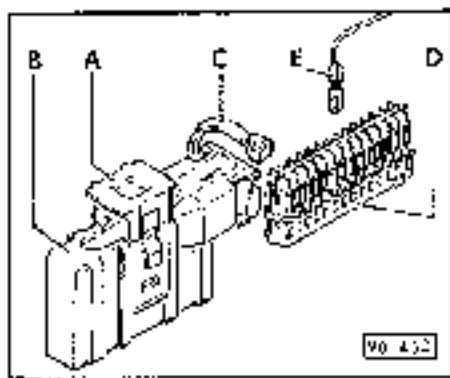

- ◀ - Slide inner section of plug -D- in until it engages and secure using cable tie -C- .  
Use provided housing to attach inserted lead to lead that has been detached from wiring harness
- Stop repaired cable and connector housing from rattling using cable tie and insulating tape.

## Checking dash panel insert components

### Checking voltage stabilizer

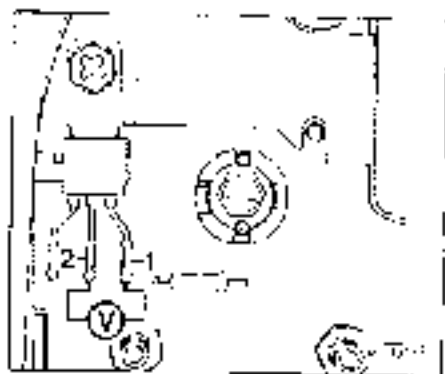

- Removing dash panel insert -> Page 90-8

**Note:**

- ◀ *Do not detach battery earthing strap; leave all plugs attached to dash panel insert.*

Check supply voltage by connecting a voltmeter between positive input -1- and earth -2-. Switch ignition on

Specified value: approx. battery voltage

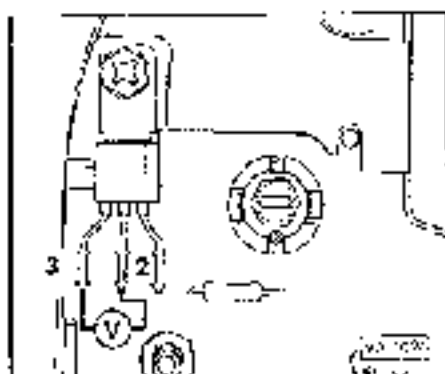

- ◀ - If specified value is not attained, locate open circuit using current flow diagram and rectify fault.

Check output voltage by connecting a voltmeter between positive output -3- and earth -2-. Switch ignition on

- Specified value: 9,8 ... 10,4 V

- If specified value is not attained, replace circuit board.

## Checking and adjusting fuel gauge

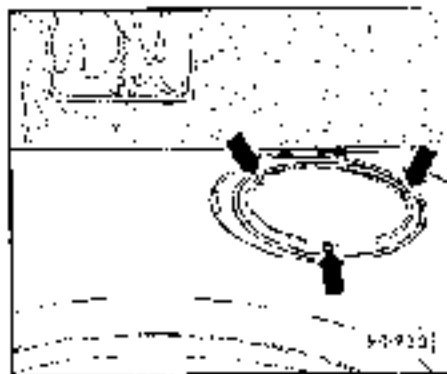

- Lift up carpet at front right of luggage compartment.
- Remove self-tapping screws -arrows- and detach cover.

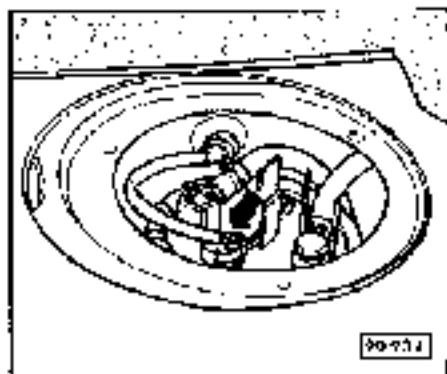

- Pull connector -arrow- off fuel gauge sensor.

90-23

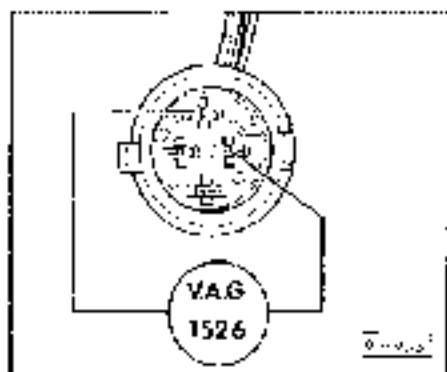

- Use auxiliary cable to connect hand-held multimeter V.A.G. 1526 between contacts of connector for fuel gauge sensor and switch to DC voltage measuring range.
- Switch ignition on.  
Specified value: 9,8 .. 10,4 V
- Switch off ignition.  
If specified value is not attained, locate open circuit using current flow diagram and rectify fault or replace voltage stabilizer  
-> Page 90-22.

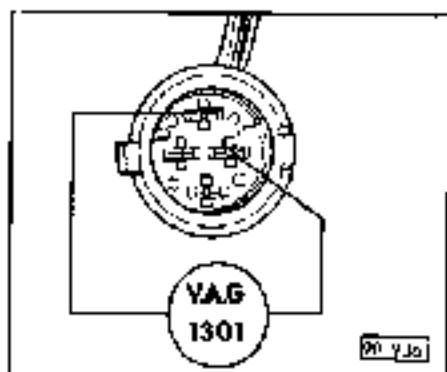

- Connect tester V.A.G. 1301 to tank sensor lead plug connector in trunk using auxiliary cable.
- Adjust V.A.G. 1301 tester as follows:
  - 280
- Switch on ignition for at least 2 minutes.

### **Note:**

*When making connection, ensure that the cavities in the connector are not pushed back.*

90-24

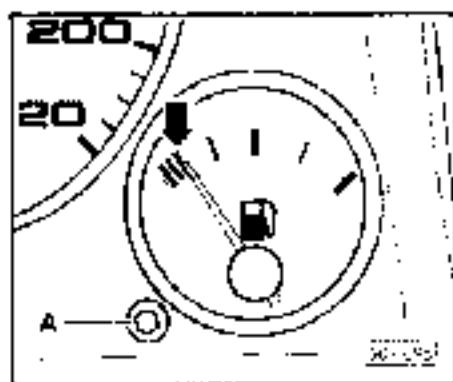

- ◀ - The needle on the gauge must be at the right edge of the third red mark (reserve zone) arrow.
- Whilst taking the reading, tap your finger lightly against the glass on the dash panel insert.
- If the specified value is not attained, use pointed-nose pliers to carefully pull off the adjusting screw cap.

**Note:**

To avoid scratches, cover the glass panel of the dash panel insert with a cloth.

- Turn adjusting screw -A- using Allen key/screwdriver to set pointer to specified value.

**Notes:**

- ◆ Whilst performing adjustment, tap your finger lightly against the glass on the dash panel insert.
- ◆ Do not start the engine.
- If the measured value is still not attained, replace the gauge.

**Checking oil pressure switch – vehicles with mini-check system**

- Removing dash panel insert -> Page 80-8
- Detach 14 pin multi pin connector from dash panel insert.
- Connect test adapter V.A.G 1598:13 to 14-pin connector (do not connect test adapter to dash panel insert).

**Checking 0.3 bar oil pressure switch.**

- Connect hand multimeter V.A.G 1526 to test box V.A.G 1598, socket 17 and earth using auxiliary cable and switch to resistance measuring range.
  - Specified value 0 Ω
- Run engine.
  - Specified value ∞ Ω
- Stop engine.

If specified value is not attained, locate open circuit using current flow diagram and rectify or replace oil pressure switch.



#### Checking 0.9/1.8 bar oil pressure switch.

- Connect hand multimeter V.A.G 1526 to test box V.A.G 1598, socket 14 and earth using auxiliary cable and switch to resistance measuring range.
  - Specified value  $\infty \Omega$
- Run engine (engine speed more than 2800 rpm)
  - Specified value  $0 \Omega$
- Stop engine.
- If specified value is not attained, locate open circuit using current flow diagram and rectify or replace oil pressure switch.

#### Checking oil pressure switch – vehicles with auto-check system

##### ● Dash panel insert removed

Detach 26 pin multi pin connector (wired from dash panel insert).

- Connect test adapter V.A.G 1598/4 to 26-pin connector (do not connect test adapter to dash panel insert).

##### Checking 0.3 bar oil pressure switch.

- Connect hand multimeter V.A.G 1526 to test box V.A.G 1598, socket 19 and earth using auxiliary cable and switch to resistance measuring range.
  - Specified value  $0 \Omega$
- Run engine.
  - Specified value  $\infty \Omega$
- Stop engine.
- If specified value is not attained, locate open circuit using current flow diagram and rectify or replace oil pressure switch.

#### Checking 0.9/1.8 bar oil pressure switch.

- Connect hand multimeter V.A.G 1526 to test box V.A.G 1598, socket 17 and earth using auxiliary cable and switch to resistance measuring range.
  - Specified value  $\infty \Omega$
- Run engine (engine speed more than 2800 rpm)
  - Specified value  $0 \Omega$
- Stop engine.
- If specified value is not attained, locate open circuit using current flow diagram and rectify or replace oil pressure switch

90-29

#### Checking coolant temperature gauge

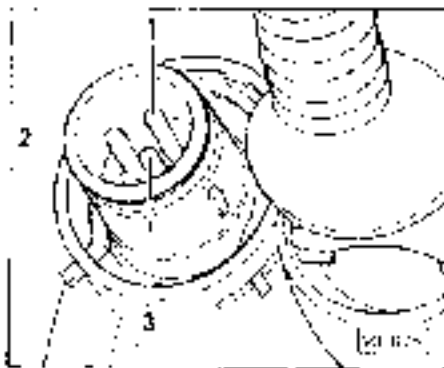

#### Vehicles with coolant temperature control switch (overheating) - F14 and coolant temperature gauge sensor -G2

Switch/sensor connections:

- 1 - Actuation of coolant temperature warning lamp (overheating)
- 2 - Earth
- 3 - Actuation of coolant temperature gauge

Location in 4-cylinder engine. Back of coolant connection.

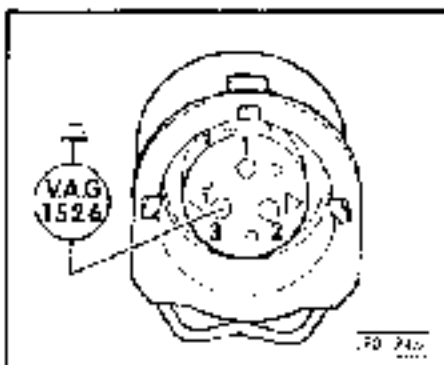

- Remove connector from switch/sensor
  - Use auxiliary cable to connect hand-held multimeter V.A.G 1526 between contact 3 of plug and earth and switch to DC voltage measuring range.
  - Switch ignition on.
    - Specified value: 9.8 ... 10.4 V
  - Switch off ignition.
  - If specified value is not attained, locate open circuit using current flow diagram and rectify fault or check voltage stabilizer
- > Page 90 22.

90 30

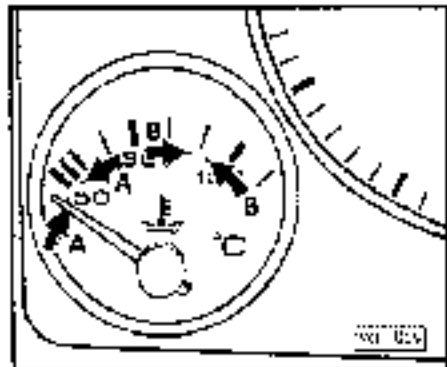
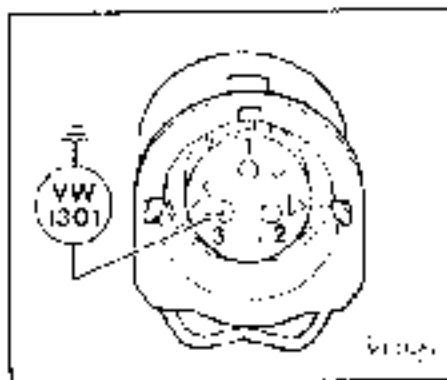

- ◀ - Connect tester V.A.G 1301 to connector contact -3- and earth.  
Adjust V A G 1301 tester as follows:
  - cold - 560
  - hot - 58
- Switch ignition on.

- ◀ At a test setting of 560, the needle must be within the tolerance range of the two test positions **A** in the coolant temperature gauge.  
At a test setting of 58, the needle must be within the tolerance range of the two test positions **B** on the coolant temperature gauge.
  - If the specified values are not attained in spite of this, check the voltage supply to the coolant temperature gauge, including the voltage stabilizer.
  - If these are O.K., replace the gauge.
  - If the specified values are not attained, but the indicating instrument either does not function or gives an incorrect reading, check earth connection to contact 2 or replace defective coolant temperature sensor

— 90-31 —

#### Checking coolant temperature warning lamp (overheating)

##### **Note:**

*Connections on coolant temperature control switch (overheating)/coolant temperature sensor and fitting location -> Page 90/30.*

- Remove plug from coolant temperature warning switch (overheating).

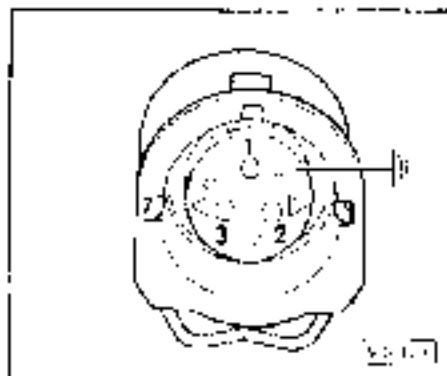

- ◀ - Connect contact -1- to earth using auxiliary cable.  
Run engine
  - Warning lamp in display unit (for mini-check system) must flash.
  - If the warning lamp does not flash, check bulb (1.2 W) or locate open circuit using current flow diagram and remedy
  - If this is O.K., check display unit for mini-check system in dash panel insert in line with troubleshooting instructions
  - > "Current Flow Diagrams, Electrical Fault Finding and Fitting Locations" binder

— 90-32 —

## Vehicles with electronic thermo switch -F76

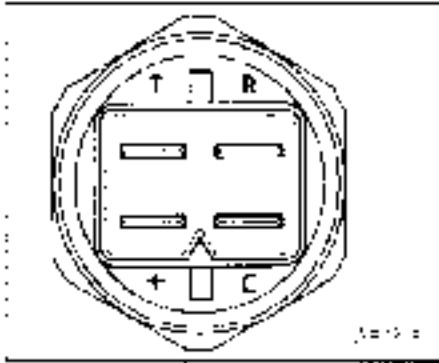

### Connections at electronic thermo switch:

- + - Voltage supply, term. 15a
- C - Actuation of coolant temperature warning lamp (overheating)
- R - Air conditioner safety shutdown
- I - Actuation of coolant temperature gauge

### Locations:

- ◆ 4-cylinder engine, on front or back of coolant connection
- ◆ 5-cylinder engine on front of coolant connection
- ◆ 6-cylinder engine, at coolant pipe on right, between plenum chamber and engine

90-33

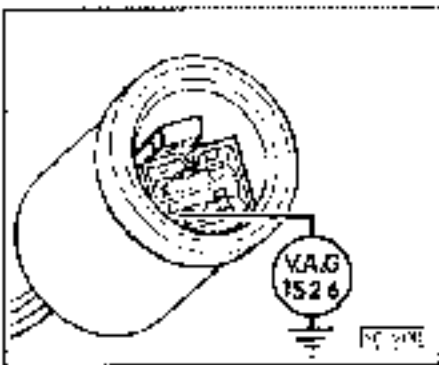

- Disconnect plug from thermo switch.
- ◆ Use auxiliary cable to connect hand-held multimeter V.A.G 1526 between contact -T- of plug and earth and switch to DC voltage measuring range.
- Switch ignition on.
  - Specified value: 9,8 ... 10,4 V
- Switch off ignition.
- If specified value is not attained, locate open circuit using current flow diagram and rectify fault or check voltage stabilizer  
-> Page 90-32.

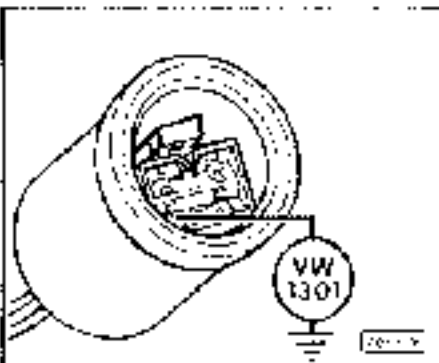

- ◆ Connect tester V.A.G 1301 to connector contact -I- and earth using auxiliary cable.
- Adjust V.A.G 1301 tester as follows:
  - cold - 360
  - hot - 58
- Switch ignition on.

90-34

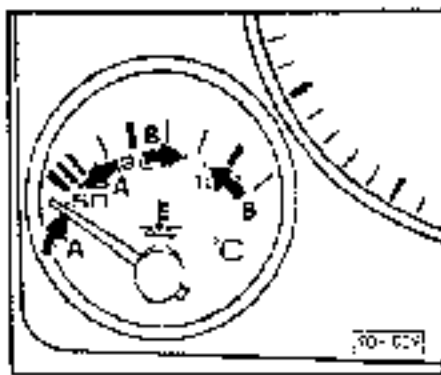

- 4 At a test setting of 560, the needle must be within the tolerance range of the two test positions A in the coolant temperature gauge.

At a test setting of 58, the needle must be within the tolerance range of the two test positions B on the coolant temperature gauge.

- If specified values are not attained, locate open circuit using current flow diagram and rectify or check voltage stabilizer -> 77.
- If these are OK, replace the gauge.

If the specified values are attained, but the indicating instrument fails to function or gives an incorrect reading, check earth connection to electronic thermo switch or replace defective thermo switch.

#### Checking coolant temperature warning lamp (overheating)

##### Note:

Connections at electronic thermo switch -> Page 30/31

- Disconnect plug from thermo switch.

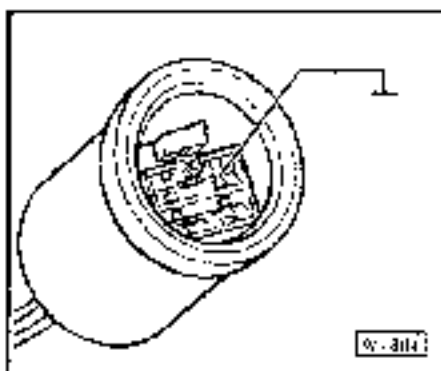

- 4 Connect contact C to earth using auxiliary cable
- Run engine.
  - Warning lamp in display unit for mini-check system must flash.

If the warning lamp does not flash, check bulb (1.2 W) or its cable open circuit using current flow diagram and remedy

If this is OK, check display unit for mini check system in dash panel insert in line with troubleshooting instructions.

- > "Current Flow Diagrams, Electrical Fault Finding and Firing Locations" binder

## Checking speedometer sensor

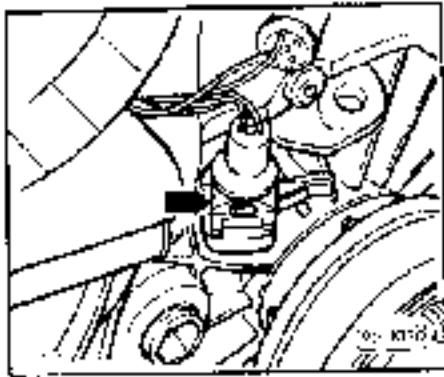

Location: On left of gearbox next to drive shaft flange

- Squeeze spring clip and pull 3-pin connector (arrow) from sensor
- Connect test adapter V.A.G 1501 to speedometer sensor.

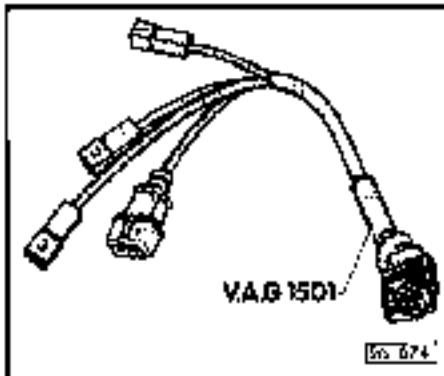

- Connect hand-held multimeter V.A.G 1526 between flat-pin plugs 2 and 3 of test adapter V.A.G 1501 and switch to resistance measuring range 2 k $\Omega$ .
- Release hand brake, move gear lever to neutral or engage position N (automatic gearbox);  
Move vehicle forwards and backwards slightly

### Warning

Test must be performed on a perfectly horizontal surface.

90-37

Specified value:

- Reading on hand-held multimeter V.A.G 1526 must fluctuate between 0  $\Omega$  and  $\infty \Omega$ .
- If specified value still not attained, replace the speedometer sensor.
- If specified value attained but speedometer still not working, measure sensor signal at instrument panel wiring loom.

## Checking speedometer signal at instrument panel wiring harness

- Dash panel insert removed:
  - Detach 26-pin multi-pin connector (blue) from dash panel insert.
  - Connect test adapter V.A.G 1598/4 to 26-pin connector (do not connect test adapter to dash panel insert);
  - Connect hand-held multimeter V.A.G 1526 between contacts 20 and 21 of test box V.A.G 1598 and switch to resistance measuring range.

90-38

- Release hand brake, move gear lever to neutral or engage position N (automatic gearbox).

**Warning**

Test must be performed on a perfectly horizontal surface.

- Move vehicle forwards and backwards slightly.

Specified value:

- Reading on hand-held multimeter V.A.G 1526 must fluctuate between 0  $\Omega$  and  $\infty \Omega$ .
- If specified value is not attained, eliminate open circuit using current flow diagram.
- If specified value is attained but speedometer is still not working, check speedometer voltage supply as per current flow diagram or use troubleshooting instructions to check speedometer.
- > "Current Flow Diagrams, Electrical Fault Finding and Fitting Locations" binder

### Checking engine speed signal

- Dash panel insert removed
- Detach 26-pin multi-pin connector (yellow) from dash panel insert.
- Connect measuring adapter V.A.G 1598/4 between 26-pin plug and dash panel insert.
- Connect test box V.A.G 1598 to test adapter V.A.G 1598/4.
- Use auxiliary cable to connect red terminal of V.A.G 1362 non-tester to socket 19 and black terminal to socket 22 of test box V.A.G 1598 and switch to engine speed measurement.
- Run engine.
  - Specified value: Engine speed
- If specified value is not attained, eliminate open circuit using current flow diagram.
- If specified value attained but rev counter still not working, check rev counter voltage supply as per current flow diagram.
- > "Current Flow Diagrams, Electrical Fault Finding and Fitting Locations" binder

## Removal and installation of dash panel insert components:

### VDO dash panel insert

Removing and installing dash panel insert -> Page 90-8.

- 1 - Rev. counter
  - ◆ Checking engine speed signal -> Page 90-31
  - ◆ Removing and installing -> Page 90-31
- 2 - Digital clock
  - ◆ Removing and installing -> Page 90-32
- 3 - Symbol panel
  - ◆ For indicator/warning lamps

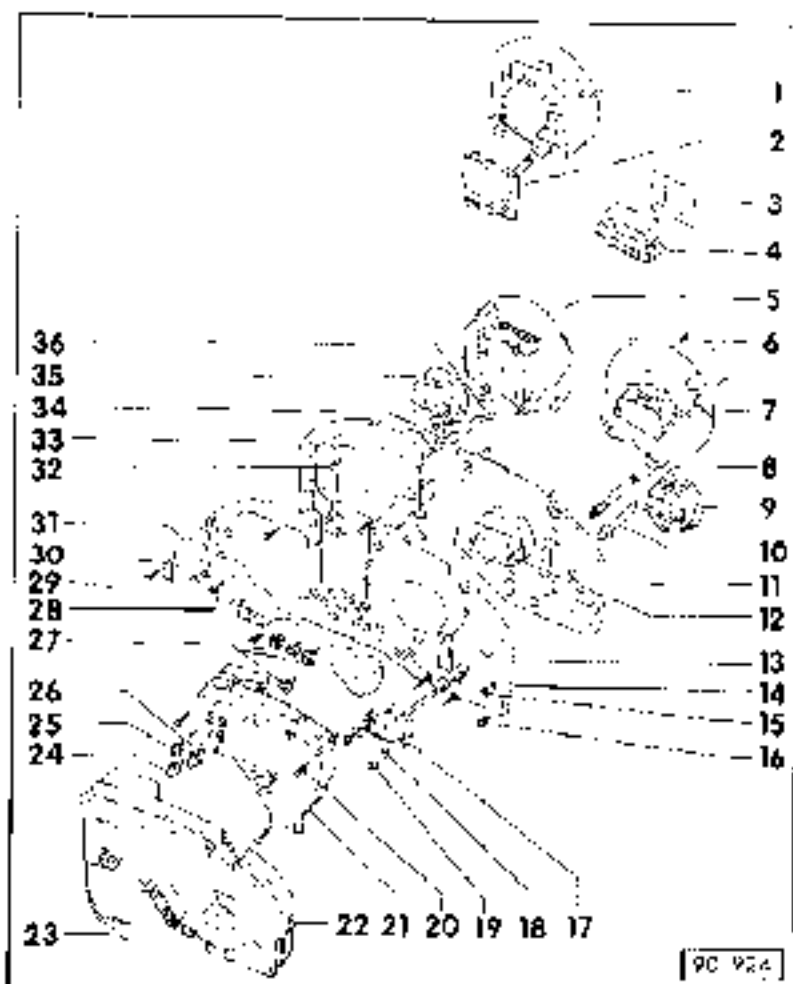

90-41

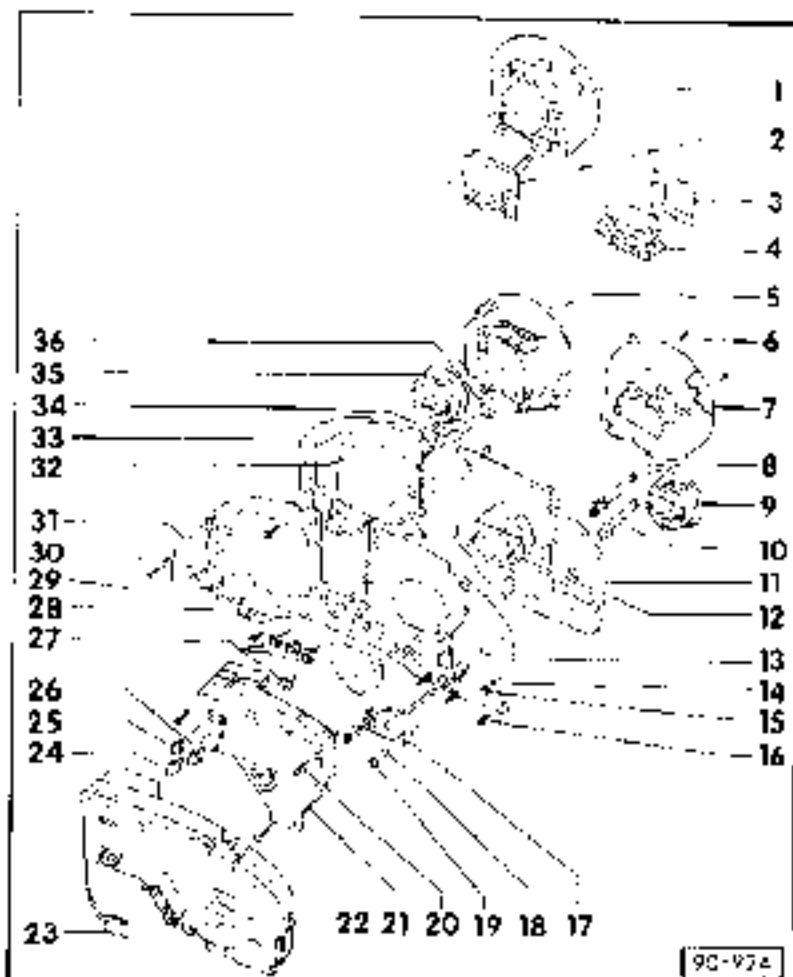

- 4 - Light guide
  - ◆ For dash panel insert housing
- 5 - Speedometer
  - ◆ Checking speedometer sensor => Page 90-37
  - ◆ Removing and installing -> Page 90-50
- 6 - Securing bolts
- 7 - Analog clock
  - ◆ For vehicles with no rev counter
  - ◆ Removing and installing -> Page 90-53
- 8 - Adjuster
  - ◆ For digital/ Analog clock

90-42



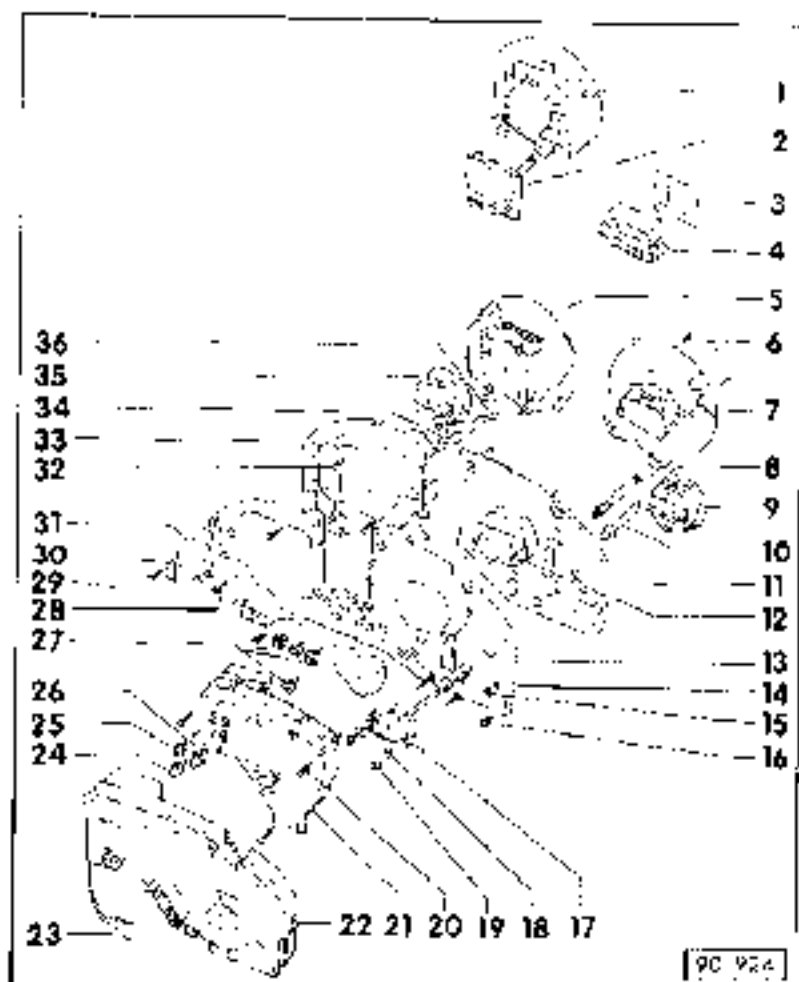

- 9 - Coolant temperature gauge.
  - ◆ Checking.
  - ◆ Vehicles with coolant temperature control switch (overheating) -F14 and coolant temperature gauge sensor -G2 -> Page 90-30
  - ◆ Vehicles with electronic thermo switch -F76 -> Page 90-33
  - ◆ Removing and installing -> Page 90-32

- 10 Rotating pin
  - ◆ For dash panel insert brightness/auto check system button
- 11 - Mounting plate
  - ◆ For rev counter/analog clock

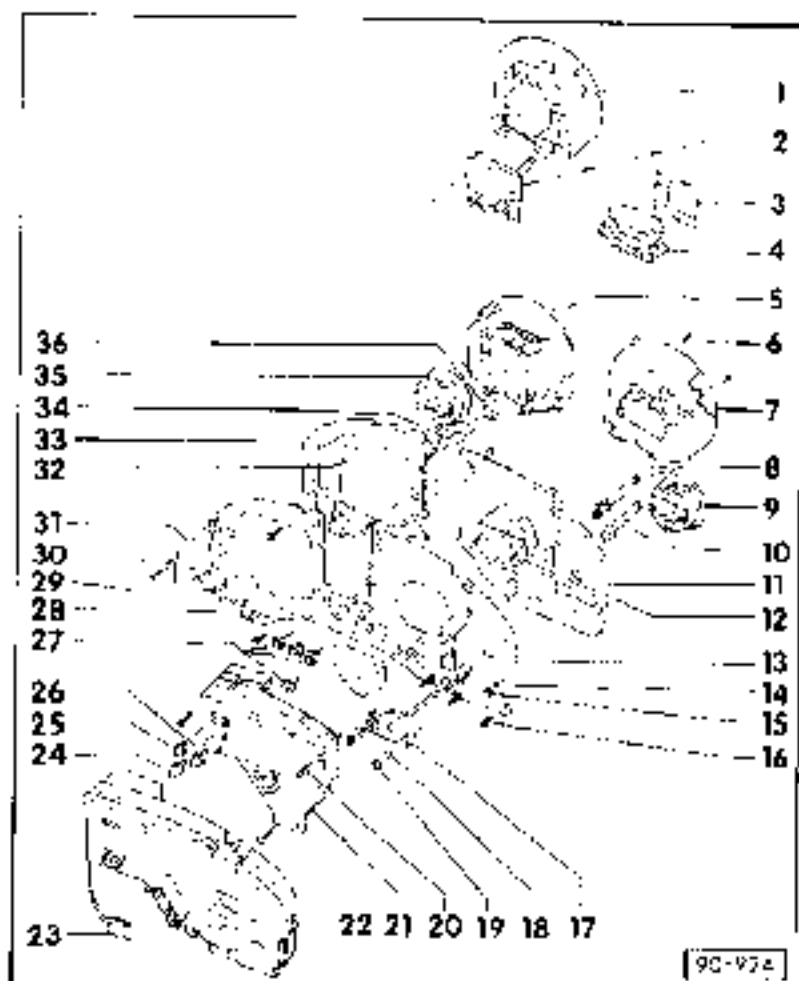

- 12 Securing bolt
- 13 - Printed circuit board
  - ◆ Assignment of multi-pin connectors -> Page 90-33 onwards
  - ◆ Removing and installing -> Page 90-49
  - ◆ Removing and attaching multi-pin connector -> Page 90-19
  - ◆ Repairing multi-pin connector -> Page 90-20
- 14 Corrugated washer
- 15 - Hexagon nut M4
- 16 - Securing bolt

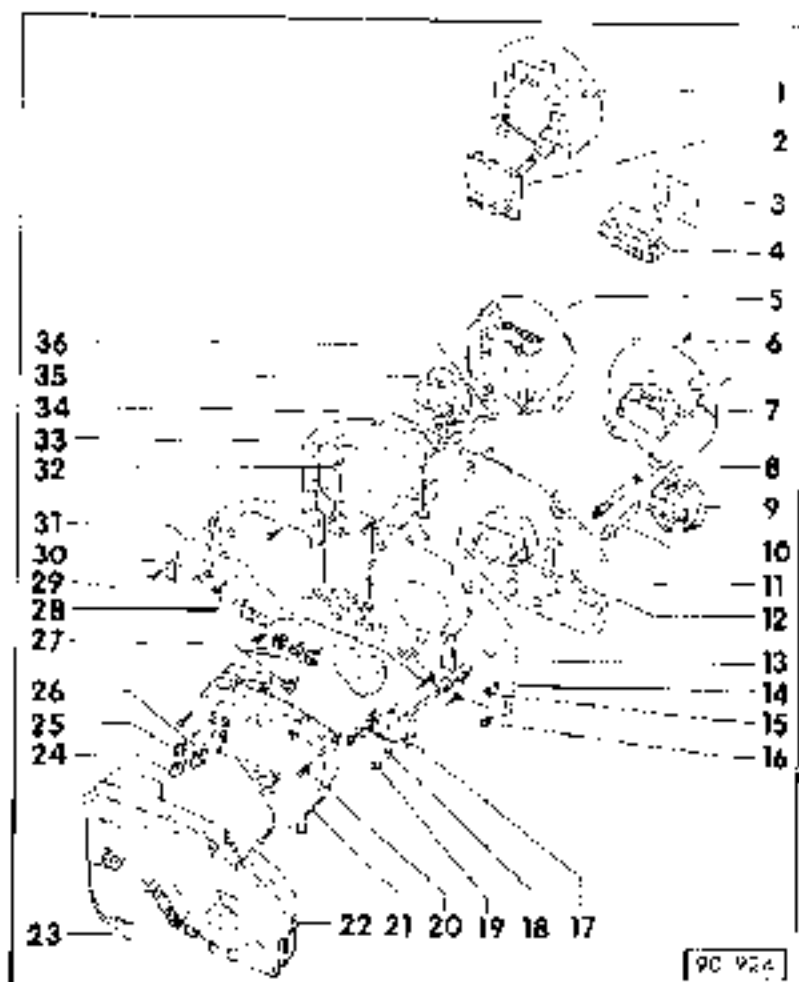

- 17 - Controller
  - ◆ For dash panel insert, switch and instrument lighting
  - ◆ Removing and installing - > Page 90-71
- 18 - Washer
- 19 - Hexagon nut M3
- 20 - Securing bolt
  - ◆ for mini-check/auto-check system/on-board computer
- 21 - Display unit
  - ◆ For mini-check system
  - ◆ Removing and installing - > Page 90-72
  - ◆ checking
  - > "Current Flow Diagrams, Electrical Fault Finding and Fitting Locations" binder

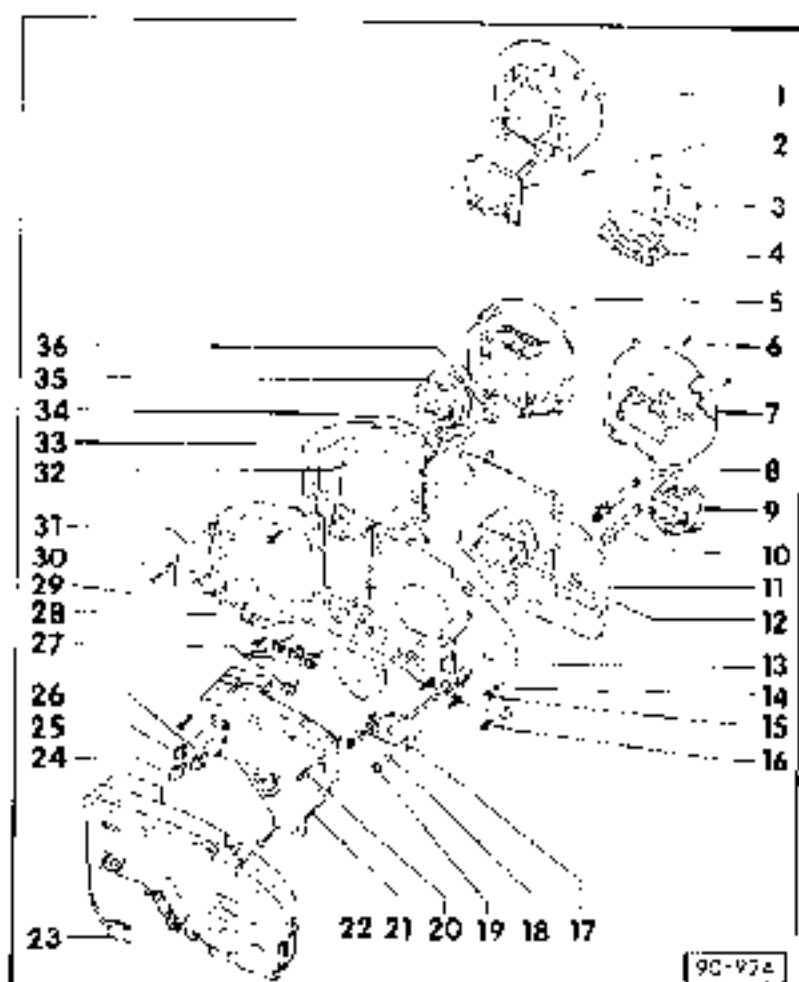

- 22 - Display unit
  - ◆ for auto-check system/on-board computer
  - ◆ Removing and installing - > Page 90-72
  - ◆ checking
  - > "Current Flow Diagrams, Electrical Fault Finding and Fitting Locations" binder
- 23 - Controller
  - ◆ For range calibration with on-board computer
- 24 - Coolant temperature warning lamp (overheating)
  - ◆ Checking
  - ◆ Vehicles with coolant temperature control switch (overheating) -F14 and coolant temperature gauge sensor -G2 - > Page 90-30
  - ◆ Vehicles with electronic thermo switch -F76 - > Page 90-33

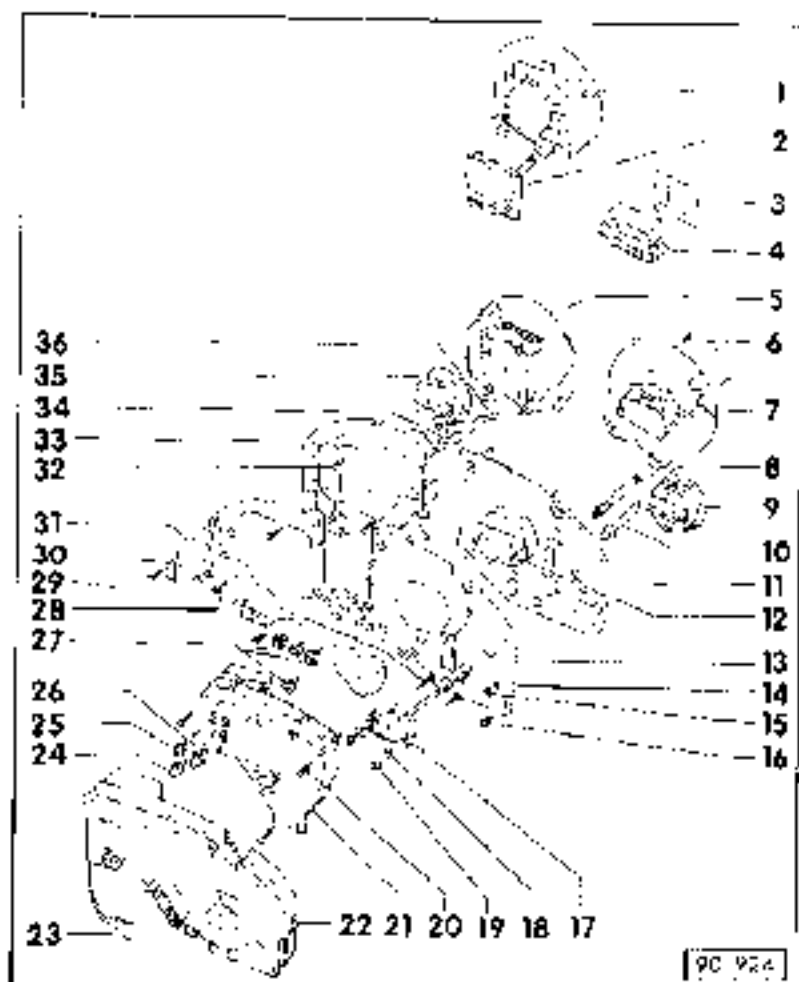

- 25 - Brake warning lamp
- 26 - Oil pressure warning lamp
- 27 - Warning and indicator lamps  
◆ Assignment -> Page 90-9
- 28 - Corrugated washer
- 29 - Hexagon nut M4
- 30 - Voltage stabiliser  
◆ Checking -> Page 90-22  
◆ Removing and installing -> Page 90-73
- 31 - Heat sink
- 32 - Securing bolt  
◆ For speedometer

90-47

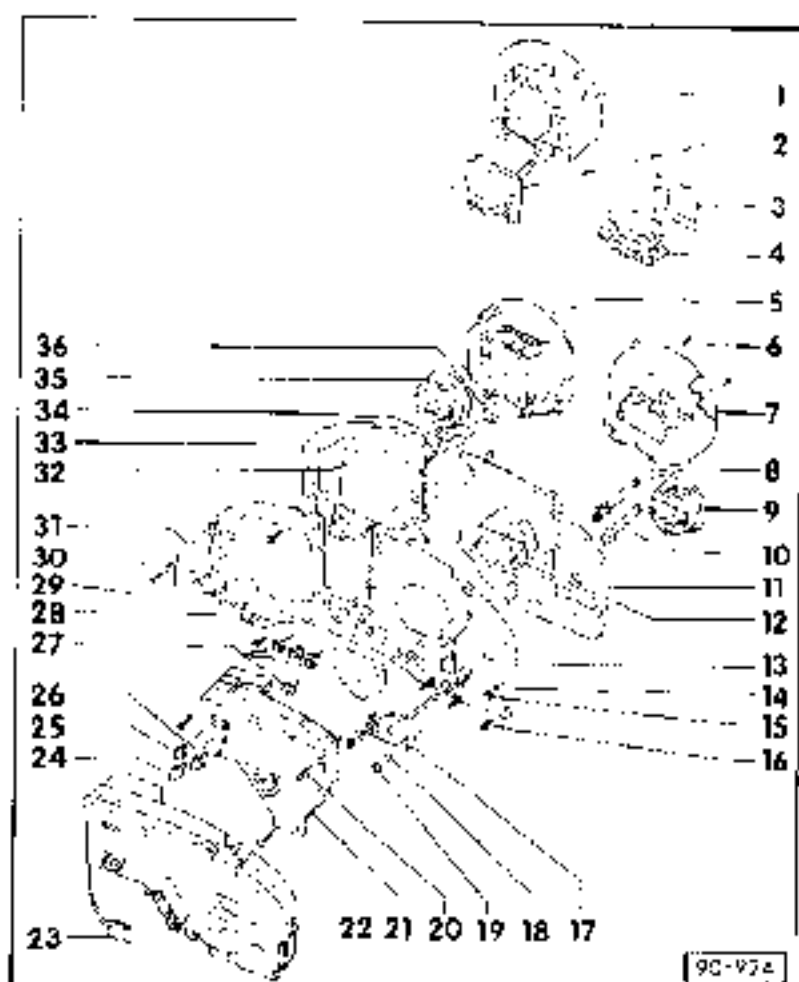

- 33 - Mounting plate  
◆ For speedometer
- 34 - Adjusting screw  
◆ For fuel gauge
- 35 - Fuel gauge  
◆ Checking -> Page 90-20  
◆ Removing and installing -> Page 90-51
- 36 - Felt ring

90-48

## Removing and installing VDO printed circuit board

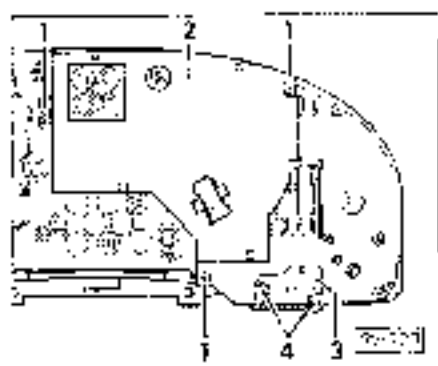

- ◀ - Unscrew hexagon nut -4- with washers and remove brightness control -3- for dash panel insert lighting.  
Release fastening screws -1- and remove display unit for mini check system-2-.

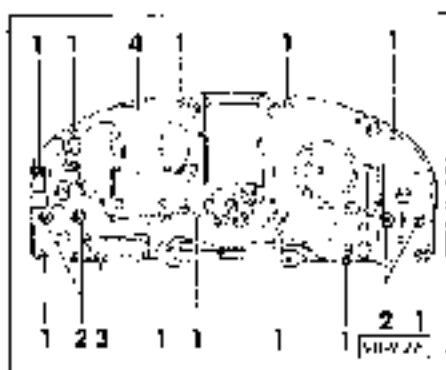

- ◀ - Remove fastening screws -1- and securing nuts -2-.
- dash panel insert with analog clock: Pull off control plate for analogue clock => Page 90-54
- Press back catch -3- and carefully remove printed circuit board -4-.

### **Note:**

*Remove carefully to avoid breakage!*

90-49

## Removing and installing VDO front surround

Removing printed circuit board => Page 90-49

- Remove base plates for analog clock/and rev counter and speedometer from front surround.

## Removing and installing VDO speedometer

Removing printed circuit board => Page 90-49

- ◀ - Unscrew fastening screws -1- for speedometer
- Remove base plate -2- for speedometer from front surround
- Carefully remove speedometer from base plate.

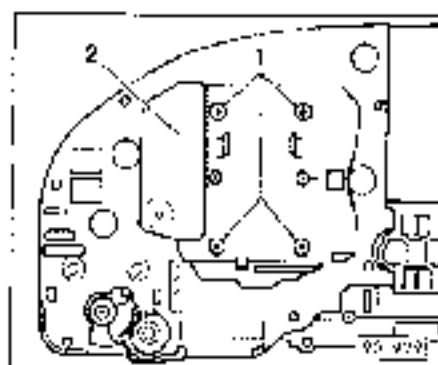

90-50

### Removing and installing VDO rev counter

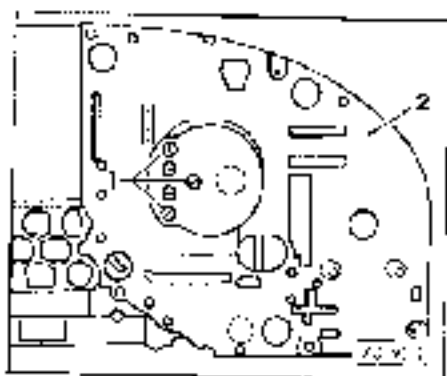

- ◀ - Removing printed circuit board => Page 90-49
- Unscrew fastening screws -1- for rev counter.
- Remove base plate -2- for rev counter from front surround.
- Carefully remove rev counter from base plate.

### Removing and installing VDO fuel gauge

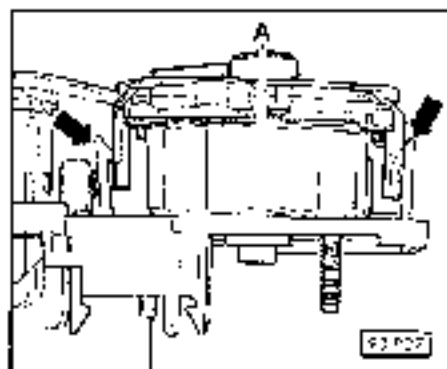

- ◀ - Removing printed circuit board => Page 90-49
- Press back catches -arrows- and remove fuel gauge -A- from base plate.

90-51

### Removing and installing VDO coolant temperature gauge

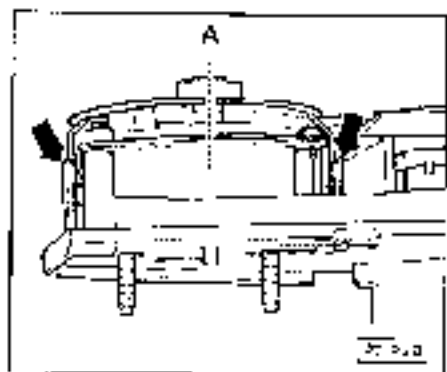

- ◀ - Removing printed circuit board => Page 90-49
- Press back catches -arrows- and remove coolant temperature gauge -A- from base plate.

### Removing and installing VDO digital clock

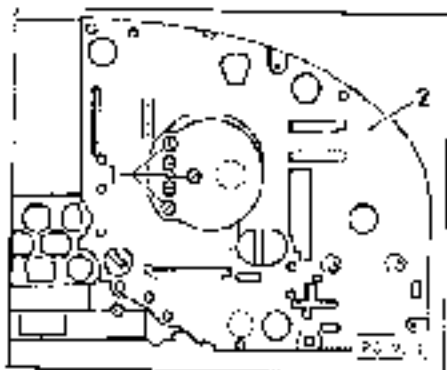

- ◀ - Removing printed circuit board => Page 90-49
- Unscrew fastening screws -1- for rev counter.
- Remove base plate -2- for rev counter from front surround.
- Carefully remove rev counter from base plate.

90-52

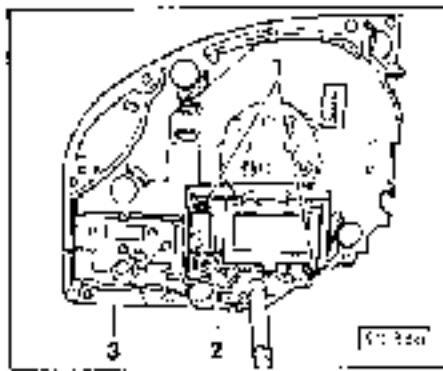

- ◀ - Unscrew fastening screws -1- for digital clock.  
Remove digital clock -2- from base plate -3- for rev counter.

### Removing and installing VDO analogue clock

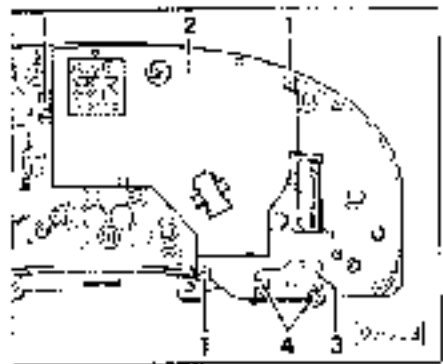

- ◀ Unscrew hexagon nuts -4- with washers and remove brightness control -3- for dash panel insert lighting.  
Release fastening screws -1- and remove display unit for tach check system-2-.

90-53

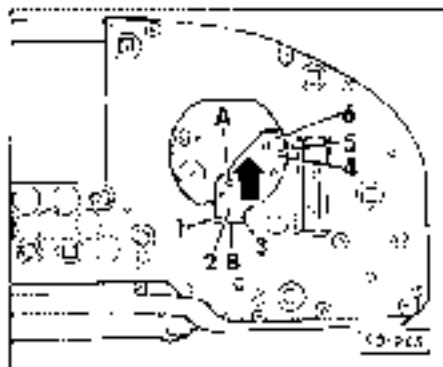

- ◀ - Press back catch -A- in direction of arrow and remove contact plate -B-.

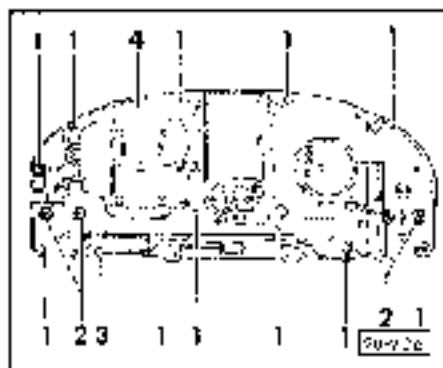

- ◀ - Remove fastening screws -1- and securing nuts -2-.
- Press back catch -3- and carefully remove printed circuit board -4-.

**Note:**

*Remove carefully to avoid breakage!*

- Remove base plate for analog clock from front surround.

90-54

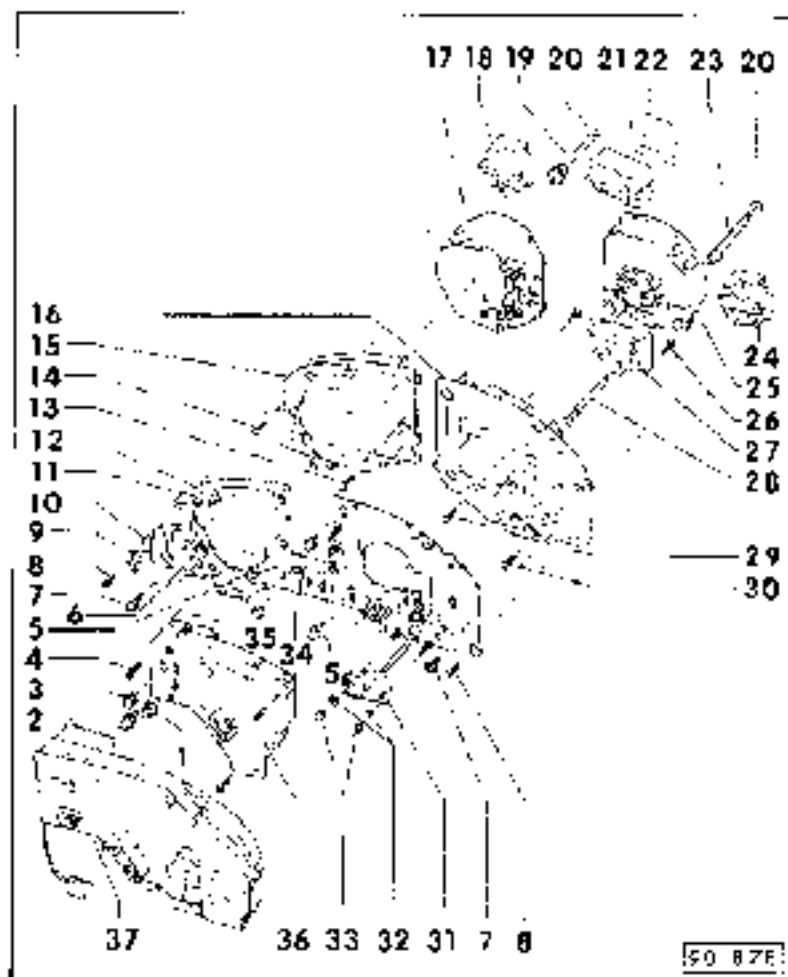

## Nippon Seiki dash panel insert

Removing and installing dash panel insert -> Page 80-8.

- 1 - Oil pressure warning lamp
- 2 - Coolant temperature warning lamp (overheating)
  - ◆ Checking
  - ◆ Vehicles with coolant temperature control switch (overheating) -F14 and coolant temperature gauge sensor G2 -> Page 80-30
  - ◆ Vehicles with electronic thermo switch -F7E -> Page 80-31
- 3 - Brake warning lamp

90-55

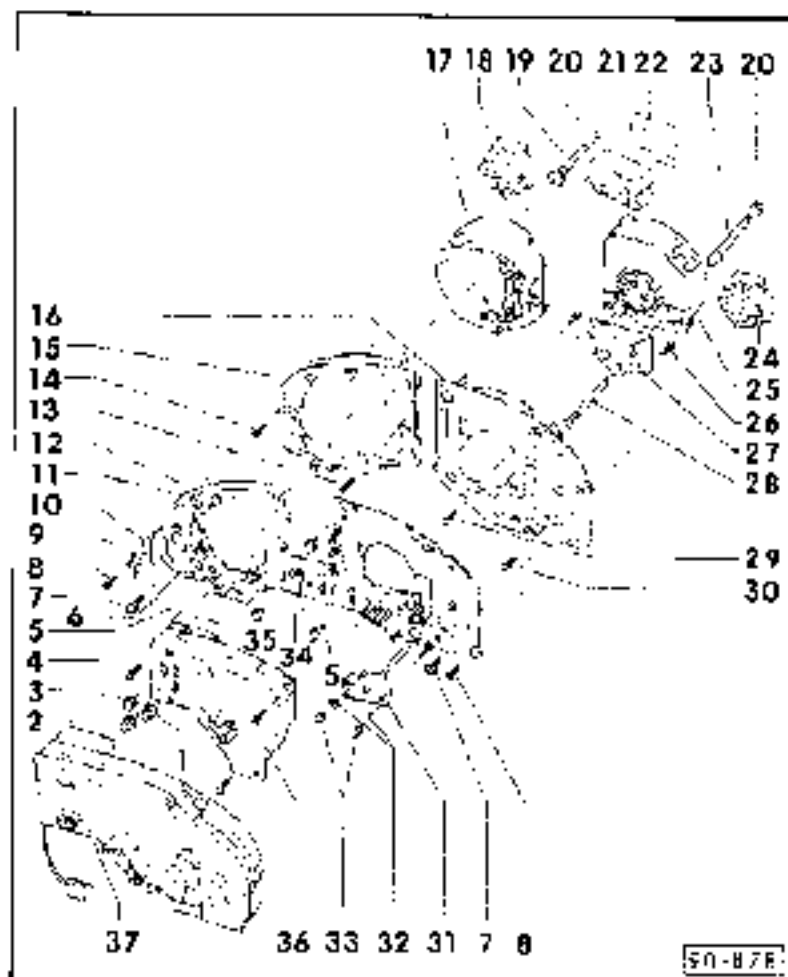

- 4 - Securing bolt
  - ◆ for mini-check/auto-check system/basic computer
- 5 - Lamps for dash panel lighting
- 6 - Connector
  - ◆ for speedometer
- 7 - Securing bolt
- 8 - Securing bolt
- 9 - Voltage stabiliser
  - ◆ Checking -> Page 80-22
  - ◆ Removing and installing -> Page 80-73
- 10 - Heat sink

90-56

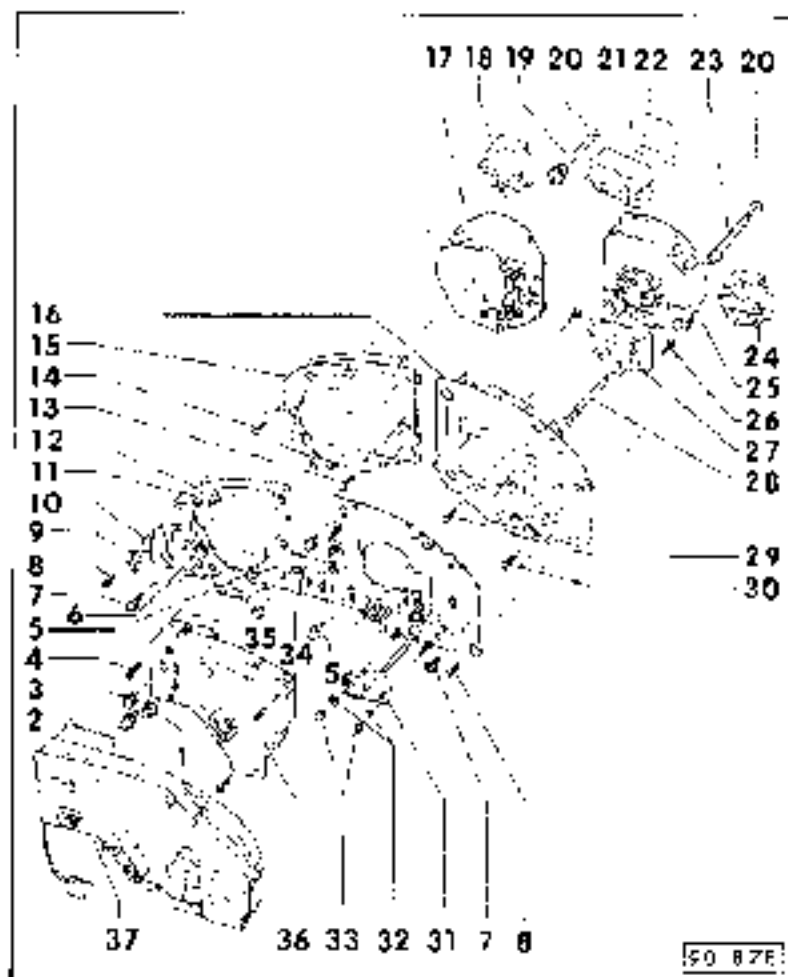

- 11 - Printed circuit board
  - ◆ Assignment of multi-pin connectors -> Page 90-13 onwards
  - ◆ Removing and installing -> Page 90-23
  - ◆ Removing and attaching multi-pin connector => Page 90-18
  - ◆ Repairing multi-pin connector -> Page 90-20
- 12 - Securing bolt
- 13 - Securing bolt
  - ◆ For speedometer
- 14 - Securing bolt
  - ◆ For speedometer base plate

90-57

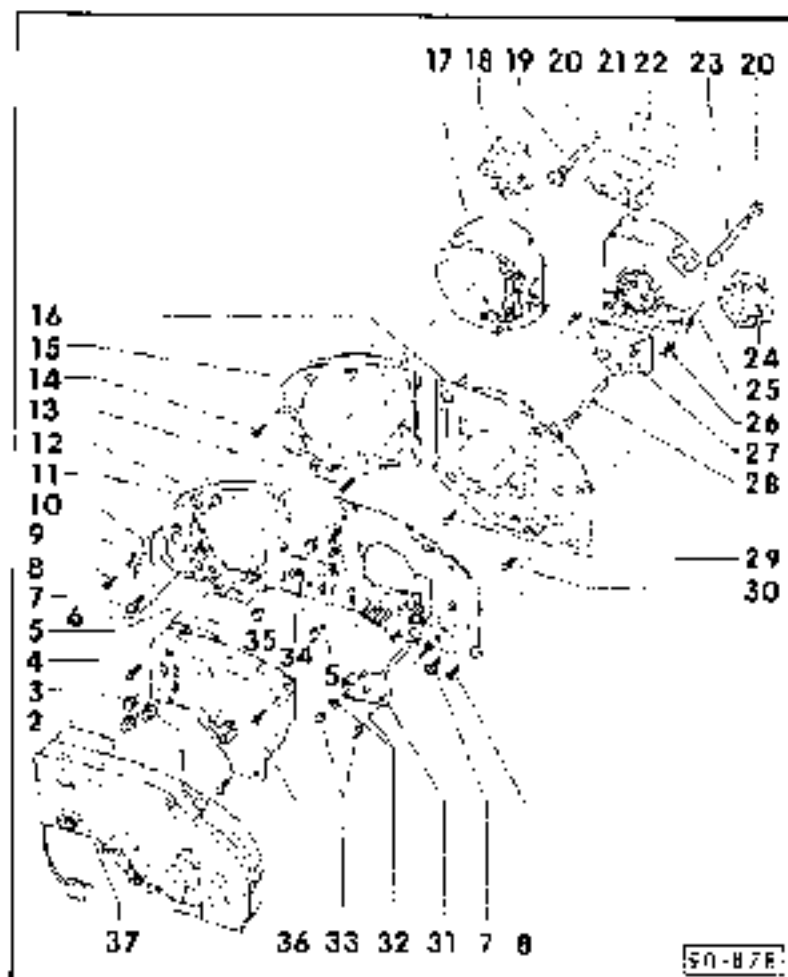

- 15 - Mounting plate
  - ◆ For speedometer
- 16 - Mounting plate
  - ◆ For rev counter
- 17 - Speedometer
  - ◆ Checking speedometer sensor -> Page 90-37.
  - ◆ Removing and installing -> Page 90-50
- 18 - Fuel gauge
  - ◆ Checking -> Page 90-24
  - ◆ Removing and installing -> Page 90-59
- 19 - Adjusting screw
  - ◆ For fuel gauge
- 20 - Felt ring

90-58



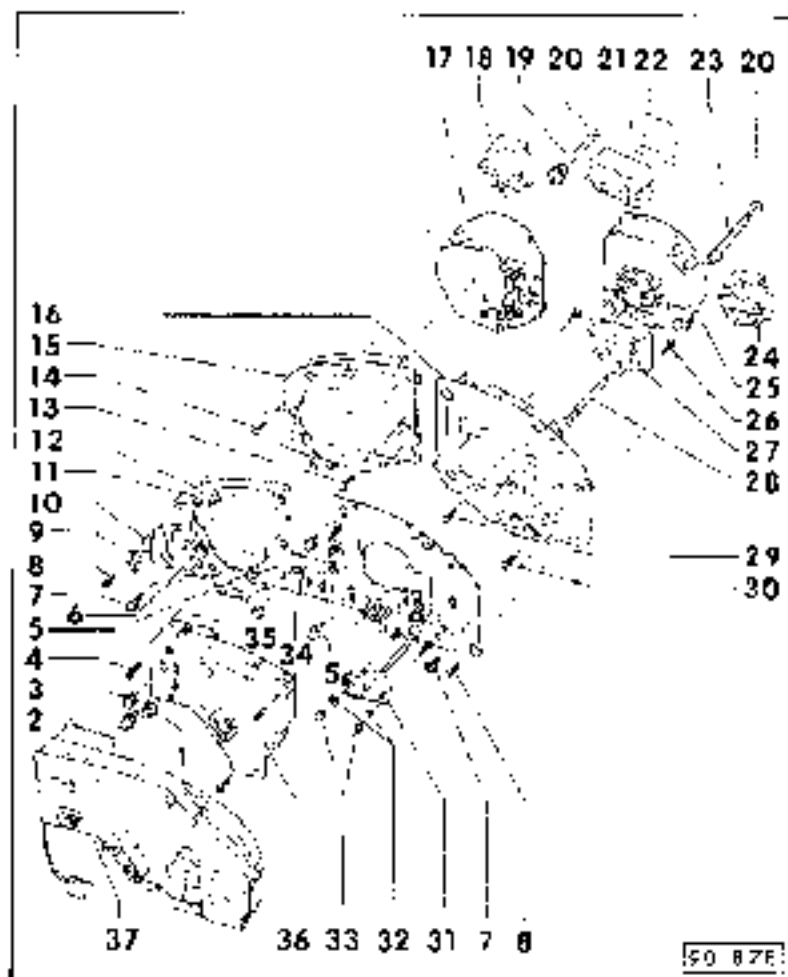

- 21 - Light guide  
◆ For dash panel insert housing
- 22 - Symbol panel  
◆ For indicator/warning lamps
- 23 - Rotating pin  
◆ For dash panel insert lighting; auto-check system button controller
- 24 - Coolant temperature gauge:  
◆ Inserted into front surround  
◆ Checking:  
◆ Vehicles with coolant temperature control switch (overheating) - F14 and coolant temperature gauge sensor G2  
-> Page 50-50

90-59

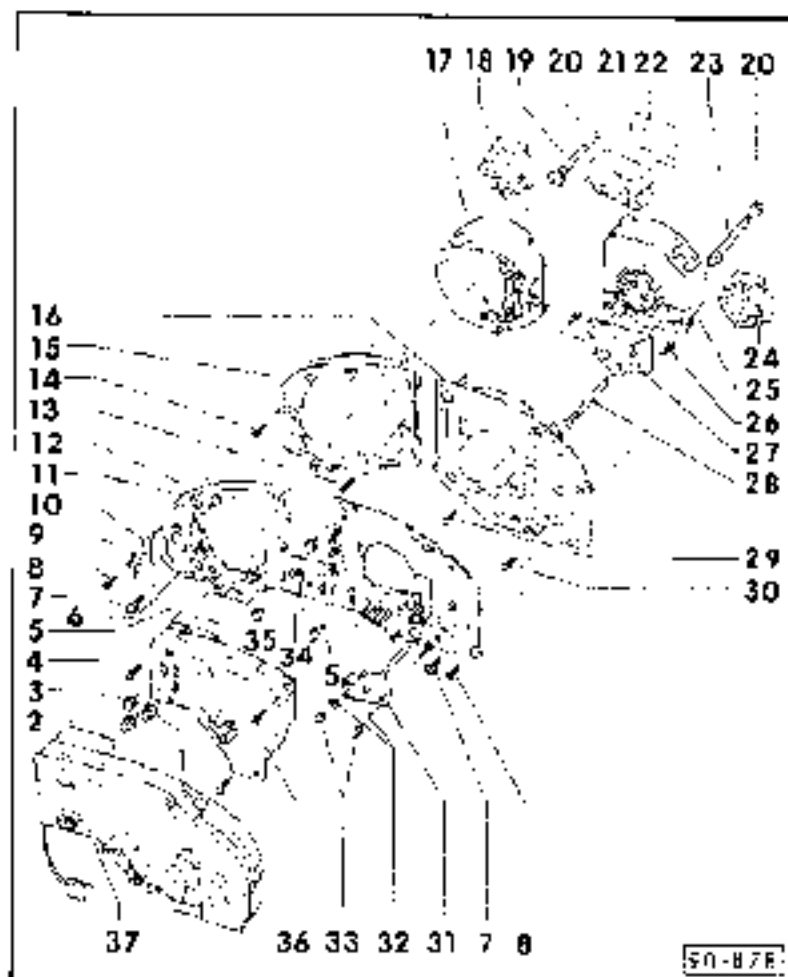

- ◆ Vehicles with electronic thermo switch F76 -> Page 50-33
- ◆ Removing and installing -> Page 50-60
- 25 - Rev. counter  
◆ Checking engine speed signal => Page 50-51  
◆ Removing and installing -> Page 50-57
- 26 - Securing bolt  
◆ For digital clock
- 27 - Digital clock  
◆ Removing and installing -> Page 50-71
- 28 - Adjuster  
◆ For digital clock

90-60

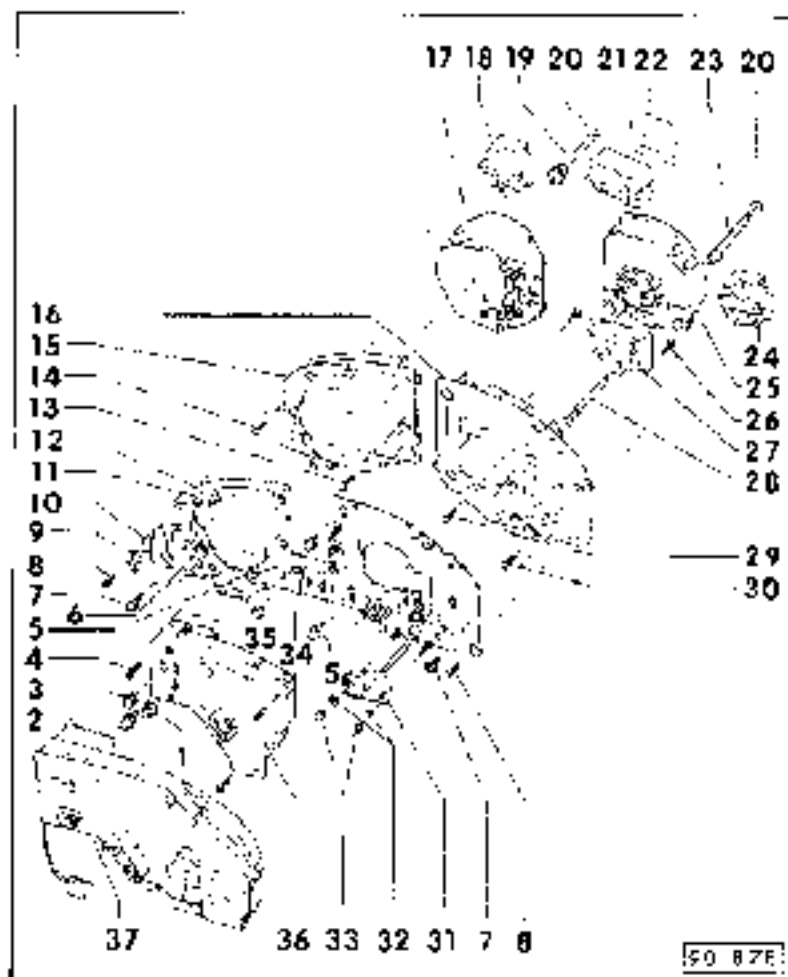

- 29 - Securing bolt
  - ◆ For rev counter
- 30 - Securing bolt
  - ◆ For rev counter base plate
- 31 - Controller
  - ◆ For dash panel insert, switch and instrument lighting
  - ◆ Removing and installing - > Page 90-71
- 32 - Washers
- 33 - hexagon nuts
- 34 - Turn signal indicator lamp
- 35 - Warning and indicator lamps
  - ◆ Assignment - > Page 80-9

90-61

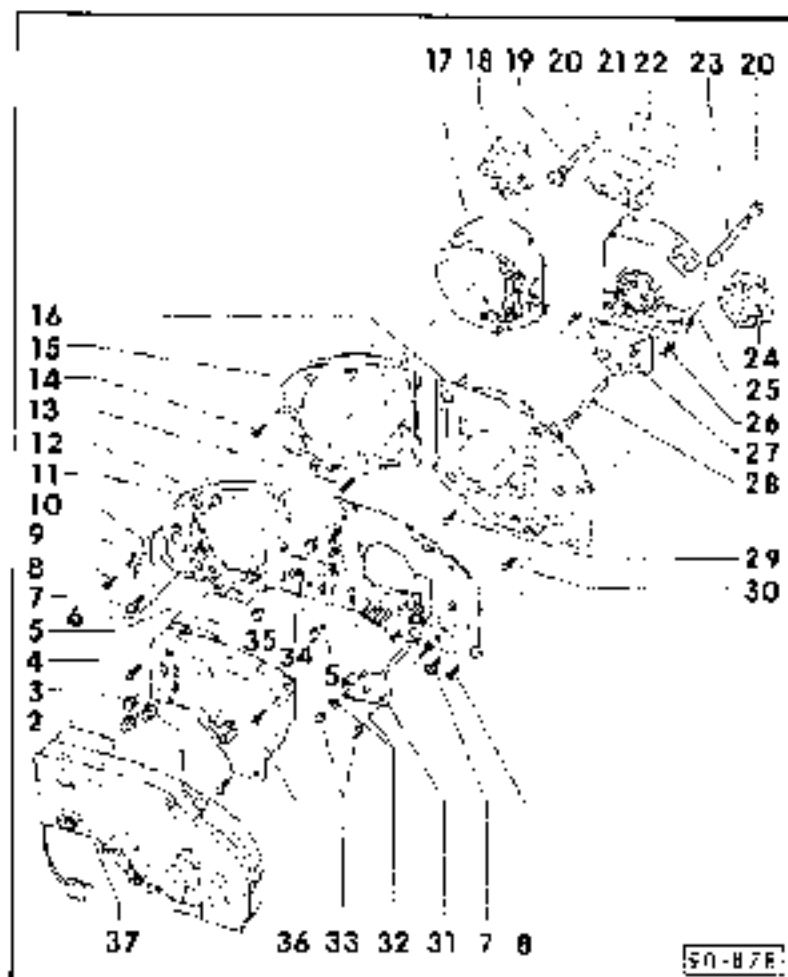

- 36 - Display unit
  - ◆ For mini-check system
  - ◆ checking
  - > "Current Flow Diagrams, Electrical Fault Finding and Fitting Locations" binder
  - ◆ Removing and installing - > Page 90-72
- 37 - Display unit
  - ◆ for auto-check system/on-board computer
  - ◆ checking
  - > "Current Flow Diagrams, Electrical Fault Finding and Fitting Locations" binder
  - ◆ Removing and installing - > Page 90-72

90-62

## Removing and installing Nippon Seiki printed circuit board

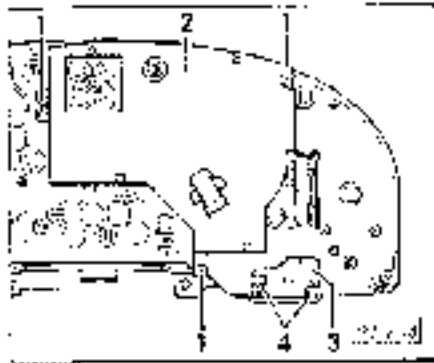

- ◀ - Unscrew hexagon nut -4- with washers and remove highness control -3- for dash panel inset lighting, switches and instruments.
- Release fastening screws -1- and remove display unit for mini-check system-2-.

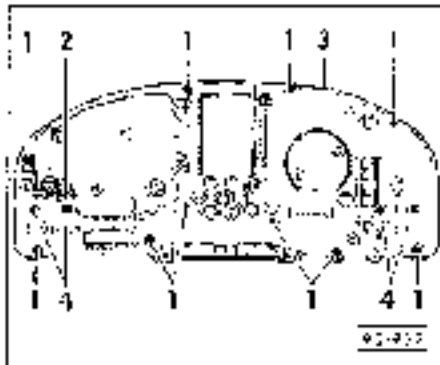

- ◀ - Remove fastening screws 1 and 4
- Detach connector -2- for speedometer.
- Carefully remove printed circuit board 3

### *Note:*

*Remove carefully to avoid breakage!*

90-63

## Removing and installing Nippon Seiki front surround

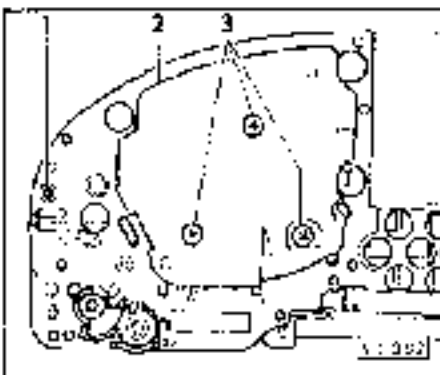

- ◀ - Removing printed circuit board -> Page 90-63
- Remove fastening screw -1- for speedometer base plate -2-.
- Remove speedometer base plate and speedometer

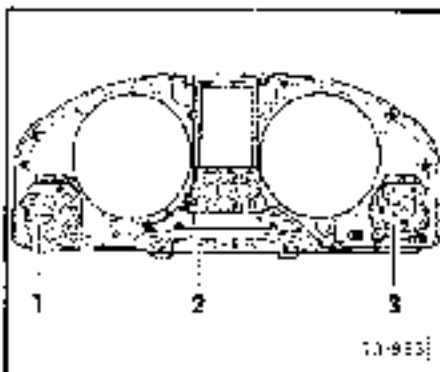

- ◀ - Remove fuel gauge -1- from front surround -2-.

90-64

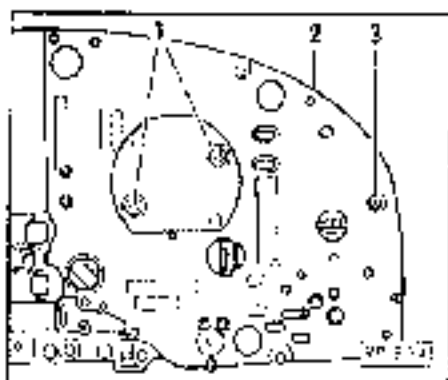

- ◄ - Remove fastening screw -3- for rev counter base plate -2-.  
Remove rev counter base plate and rev counter

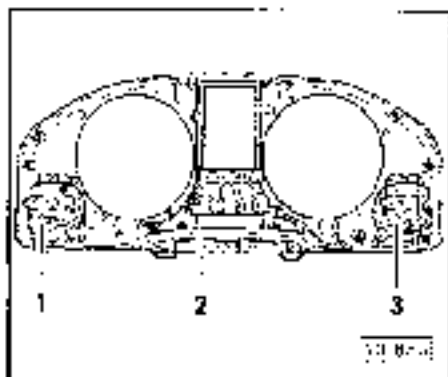

- ◄ Remove coolant temperature gauge -3- from front surround -2-.

— 90-65 —

#### Removing and installing Nippon Seiki speedometer

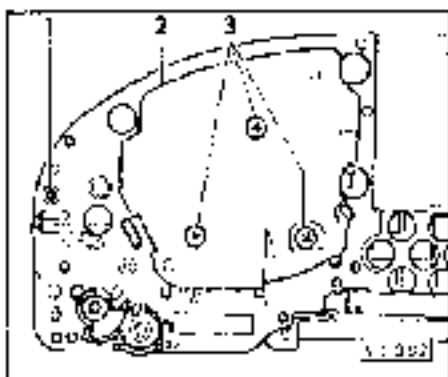

- Removing printed circuit board -> Page 90-63
- ◄ - Remove fastening screws -1- and -3- for speedometer base plate -2-.
- Remove speedometer base plate

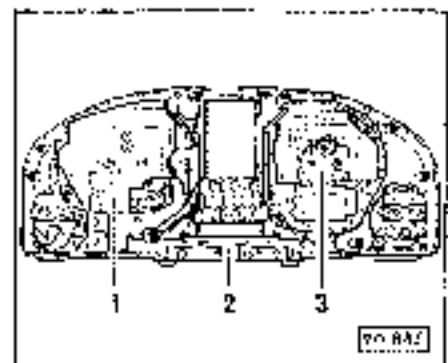

- ◄ - Remove speedometer -1- from front surround -2-.

— 90 66 —

## Removing and installing Nippon Seiki rev counter

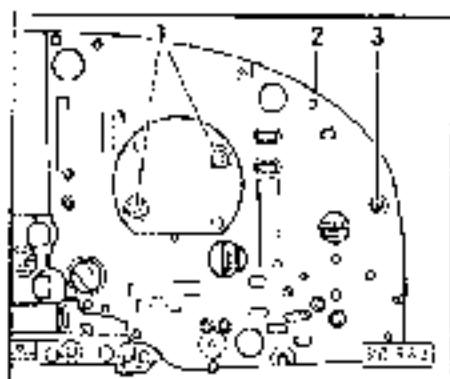

- Removing printed circuit board => Page 90-63
- Remove fastening screws -1- and -3- for rev counter base plate -2-.
- Remove rev counter base plate

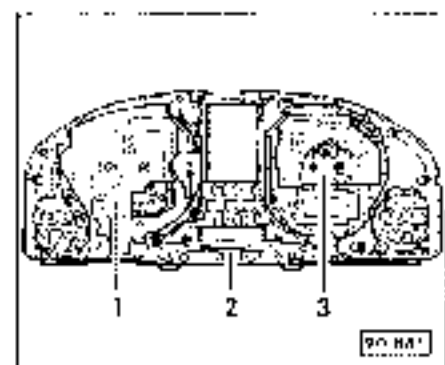

- Remove rev counter -3- from front surround -2-.

90-67

## Removing and installing Nippon Seiki fuel gauge

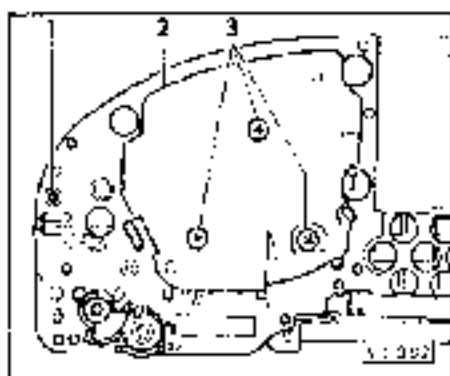

- Removing printed circuit board => Page 90-63
- Remove fastening screw -1- for speedometer base plate -2-.
- Remove speedometer base plate and speedometer

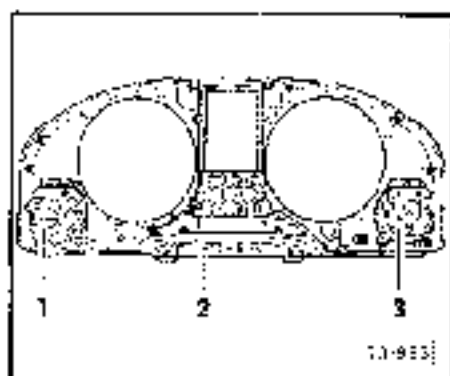

- Remove fuel gauge -1- from front surround -2-.

90-68

## Removing and installing Nippon Seiki coolant temperature gauge

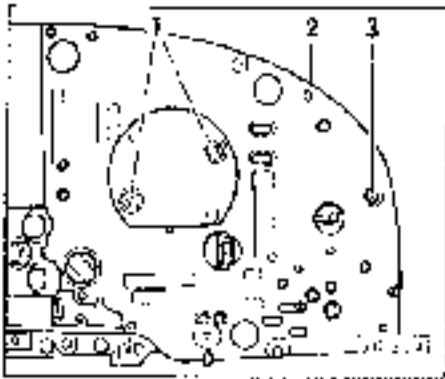

- Removing printed circuit board => Page 90-63
- ◀ Remove fastening screws -3- for rev counter base plate -2-
- Remove rev counter base plate and rev counter.

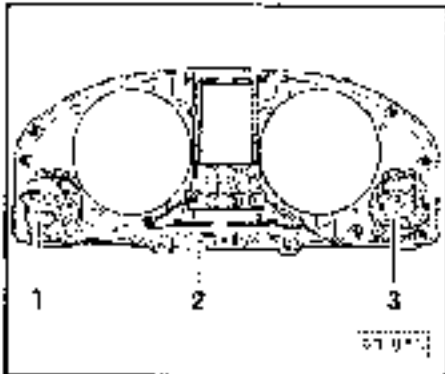

- ◀ - Remove coolant temperature gauge -3- from front surround -2-.

90-69

## Removing and installing Nippon Seiki digital clock

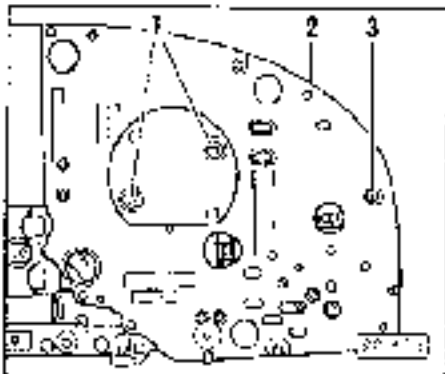

- Removing printed circuit board => Page 90-63
- ◀ - Remove fastening screws -1- and -3- for rev counter base plate -2-.
- Remove rev counter base plate

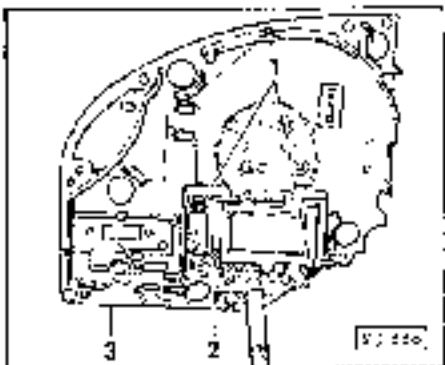

- ◀ - Unscrew fastening screws -1- for digital clock.
- Remove digital clock -2- from base plate -3- for rev counter.

90-70

## Removing and installing brightness control for dash panel insert lighting, switches and instruments

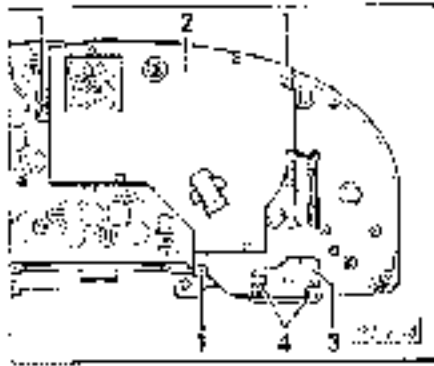

- Remove hexagon nuts -4- with washers.
- Remove brightness control for dash panel insert lighting, switches and instruments -3-.

### Note:

When replacing the dash panel insert lighting control unit, ensure that the flat surface of the adjusting arbor fits exactly into the adjusting pin. If necessary, remove adjusting pin and install together with the lighting control unit.

## Removing and installing pedestal lamps

Lamp assignments → as of Page 80/9

- Give cap-type lamps 1/4 one quarter of a turn 180° anticlockwise and remove.

90-71

## Removing and installing display unit for mini-check system.

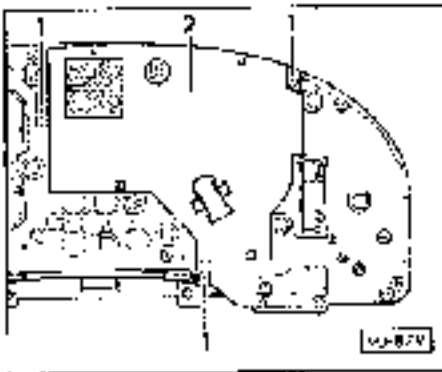

- Remove fastening screws -1-.
- Remove display unit for mini-check system.

## Removing and installing display unit for auto-check system/on-board computer.

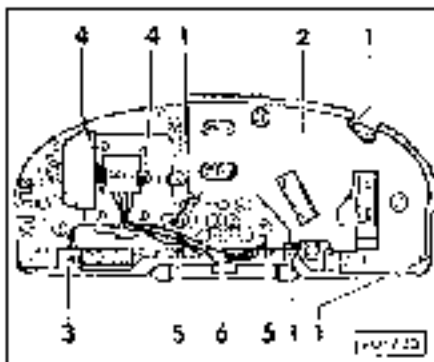

- Remove fastening screws -1-.
- Unclip adjuster for range calibration -3- (with on board computer system only).
- Remove display unit for auto check system/on board computer -2-.

90-72

## Removing and installing voltage stabilizer

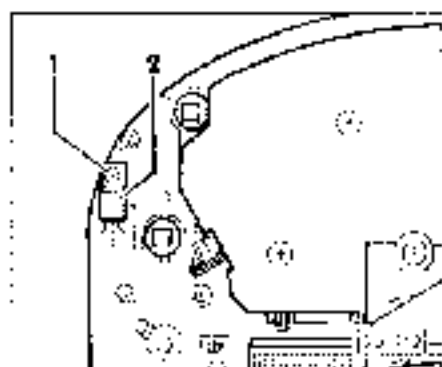

- ◀ - Loosen fastening screw -1- and carefully remove voltage stabilizer.

## Removing and installing gear indicator

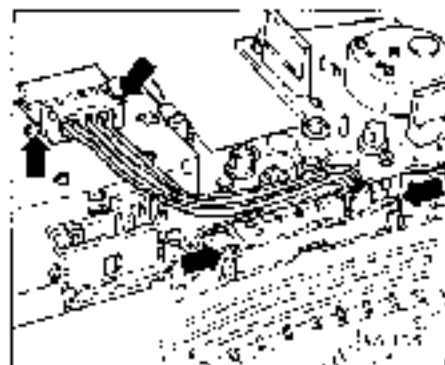

- Removing dash panel insert -> Page 80 B
- ◀ - Disconnect 5-pin connector for gear indicator.
- Unscrew fastening screws for plug-in coupling and gear indicator-arrows- on dash panel insert and remove gear indicator.

### Note:

When replacing the dash panel insert, break out the dummy cover on the warning lamp symbol panel.

90-73

## 5-pin connector behind dash panel insert for gear indicator

### Signal assignment and checking

Removing dash panel insert -> Page 80 B Leave multi pin connectors attached.

- Remove connector for gear indicator.

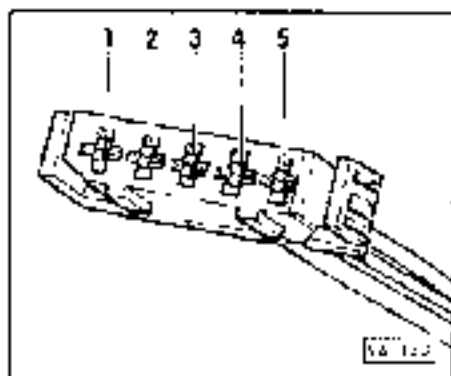

- ◀ **Cavity 1. Gear signals**
- Use hand-held multimeter V A G 1526 (measuring range: DCI) to measure against earth
- Switch ignition on.
  - Specifications.

Selector lever position	Specified value
P	approx. 6.0 V.
R	approx. 4.2 V.
N	approx. 3.4 V.
D	approx. 2.8 V.
3	approx. 2.5 V.
2	approx. 2.2 V.
1	approx. 2.0 V.

90 74



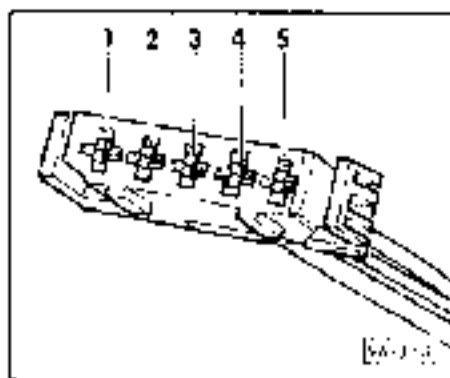

◀ **Cavity 2. earth**

Use hand-held multimeter V.A.G 1526 (measuring range: DC) to measure against terminal 30.

- Specified value: Battery voltage

**Cavity 3. Lighting terminal 58d**

- Use hand-held multimeter V.A.G 1526 (measuring range: DC) to measure against earth

- Switch side lights on
  - Specified value: Depending on setting of brightness control for dash panel insert lighting

2.75 V ... approx. battery voltage

**Cavity 4. Positive terminal 15a**

Switch ignition on.

- Use hand-held multimeter V.A.G 1526 (measuring range: DC) to measure against earth

- Specified value: Battery voltage

**Cavity 5. Unallocated**

**Removing and installing outside temperature gauge**

- Removing dash panel insert -> Page 90-9
- Disconnect 2-pin outside temperature gauge connector
- Unscrew attachment screws for plug-in coupling and outside temperature gauge-arrows- on dash panel insert and remove outside temperature gauge.

**Note:**

*When replacing the dash panel insert, break out the dummy cover on the warning lamp symbol carrier.*

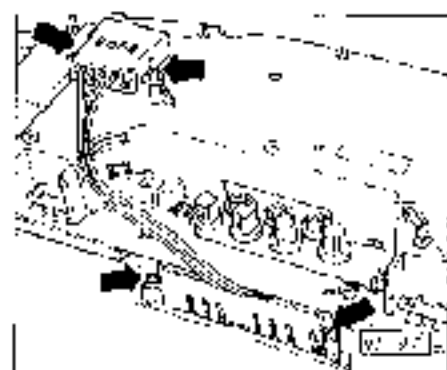

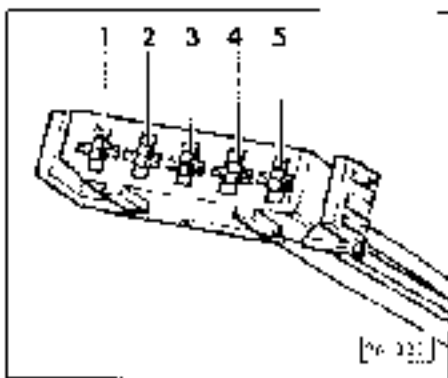

### 5-pin connector behind dash panel insert for outside temperature gauge

#### Signal assignment and checking

Removing dash panel insert -> Page 90-78

- Remove outside temperature gauge connector.

#### Cavity 1. Speed signal

- Use hand-held multimeter V A G 1526 (measuring range: AC) measure against earth

- Specified value: approx. 4 mV at inching speed

#### Cavity 2. temperature sensor

- Use hand-held multimeter V A G 1526 (measuring range: resistance) measure against earth

- Specified value: U-Value depending on outside temperature -> diagram

#### Cavity 3. Earth

- Use hand-held multimeter V A G 1526 (measuring range: DC) to measure against terminal 30.

- Specified value: Battery voltage

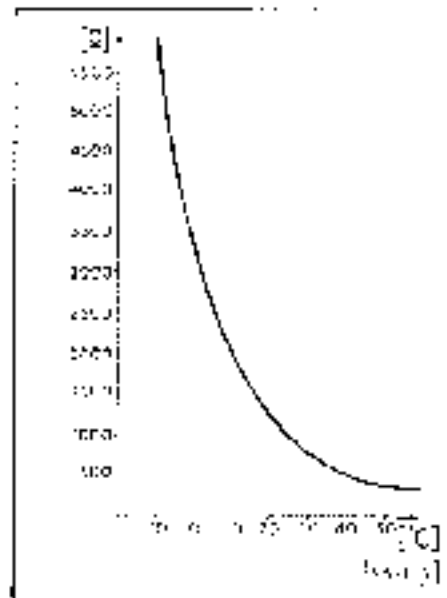

90-77

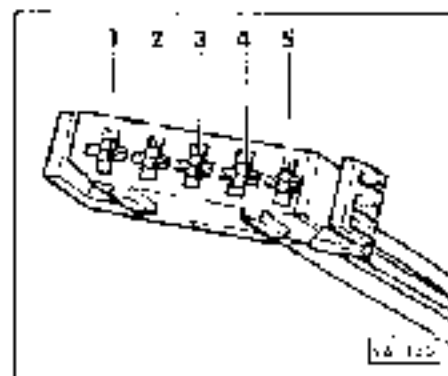

#### Cavity 4. Lighting terminal 58d

- Switch side lights on
- Use hand-held multimeter V.A.G 1526 (measuring range: DC) to measure against earth

- Specified value: Depending on setting of brightness control for dash panel insert lighting  
2.75 V ... approx. battery voltage

#### Cavity 5. Positive terminal 15a

- Switch ignition on.
- Use hand-held multimeter V A G 1526 (measuring range: DC) to measure against earth

- Specified value: Battery voltage

90-78

## Checking outside temperature gauge

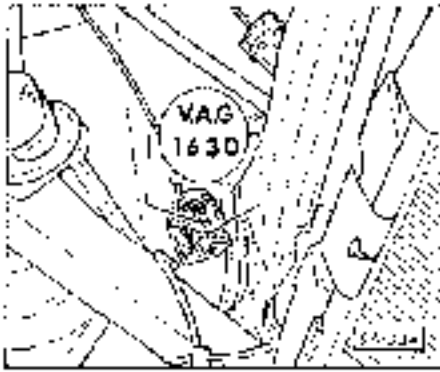

- ◀ - Connect digital potentiometer V.A.G 1630 to detached outside temperature gauge sensor (near left headlight).  
Switch ignition on.
- Adjust V.A.G 1630 digital potentiometer as follows:

Setting	Specified value
5000	-10 °C
3200	0 °C
1200	20 °C
500	40 °C

- If specified values are not attained, check signals at detached 5-pin connector behind dash panel insert -> Page 90-77 separate check digital voltage current flow direction on replace outside temperature gauge.

— 90-79 —

## Removing and installing outside temperature gauge sensor

- Remove bumper
  - > General Body Repairs; Repair Group 63; Front bumper; Front bumper - exploded view ->
- Detach connector near left headlight.
- Unclip outside temperature gauge sensor behind bumper.
- To install, press outside temperature gauge sensor into holder until catches engage.

— 90 80 —

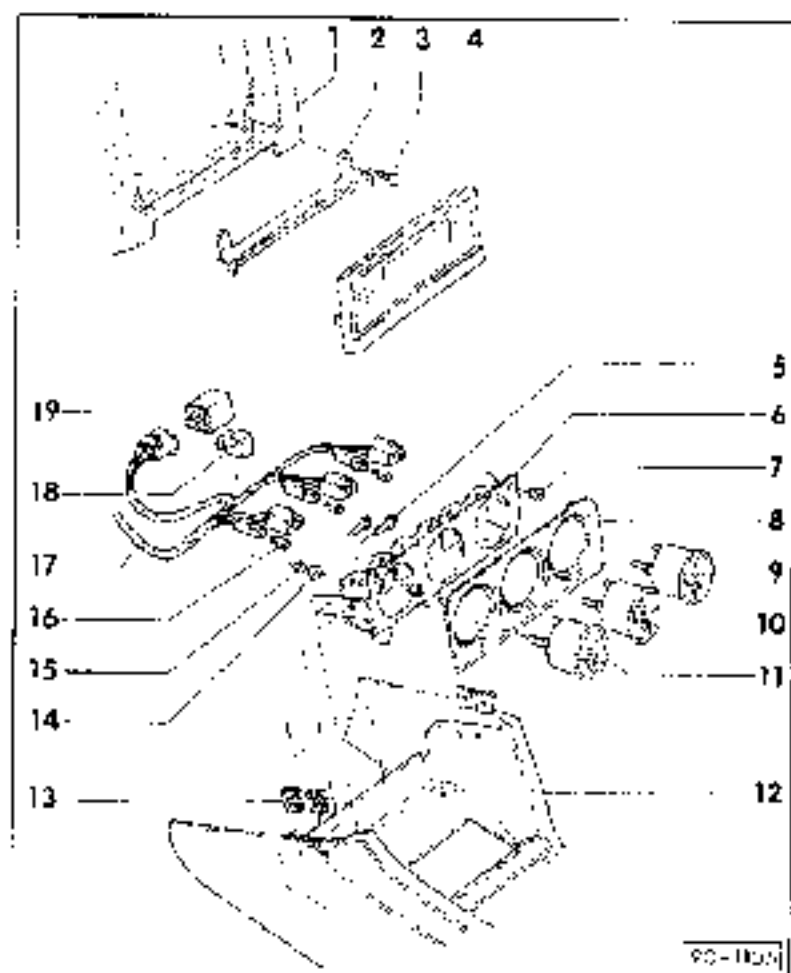

## Additional instruments

### Troubleshooting

-> "Current Flow Diagrams, Electrical Fault Finding and Fitting Locations" Index

- Removing front centre console

-> Body Assembly Work: Repair Group 70: Dash Panel; Removing and installing the front centre console ->

### Servicing additional instruments > 01.92

1 - Centre section of instrument panel

2 - Locking piece

3 - Bolt, 2 Nm

◆ 2x

◆ Only accessible after prising off trim

90-81

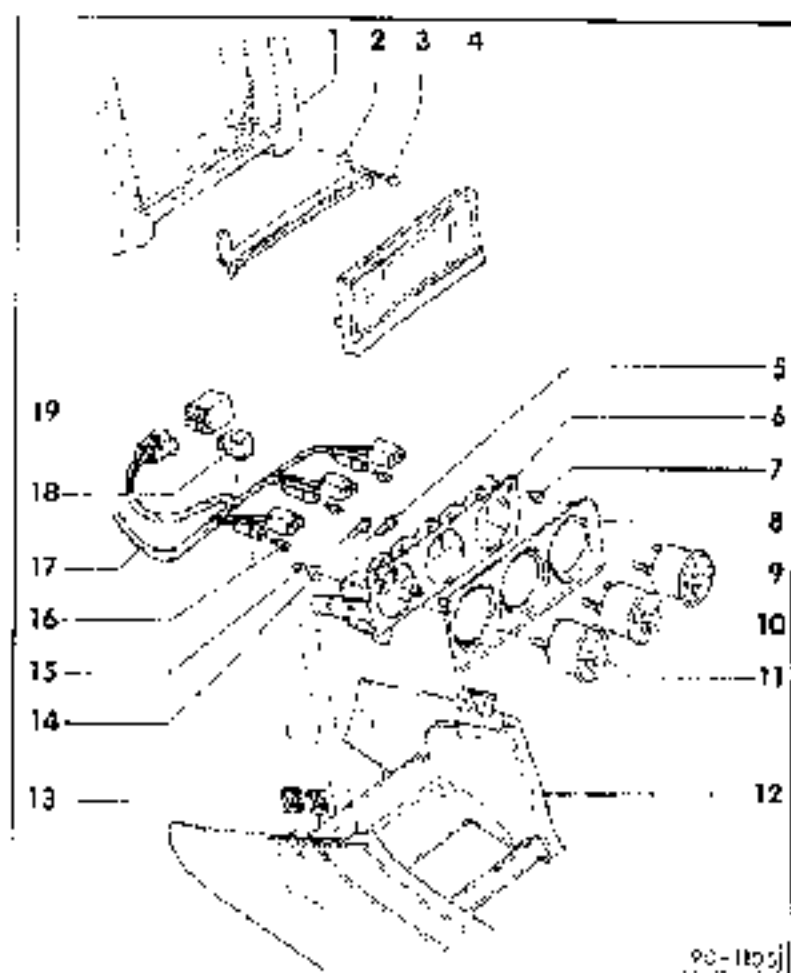

4 - Trim

◆ Vehicles with air conditioner. Prise off carefully using screwdriver.

◆ Vehicles with no AC -> Item 4, Page 80-82

5 - Hexagon bolt 5 Nm

◆ 4x

6 - Angle bracket

7 - Grommet

◆ 2x

8 - Trim

9 - Oil temperature gauge

◆ Checking => Page 80-82

◆ Removal.

- Remove the connector.

- Twist and pull off lamp socket

90-82

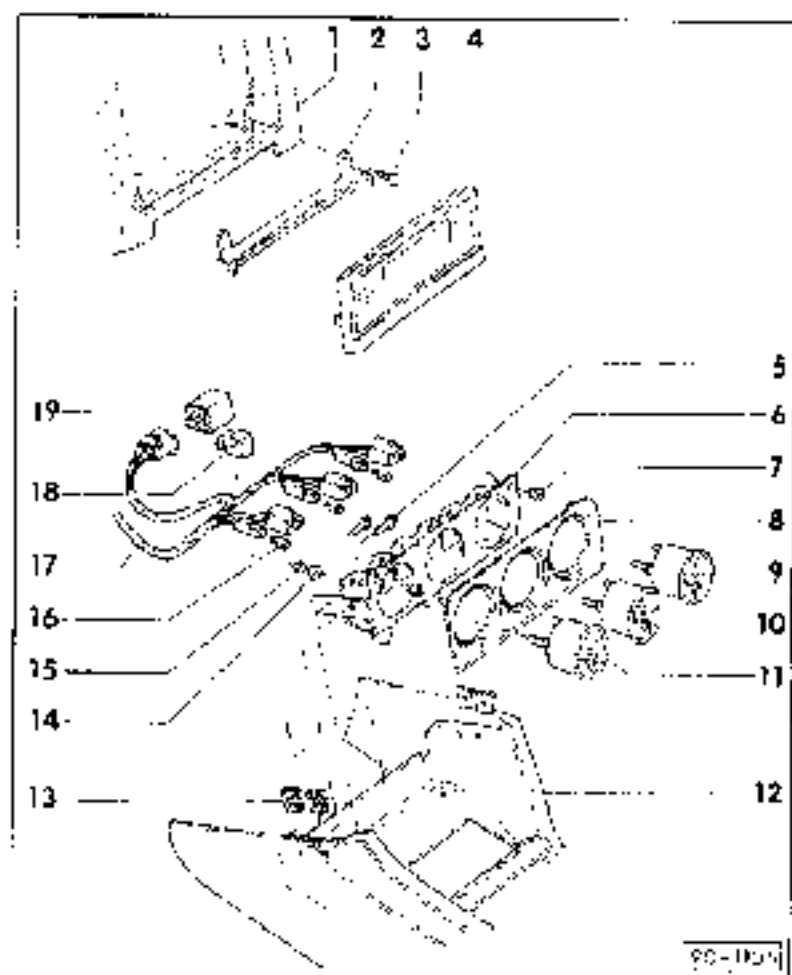

- Remove hexagon nuts - item 15- and pull out indicator.

- 10 - Oil pressure gauge
  - ◆ Checking -> Page 90-83
  - ◆ Removal as for Item 9-
- 11 - Voltmeter
  - ◆ Checking => Page 90-84
  - ◆ Removal as for Item 9-
- 12 - Centre console
- 13 - Snap nut
  - ◆ 4x
- 14 - Washer
  - ◆ 6x

90-83

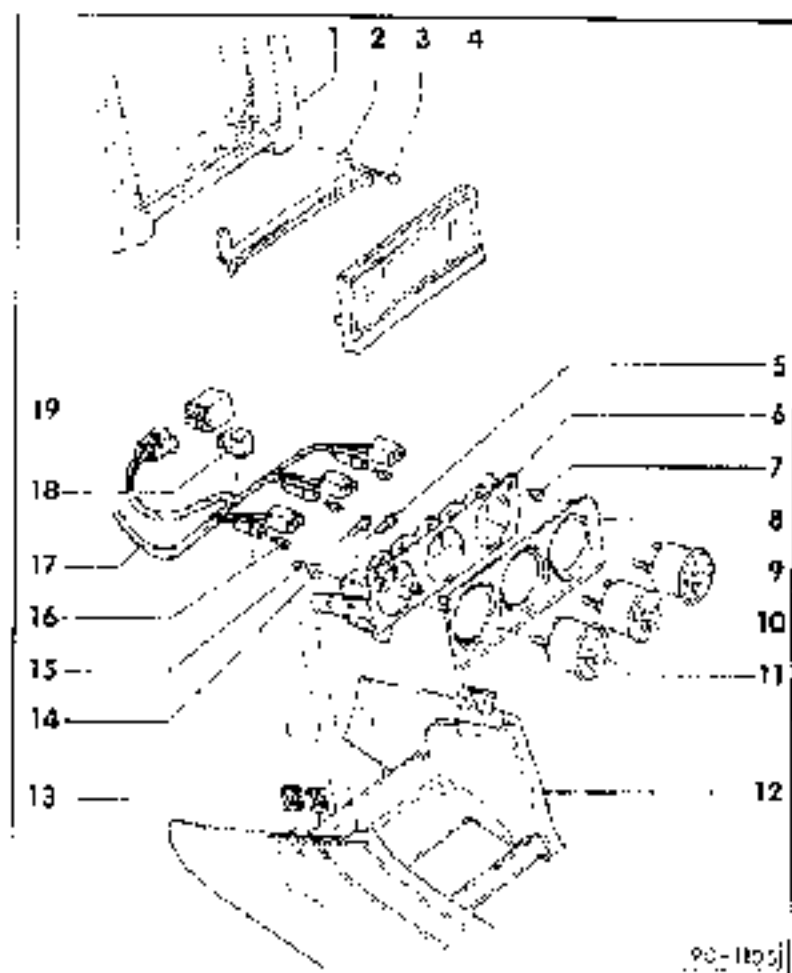

- 15 - Hexagon nut
  - ◆ 6x
- 16 - Lighting for additional instruments
  - ◆ 1.2 W (3x)
- 17 - Wiring loom
  - ◆ Routing of wiring and cavity assignments
  - > "Current Flow Diagrams, Electrical Fault Finding and Fitting Locations" binder
- 18 - Retaining clip
- 19 - Amplifier for instrument lighting
  - ◆ Clipped with retainer to rear of centre console

90-84

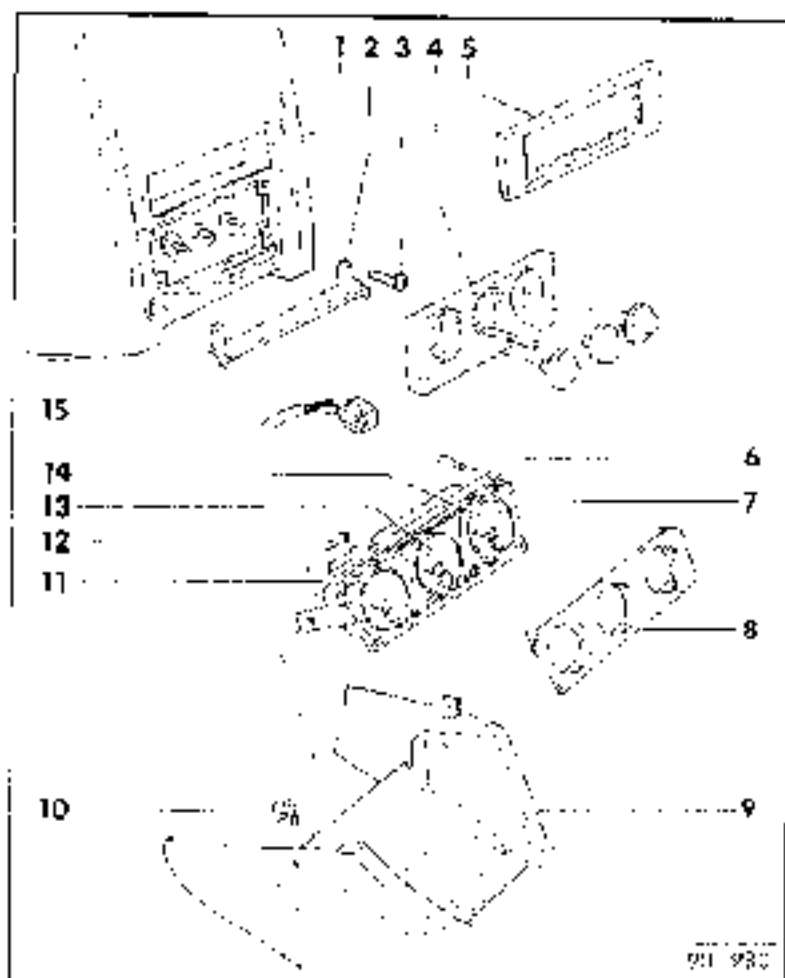

## Servicing additional instruments 02.92 >

### Note:

The indicator instruments 02.92 > are interchangeable with the individual instruments > 01.92.

- 1 - Dash panel
- 2 - Locking piece
- 3 - Bolt, 2 Nm
  - ◆ 2x
  - ◆ Only accessible after prising off trim
- 4 - Trim
  - ◆ Unscrew after pulling off rotary knobs

90-85

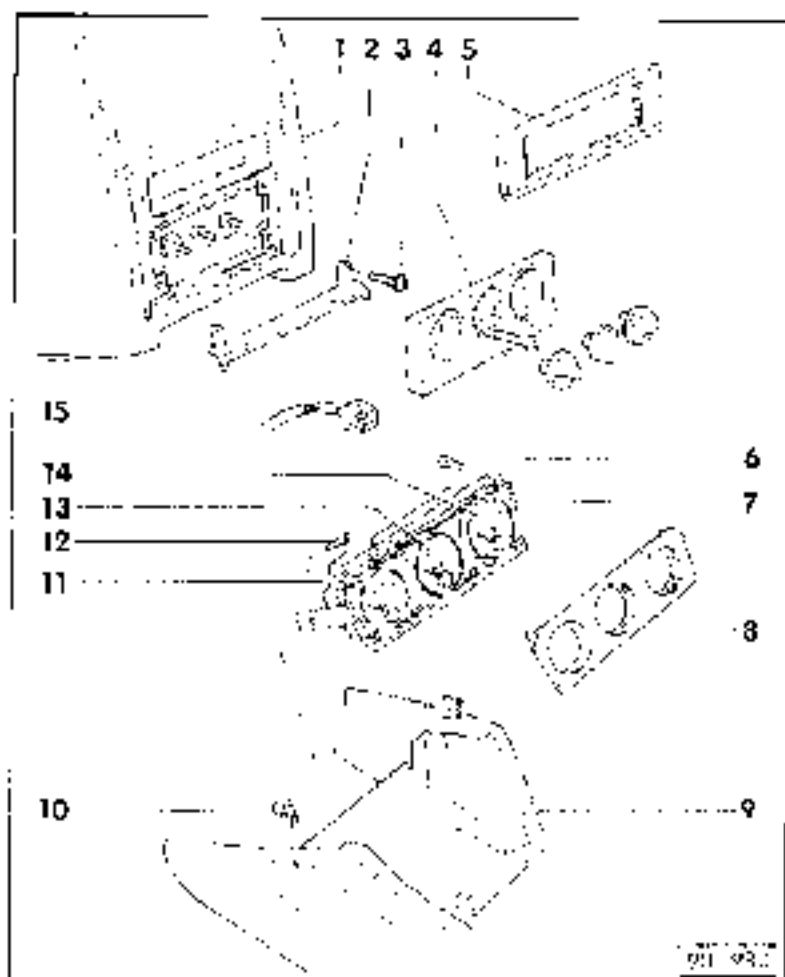

- 5 - Trim
  - ◆ Automatic AC only
  - ◆ Prise off carefully using screwdriver.
- 6 - Bolt, 2 Nm
  - ◆ 6x
- 7 - Housing for additional instruments with transparent cover panel
  - ◆ Removal: Pull off connector and remove hexagon bolts - Item 12.
  - ◆ Connector assignment - > Page 90 89.
- B - Trim
  - ◆ Secured with screws - Item 6-

90 86

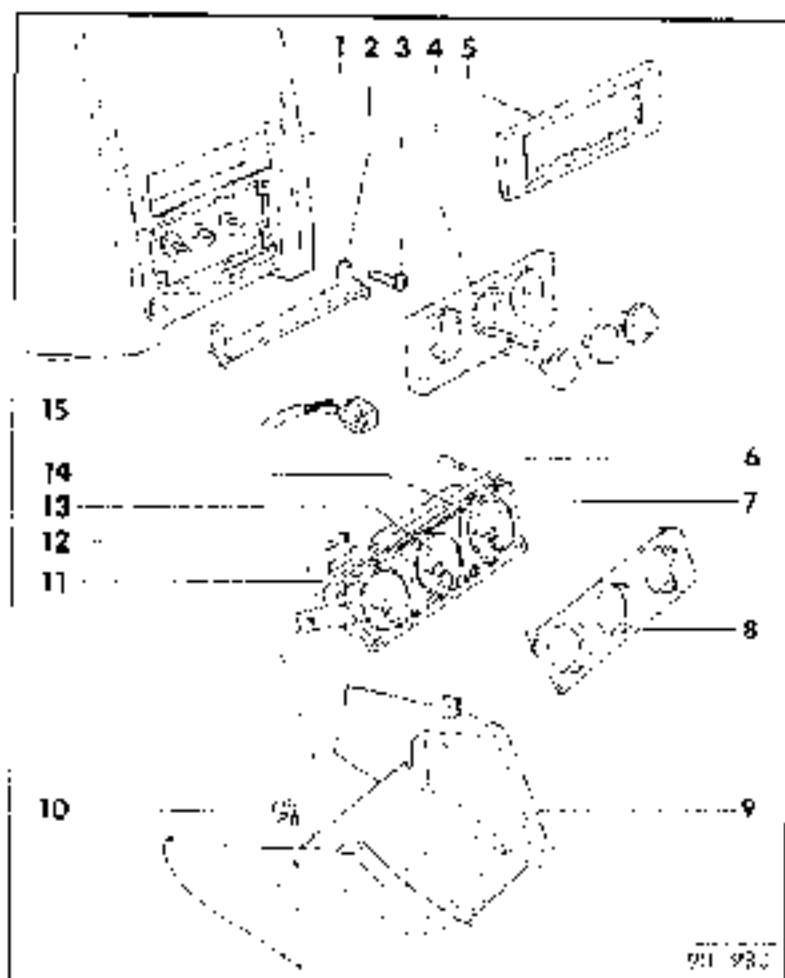

9 - Centre console

10 - Snap nut  
◆ 4x

11 - Oil temperature gauge  
◆ Checking -> Page 90-83  
◆ Before removing, unscrew hexagon nut with washer -> Page 90-81

12 - Hexagon bolt  
◆ 2x

13 - Oil pressure gauge  
◆ Checking -> Page 90-82  
◆ Removing and installing -> Page 90-81

90-87

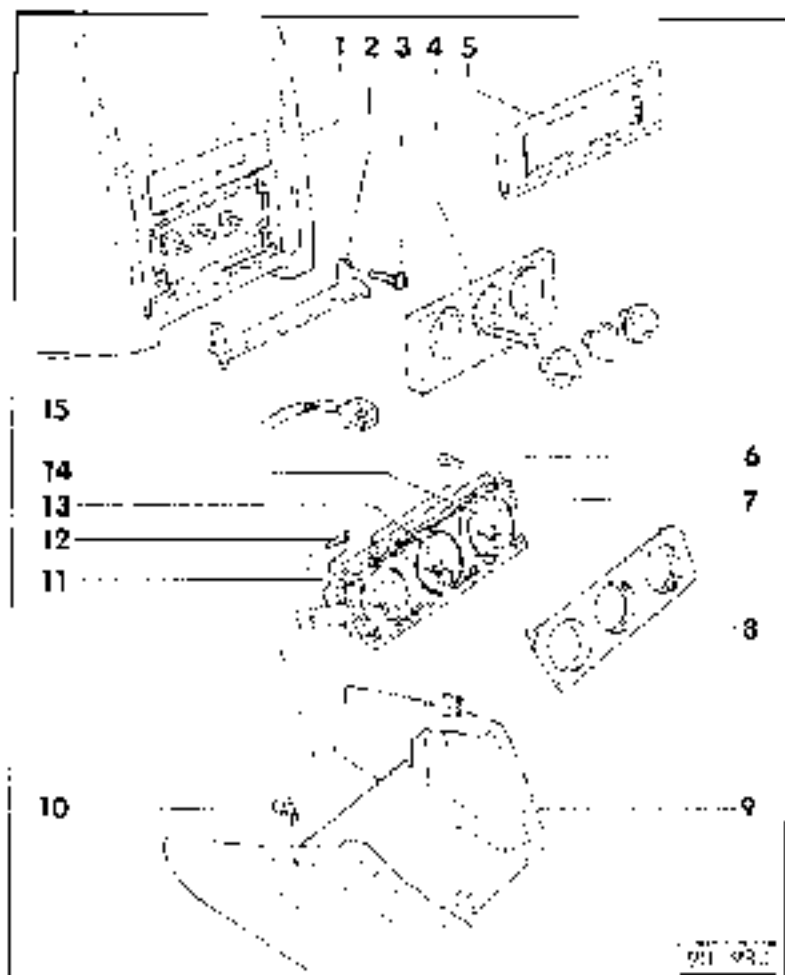

14 - Voltmeter  
◆ Checking -> Page 90-84  
◆ Removing and installing -> Page 90-81

15 - Wiring loom  
◆ Connector assignment -> Page 90-88.

90-88

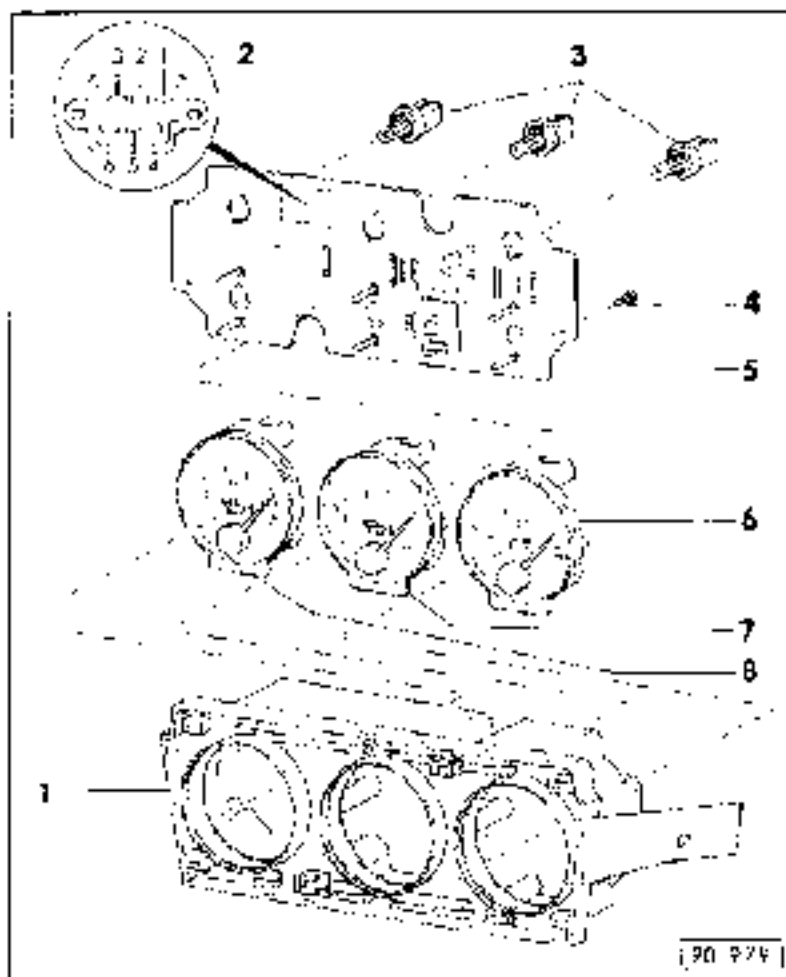

### Removing and installing components of additional instruments 02.92 >

- 1 - Housing with transparent cover panel
  - ◆ Ultrasonically welded
- 2 - Multi-pin connector
  - ◆ Use appropriate current flow diagram.
  - ◆ Contact assignment
    - 1 - Variable positive from brightness control for dash panel inset lighting to amplifier for additional instrument lighting
    - 2 - Negative from oil pressure gauge sensor

90-89

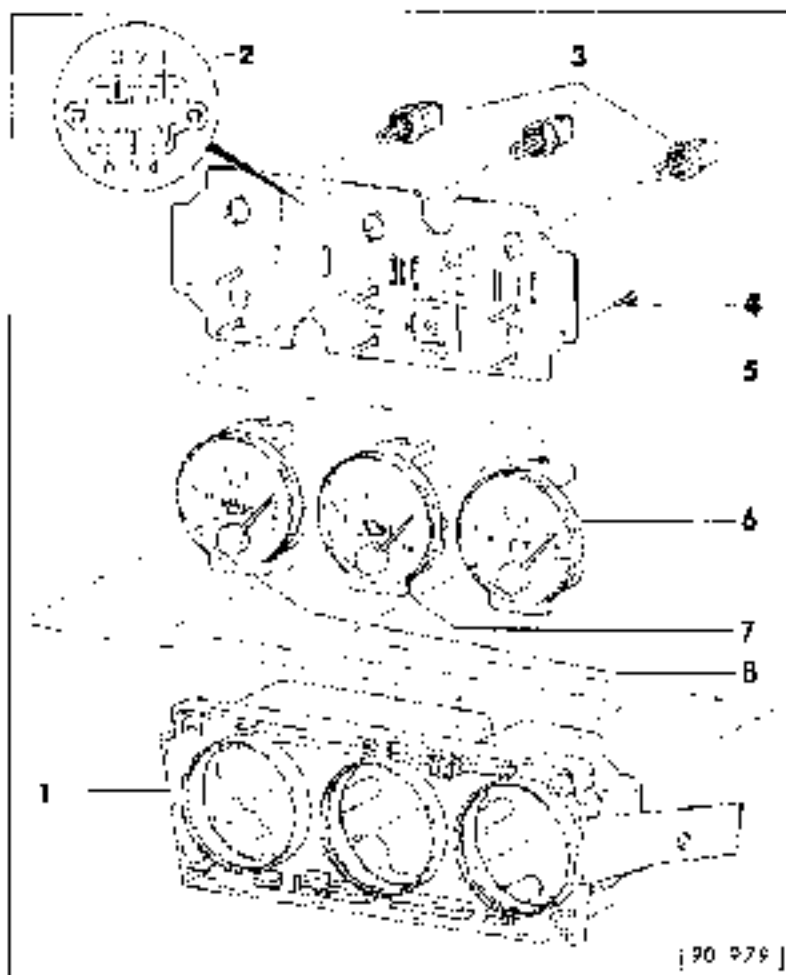

- 3 - Lighting for additional instruments
  - ◆ 1.2 W (3x)
- 4 - Fastening screw
  - ◆ For printed circuit board
  - ◆ 1x

90 90



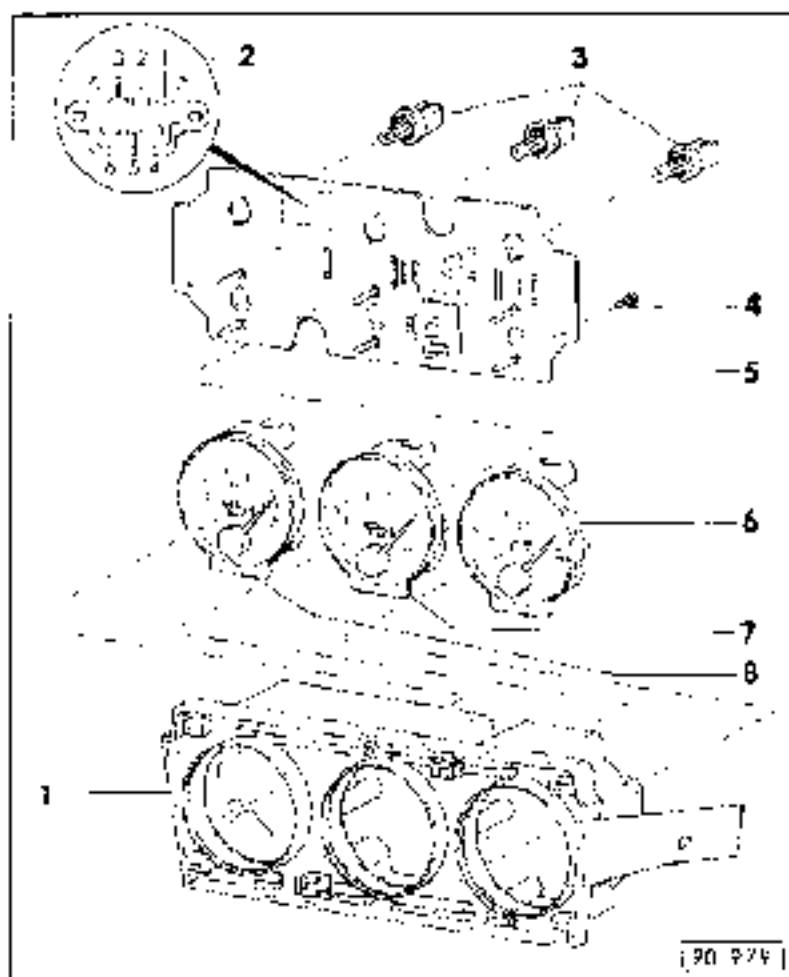

5 - Printed circuit board

6 Voltmeter

♦ Only replace in conjunction with printed circuit board - item 5-

7 - Oil pressure gauge

8 - Oil temperature gauge

90-91

### Checking oil pressure gauge

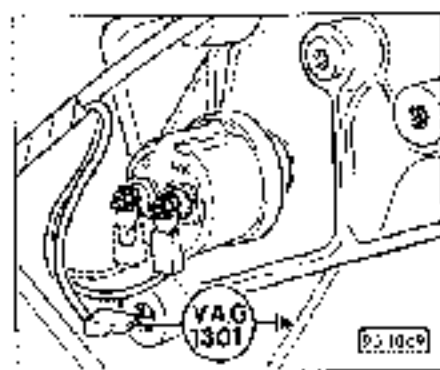

- Remove noise insulator

- Pull connector off oil pressure sensor, terminal -G-

**Note:**

*Illustration shows 5-cyl. engine.*

*Location on 4-cyl. engine: At oil filter housing.*

*Location on 5-cyl. engine: At oil filter housing or on back of engine.*

- Switch ignition on.

Connect tester V.A.G 1301 to plug and earth using auxiliary cable.

Adjust V.A.G 1301 tester as follows:

Setting	Specified value
350	5 bar
150	2 bar
10	0 bar

- If specified value is not attained, locate open circuit using current flow diagram and rectify fault

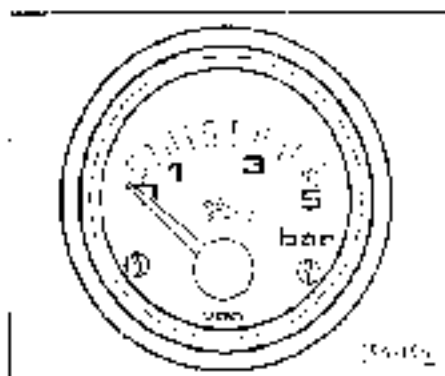

90 92

## Checking oil temperature gauge

- Remove noise insulator
- Unscrew connector from oil temperature sensor (at oil pump).

### Note:

Illustration shows 5-cyl. engine.

Location on 4 cyl. engine: At oil filter housing.

Location on 5-cyl. engine: On end face of engine at oil pump

- Connect test unit V.A.G 1301 to screw connection and earth.
- Switch ignition on.

- Adjust V.A.G 1301 tester as follows:

Setting	Specified value
2F	170 nC
150	130 nC
680	60 nC

- If specified value is not attained, locate open circuit using current flow diagram and rectify fault

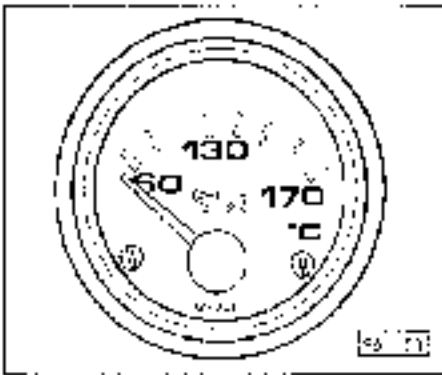
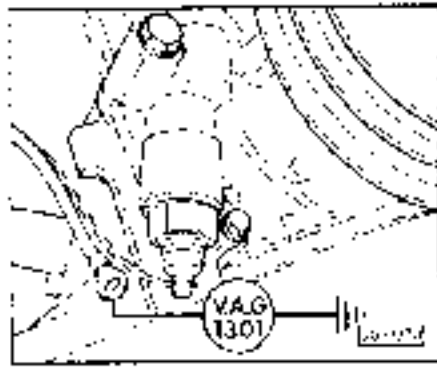

90-93

## Checking voltmeter

- Switch ignition on.
  - Specified value: approx. battery voltage
- If specified value is not attained, locate open circuit using current flow diagram and rectify fault.

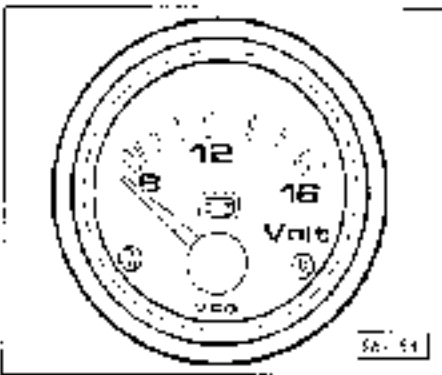

90-94

## Car radio systems

### *Notes:*

- ◆ Disconnect battery earth strap before working on electrical system.
- ◆ If complaints are received, it is vital to be familiar with the functionality and operation of the relevant radio system. Additional information
  - = > Operating instructions for the radio concerned
  - > "Special information" binder; Electric section
- ◆ For retrofitting, repair work and troubleshooting
  - > "Current Flow Diagrams, Electrical Fault Finding and Fitting Locations" binder
    - > Installation instructions
- ◆ Detailed assembly instructions for removing and replacing the trim
  - > General Body Repair
- ◆ Only radio devices and built-in components from the V.A.G. range or original replacement parts should be used. This is the only way to guarantee problem free installation and good reception.

91-1

- ◆ A distinction is made between active and passive loudspeaker systems.
- ◆ The voltage for the radio systems is supplied via a fuse in the fuse box.
- ◆ The anti-theft coding unit for "alpha" and "beta" radios > 05.941 features a fixed code. Operation is only possible using the **U** and **M** keys.

### *Notes on radio retrofitting*

- ◆ The provided connectors for original Audi radio systems should be used for preparing the radio.
- ◆ Radios with other plug connectors must be connected using adapter leads (fitted in glove compartment during radio preparation).
- ◆ When connecting the speed signal (radios with GALA function) care must be taken not to short circuit the signal, since otherwise vehicle malfunctions may occur (e.g. in engine control unit).
- ◆ Connecting the speed signal to other makes of radio can also lead to vehicle malfunctions.

91-2

## Radio systems - general layout

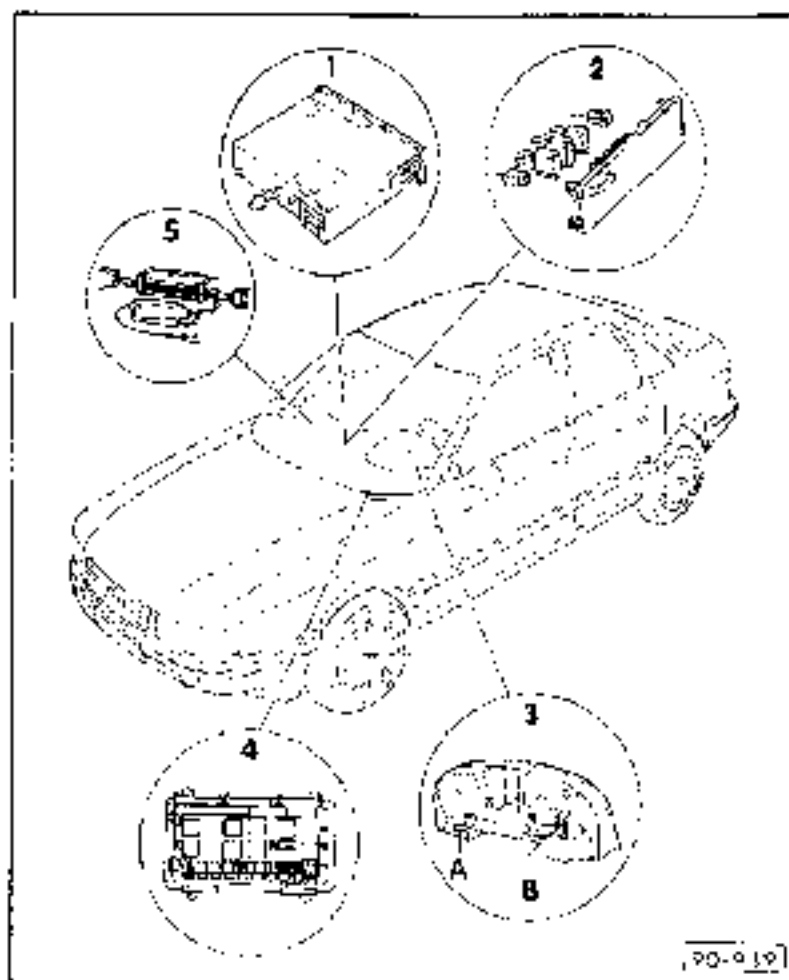

### 1 - Radio -R

- ◆ Installed in centre console
- ◆ Removing and installing - > Page 91-3 and 91-5

### 2 - Radio preparation

- ◆ Not available in Germany
- ◆ Use screwdriver to prise off trim
- ◆ Unclip plug from trim
- ◆ Adapter leads for radio connection (old generation) are provided
- ◆ Only for front and rear passive loudspeakers

91-3

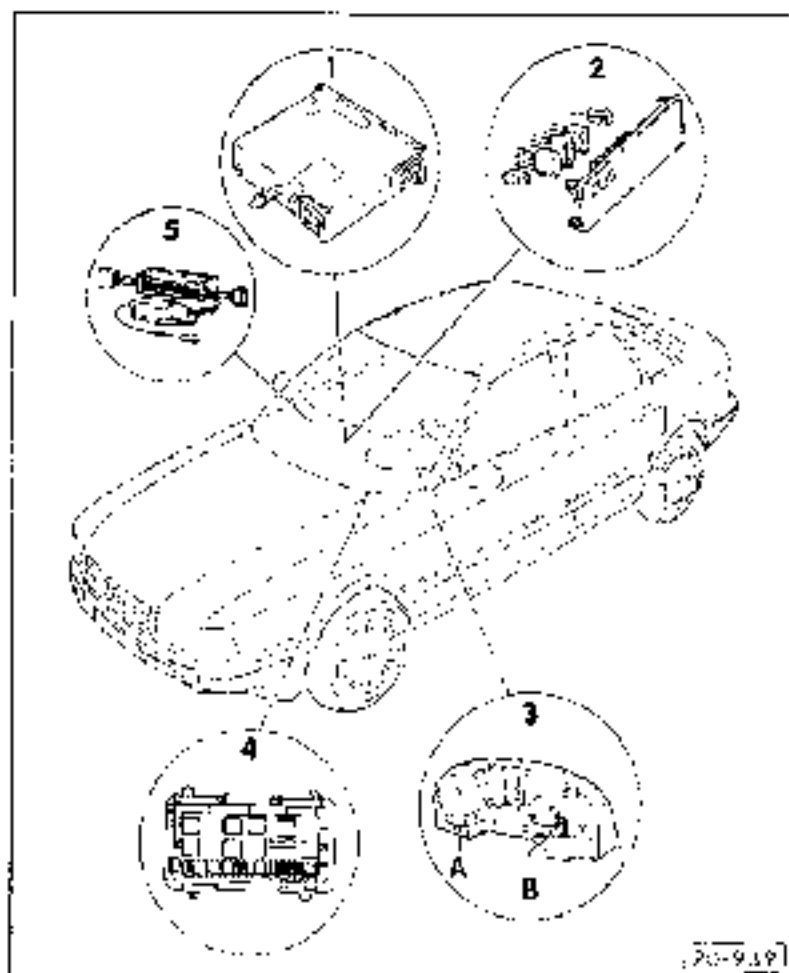

### 3 - Dash panel insert

- ◆ Speed signal tap for radios with GALA function at 26-pin connector -A-
- ◆ Removing, installing and assigning the contacts on the dash panel insert -multipin connectors - > from Page 90-13

### 4 - Relay carrier with fuse box

- ◆ Radio voltage supply
- ◆ Wire routing/fuse assignment - > "Current Flow Diagrams, Electrical Fault Finding and Fitting Locations" binder

### 5 - Amplifier -R12

- ◆ gamma CD radio only
- ◆ Installed in instrument panel
- ◆ 2 x 20 W

91-4

## Removing and installing the radio > 06.94

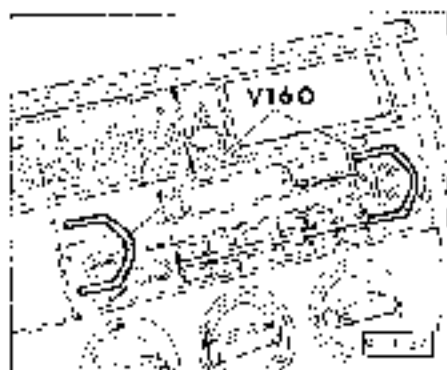

### Note:

Check that the code is present in radios with anti-theft coding.

### Removal:

- Insert the two V160 release clips into the front of the radio, as shown in the illustration.
- Pull the radio out of centre console by pushing the release clips outwards,

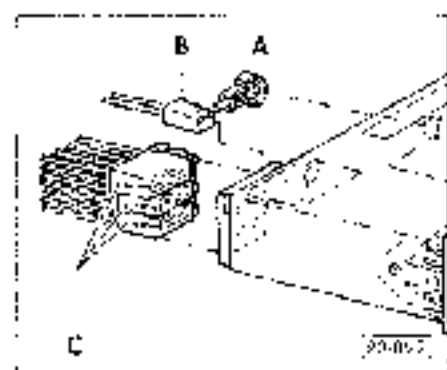

- Pull off aerial connector -A-, earth connection -B- and connector -C- (2 or 3 x).

### Installation:

- Pull the two release clips out of the radio.
- Plug in the connectors.
- Carefully slide radio into centre console until rubber buffer makes contact with bracket at rear.

91-5

## Removing and installing radio 07.94 >



### Note:

Check for presence of anti-theft code.

- Insert release tool 3344 into the front of the radio, as shown.
  - Top L - top left
  - Top R - top right
- Extract radio together with release tool

91-6

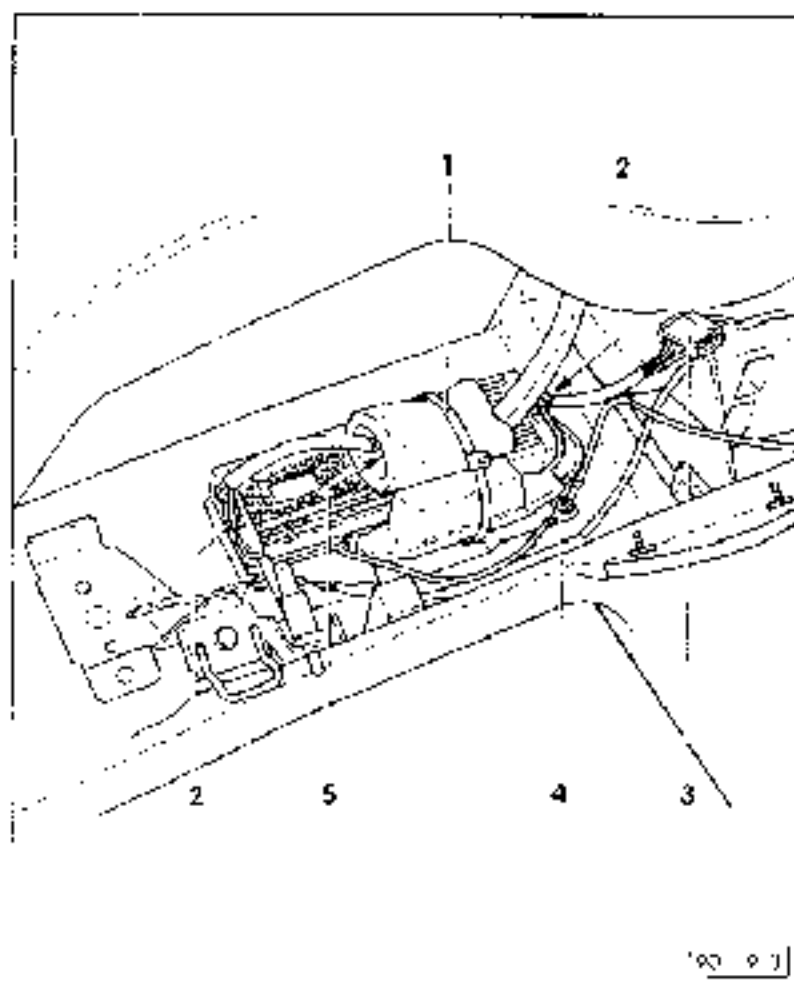

### Removing and installing amplifier ("gamma CD" radio only)

- Removing glove compartment
- > Body Assembly Work: Repair Group 70: Dash Panel; Removing and installing glove compartment - >
- Loosen cable tie -1-
- Remove earth connection screw -4-
- Unplug connectors -3- and -5-
- Loosen fastening screws -2- and remove amplifier.

91-7

### Structure of radio systems

"Alpha" and "Beta" radio > 06.94

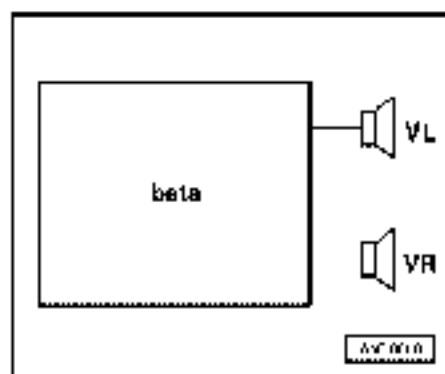

- Front loudspeaker system - passive
- ◆ Wide band loudspeakers, front right and left
- ◆ Installed in instrument panel

<b>Technical data</b>	
Nominal power PN	15 Watts
Music power PM	23 Watts
Nominal impedance ZN	4 Ω
Frequency (transmission range) "alpha" radio	60 ... 17000 Hz
Frequency (transmission range) "beta" radio	50 ... 17000 Hz

91-6



**Rear right and left bass loudspeakers**

- ◆ Fitted in bottom of door.

**Technical data**

Nominal power PN	20 Watts
Music power PM	25 Watts
Nominal impedance ZN	4 Ω
Frequency (transmission range)	50 - 8000 Hz

**Rear right and left mid-range/treble loudspeakers**

- ◆ Installed in top of door trim, connected to/supplied from bass loudspeaker

**Technical data**

Music power PM	25 Watts
Nominal impedance ZN	4 Ω
Frequency (transmission range)	2000 - 16000 Hz

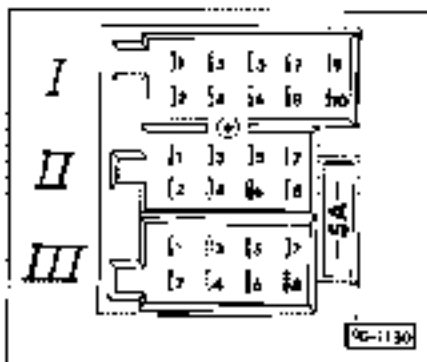
**Assignment of multipin connectors I, II and III on the rear of the radio**

- ◆ Multipin connector I, 10-pin, red

Pin 1	DATA II
Pin 2	Clock 1;
Pin 3	Enable 1)
Pin 5	Earth
Pin 8	Low frequency, rear right 2)
Pin 10	Low frequency, rear left 2)

1) only for 2nd display with auto-check system

2) only for rear active loudspeaker

- ◆ Multipin connector II, 8 pin, brown

Pin 3	Loudspeaker +, passive front right
Pin 4	Loudspeaker -, passive front right
Pin 5	Loudspeaker +, passive front left
Pin 6	Loudspeaker -, passive front left



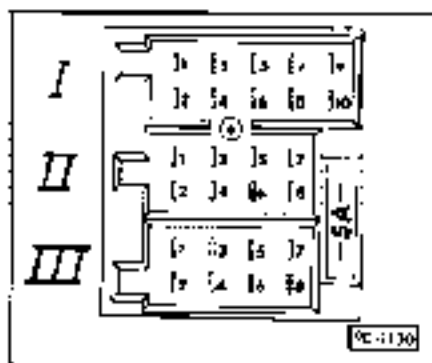

◆ Multipin connector II, 8-pin, black

Pin 1	GATA (speed signal)
Pin 5	Switched positive for serial with electronic amplifier/electronic power aeral
Pin 6	Lighting Item 50 d)
Pin 7	Battery + (term.30)
Pin 8	Battery - Item 311

### "Gamma CD" radio > 06.94

● Front loudspeaker systems - passive with amplifier (booster)

● Rear loudspeaker systems - active

*Note:*

◀ *The system may only be operated with active loudspeakers and amplifier (booster).*

- A - Rear right amplifier (permanently attached to bass loudspeaker)

- B - Rear left amplifier (permanently attached to bass loudspeaker)

- C - Front amplifier (booster)

◆ 2 x 20 W

◆ Removing -> Page 01-7

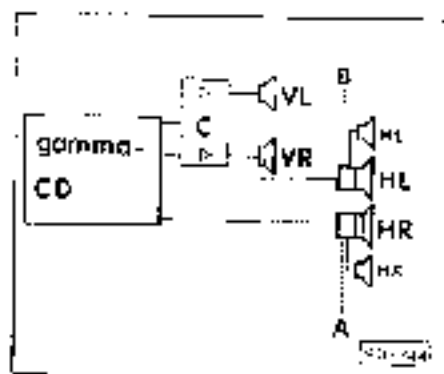

**Front right and left bass loudspeakers**

◆ Installed in instrument panel

**Technical data**

Nominal power PN	15 Watts
Music power PM	25 Watts
Nominal impedance ZN	4 Ω
Frequency (transmission range)	50 ... 17000 Hz

**Rear right and left bass loudspeakers**

◆ Fitted in bottom of door.

**Technical data**

Nominal power PN	20 Watts
Music power PM	25 Watts
Nominal impedance ZN	4 Ω
Frequency (transmission range)	50 ... 8000 Hz

**Rear right and left mid range/treble loudspeakers**

◆ Installed in top of door trim, connected to/supplied from bass loudspeaker

**Technical data**

Music power PM	25 Watts
Nominal impedance ZN	4 Ω
Frequency (transmission range)	2000 ... 16000 Hz

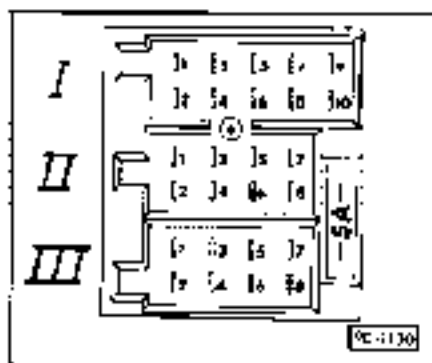

Assignment of multipin connectors I, II and III on the rear of the radio

◆ Multipin connector I, 10 pins

Pin 1	Data 1)
Pin 2	Clock 1)
Pin 3	Enable 1)
Pin 5	Earth
Pin 7	Low frequency, front right 2)
Pin 8	Low frequency, rear right 2)
Pin 9	Low frequency, front left 2)
Pin 10	Low frequency, rear right 2)

1) Only for 2nd display with auto-check system

2) For front and rear loudspeakers (active amplifier booster)

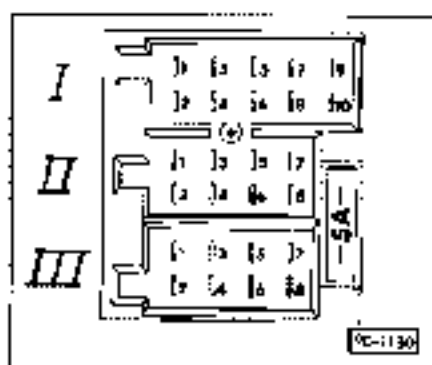

◆ Multipin connector I, 8-pin, brown

- Not connected/cused

◆ Multipin connector II, 8-pin, black

Pin 1	GAL A (speed signal)
Pin 5	Switched positive for aerial with electronic amplifier/electronic power aerial
Pin 6	Lighting Item.58 d)
Pin 7	Battery + (term.30)
Pin 8	Battery - (term.31)

## "Beta" radio 07.94 >

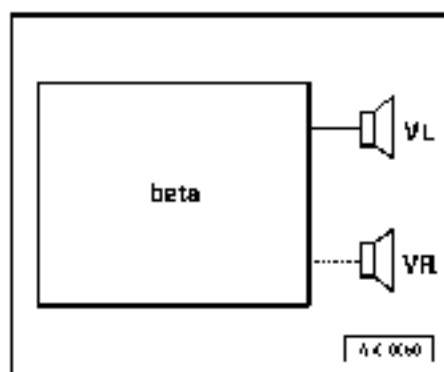

- Front loudspeaker system – passive
- ◆ Wide-band loudspeakers, front right and left
- ◆ Installed in instrument panel

91-19

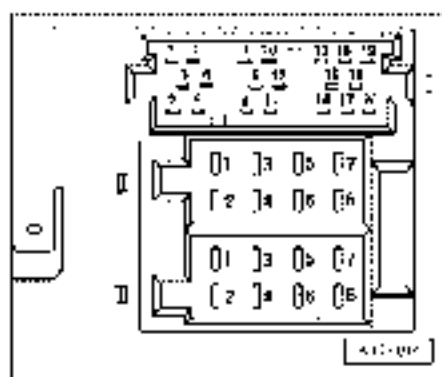

- ◆ Assignment of multipin connectors I, II and III on the rear of the radio

- ◆ Multipin connector I, 20-pin  
– Unallocated
- ◆ Multipin connector II, 8-pin, brown

Pin 3 Loudspeaker +, front right  
 Pin 4 Loudspeaker -, front right  
 Pin 5 Loudspeaker +, front left  
 Pin 6 Loudspeaker -, front left

- ◆ Multipin connector III, 8-pin, black

Pin 2	NF mute circuit
Pin 4	Terminal 86 s
Pin 5	Control positive for aenal
Pin 6	Lighting
Pin 7	Terminal 30
Pin 8	Terminal 31

91-20

## "Gamma" radio 07.94 >

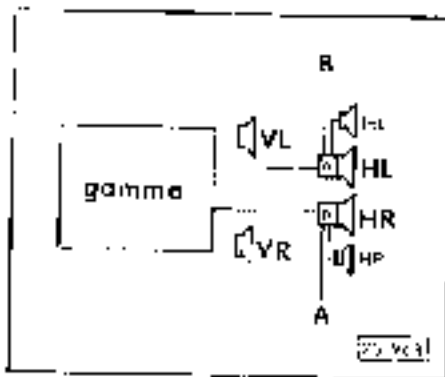

- Front loudspeaker system – passive
- Rear loudspeaker systems – active
  - A - Rear right amplifier (permanently attached to bass loudspeaker in door)
  - A - Rear left amplifier (permanently attached to bass loudspeaker in door)

### Front right and left bass loudspeakers

- ◆ Installed in instrument panel

### Rear right and left bass loudspeakers

- ◆ Fitted in bottom of door.

### Rear right and left mid-range/treble loudspeakers

- ◆ Installed in top of door trim, connected to/supplied from bass loudspeaker

91-21

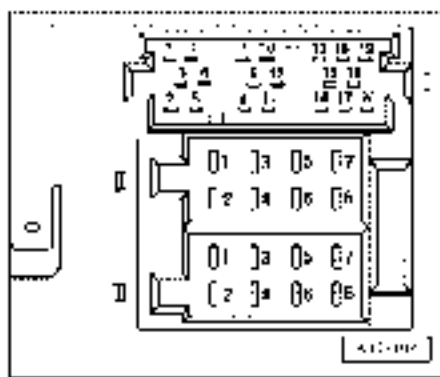

### Assignment of multipin connectors I, II and III on the rear of the radio

- ◆ Multipin connector – 20-pin

Pin 1	Rear left line
Pin 2	Rear right line
Pin 3	Earth line
Pin 6	Loudspeaker control plus
Pin 8	Clock
Pin 9	Data
Pin 10	Enable

91-22

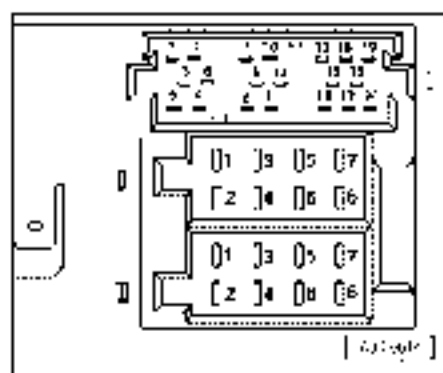

◆ Multipin connector I, 8-pin, brown

Pin 3	Loudspeaker +, front right
Pin 4	Loudspeaker -, front right
Pin 5	Loudspeaker +, front left
Pin 6	Loudspeaker -, front left

◆ Multipin connector II, 8-pin, black

Pin 1	Speed sensor
Pin 2	NF mute circuit
Pin 3	Terminal 30
Pin 4	Terminal 86 s
Pin 5	Control positive for aerial
Pin 6	Lighting
Pin 7	Terminal 30
Pin 8	Terminal 31

91-23

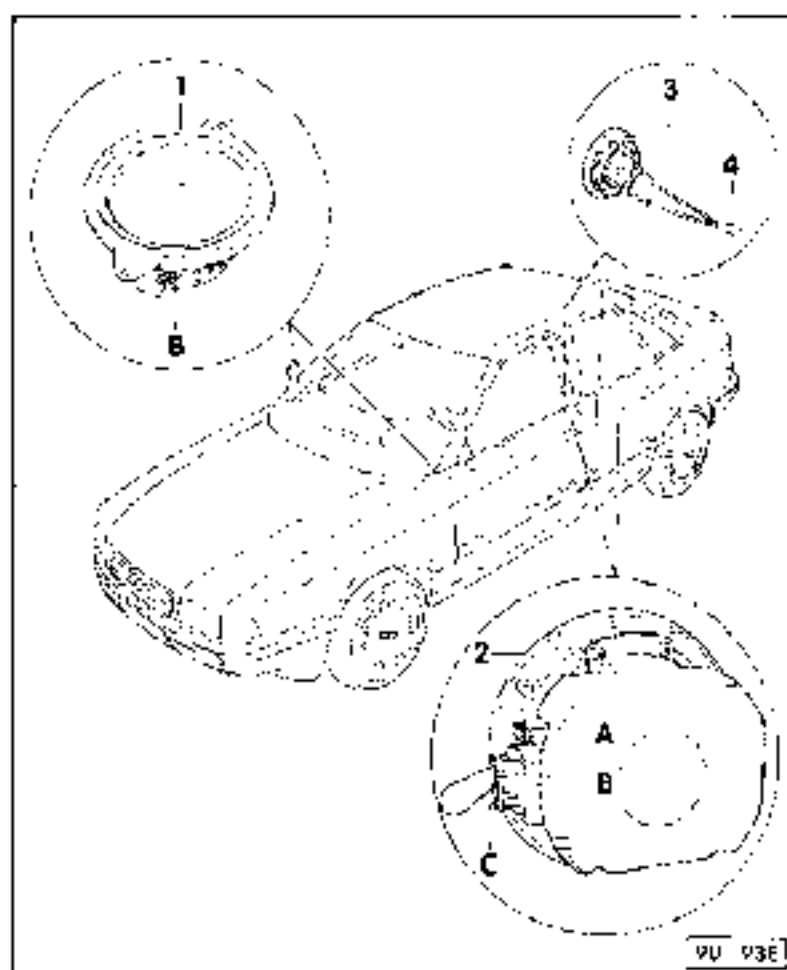

## Layout of loudspeaker systems

### Notes:

- ◆ Technical data for the individual loudspeakers -> from Page 21-6.
- ◆ Wiring and contact assignment -> "Current Flow Diagrams, Electrical Fault Finding and Fitting Locations" binder

### 1 - Passive front loudspeaker

- ◆ Wide band loudspeaker
- ◆ B - connector
- ◆ Removing and installing -> Page 21-20

91-24

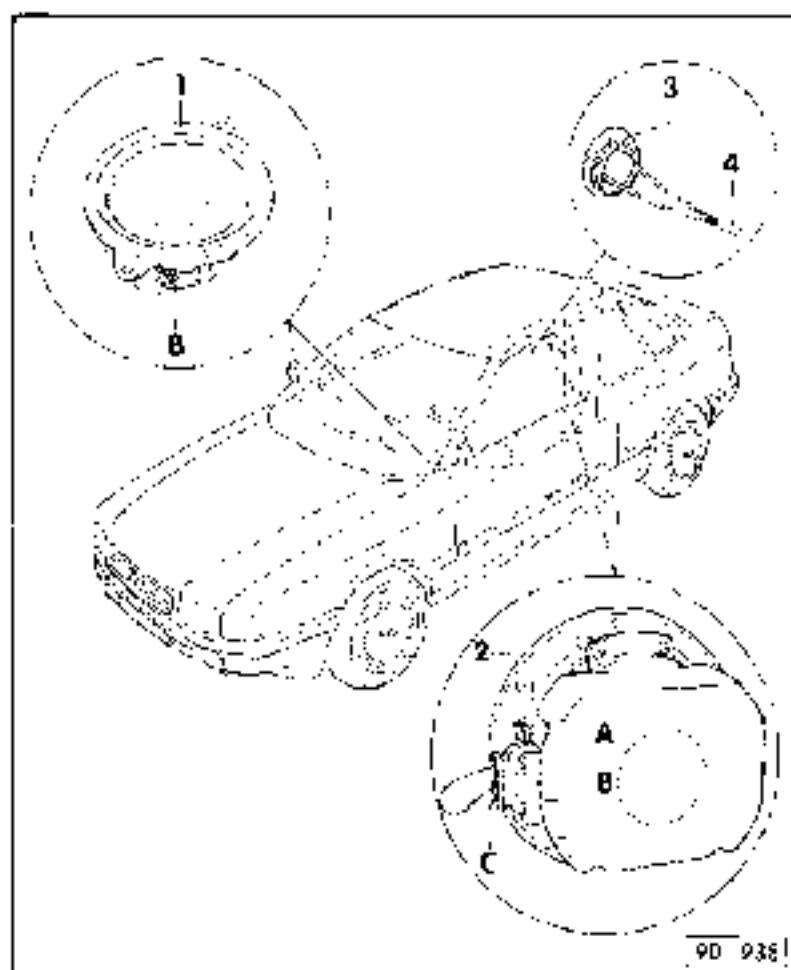

**2 - Rear loudspeaker, passive or active**

- ◆ Passive bass loudspeaker
- ◆ Active bass loudspeaker
- ◆ A - Fuse
- ◆ B - Wing loom connector
- ◆ C - Cable link (absolute prerequisite for operation)
- ◆ Removing and installing - > Page 91-27

**3 - Mid-range/treble loudspeakers**

- ◆ Removing and installing - > Page 91-30

**4 - Connecting cable**

- ◆ For mid-range/treble loudspeaker
- ◆ Connected to bass loudspeaker

90 9381

91-25

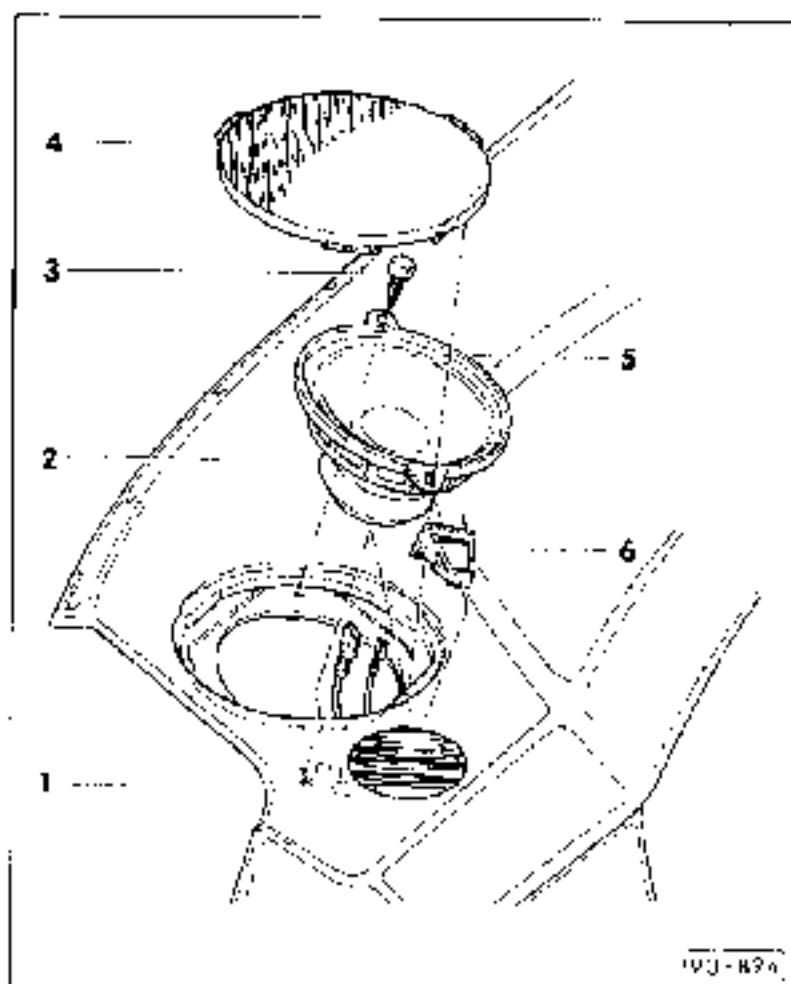

**Removing and installing front loudspeaker**

- Use small screwdriver to carefully prise off trim -4-
- Remove hexagon bolt -3-
- Carefully pull out loudspeaker -5- upwards (avoid touching diaphragm), pull off connector.

**Note:**

Leave socket -6- in holder -1- on instrument panel

- On installation, press home loudspeaker retainer in socket-6-
- Screw in hexagon bolt.
- Press in trim by hand

90 890

91-26

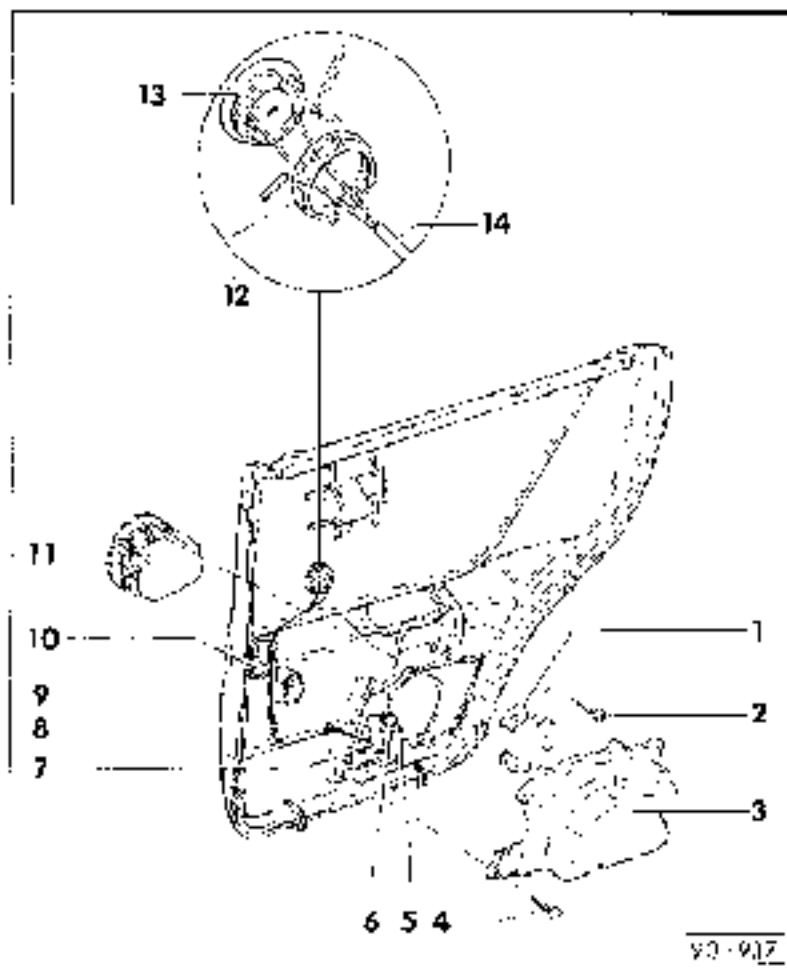

### Removing and installing rear loudspeaker

- 1 - Assembly segment
- 2 - Fastening screw  
◆ 4.2 x 16
- 3 - Loudspeaker bun
- 4 - Fastening screw  
◆ 4.2 x 16
- 5 - 2-pin connector  
◆ For mid-range/treble loudspeaker
- 6 - 5-pin connector  
◆ For bass loudspeaker

91-27

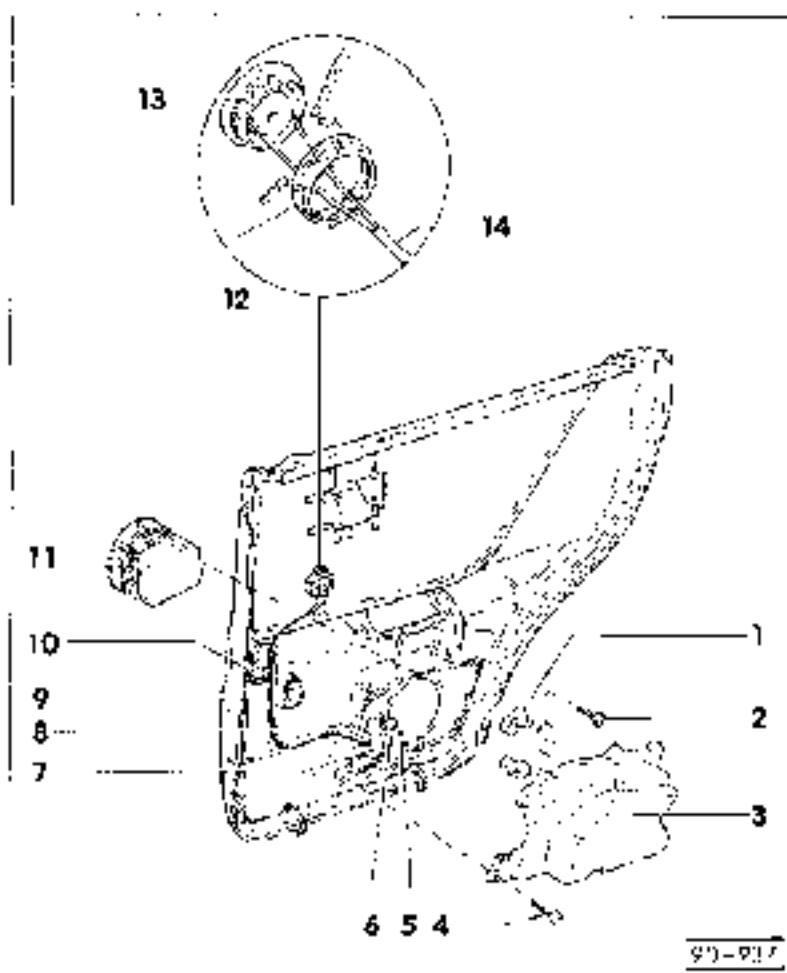

- 7 - Sealed socket  
◆ For cable transition piece
- 8 - Retaining clip  
◆ For loudspeaker wiring loom

9 - Door trim

10 - Receptacle  
◆ For loudspeaker wire

11 - Active or passive bass loudspeaker

◆ Removal

Remove door trim

-> General Body repairs: Repair group 70, Door trim, Removing and installing front door trim (4- and 5-cyl. > DE 93) or removing and installing front door trim (4- and 5-cyl. 07.93 > 6-cyl. S21 ->

91-28



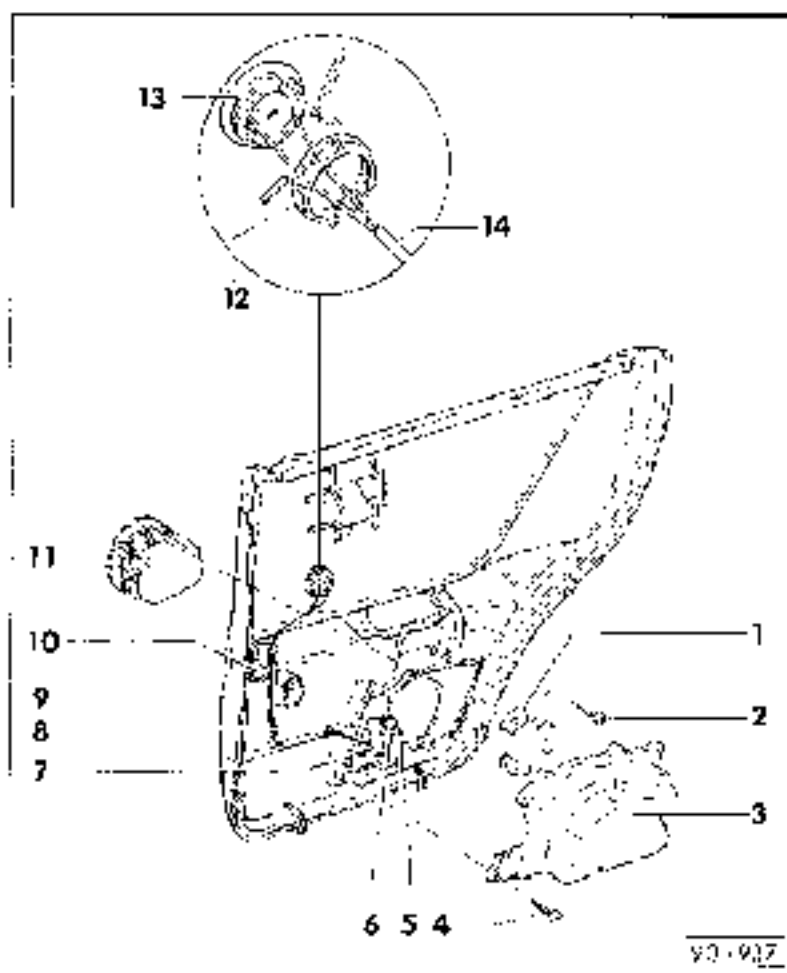

- Pull off connector at receptacle -Item 10-
- Unscrew fastening screws -Item 4- and remove loudspeaker box.
- Pull off connectors -Item 5- and -Item 6-.
- Remove fastening screws -Item 2-.
- Remove assembly segments -Item 1- and take bass loudspeaker out forwards out of door trim -Item 9-.

- 12 Threaded ring**  
 ♦ For attaching mid-range/treble loudspeaker

91-29

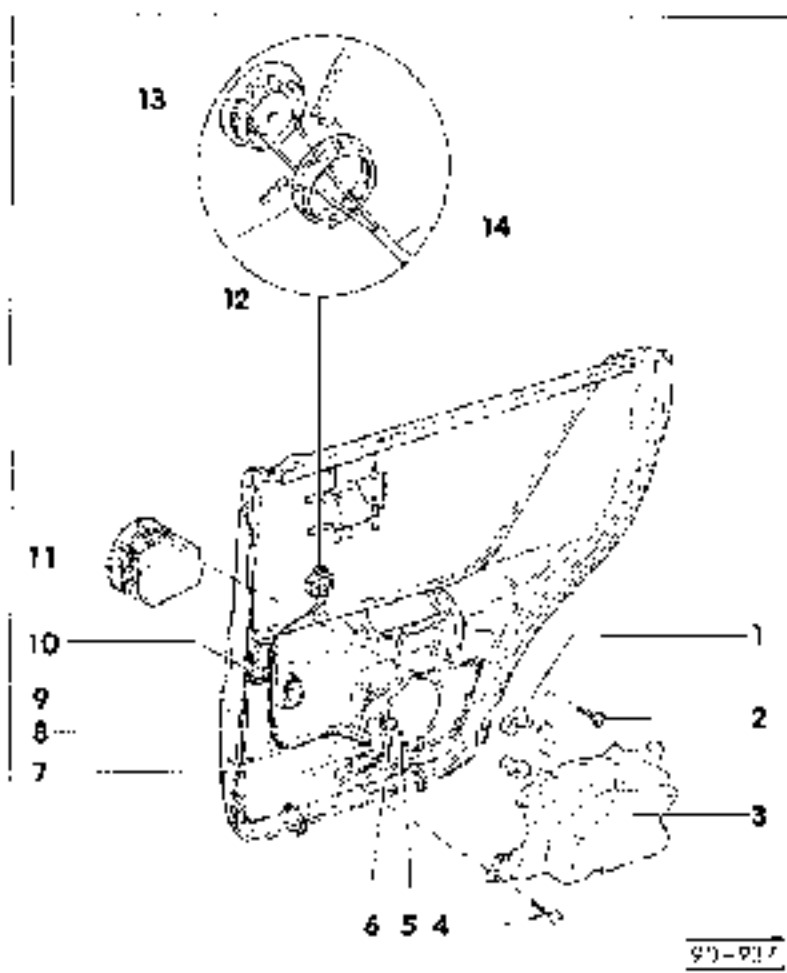

- 13 Mid range/treble loudspeakers**  
 ♦ Removal.
- Remove door trim
  - > General Body repairs, Repair group 70: Door trim; Removing and installing front door trim (4- and 6-cyl. > D6.93) or removing and installing front door trim (4- and 6-cyl. 07-93 >, 6-cyl., S21)->
  - Pull off connector at receptacle -Item 10-
  - Unscrew fastening screws -Item 4- and remove loudspeaker box
  - Pull connector for mid range/treble loudspeaker -Item 5- from bass loudspeaker -Item 11-.

91-30

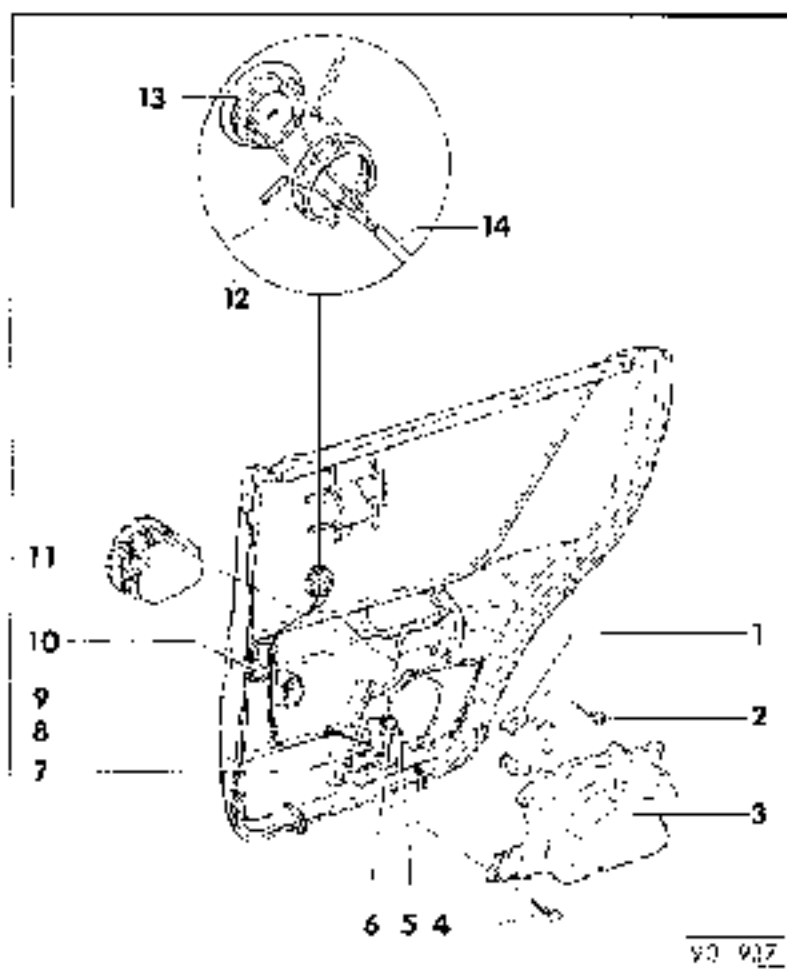

- Remove connecting cable for mid-range/treble loudspeaker - Item 14 - from retaining clip - Item 8 - and socket - Item 7 -.
- Unscrew threaded ring - Item 12 - from mid-range/treble loudspeaker and take mid-range/treble loudspeaker forwards out of door trim - Item 9.

- 14 - Connecting cable  
 ◆ For mid-range/treble loudspeaker

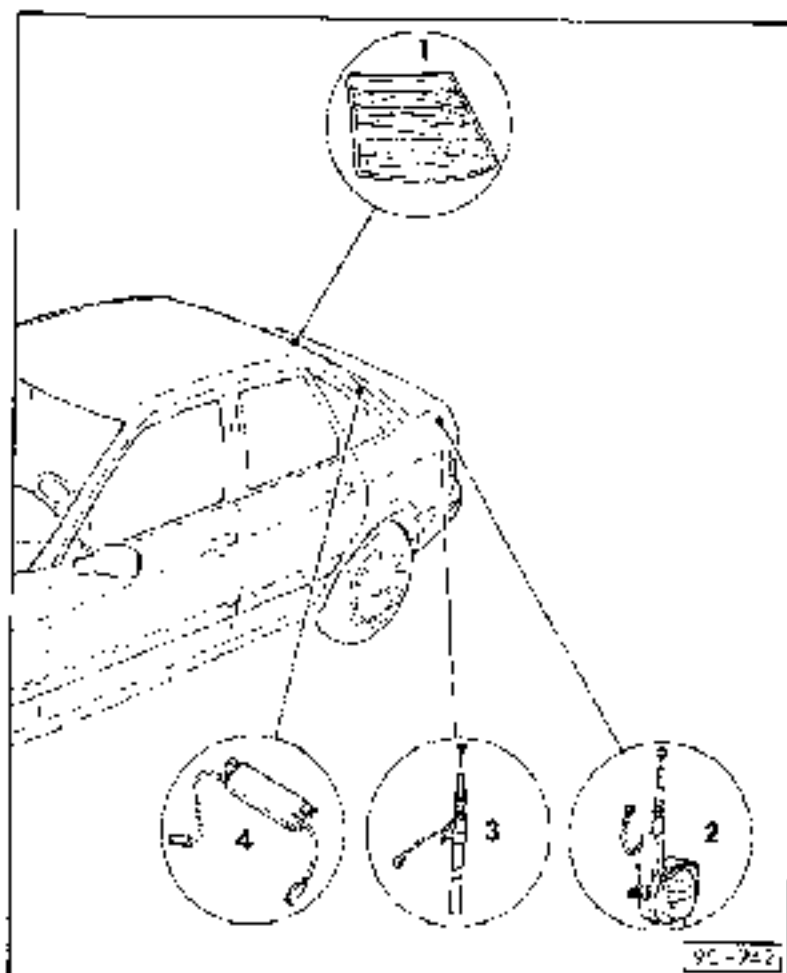

## Layout of aerial systems

### Notes:

- ◆ When retrofitting it is advisable to use a telescopic or power aerial. Dimensions for subsequent installation -> Fig. 2.
- ◆ Repairing roof aerial  
 Avant > 06.94 -> Page 91-10.  
 Avant 07.94 > -> Page 91-14.

- 1 - Heated rear windscreen with window aerial Z24  
 ◆ Top 3 filaments not heated: MW aerial only (AM);  
 ◆ Remaining filaments: Heater and VHF aerial (FM)  
 ◆ Removing and installing  
 > General Body Repairs: Repair Group 64: Removing and installing rear window; Removing and installing (saloon) >

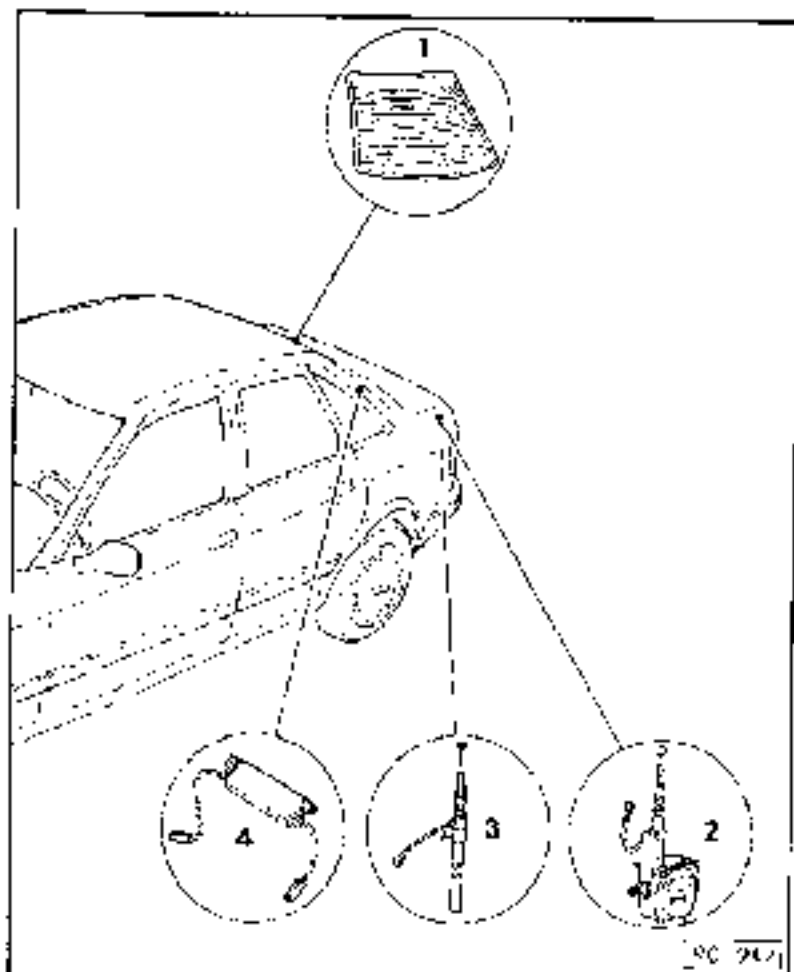

### 2 - Power aerial

- ◆ Only with special thermally-insulated glass
- ◆ Removing and installing - > Page 91-33
- ◆ Subsequent aerial installation - > Fig. 2
- ◆ Wiring and contact assignment

- > "Current Flow Diagrams, Electrical Fault Finding and Fitting Locations" binder

### 3 Rod aerial

- ◆ Removing and installing - > Page 91-33
- ◆ Subsequent aerial installation - > Fig. 2

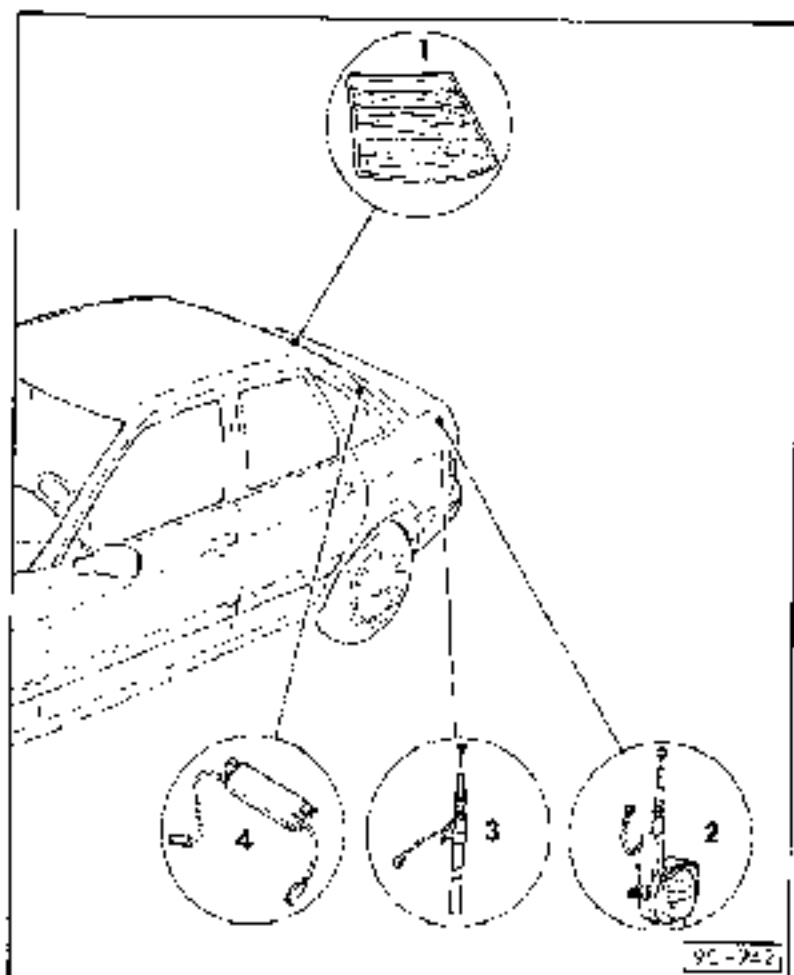

### 4 Aerial amplifier R24

- ◆ only in conjunction with window aerial
- ◆ Location: Inside of left D pillar
- ◆ Removing and installing - > Fig. 1
- ◆ Troubleshooting

- > "Current Flow Diagrams, Electrical Fault Finding and Fitting Locations" binder

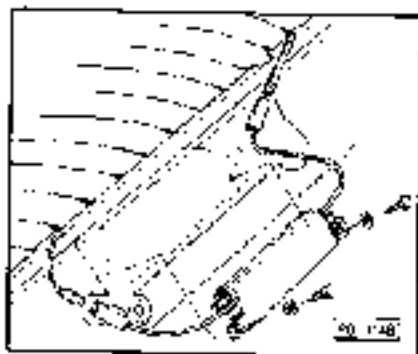

◀ Fig.1 Removing and installing aerial amplifier

- Remove inner D pillar trim
- Unscrew aerial cable and pull off all connectors.
- Loosen hexagon screws and remove aerial amplifier.
- Ensure that there is a good earth connection when installing.

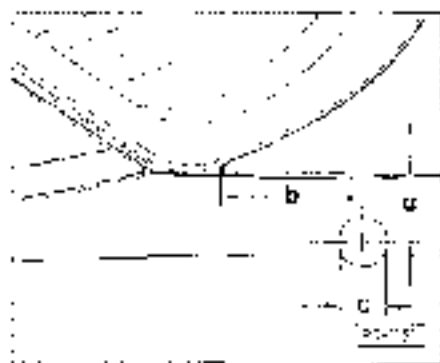

◀ Fig.2 Subsequent aerial installation.

● Power and rod aerial

*Note:*

*When retrofitting an aerial, original spare parts (Vortex) must be used. Other commercially available aeriels may not fit correctly and cause wind noise at high speed.*

- Mark dimensions for aerial hole on rear left side panel using left or fibre-tipped pen.
  - Distance a = 50 mm
  - Distance b = 120 mm
  - Dimension c = 16.5 mm

Drill aerial hole and carefully deburr.

- Carefully extract/remove all shavings and filings (avoid scratches)

- Repair paintwork around hole as specified
- > Vehicle paintwork
- Take anti-corrosion measures if necessary
- > "Surface treatment/chemical materials" binder
- Installing telescopic or power aerials.
- Install and connect cabling
- > "Current Flow Diagrams, Electrical Fault Finding and Fitting Locations" binder

91-37

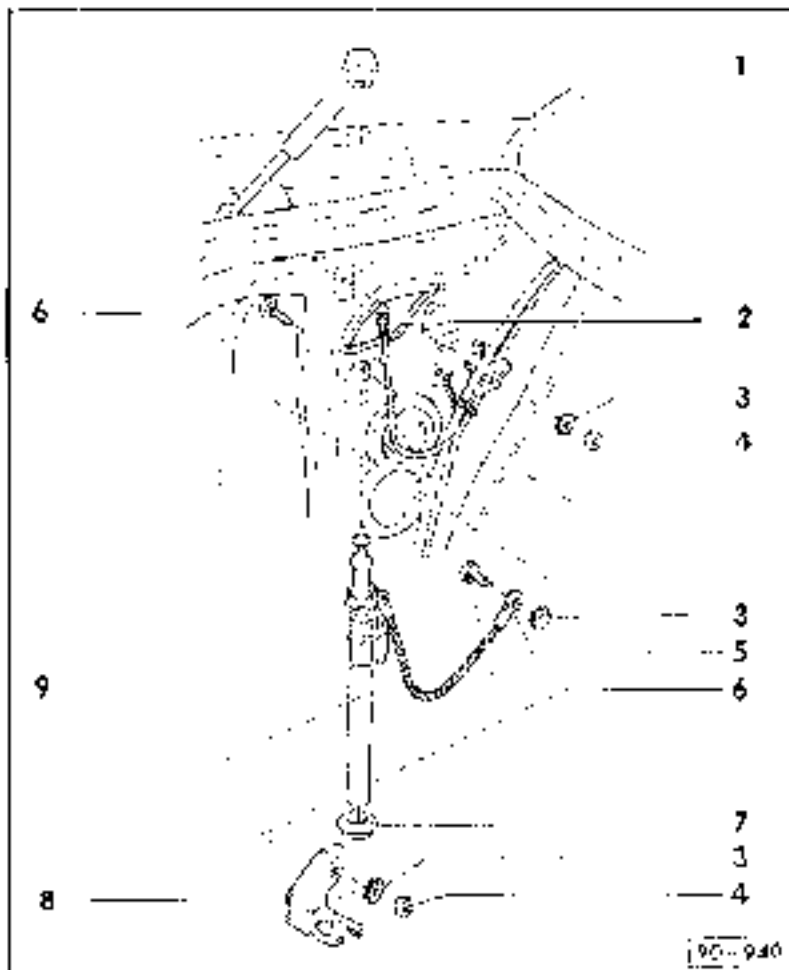

#### Removing and installing rod aerial

- 1 - Sealed socket
- 2 - Aerial cable
- 3 - Toothed washer, 5 mm
- 4 - Hexagon nut M5
- 5 - Earthing strap for aerial
- 6 - M5 hexagon nut (10 κ) 2.5 Nm
- 7 - Rubber grommet
- B - Bracket

91 38

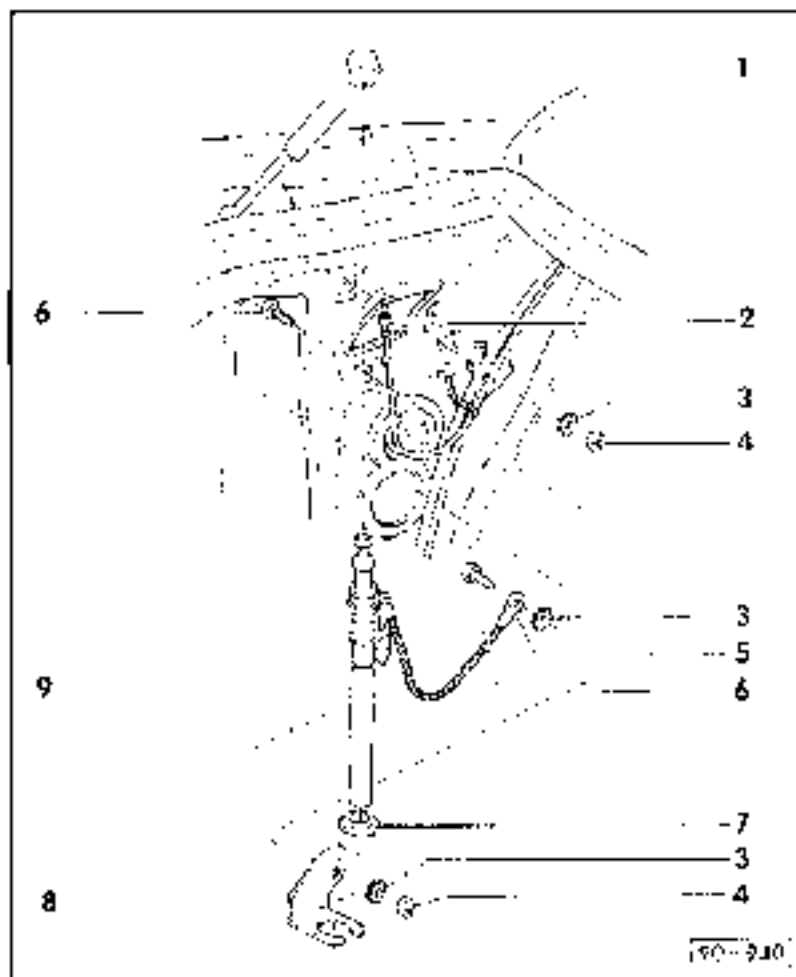

**9 - Rod aerial**

◆ Removal.

Remove hexagon bolts - Item 6- for bracket and earthing strap.

- Unscrew aerial cable -Item 2-

- Pull rod aerial with bracket - Item 8- downwards out of socket -Item 1- by pulling and pressing firmly on telescopic head.

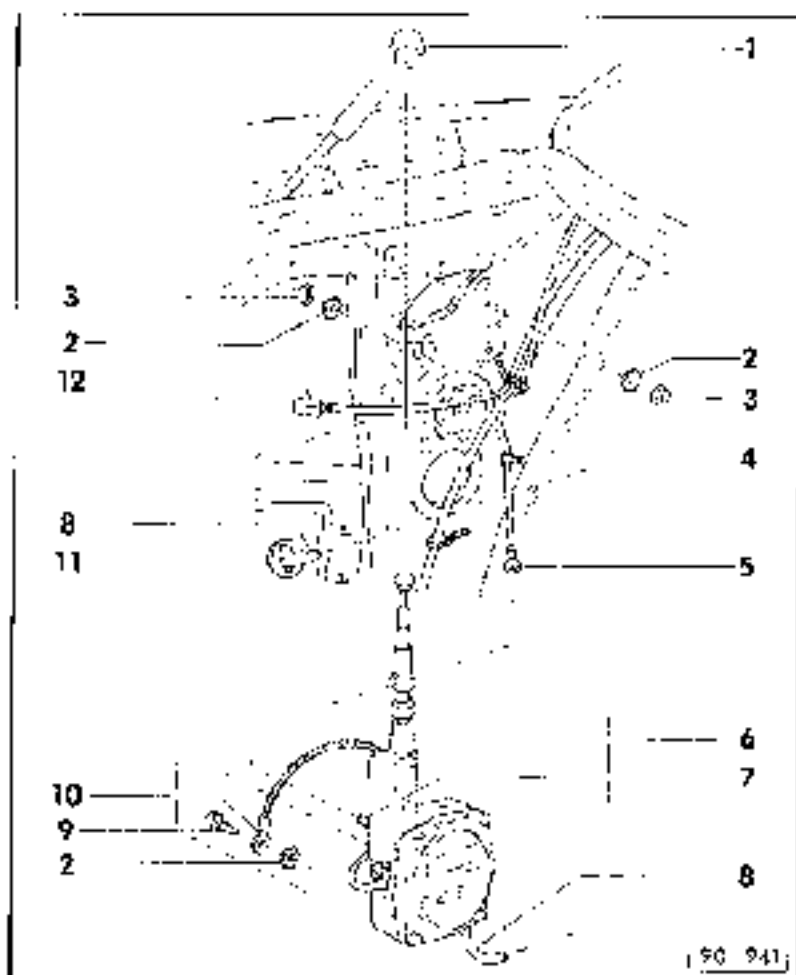

**Removing and installing power aerial**

1 - Sealed socket

2 - Toothed washer, 5 mm

3 - Hexagon nut M5, 2,5 Nm

4 - Earthing clip for aerial cable

◆ Secured with hexagon bolt - Item 8-

5 - Aerial cable

6 - Electronic power aerial

◆ Removal:

- Remove both hexagon nuts - Item 3- for power aerial and earthing strap -Item 10-

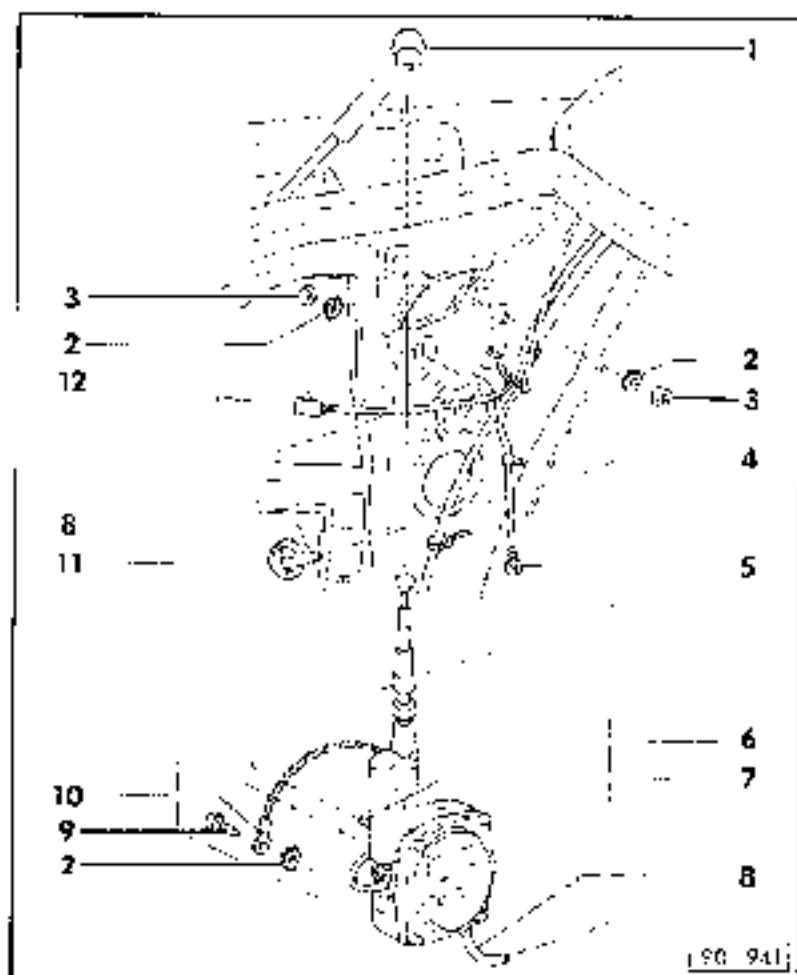

- Remove aerial cable (item 5, connector - item 12- and water drain hose - item 8)
- Pull power aerial downwards out of socket (item 1) by pulling and pressing firmly on telescopic head.

- 7 - Threaded pin M5
  - ◆ Permanently installed in power aerial
- 8 - Water drain hose
- 9 - Hexagon bolt M5 x 10
- 10 - Earthing strap for aerial
- 11 - Rubber grommet
  - ◆ For water drain hose
- 12 - Connector
  - ◆ For power aerial

91-41

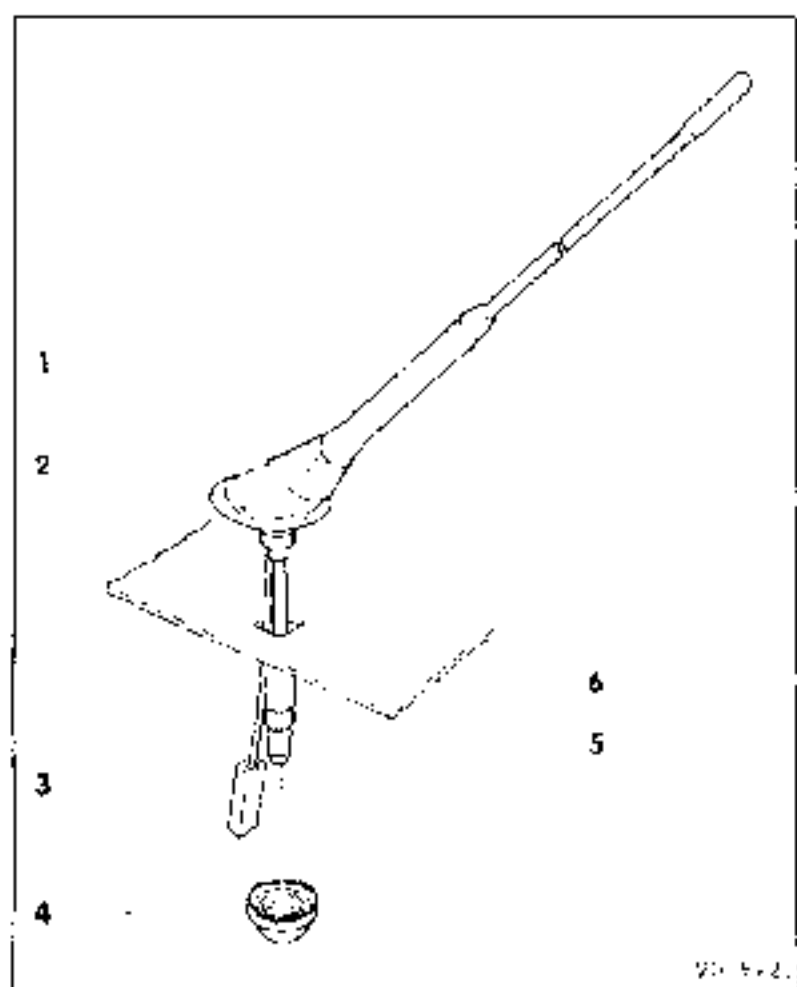

#### Avant roof aerial > 06.94

*Note:*  
 Removing and installing roof aerial  
 => Page 51-45

- 1 - Aerial rod
- 2 - Aerial base
- 3 - Connector
- 4 - Securing nut 3,5 Nm
- 5 - Aerial cable connection
- 6 - Roof skin

91-42

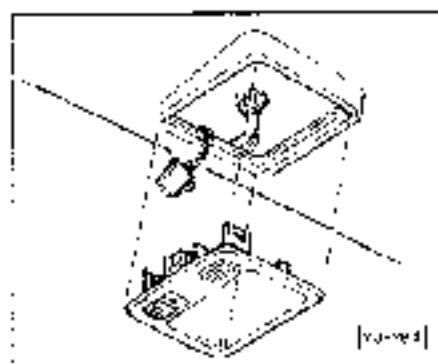

### Removing and installing roof aerial

- ◀ Switch off radio.
- Carefully prise out boot light using flat screwdriver.
- Remove plug.

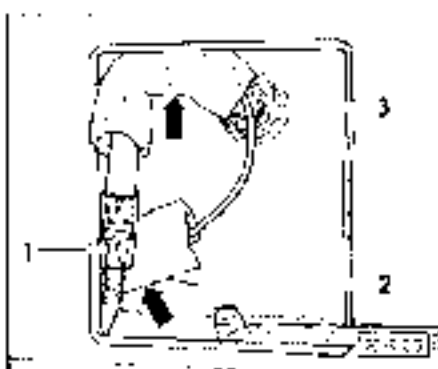

- ◀ Push back foam tubes. Arrows
- Loosen screw connection 1 and plug in connector 2.
- Unscrew fastening nut 3 (3.5 Nm).
- Remove roof aerial from above.

91-43

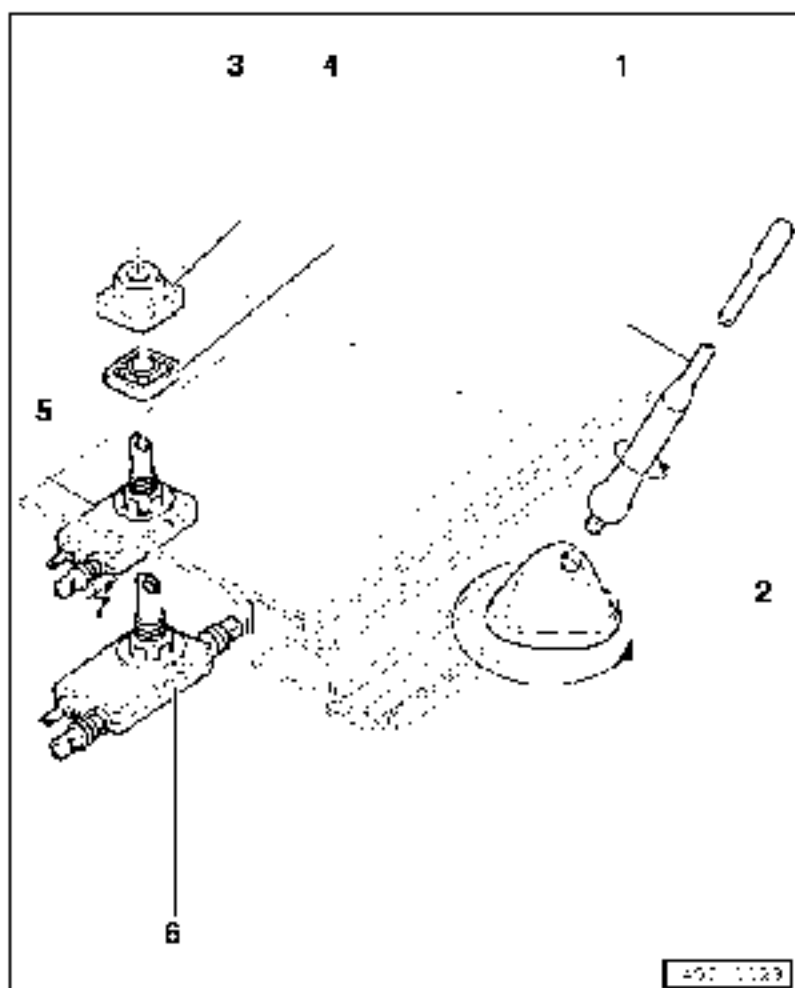

### Roof aerial with amplifier, Avant 07.94 >

**Note:**

Removing and installing roof aerial with amplifier - > Page 51 45.

- 1 - Aerial rod
- 2 - Cover
- 3 - Securing nut - 3.5 Nm
- 4 - Seal
- 5 - Aerial base with amplifier  
♦ For radio operation
- 6 - Aerial base with amplifier  
♦ For radio and telephone operation (if telephone installed)
- 7 - Aerial cable locking mechanism

91 44



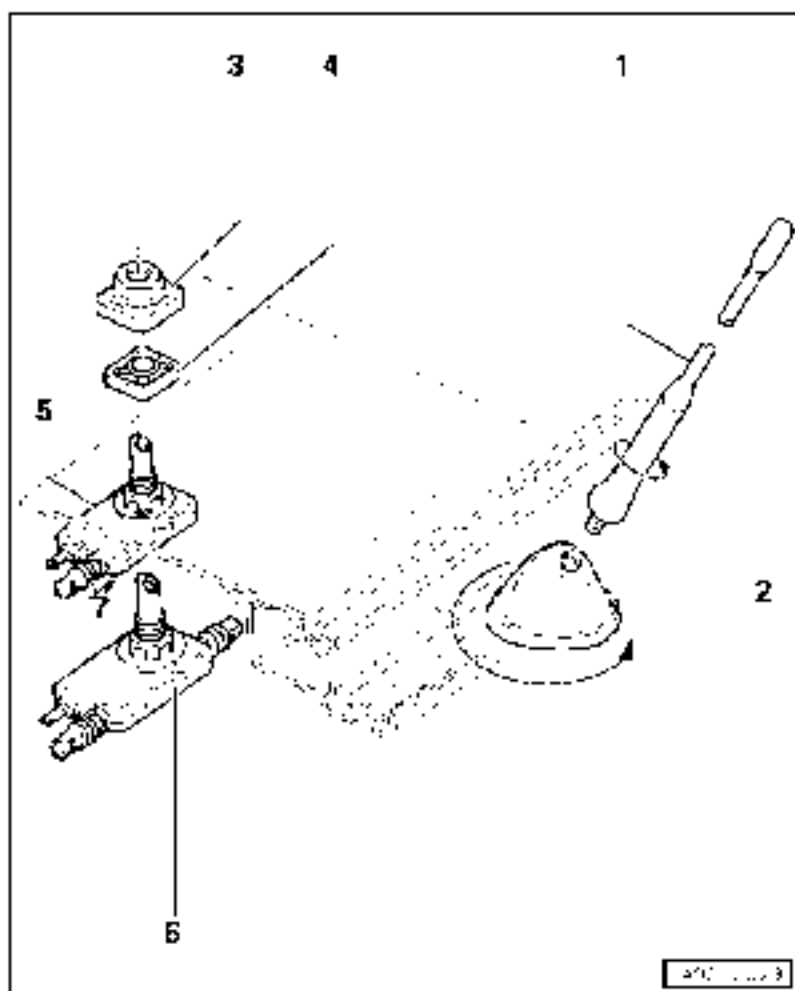

### Removing and Installing roof aerial with amplifier.

- Switch off radio.
- Carefully prise out boot light using flat screwdriver.
- Screw out aerial rod -1-
- Turn cover -2- 1/4 turns to the left and pull off from above
- Unscrew nut -3-
- Remove seal -4-

— 91-45 —

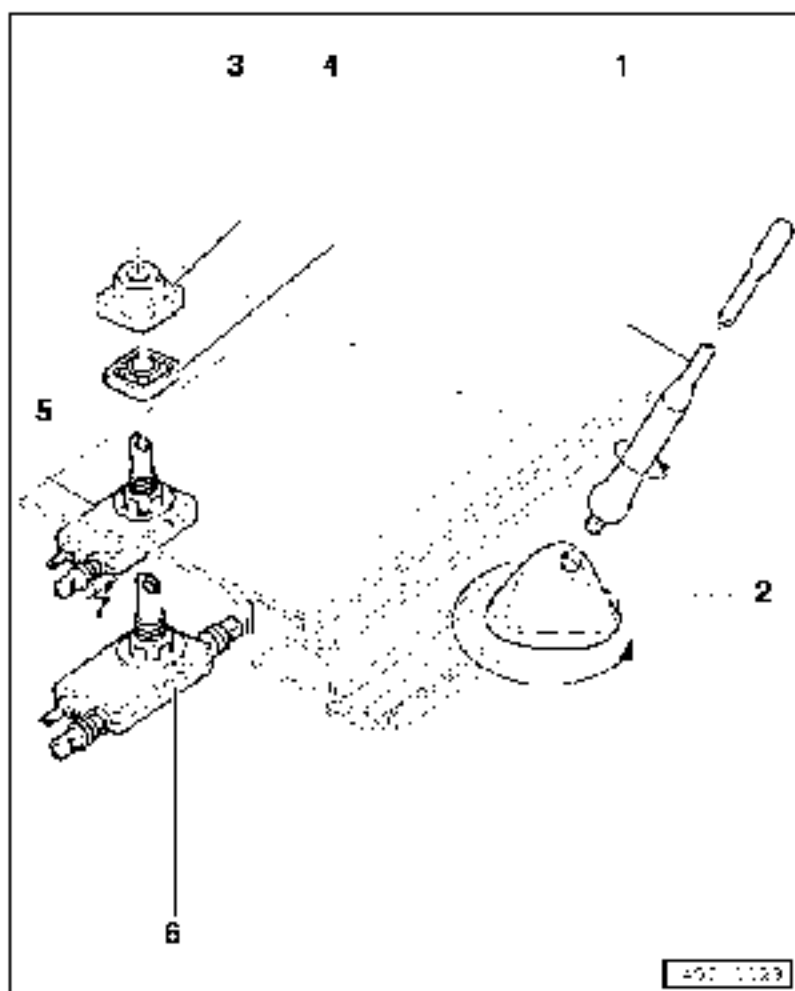

### Release aerial cable locking mechanism 7 in direction of arrow.

- Remove power supply connector.
- Pull off aerial base -5- or -6- downwards.

— 91-46 —

## Servicing windscreen washer system

### Warning

Always switch off Ignition when performing assembly work on installed wiper motor.

### Note:

Wiper motor can only be removed complete with frame. To do this, remove cowl, mounting rail and water guard.

- 1 Wiper blade
- 2 Wiper arm
  - ◆ Adjusting -> Fig. 2

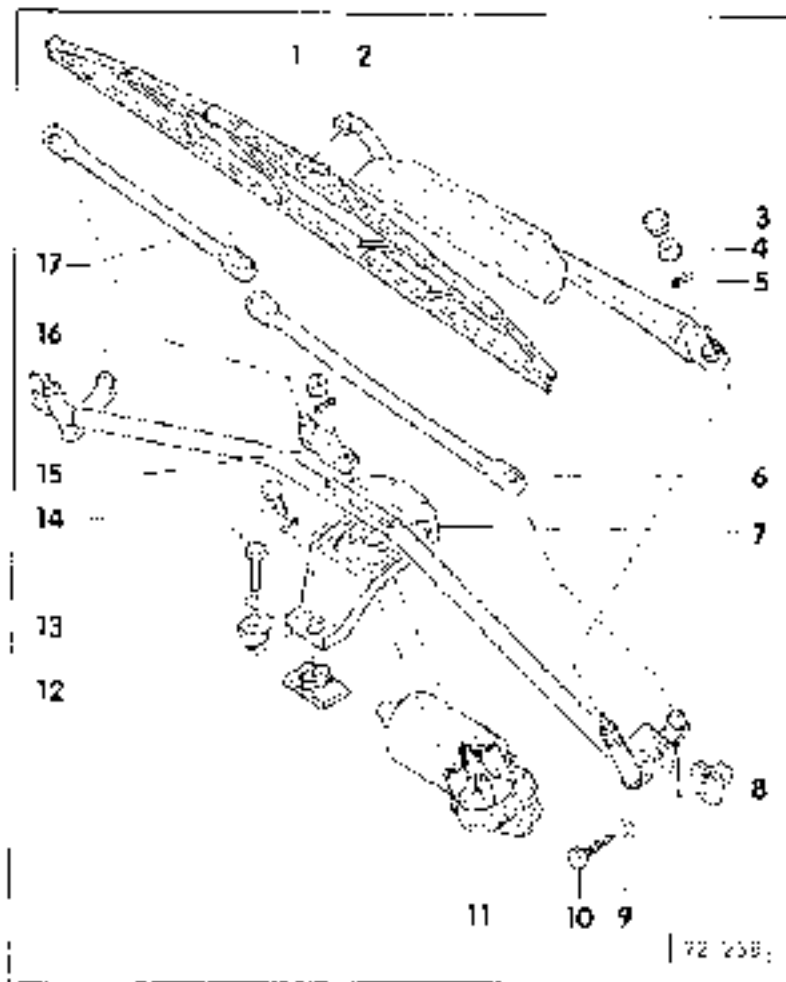

92-1

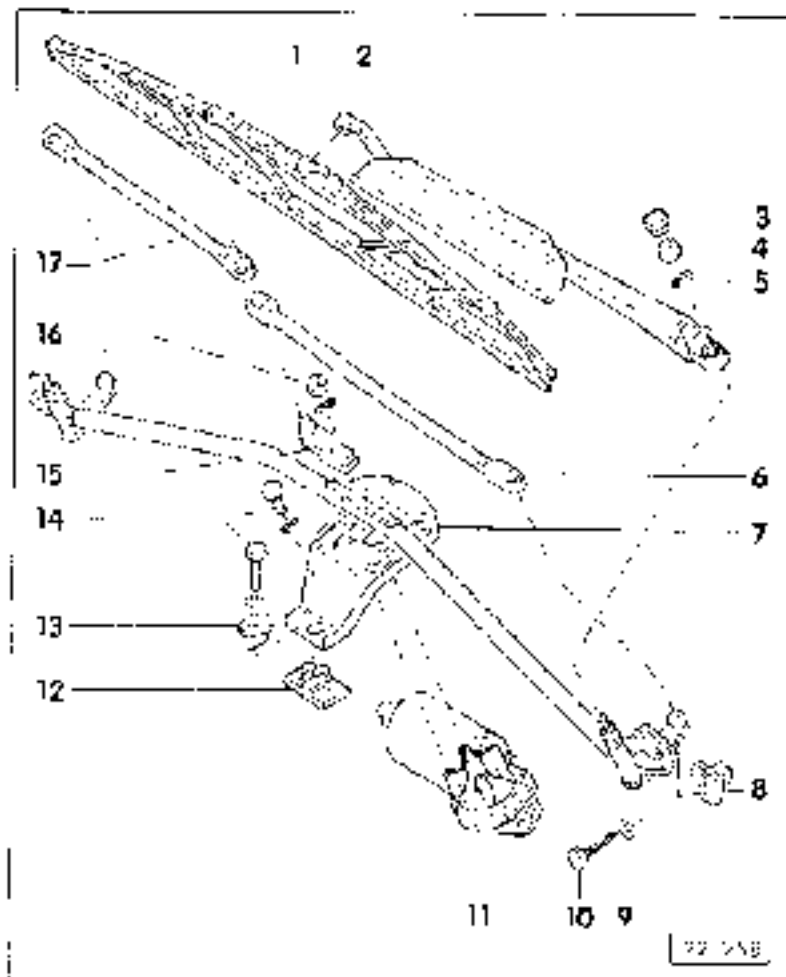

- 3 Trim cap
  - ◆ Prise off
- 4 - MS nut - 16 Nm
- 5 - Washer
- 6 Lever off left thrust rod
  - ◆ and coat bearing shells with MoS<sub>2</sub>-grease.
- 7 Windscreen wiper frame
  - ◆ with firmly compacted wiper bearings
  - ◆ If repair required, replace on the windscreen washer frame, including both wiper bearings.
  - ◆ Removing -> Fig. 1

92 2

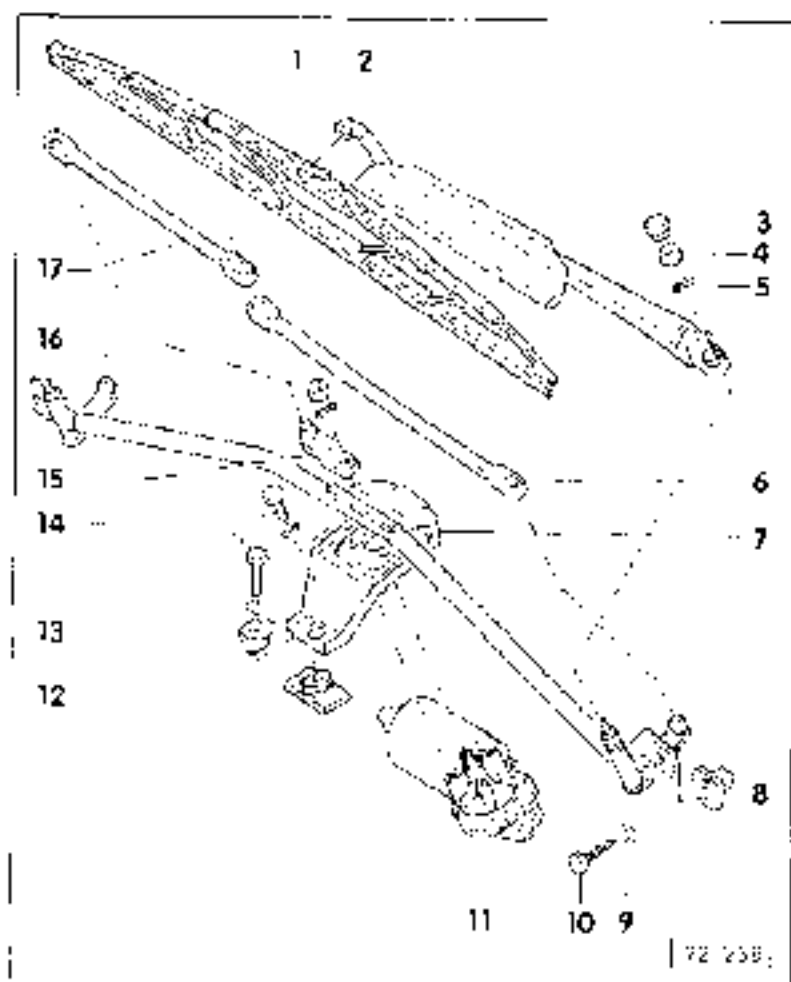

6 - Clip

9 Washer

10 - Hexagon self-tapping bolt

11 - Wiper motor

◆ Remove and install only with wiper frame removed

◆ Removal

- Lever off thrust rods.

- Remove 3 fastening screws.

- Remove motor.

12 - Rubber plate

13 - socket

— 92-3 —

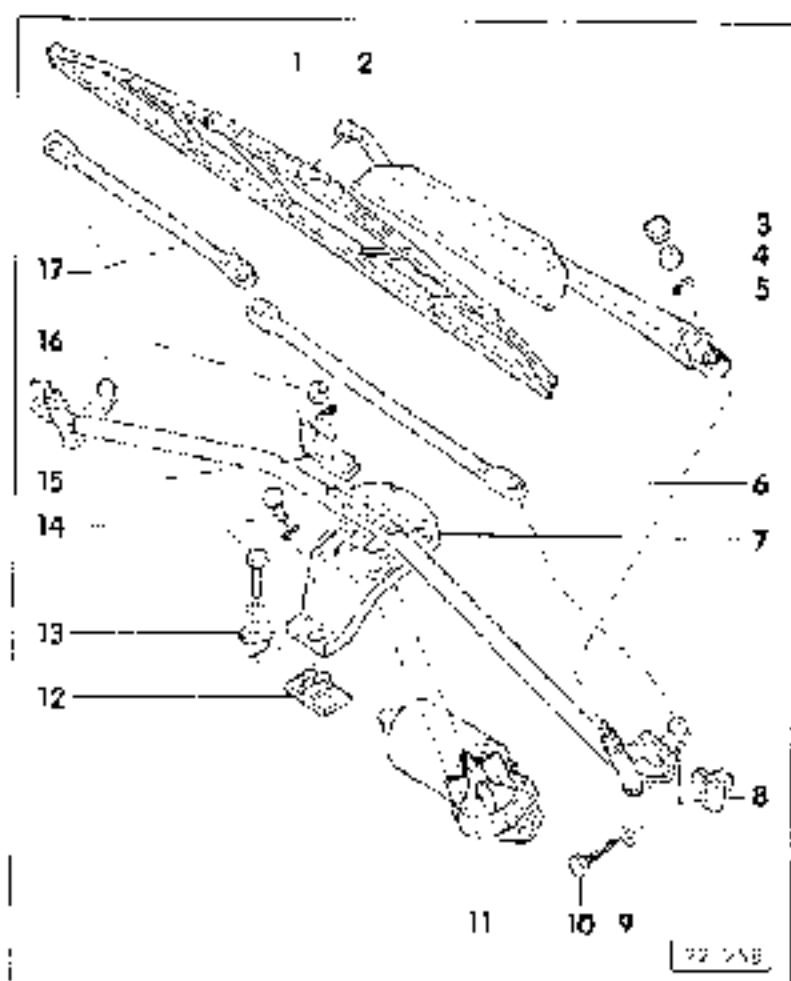

14 Securing bolts

15 - Crank

◆ Installation position -> Fig 3

16 - Nut - 22 Nm

17 - Lever off right thrust rod

◆ and coat bearing shells with MoS2-grease.

— 92 4 —

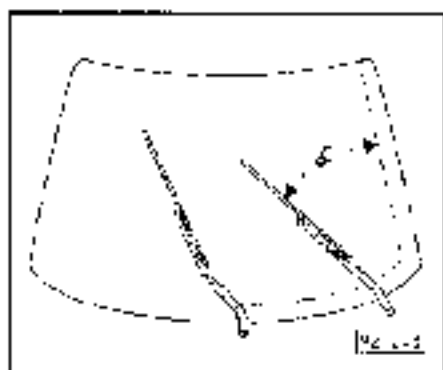

◀ **Fig.1 Wiper arm assembly position**

- Switch ignition on.
- Operate wipers until left wiper arm is in following position:
  - / - approx. 45°
- Switch off ignition.
- Remove wiper motor together with wiper frame

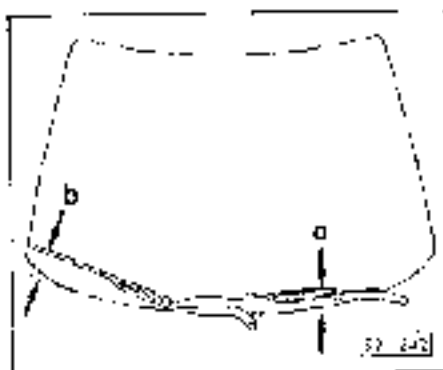

◀ **Fig.2 Wiper arm adjustment**

- Move wiper motor to park position.
  - Switch ignition on.
  - Switch on connected wiper motor and switch off using wiper switch. Wiper motor stops in park position.

Set wiper arm (passenger side) to dimension b = 90 mm and tighten (16 Nm);

Set wiper arm (driver's side) to dimension b = 65 mm and tighten (15 Nm);

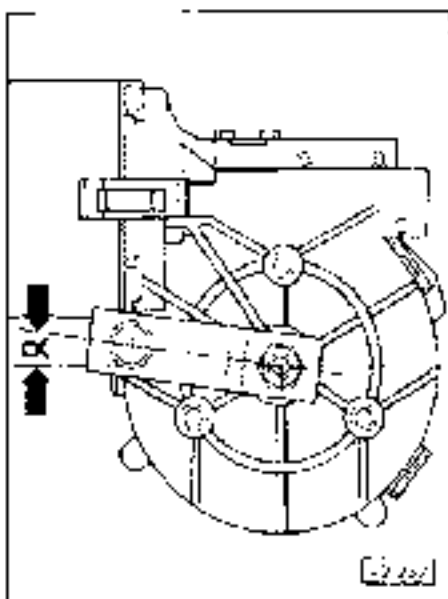

◀ **Fig.3 Crank installation position**

- Allow wiper motor to run to park position and install
- Put on the crank and align.
  - / - approx. 6°

## Servicing windscreen washer system and headlight washer system

### Note:

#### Troubleshooting

-> "Current Flow Diagrams, Electrical Fault Finding and Fitting Locations" binder

#### 1 - Heated jet

- ◆ for windscreen washing system
- ◆ Adjusting -> Fig. 1
- ◆ Removing and installing -> Page 92-7

#### 2 - Connection socket, right

- ◆ Pull off connection before removing jet

#### 3 Jet

- ◆ for windscreen washing system
- ◆ Adjusting -> Fig. 1
- ◆ Removing and installing -> Page 92-7

#### 4 Retaining clip

#### 5 - Connection socket, left

- ◆ Pull off connection before removing jet

#### 6 - Filler neck

- ◆ Removing and installing -> Page 92-15

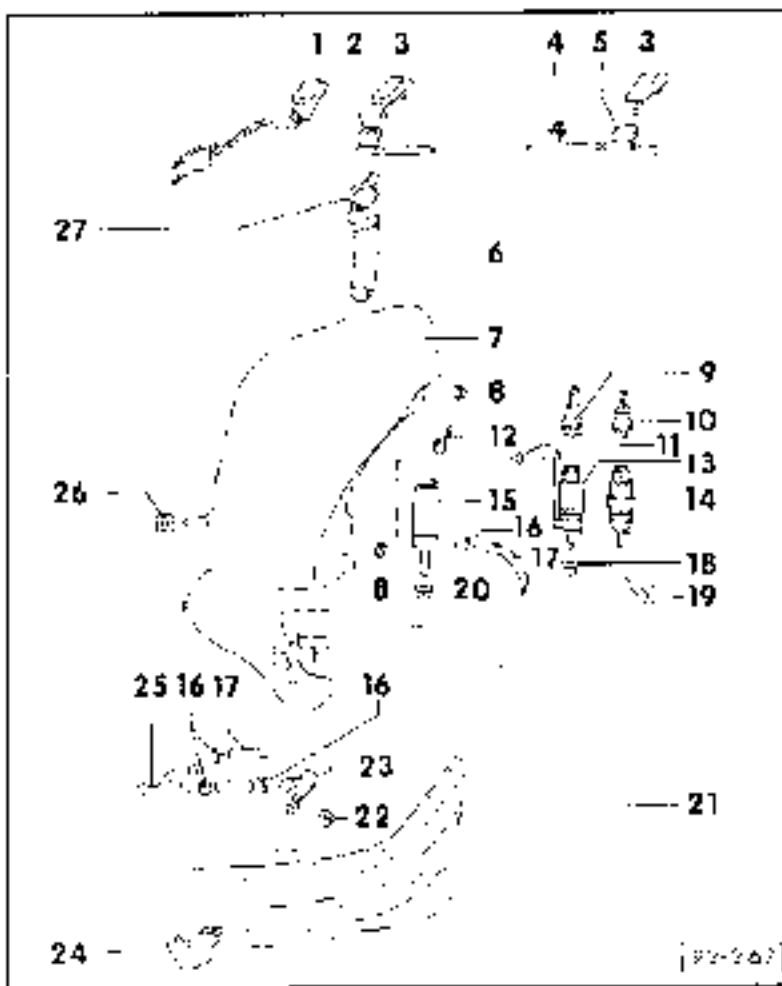

92-7

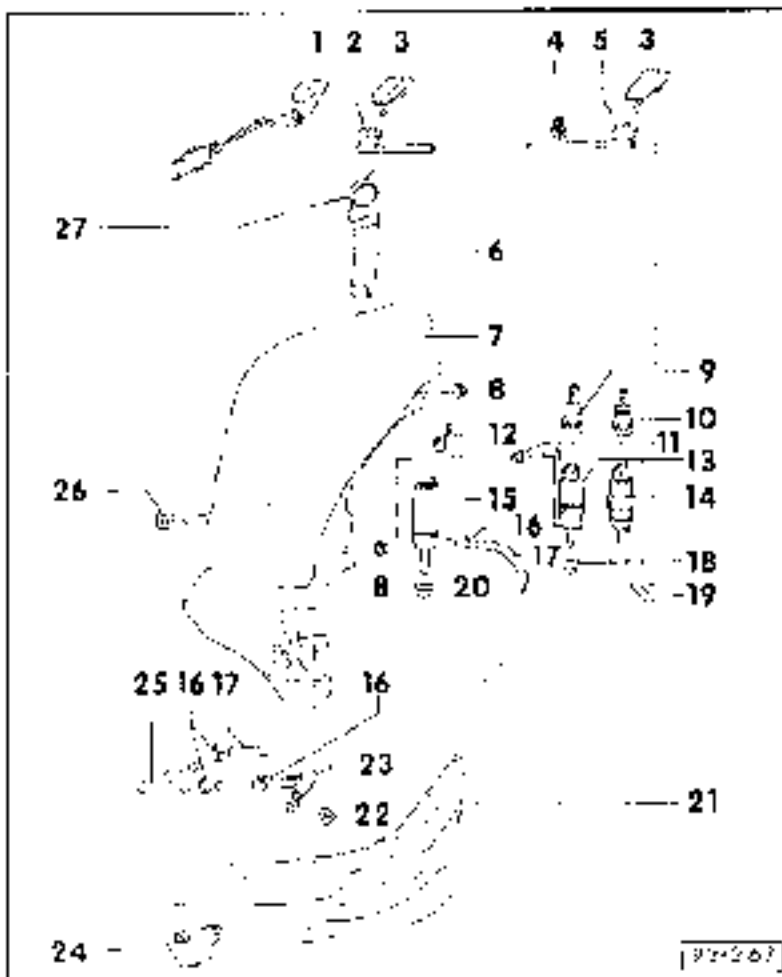

92-6

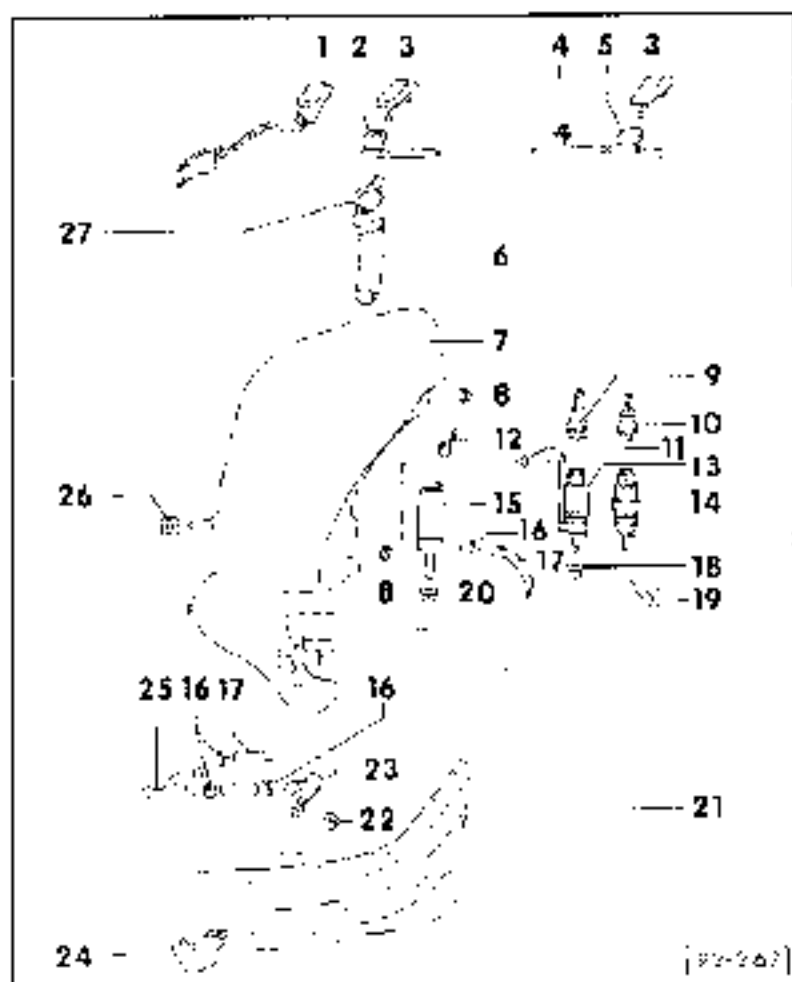

- 7 - Reservoir**
- ◆ For windshield washer system, capacity approx. 4,0 l
  - ◆ For windshield and headlight washer systems, capacity approx. 6,5 l
  - ◆ Removing and installing -> Page 10-10

**8 - Combination nut, 5 Nm**

- 9 - Connector**
- ◆ For windshield washer system pump in vehicles with auto-check system

- 10 - Connector**
- ◆ For windshield washer system pump in vehicles with no auto-check system

92-9

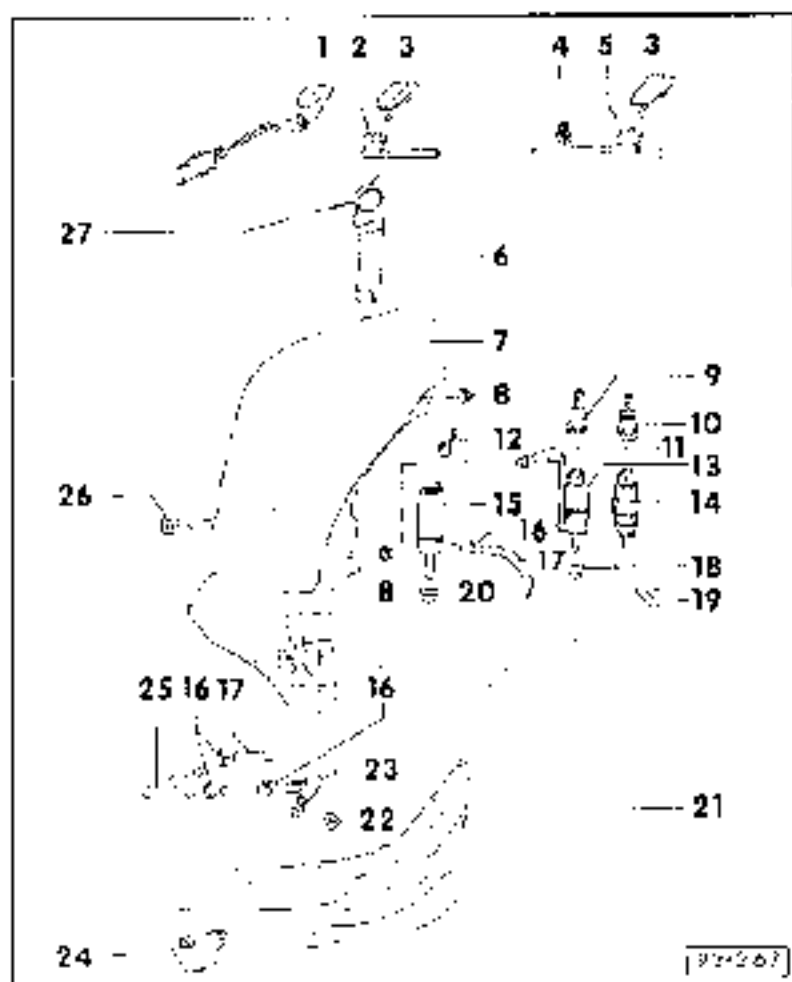

**11 - Rubber grommet**

- 12 - Connector**
- ◆ For headlight washer system pump
  - ◆ For windshield washer system in vehicles with auto-check system

- 13 - Pump**
- ◆ With integrated sensor
  - ◆ For windshield washer system in vehicles with auto-check system
  - ◆ Removing and installing -> Fig. 3 and Fig. 4

- 14 - Pump**
- ◆ For windshield washer system in vehicles with no auto-check system
  - ◆ Removing and installing -> Fig. 4

92-10

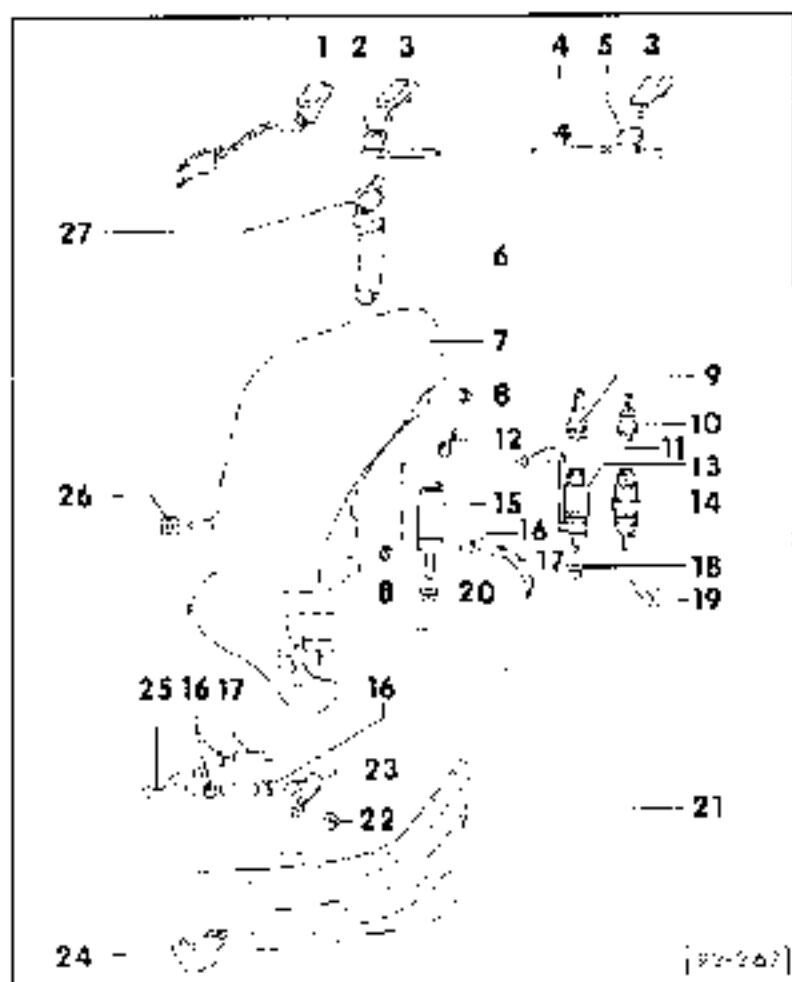

- 15 - Pump
  - ◆ For headlight washer system
  - ◆ Removal and installation, see Item 14-
- 16 - Hose clamp
  - ◆ Always replace
- 17 - Connecting hose
  - ◆ For headlight washer system
- 18 - Rubber grommet
- 19 - Angle piece
- 20 - Rubber grommet
- 21 - Bumper

92-11

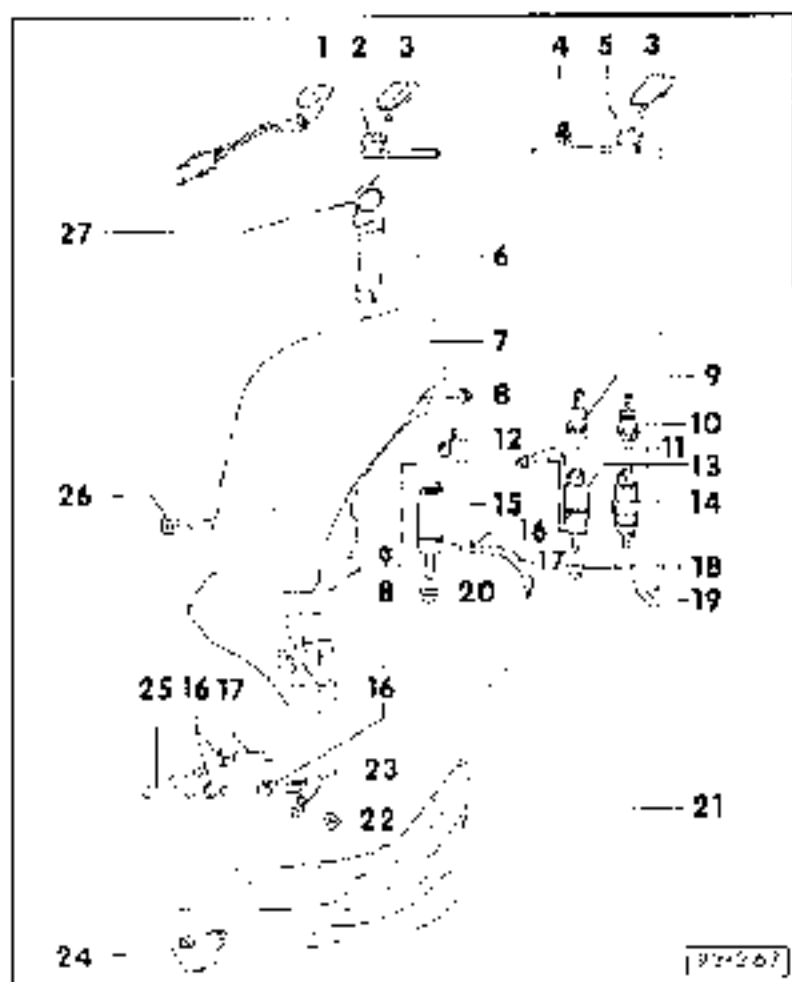

- 22 - Hexagon nut M6 2 Nm
  - ◆ Secure with sealing compound 0 000 600
- 23 - Non-return valve
- 24 - Jet and holder assembly
  - ◆ Adjusting > Fig 2
- 25 - Distributor piece
- 26 - Rubber grommet
- 27 - Cap

92-12

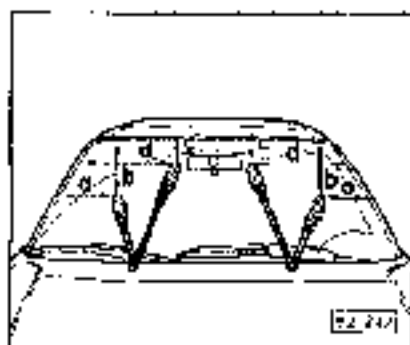

◀ Fig.1 Adjusting jets for windscreen washer system

*Notes:*

- ◆ Never use needles or other sharp objects, since these will damage the water ducts in the jet
- ◆ If the water spray is irregular or cannot be set as specified, replace jet
- Use special tool VW 3125 to set spray as follows.
  - a - 700 mm
  - b - 450 mm
  - c - 220 mm
  - d - 480 mm
- Tolerance - 20 mm

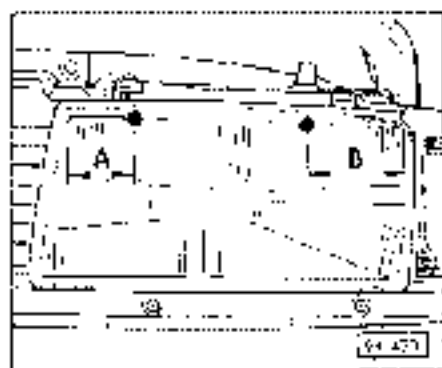

◀ Fig.2 Adjusting jets for headlight washer system

- Use special tool 3019 A to set spray at upper rim of headlight as follows
- ◆ A = 60 mm
- ◆ B = 80 mm

*Note:*

*Dimensions also apply to dual headlights*

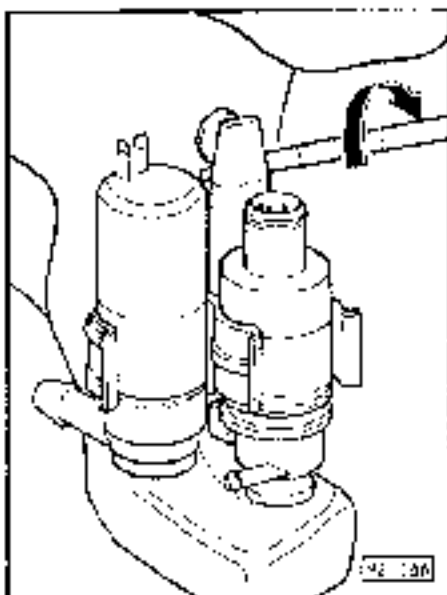

◀ Fig.3 Removing warning contact for windscreen washer system water

- Vehicles with auto-check system

Position screwdriver between reservoir and warning contact for windscreen washer system water and push warning contact out of rubber grommet by turning it



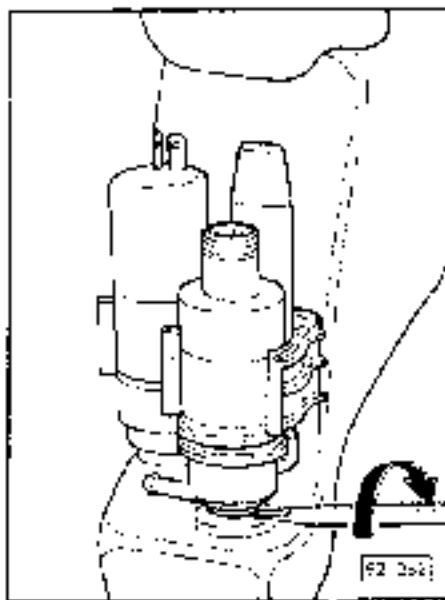

◀ Fig.4 Removing and installing pump for windscreen washer system

- Gently push pump forwards out of retaining clip
- Position screwdriver between reservoir and pump for windscreen washer system water and push pump out of rubber grommet by turning it.
- Pull pump for windscreen washer system upwards out of rubber grommet.

#### Removing and installing reservoir for windscreen and headlight washer system

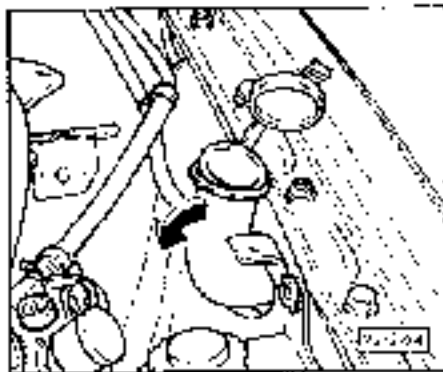

- Unscrew coolant expansion reservoir and place to one side.
- ◀ - Turn filler neck so that it is facing downwards.

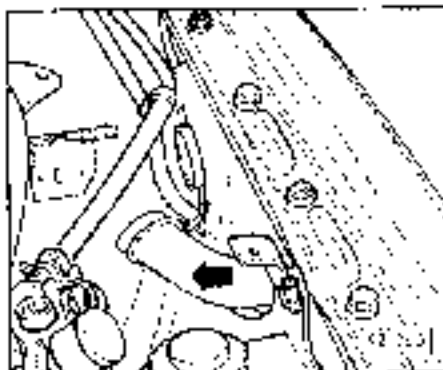

- ◀ - Pull filler neck out of mud guard lead-in and reservoir.
- Remove wheel housing liner
  - General Body Repairs; Repair Group 63; Wheel housing liners, Removing and installing front wheel housing liner - >
- Remove strut
- Pull connector and connecting hoses from washing water pumps
- Remove securing nuts (5 Nm)
- Carefully remove reservoir for windscreen and headlight washer system from wheel housing.

## Removing and installing jets for windscreen washer system

### Removal

- ◀ Remove connection sucker from jet by pulling backwards or on angle -arrow-.

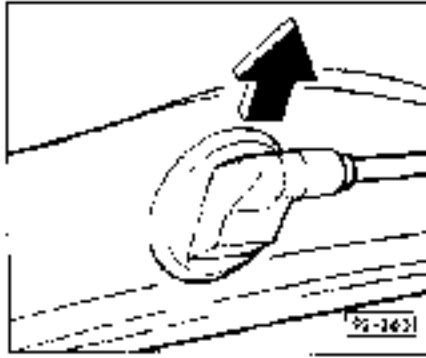

92-163

### Non-heated jets:

- ◀ - Use medium-sized angled screwdriver to press back retaining lug -arrow- whilst pressing gently on connection piece.

#### *Note:*

*Do not press screwdriver against bodywork panel.*

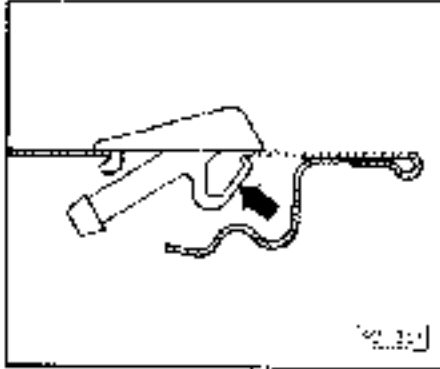

92-164

92-17

### Heated jets:

- Pull off heating connector
  - ◀ - Connector location: Behind left loan bushing in bonnet
- Use medium-sized angled screwdriver to press back retaining lug whilst pressing gently on connection piece

#### *Note:*

*Do not press screwdriver against bodywork panel.*

### All vehicles:

- Pull jet outwards out of bonnet

### Installing

- Insert jet into bonnet from outside and push home until retaining lug engages.
- Attach connection sucker.

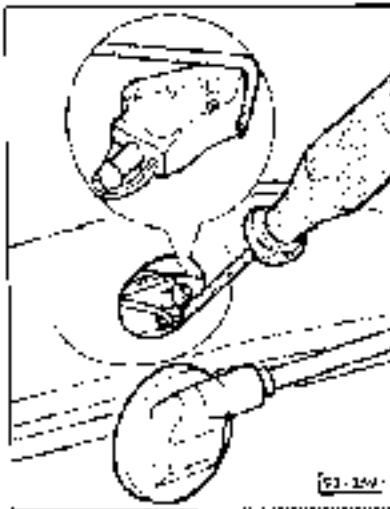

92-165

92-18

## Servicing rear window wiper system

### Removing and installing rear window wiper arm

- 1 - Rear wiper blade
- 2 - Rear wiper arm
- 3 - Cap
- 4 - Securing nut - 16 Nm
- 5 - Spring lock washer
- 6 - Securing nut - 8 Nm
- 7 - Jet for rear window washer system

**Note:**

Setting for rear window wiper blade A = 40 mm from top edge of dotted pattern.

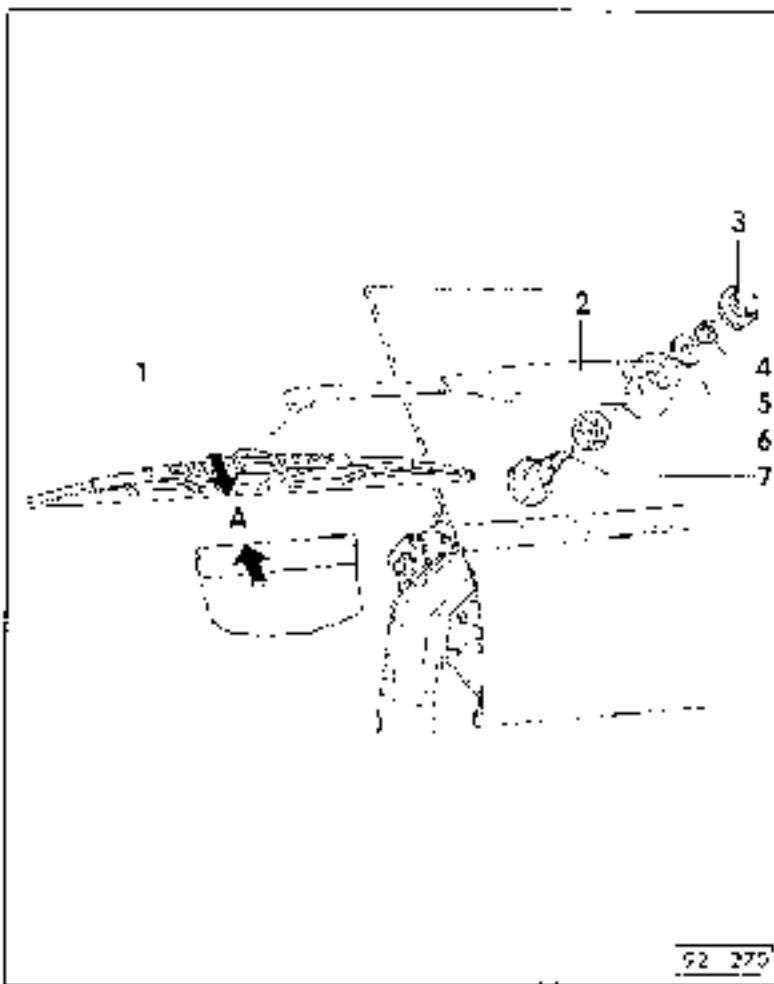

92 279

92-19

### Removing and installing rear window wiper motor

- Remove boot lid trim  
 => General Body Repairs, Mirror, Repair Group 70; Trim Panels; Removing and installing door trim (Avant) ->

- 1 - Securing screw - 8 Nm
- 2 - Securing screw - 8 Nm
- 3 - Water hose
- 4 - Metal bushing
- 5 - Jet  
 ♦ Supplied as replacement part with item 7-

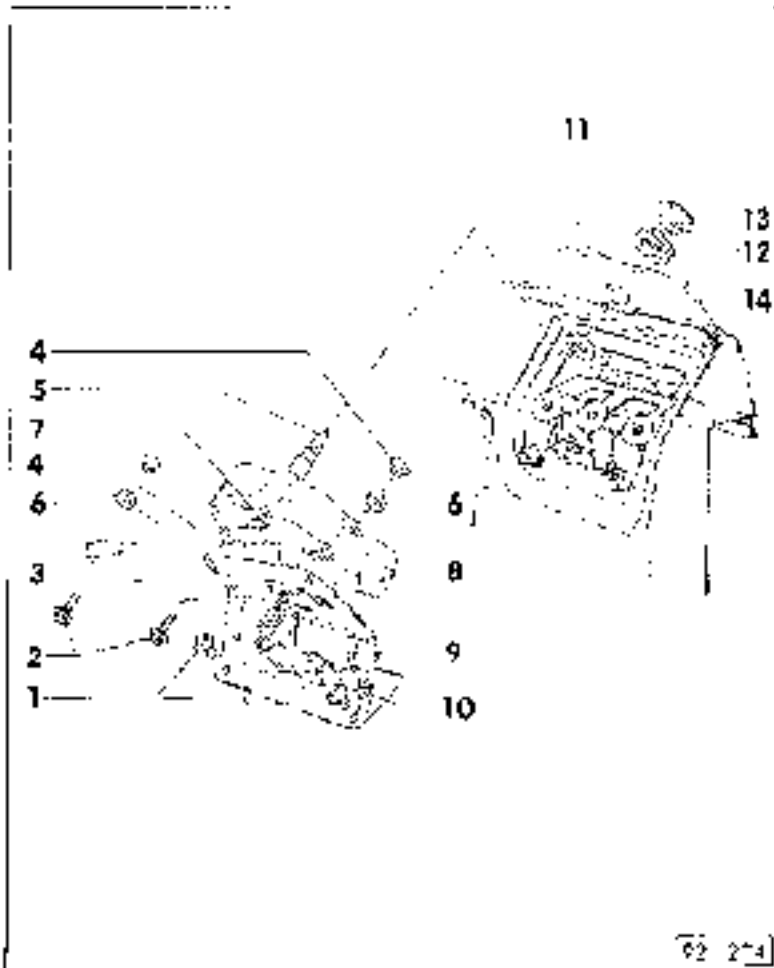

92 274

92 20



11

13

12

14

4

5

7

4

6

3

2

1

6

8

9

10

97-274

- Use universal pliers to carefully pull out connection pipe
- Pull out jet -Item 3-

#### Installing

- First fit connection pipe and then jet
- Counterhold at connection pipe when inserting jet. Connection pipe and jet must be firmly engaged

#### Adjusting jet

- Use special tool VW 312h to set spray to upper third of wiper area.

## Servicing headlights

Removing and installing headlights => Fig. 2, Page 94-6

Removing and installing fog lamps => Fig. 3, Page 94-7 / Fig. 3, Page 94-15 (dual headlights)

Adjusting fog lamps => Fig. 3, Page 94-7 / Fig. 4, Page 94-15 (Dual headlights)

Adjusting jets for headlight washer system => Fig. 1, Page 92-12

### Notes:

- ◆ Always disconnect battery earth strap before working on electrical system.
- ◆ Re-adjust headlights after carrying out work which could affect their setting => Fig. 1, Page 94-5 and => "Maintenance"

94-1

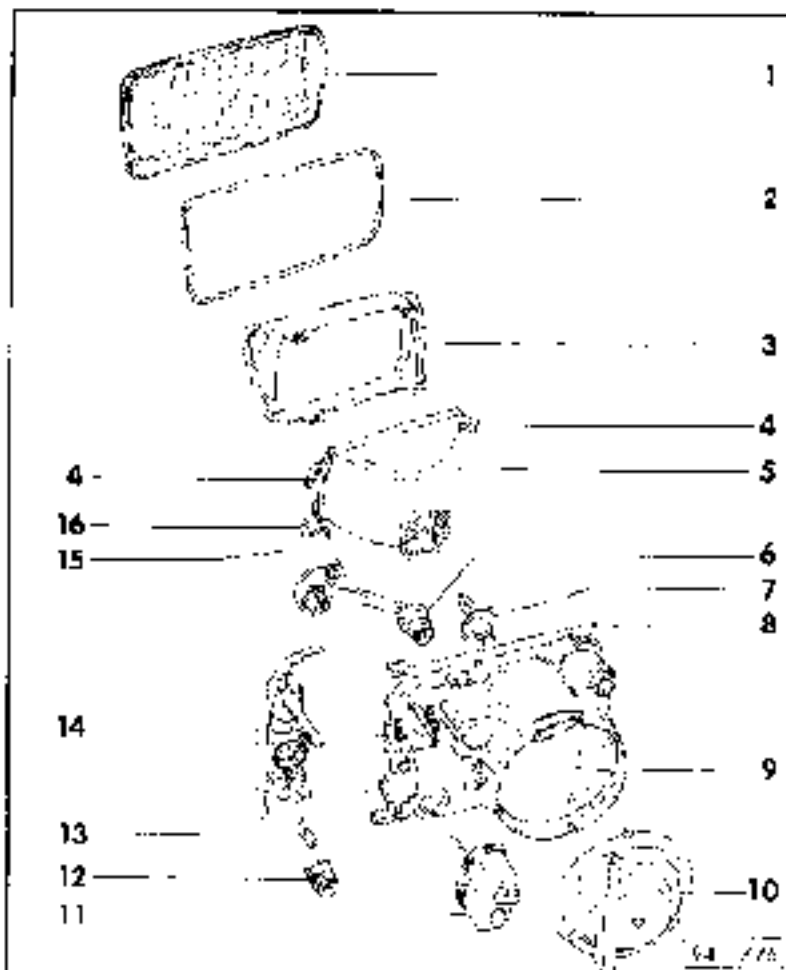

### Servicing headlights, 4- and 5-cylinder

- 1 - Lens
  - ◆ Set aside carefully
- 2 - Seal
  - ◆ Always renew
- 3 - Trim
  - ◆ Unclip
- 4 - Locating piece
  - ◆ Clipped into reflector (for headlight adjustment);
  - ◆ Different versions on left and right
- 5 - Reflector
  - ◆ Avoid touching reflective surface

94-2

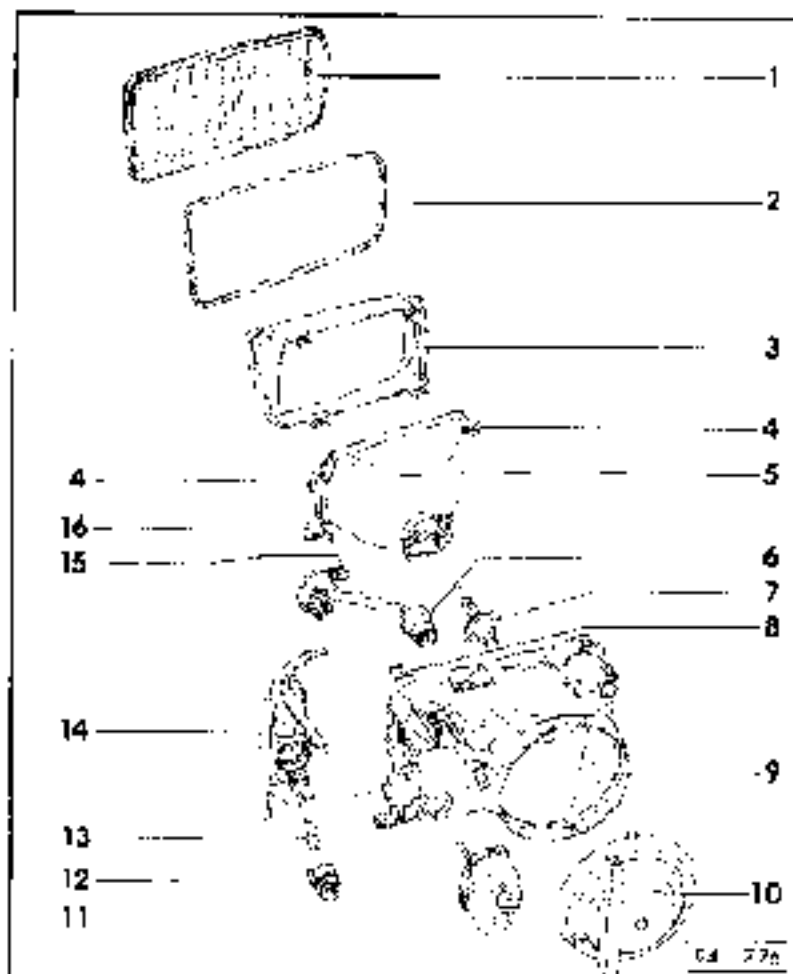

6 - Wiring loom  
 ♦ With plug housing and connector

7 - Dipped/main beam bulb  
 ♦ 12 V/50/55 W (H4)

8 - Retaining clip  
 ♦ 8x  
 ♦ Prise out carefully using screwdriver to remove  
 ♦ Press in by hand to install

9 Headlight housing

10 - Cap  
 ♦ Marking. Note bayonet fitting

94-3

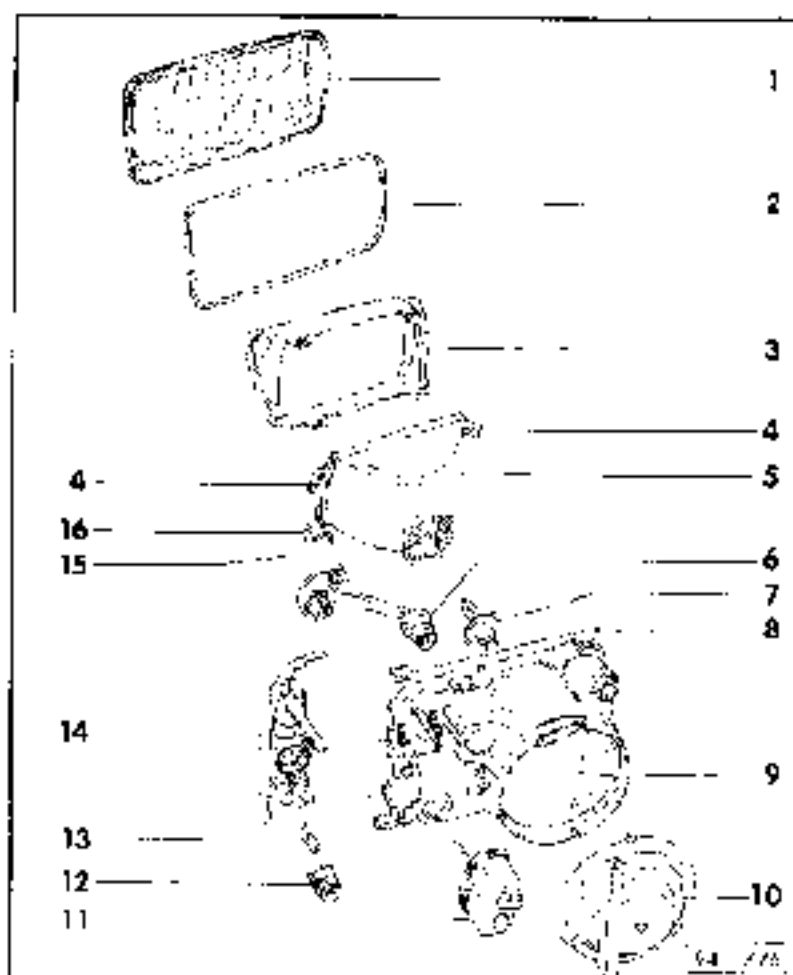

11 Control motor for headlight range adjustment system  
 ♦ For vehicles with headlight range adjustment system

12 - Socket for turn signal indicator bulb

13 Bulb for turn signal indicator  
 ♦ 12 V/21 W

14 - Turn-signal indicator  
 ♦ Removing and installing -> Fig. 4

15 Socket for side light bulb

16 - Locating piece  
 ♦ Clipped into reflector (for headlight range adjustment)

94-4

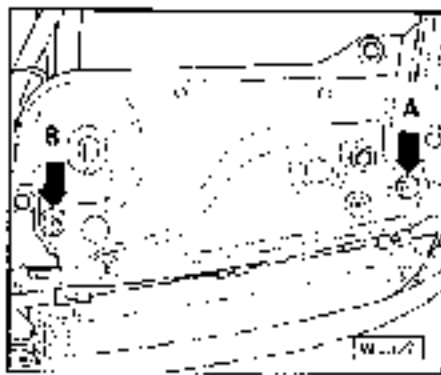

◀ **Fig.1 Adjusting headlight**

Alter headlight setting by turning adjusting screws using recessed-head screwdriver or Allen key.

- A - Height adjusting screw (towards outside of vehicle)
- B - Lateral adjusting screw (towards inside of vehicle)

**Note:**

Make the adjustment using a headlight aiming device.

- > "Maintenance"



◀ **Fig.2 Removing and installing headlight**

**Removal:**

- Disengage cap at rear (bayonet socket) and set aside.
- Removing turn signal indicator - > Fig. 4, Page 94-3.
- Remove plug.

To avoid damage, mask bumper with tape beneath headlight.

- Unscrewing trim strip beneath headlight
- > General bodywork repairs; Repair group 50; Front bodywork, Removing and installing apron - >

- Remove headlight securing bolts - arrows -
- Carefully remove headlight to front.

**Installation:**

- Insert headlight from front and align with bodywork contours: tighten the two upper securing bolts first.



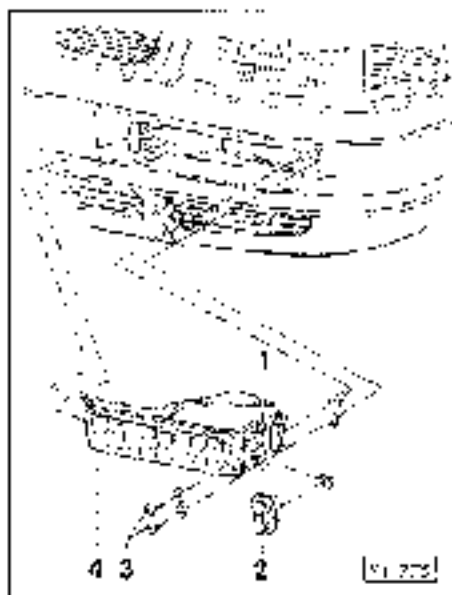

◀ Fig.3 Removing, installing and adjusting fog lamp

**Removal:**

- Loosen screw -2- and remove trim.
- Loosen screws -3-, pull fog lamp -4- out of guide and remove to front.

**Installation:**

- Insert retaining lugs in guides and secure fog lamp using screws
- Attach trim to fog lamp using screw

**Adjusting:**

- Loosen screw -2- and remove trim
- Use adjusting screw -1- to set fog lamp illumination direction to headlight adjusting device marking line.
- Attach trim to fog lamp using screw.

**Note:**

*Fog lamps cannot be laterally adjusted.*

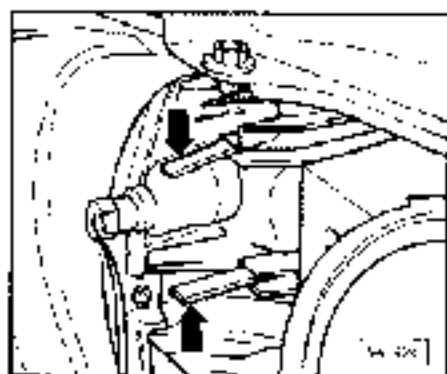

◀ Fig.4 Removing and installing turn-signal indicator

**Note:**

*Turn-signal indicator can be taken out without removing headlight*

- Push in catches -arrows- and push out turn-signal indicator to front.
- Detach connector.
- Remove turn-signal indicator

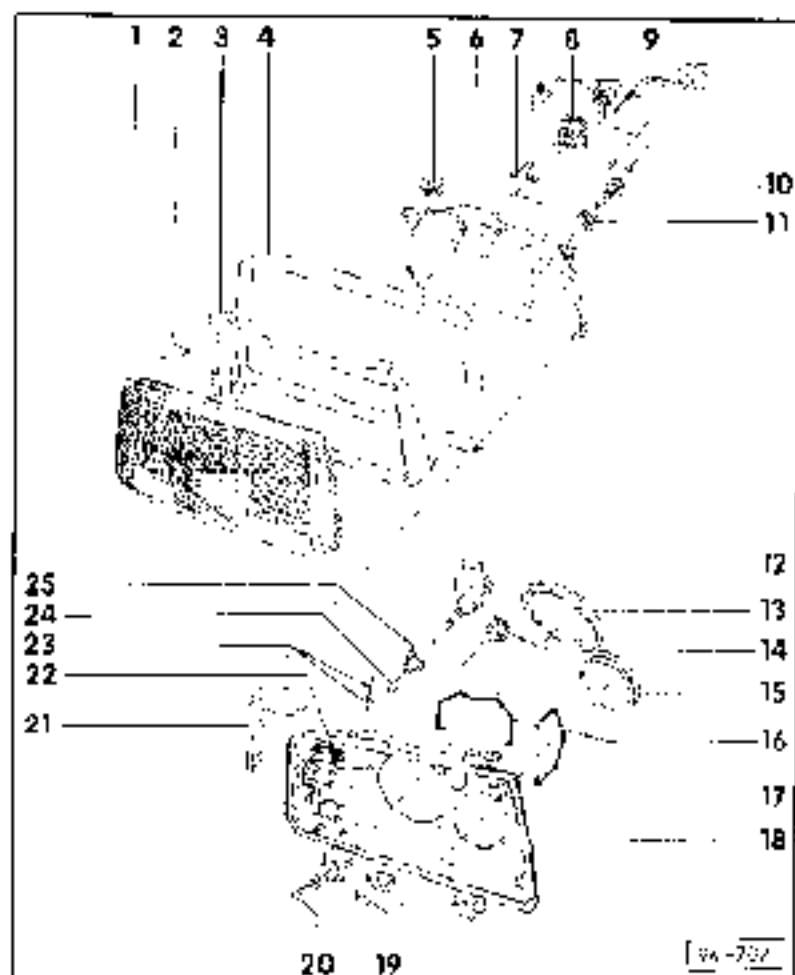

### Servicing dual headlights, 6-cylinder, S2

- 1 Lens
  - ◆ Set aside carefully
- 2 - Retaining clip
  - ◆ 8x
  - ◆ Prise out carefully using screwdriver to remove
  - ◆ Press in by hand to install
- 3 Trim
  - ◆ Unclip
- 4 - Seal
  - ◆ Always renew
- 5 - Locating piece
  - ◆ Clipped into reflector

94-9

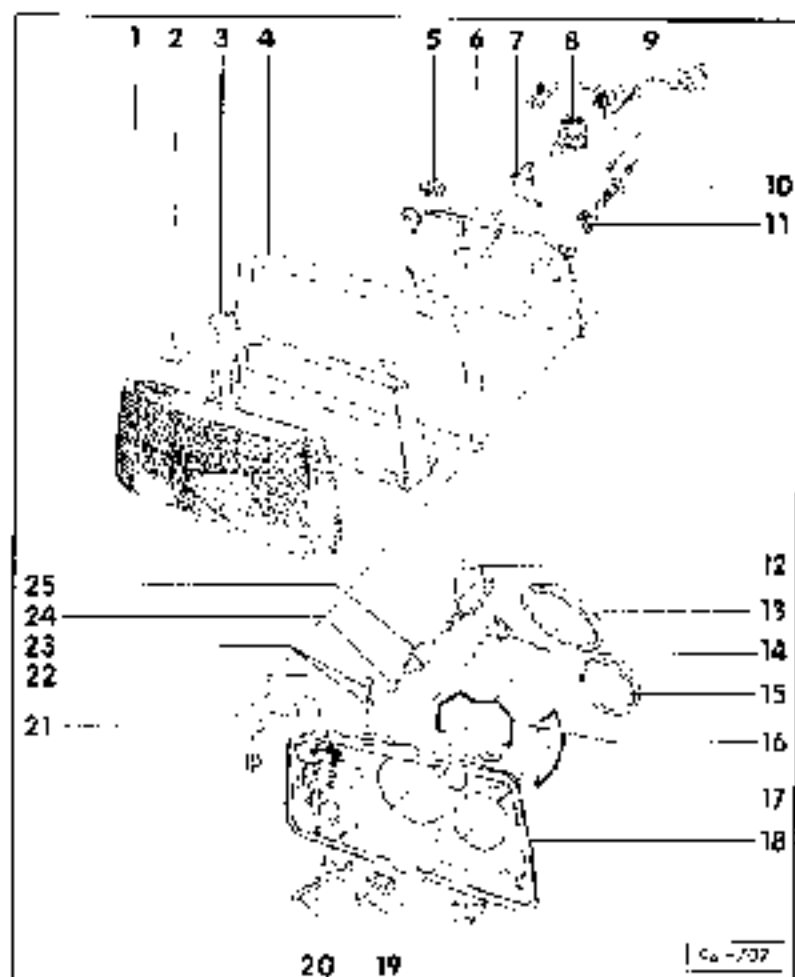

- 6 Reflector
  - ◆ Avoid touching reflective surface
- 7 - Retaining clip for bulb (H4)
  - ◆ Push off by hand
- 8 Dipped/main beam bulb
  - ◆ 12 V/80/55 W (H4)
- 9 - Wiring loom
  - ◆ With plug housing and connector
- 10 Bulb for main beam
  - ◆ 12 V/55 W (H1)
- 11 - Locating piece
  - ◆ Clipped into reflector

94 10

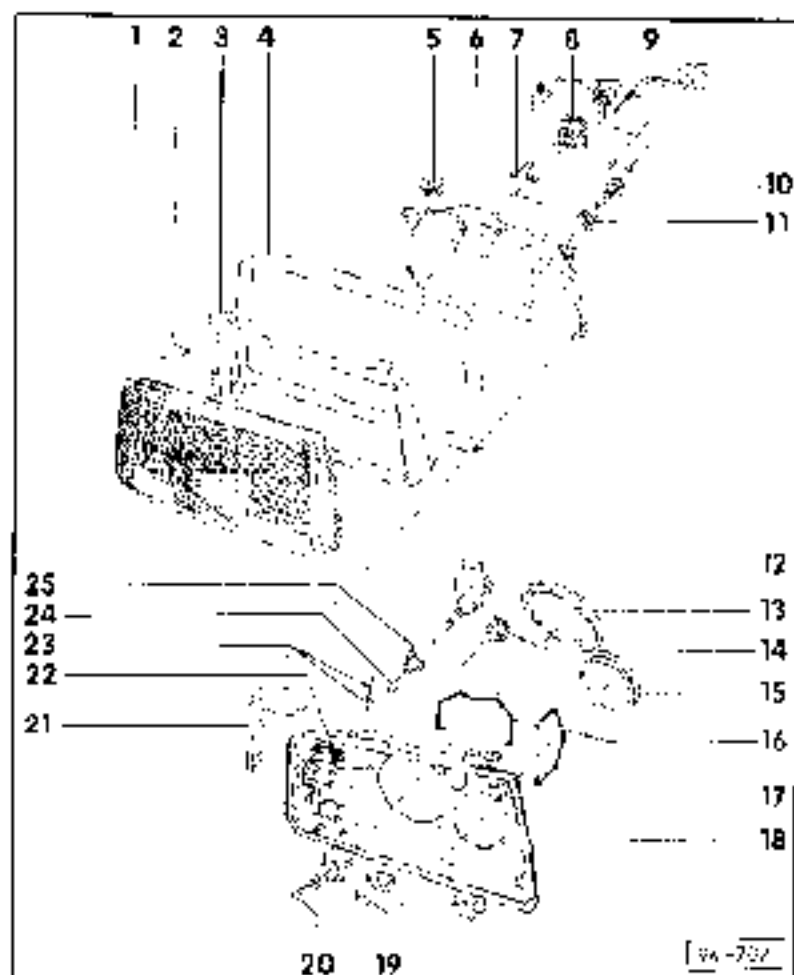

- 12 - Control motor for headlight range adjustment system
  - ◆ For vehicles with headlight range adjustment system
- 13 - Cap (large)
- 14 - Locating piece for reflector
  - ◆ Only for vehicles without headlight range adjustment system
  - ◆ Right - release anti-clockwise
  - ◆ Left - release clockwise
- 15 - Cap (small)
- 16 - Wire clip
  - ◆ Prise off or push off by hand

94-11

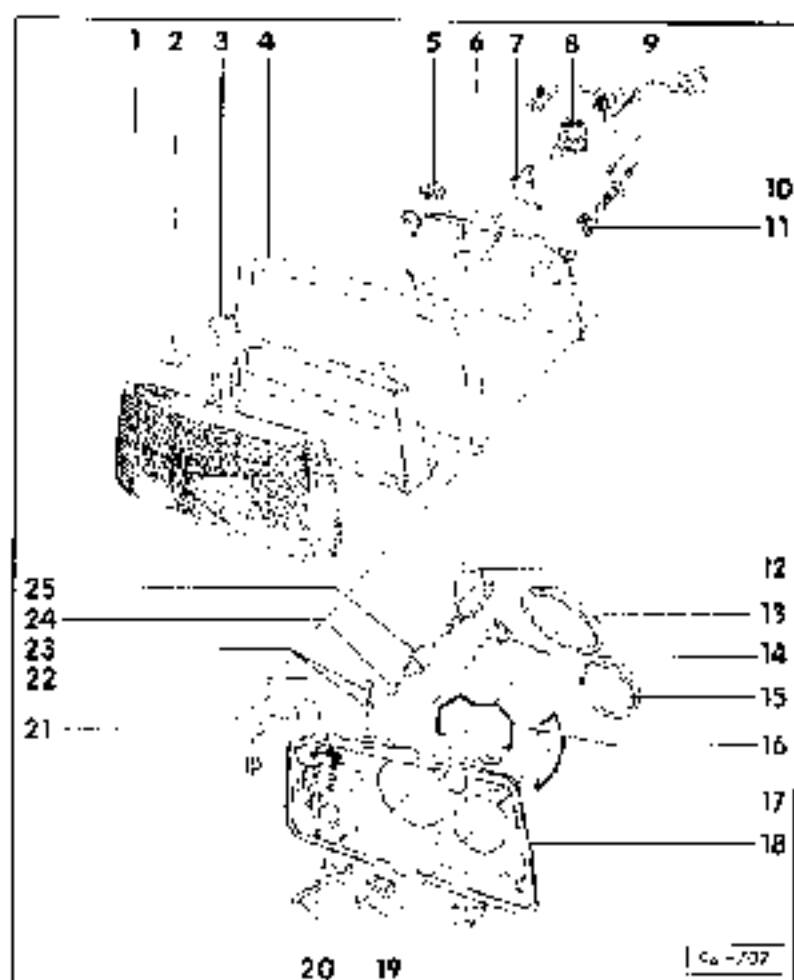

- 17 - Lateral adjustment screw
  - ◆ Flexibly mounted in housing
  - ◆ Adjusting headlight - > Fig. 1, Page 94-13
- 18 - Headlight housing
  - ◆ Removing and installing headlight - > Fig. 1.
- 19 - Fastener
  - ◆ Clipped into headlight housing
- 20 - Fastening screw
  - ◆ With washer
- 21 - Rest
  - ◆ Bonded to housing
  - ◆ Must make flush contact

94-12

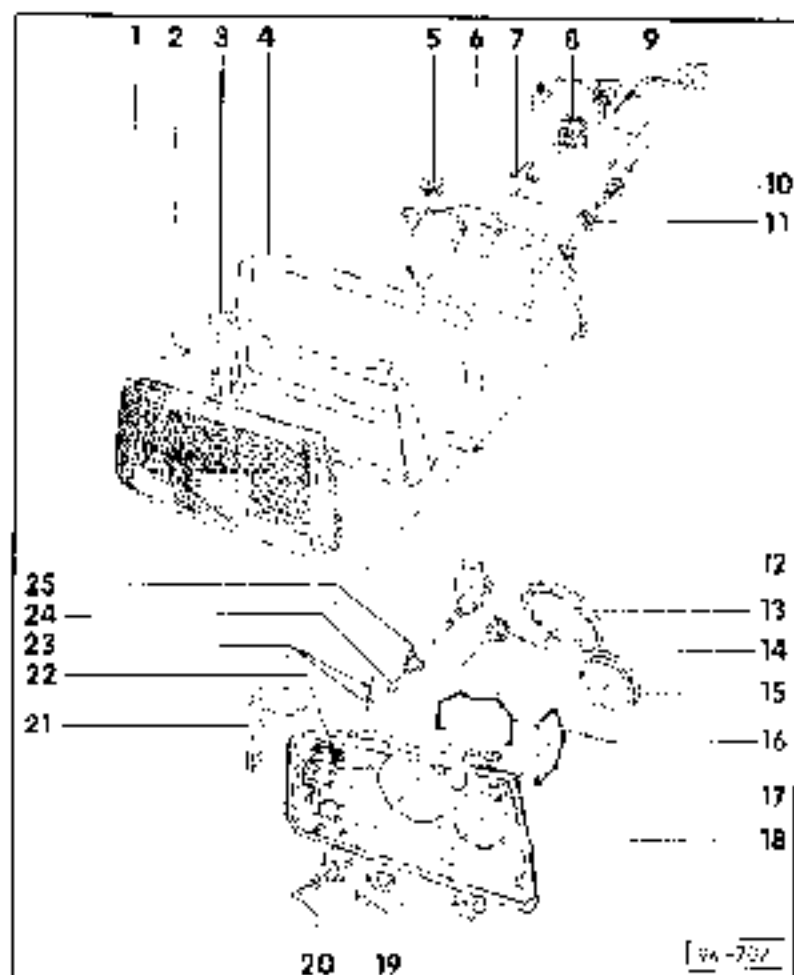

- 22 - Height adjustment screw
  - ◆ Flexibly mounted in housing
  - ◆ Adjusting headlight -> Fig. 1, Page 94-13.
- 23 - Fastening screw
  - ◆ With washer
- 24 - Side light bulb
  - ◆ 12 V; h W (incandescent lamp)
- 25 - Socket for side light bulb

94-13

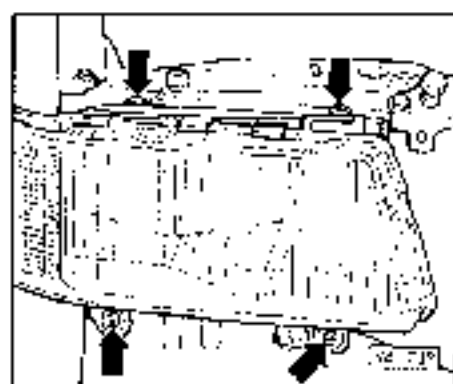

◀ Fig.1 Removing and installing headlight

**Removal:**

- Remove plug.
- To avoid damage, mask bumper with tape beneath headlight.
- Unscrewing trim strip beneath headlight
  - > General bodywork repairs; Repair group 50: Front bodywork: Removing and installing apron ->
- Remove headlight securing bolts - arrows -
- Carefully remove headlight to front.

**Installation:**

- Insert headlight from front and align with bodywork contours: tighten the two upper securing bolts first.

◀ Fig.2 Removing and installing turn-signal indicator

Loosen screw (arrow) and remove turn signal to front.

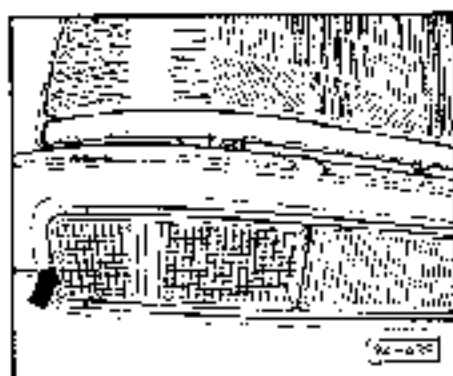

94-14

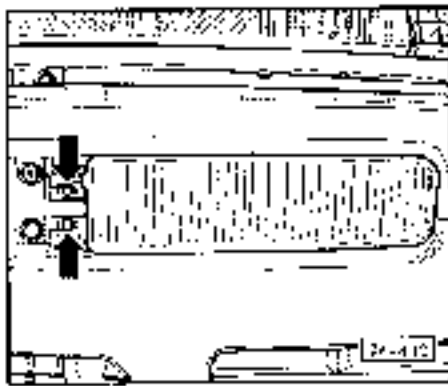

◀ Fig.3 Removing and installing fog lamp

- Removing turn signal indicator → Fig. 2
- Loosen both screws -arrow- and remove fog lamp to front.

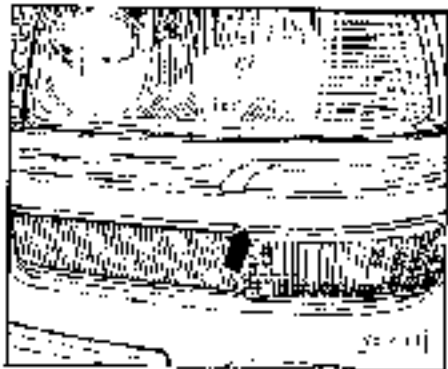

◀ Fig.4 Adjusting fog lamp

Use adjusting screw -arrow- to set fog lamp illumination direction to headlight adjusting device marking line.

**Notes:**

- ◆ Adjustment can be made without removing turn signal indicator.
- ◆ Fog lamps cannot be laterally adjusted.

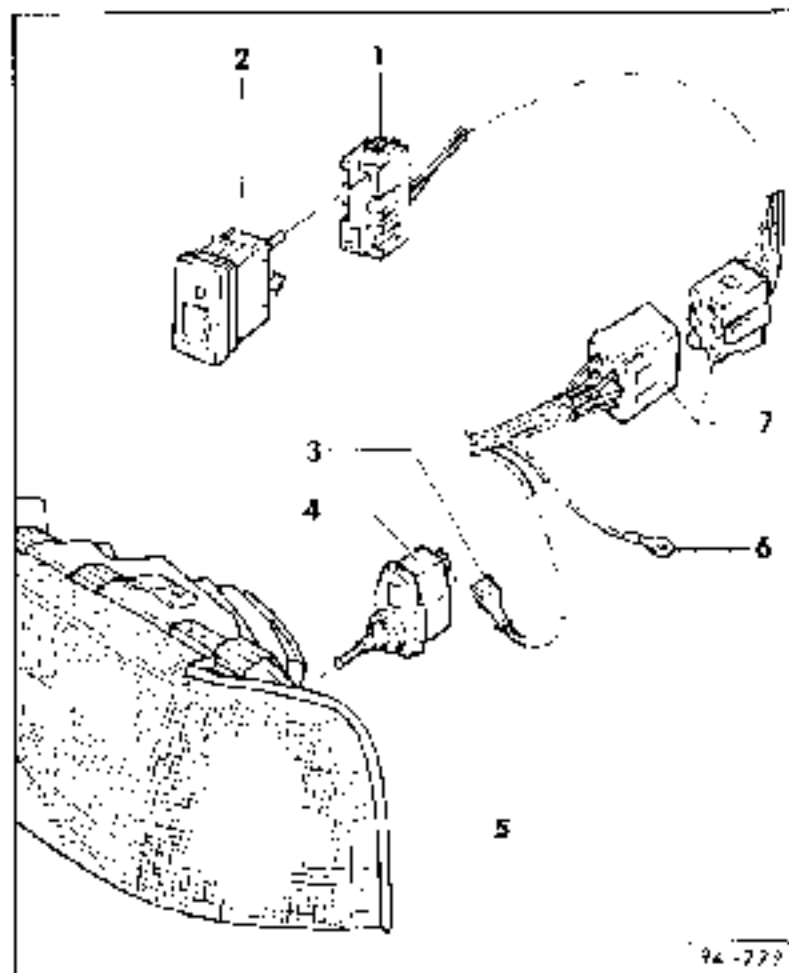

**Servicing electrical headlight range adjustment**

**Note:**

*Troubleshooting/Servicing*

> "Current Flow Diagrams, Electrical Fault Finding and Fitting Locations" binder

- 1 Connector
  - ◆ For headlight range control adjuster
  - ◆ At instrument panel wiring loom
- 2 - Headlight range control adjuster (potentiometer) - E102
  - ◆ Installed in centre console
  - ◆ Carefully prise off using screwdriver

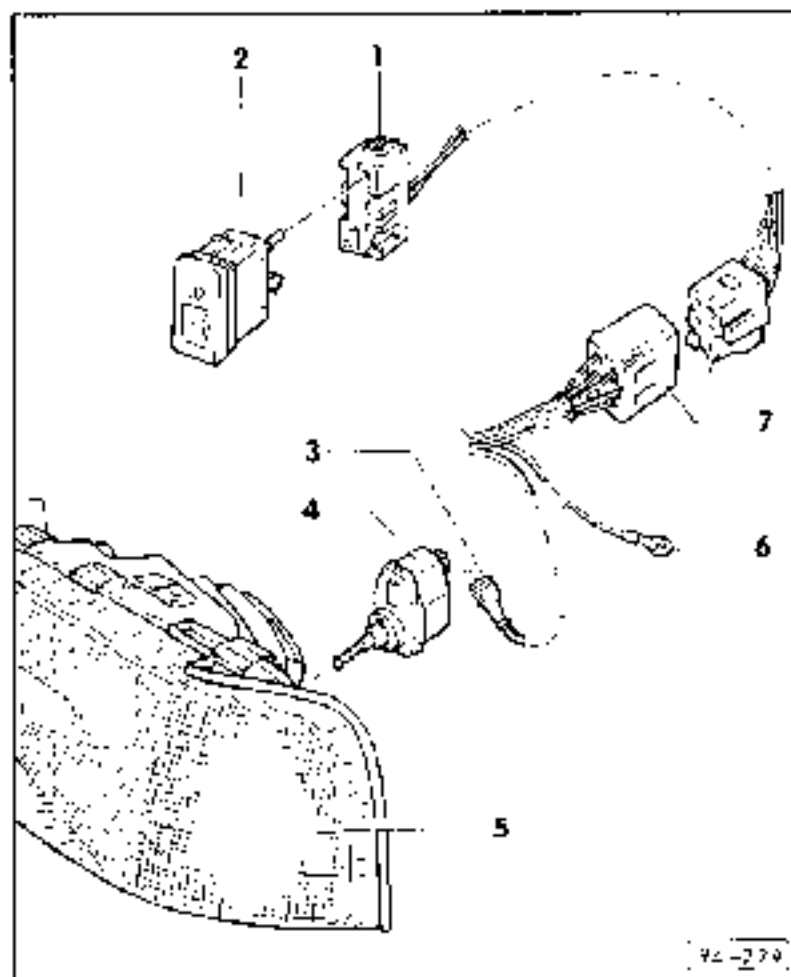

**3 - Connector for control motor**  
 ◆ Cavity assignment  
 > "Current Flow Diagrams, Electrical Fault Finding and Fitting Locations" binder

**4 - Control motor -V48, -V49**  
 ◆ Removing and installing => Page 94-19  
 ◆ Removing and installing dual headlights => Page 94-21

**5 - Headlight housing**  
 ◆ Remove to take out control motor  
 ◆ Removing and installing => Fig. 2, Page 94-8

94-17

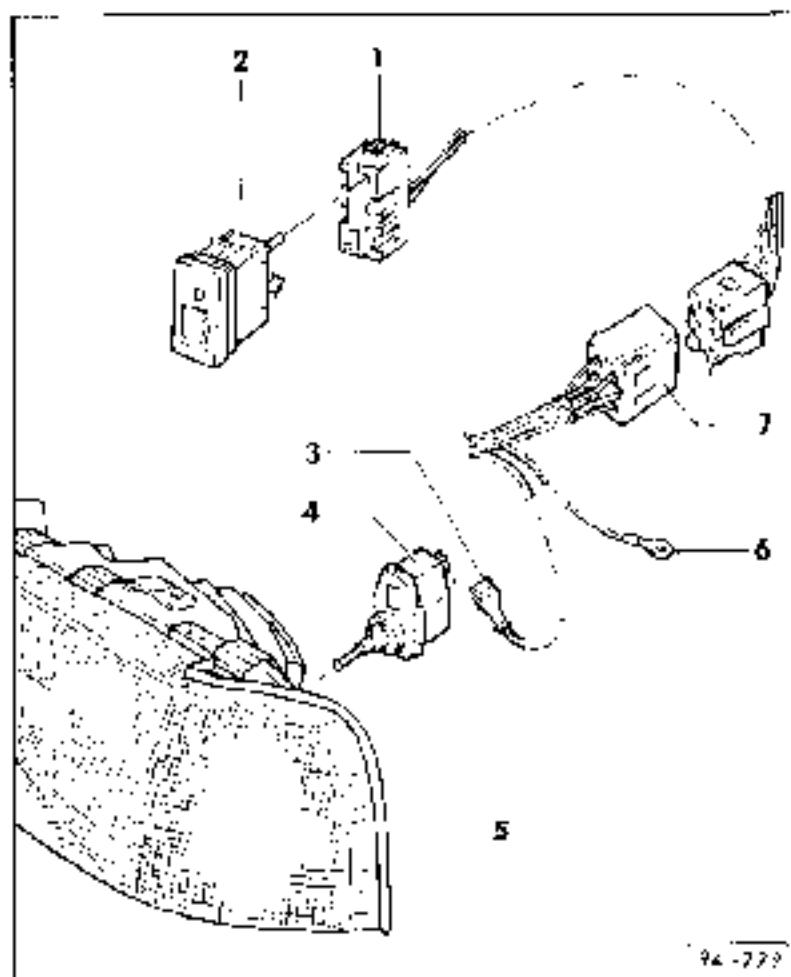

◆ Removing and installing dual headlights => Fig. 1, Page 94-18  
 ◆ Adjusting headlight => Fig. 1, Page 94-5.

**6 - Earthing point**

**7 - Connector**  
 ◆ Instrument panel/headlight range adjustment wiring loom

94-18

## Removing and installing control motor

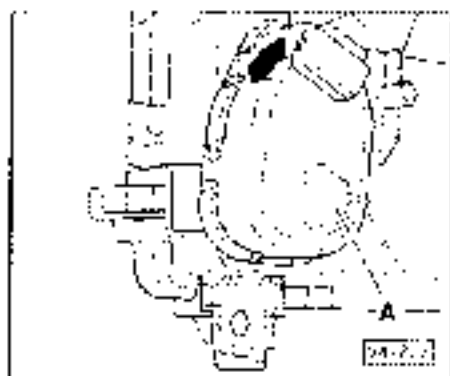

### Removal:

- Removing headlight => Fig. 2, Page 94 C.
- Release control motor -A- from support frame:
  - Turn control motor anticlockwise for left headlight.
  - Turn control motor clockwise for right headlight.

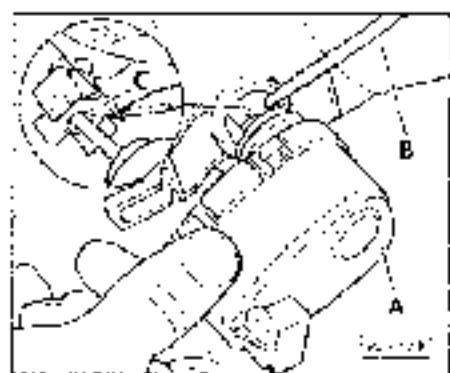

- Lift up control motor -A- and insert narrow screwdriver -B- through rear headlight opening.
- Press back catch -C- and simultaneously pull out control motor to rear.

94-19

### Installation:

- Release cap for two-filament lamp and remove.  
Push reflector upwards over twin filament lamp into it, insert operating arm with ball-head into reflector ball head mount and push in.

### Note:

*Avoid contact with inside of reflector.*

- Lock control motor in position
- Installing headlight => Fig. 2, Page 94 d.

94-20

## Removing and installing dual headlight control motor

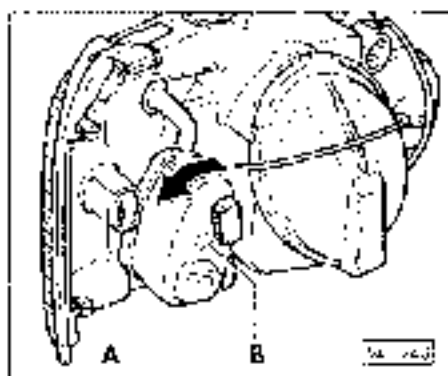

### Removal:

- Removing headlight => Fig. 1, Page 94 11.
- Remove side light socket -A-.
- Release control motor -B- from support frame:
  - Turn control motor anticlockwise for left headlight
  - Turn control motor clockwise for right headlight

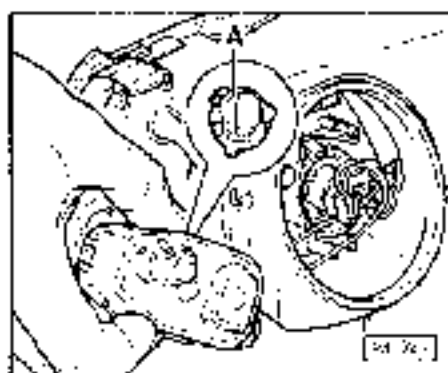

- Lift up control motor and push operating arm upwards out of ball-head mount-A- by tilting control motor.
- Pull out control motor to rear.

94-21

### Installation:

- Release cap for two-filament lamp and remove.  
Push reflector upwards over twin filament lamp into it, insert operating arm with ball-head into reflector ball head mount and push in.

### Note:

*Avoid contact with inside of reflector.*

- Lock control motor in position
- Installing headlight => Fig. 1, Page 94 14.

94 22



## Servicing tail light

### Note:

If a fog lamp is retrofitted, the relevant bulb holder and associated clear cover must also be retrofitted. Do not retrofit the fog lamp in the old clear cover.

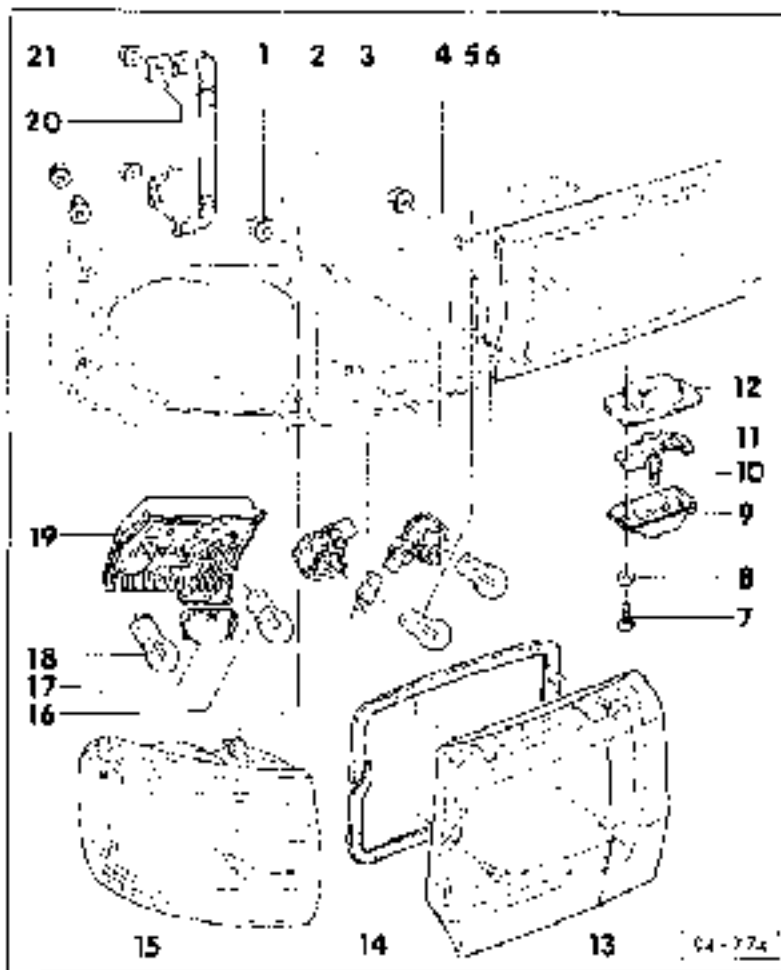

- 1 - Combination nut M5, 4 Nm
- 2 - Bulb holder for rear fog lamp
  - ◆ Removing and installing - > Fig. 2
- 3 - Connector with wiring loom
- 4 - Bulb holder for reversing light
  - ◆ Removing and installing - > Fig. 2

94-23

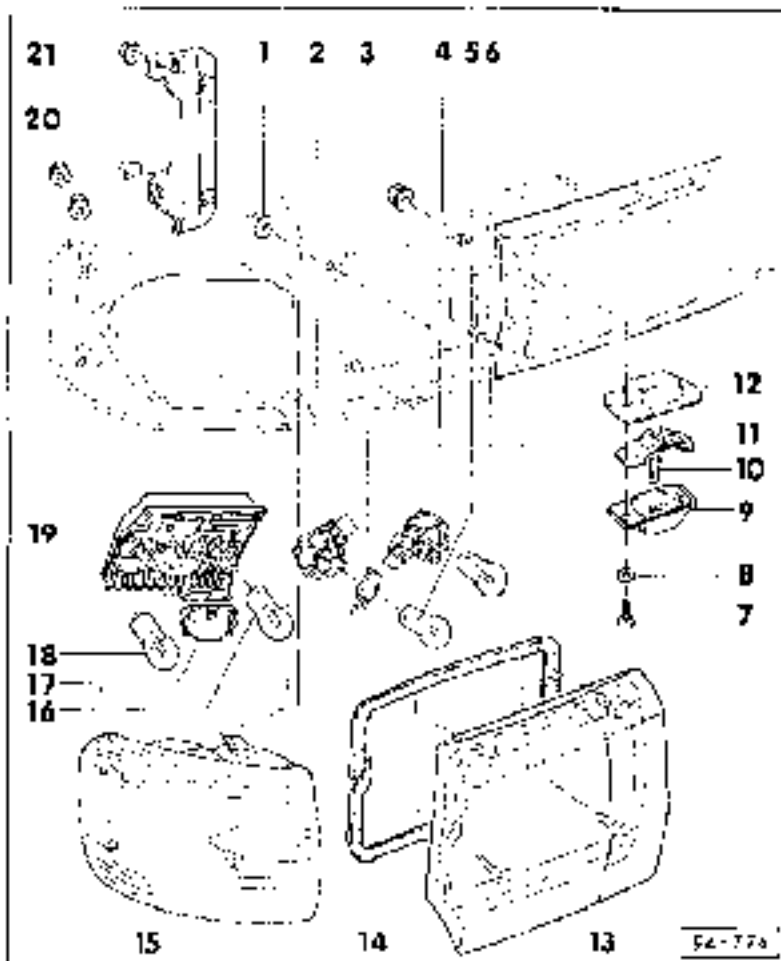

- 5 - Bulb for rear fog lamp
  - ◆ 12 V/21 W
- 6 - Bulb for reversing light
  - ◆ 12 V/21 W
- 7 - Self-tapping screw
- 8 - Seal
- 9 - Clear cover for number plate light
- 10 - Bulb for number plate light
  - ◆ 12 V/4 W
- 11 - Bulb holder for number plate light

94-24

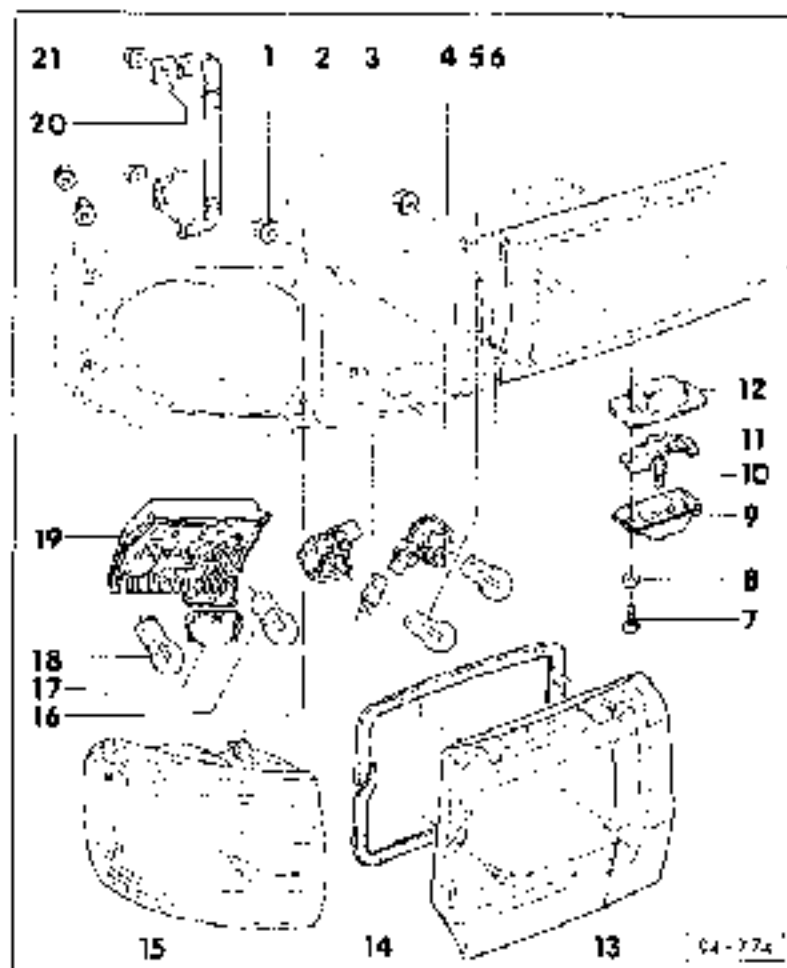

- 12 - Rubber seal
- 13 - Clear cover for reversing light and rear fog lamp
- 14 - Gasket
  - ◆ Always renew
- 15 - Clear cover for brake light, reversing light and turn-signal indicator
- 16 - Bulb for brake light and reversing light
  - ◆ 12 V/21/5 W
- 17 - Connector with wiring loom
- 18 - Bulb for turn signal indicator
  - ◆ 12 V/21 W

94-25

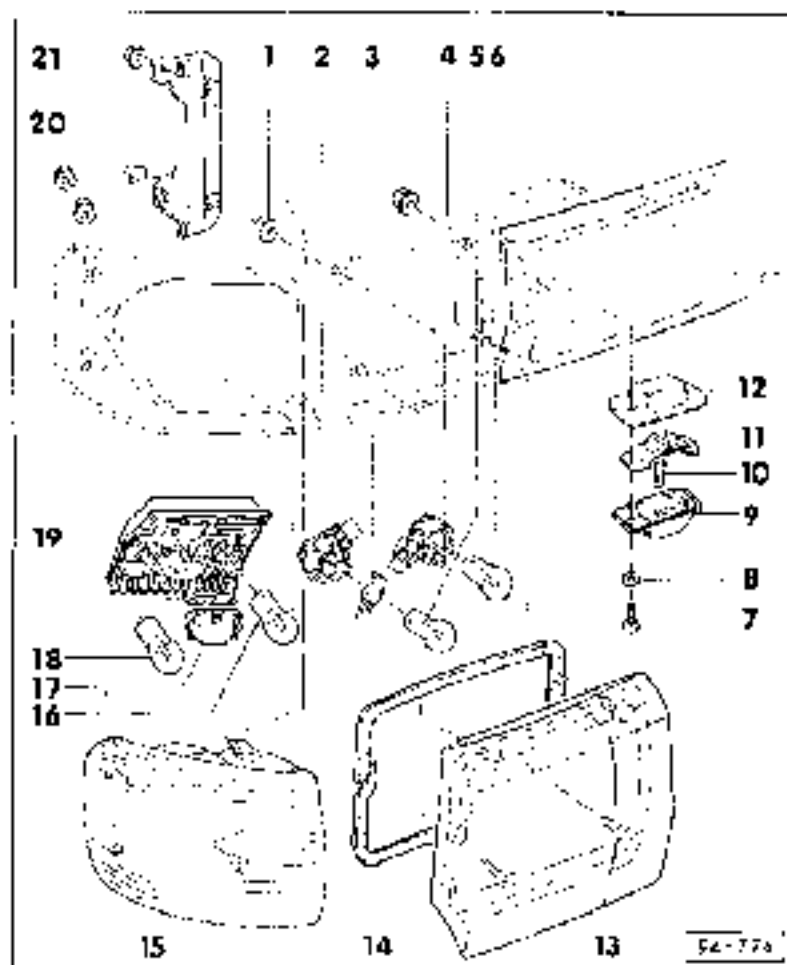

- 19 - Bulb holder for brake light, reversing light and turn-signal indicator
  - ◆ Removing and installing -> Fig. 1
- 20 - Bracket for tail light
- 21 - Combination nut M5, 4 Nm

94-26

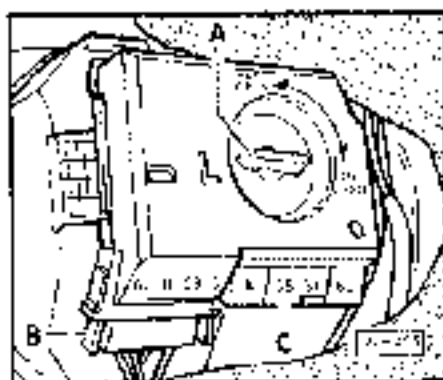

◀ Fig.1 Removing and installing bulb holder for brake light, reversing light and turn signal indicator

- Turn catch -A- in direction of arrow.
- Pull off connector -B- and remove bulb holder.

*Note:*

*Use connections -C- when retrofitting towing hitch.*

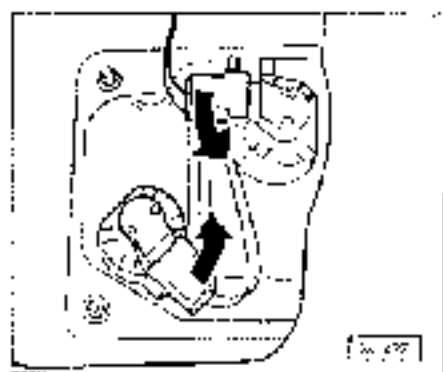

◀ Fig.2 Removing and installing bulb holder for reversing light and rear fog lamp

- Turn bulb holder in direction of arrow and pull out

## Removing and installing steering column switch

### Removal

*Note:*

*Establish radio security code before disconnecting battery.*

**Vehicles without airbag:**

- Detach battery earthing strap
- Pull off steering wheel cover by hand
  - Pull firmly on top half of cover to carefully detach it from mounting points; then remove bottom half using same procedure.
  - Push cover to one side and remove
- Detach connector

## Vehicles with airbag

Pay attention to safety instructions

General airbag safety instructions

= > Chassis assembly work: Repair group 69: General safety instructions - >

### ● 1. Operation: Disconnect voltage supply

Vehicles > 06.95: Detach battery parking strap

- Vehicles > 08.92: Remove compartment on driver's side.

> General body repairs; Repair group 70: Dash panel, Removing driver's storage compartment - >

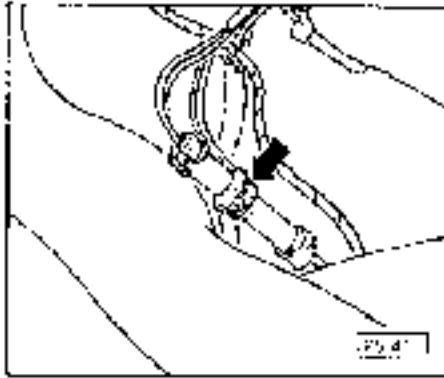

- ◀ - Detach 1-pin connector (red) for airbag power supply behind driver's side tray.

94-29

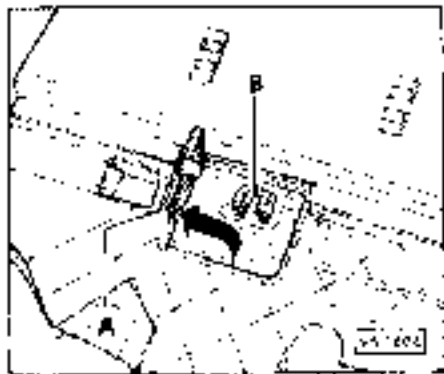

- ◀ - Vehicles 10.92 > 06.95: Open cover in driver's side tray - arrow A.
- Remove 1-pin connector (red) for power supply from holder -B- and detach connector.

### Note:

*The 1-pin connector for the airbag power supply was discontinued as of model year 1996.*

- Vehicles 07.93 >: Disconnect battery and cover negative terminal.

### ● 2. Operation: Remove airbag

- ◀ Unscrew airbag unit on left and right of steering wheel from back of steering wheel using TORX insert T30.
- Carefully fold back airbag unit

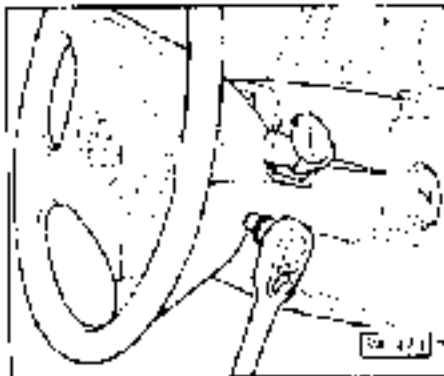

94-30

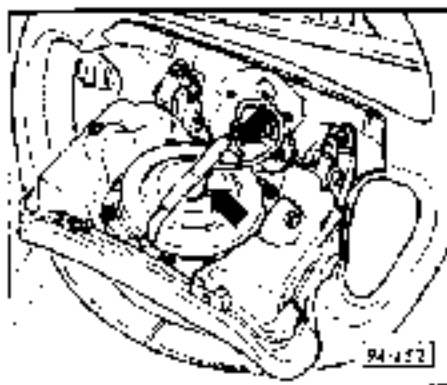

- ◀ - Detach airbag unit plug securing clip-top -arrow-.  
Disconnect plug from airbag unit -bottom arrow- and remove airbag unit.

*Note:*

*Set down airbag unit with impact cushion facing upwards.*

- Move wheels to straightahead position to avoid damaging valve spring in steering wheel.

● 3 Operation: Detaching connector for valve spring

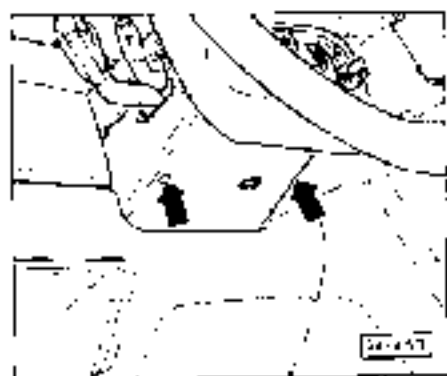

- ◀ Remove the two screws -arrows- in the steering column switch upper trim.

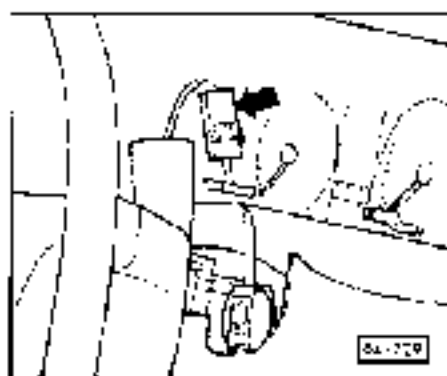

- ◀ - Vehicles > 08.93. Detach connector -arrow-.

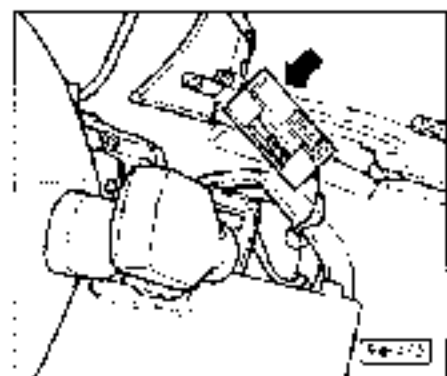

- ◀ Vehicles 07.93 > - Pull airbag unit lead connector out of lower trim, gently pushing in lug in centre of lower connector section using a screwdriver and removing.
- Detach connector -arrow-.

**All vehicles:**

**Notes:**

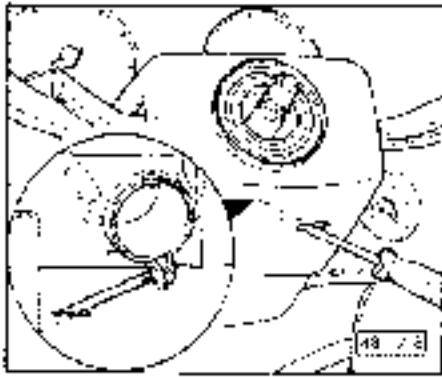

- ◆ Ensure that wheels are in a straightahead position before removing steering wheel
- ◆ Prior to removal, it may be advisable to put a mark on the steering wheel and steering column using a felt-tipped pen so that the correct steering wheel position can be quickly and easily found during installation
- Loosen securing nut on steering column and remove steering wheel (40 Nm)
- Loosen recessed-head screw for steering column switch clamp on underside.

**Notes:**

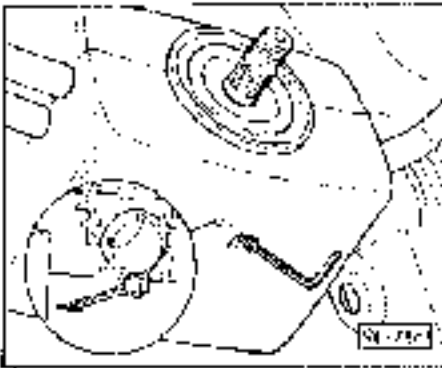

- ◆ The steering column switch clamp fastening screw has been changed from a recessed-head screw to a hexagon socket-head bolt (gradual introduction).
- ◆ Turn Allen key carefully to avoid scratching steering column switch trim
- Loosen bolt for steering column switch clamp on underside using 4 mm Allen key (2.5 Nm).

94-33

- Remove all connector from steering column switch
- Carefully remove steering column switch.

**Installing**

**Note:**

*When mounting steering wheel, turn-signal stalk must be in zero position (driving straightahead) to avoid damaging the reset cam.*

**Vehicles with airbag.**

- On installation, first screw in airbag unit securing bolts by hand
- Tighten right-hand bolt to 6 Nm, then tighten left-hand bolt to 6 Nm
- Connect battery.

**Warning**

There must be no one in the vehicle when the battery is being connected.

94-34

## Servicing steering column switch

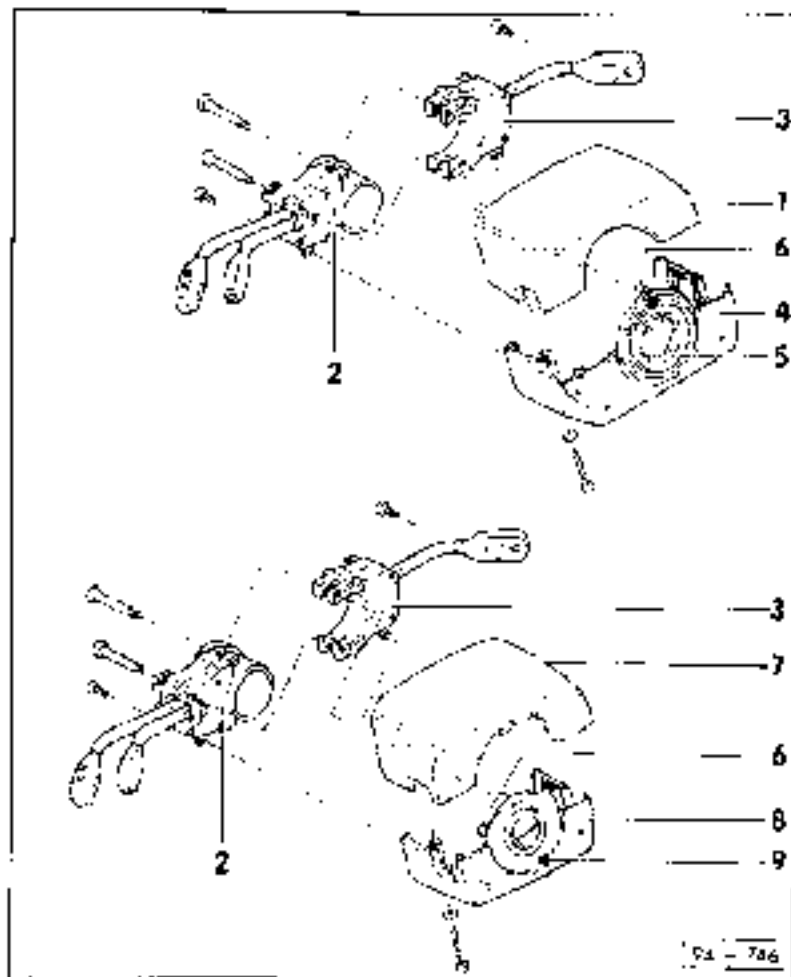

- 1 - Upper trim
  - ◆ For vehicles without airbag.
- 2 - Left switch
  - ◆ Light switch, turn-signal indicator switch, switch for manual dipping and headlight flasher, parking light and cruise control system
  - ◆ Connection assignment -> Fig. 1, Fig. 2 and Fig. 2
- 3 - Right switch
  - ◆ Windscreen wiper switch, headlight washer system and on-board computer
  - ◆ Connection assignment -> Fig. 4, Fig. 5 and Fig. 6

94-35

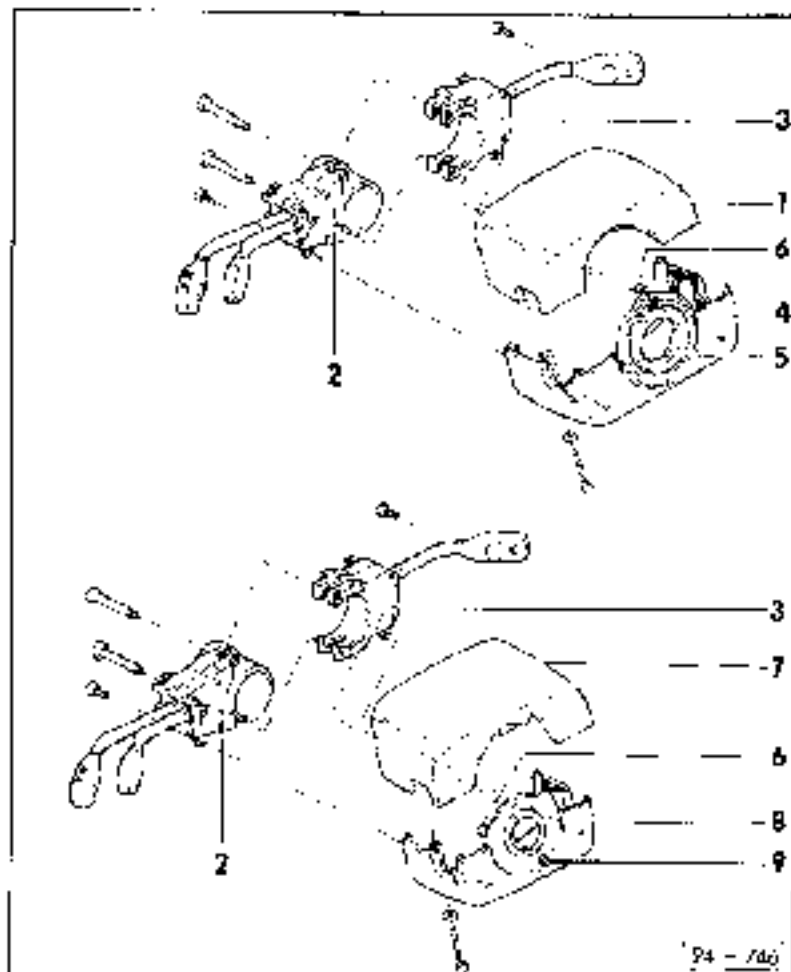

- 4 - Lower trim
  - ◆ For vehicles without airbag.
- 5 - Collector ring
  - ◆ Horn actuation
- 6 - Contact
  - ◆ For collector ring
  - ◆ Routing of wiring
  - > "Current Flow Diagrams, Electrical Fault Finding and Fitting Locations" Index
- 7 - Upper trim
  - ◆ For vehicles with airbag
- 8 - Lower trim
  - ◆ For vehicles with airbag
- 9 - Carbon brush
  - ◆ For vehicles with airbag

94 36

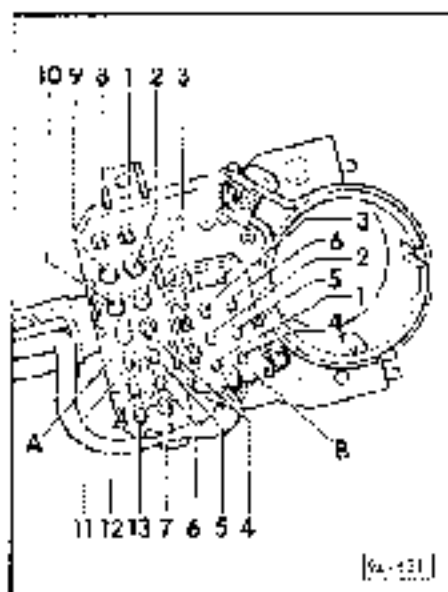

◀ Fig. 1 Connection assignment for light switch, turn-signal indicator switch, switch for manual dipping and headlamp flasher, parking light and cruise control system

*Notes:*

- ◆ Assignment of 13-pin connector -A- -> Fig. 2
- ◆ Assignment of 6-pin connector -B- -> Fig. 3.

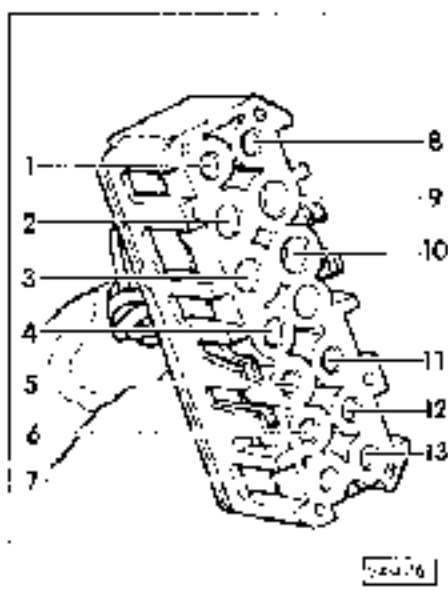

◀ Fig. 2 13-pin connector -A-

- 1 - Light switch, contact 1 (daytime/urban driving)
- 2 - Switch for manual dipping and headlight flasher, terminal 56a
- 3 - Light switch, terminal X
- 4 - Parking light switch, terminal PK
- 5 - Parking light switch, terminal PL
- 6 - Light switch and switch for manual dipping and headlamp flasher, terminal 30
- 7 - Switch for manual dipping and headlamp flasher, terminal 56b
- 8 - Switch for manual dipping and headlamp flasher, terminal 55
- 9 - Light switch, contact 9 (daytime/urban driving)
- 10 - Light switch, contact 10 (daytime/urban driving)
- 11 - Parking light switch, terminal P
- 12 - Light switch and switch for manual dipping and headlamp flasher, terminal 30
- 13 - Light switch, terminal 55



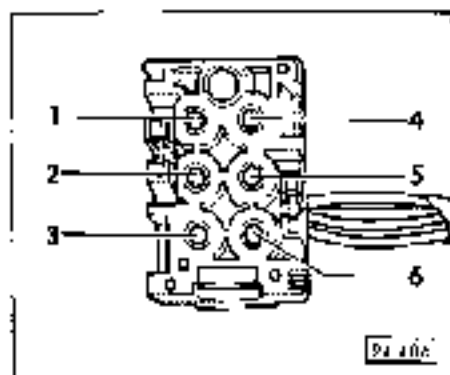

◀ Fig. 3 6-pin connector -B-, cruise control system

- 1 Terminal 15
- 2 - On, activation and off (key-operated)
- 3 - Input from control unit, contact 3
- 4 - Switch-on and activation
- 5 - Activation
- 6 Memory storage

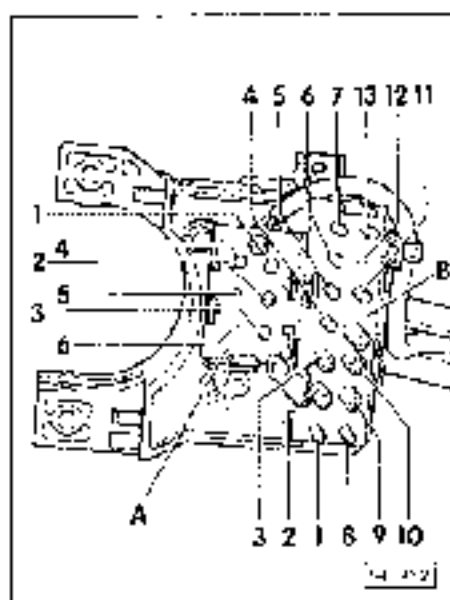

◀ Fig. 4 Connection assignment for windscreen wiper switch, headlight washer system and on-board computer

Notes:

- ◆ Assignment of 6-pin connector -A- -> Fig. 5
- ◆ Assignment of 13-pin connector -B- -> Fig. 6.

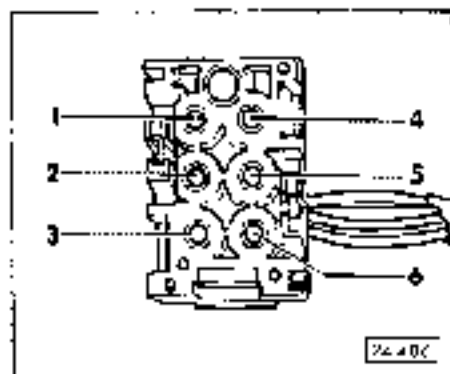

◀ Fig. 5 6 pin connector A

- 1 - On-board computer
- 2 On board computer reset
- 3 - On-board computer, right rocker
- 4 On board computer, left rocker
- 5 - Not used
- 6 - Not used

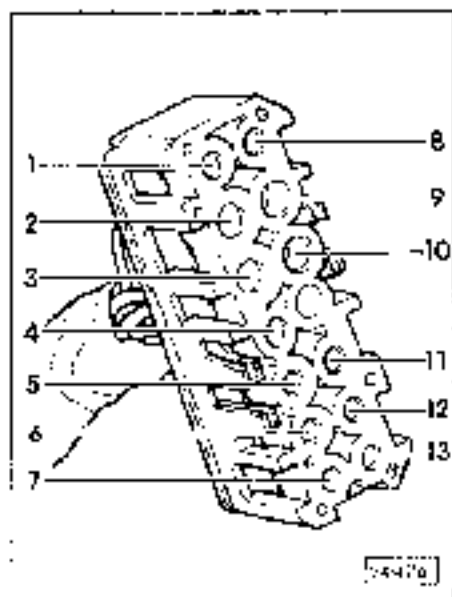

◀ Fig. 6 13-pin connector -B-

- 1 - Hazard warning switch, terminal L
- 2 - Windscreen wiper switch, terminal 53 a
- 3 - Windscreen wiper switch, terminal 53
- 4 - Windscreen wiper switch, terminal J
- 5 - Not used
- 6 - Windscreen wiper switch, terminal 53 c
- 7 - Hazard warning switch, terminal R
- 8 - Hazard warning switch, terminal 49 a
- 9 - Windscreen wiper switch, terminal 53 e
- 10 - Windscreen wiper switch, terminal 53 h
- 11 - Not used
- 12 - Not used
- 13 - Not used

#### Replacing individual contacts in connectors

##### Notes:

- ◆ Never use extractor tool
- ◆ Contact assignment => Page 94-47
- ◆ Always use appropriate current flow diagram for troubleshooting.

◀ => "Current Flow Diagrams, Electrical Fault Finding and Fitting Locations" binder

- Slide out plug catch by hand in direction of arrow as far as it will go

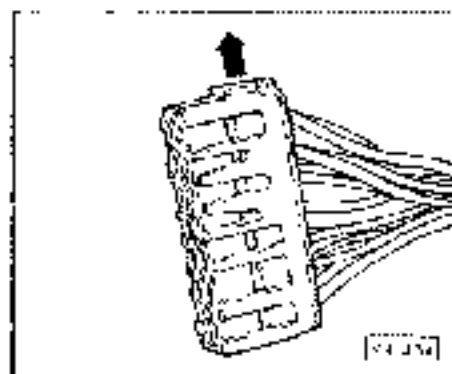

◀ Pull out and replace appropriate contact if necessary (damage, retrofitting or poor connection).

- To replace individual contacts, always use special tool 000 097 003 A or commercially available equivalent.

Insert contact in appropriate cavity.

- Push home plug catch.

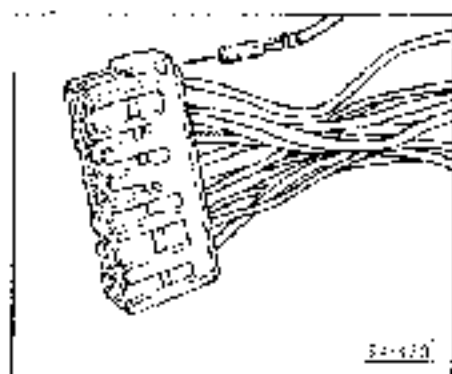

## Removing and installing ignition switch

- Removing steering column switch -> Page 94-28
- Removing cash insert -> Page 92-9
- Connections of ignition/starter switch -> Page 94-44.

### Removal

#### Note:

For the sake of clarity, the illustration shows the steering column lock housing removed.

Detach connector of ignition/starter switch.

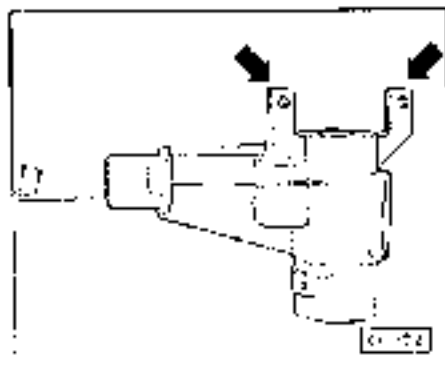

- ◀ - Remove sealing compound from fastening screws (arrows).
- Loosen screws

94-43

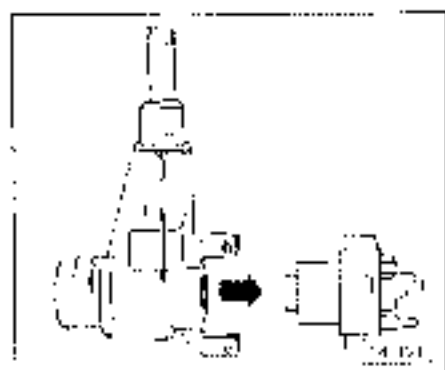

- ◀ - Pull out ignition/starter switch in direction of arrow.

#### Installation:

- Turn ignition key in ignition lock as far left as possible to "ignition off" position.
- Push in ignition/starter switch as far as it will go
- Tighten both fastening screws and seal with sealing compound.

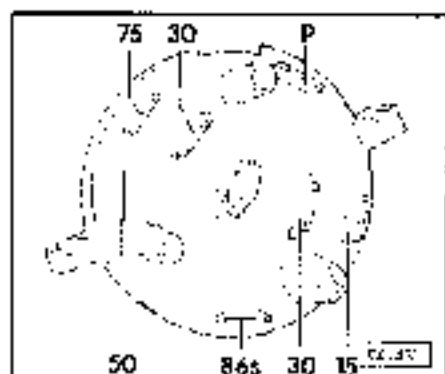

- ◀ Connections on ignition/starter switch

94-44

## Removing and installing steering column lock switch with lock cylinder

### Note:

If the lock cylinder has to be replaced in a vehicle fitted with an immobiliser, pay attention to reader coil replacement instructions => Page 96 4)

### Removal

- Removing steering column switch => Page 94-28
- Removing dash insert => Page 93 5
- Detach connector at ignition/starter switch.
- Pull off protective cap for steering column lock switch housing to front.

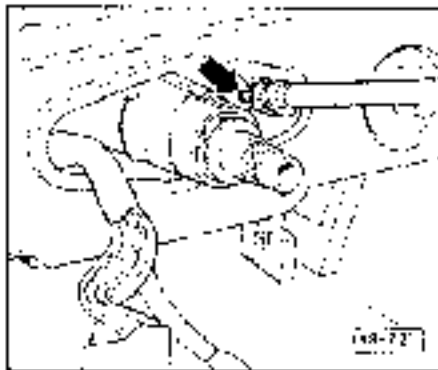

### Vehicles with automatic gearbox:

- Detaching cable for shift lock
- > Automatic Gearbox (1N): Repair Group 37: Servicing selector mechanism; Removing, installing and adjusting locking cable =>

### All vehicles:

- Remove securing bolt -arrow- using TORX insert with end-face hole T 30 II.

94-45

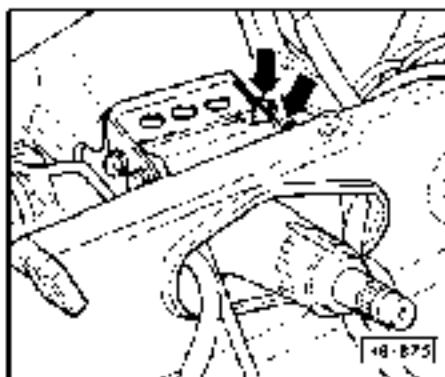

- Loosen both nuts -arrows- at steering column mount and remove the through-bolts.
- Disconnect transponder coil wiring.

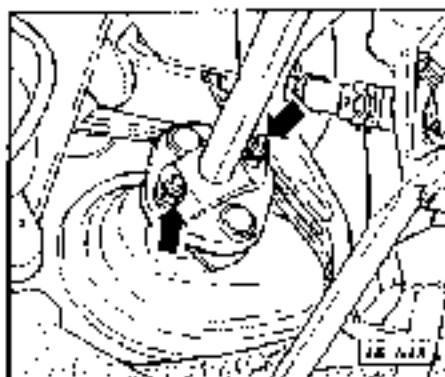

- Unscrew steering column from stop -arrows-.
- Use screwdriver to push steering column out of retainer stud bolts.
- Push down column tube until steering column lock housing can be removed.

94-46

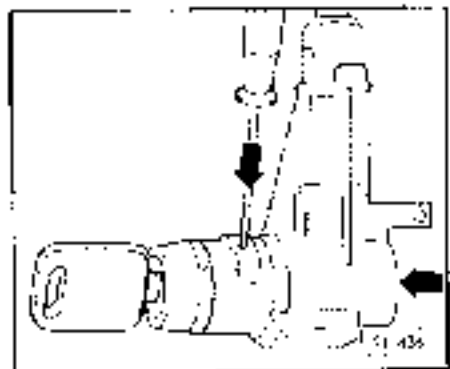
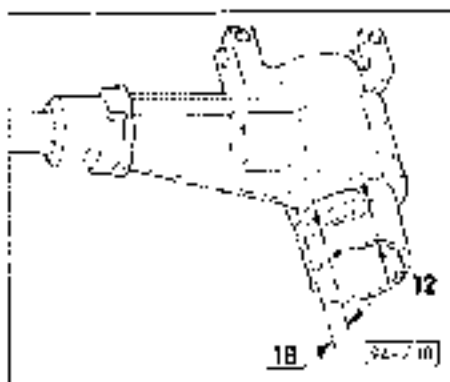

- ◀ - Use 3 mm diameter drill to spot drill steering column lock housing as per the dimensions shown.

**Warning**

Proceed with caution when doing so in order to avoid damaging the lock cylinder. Drilling depth approx. 1.5 mm.

- ◀ - Insert ignition key into steering column lock.
- Remove ignition/starter switch -> Page 94-43, so that it is possible to push on the pin end of the lock cylinder.
- Push out the lock cylinder -right arrow-; use makeshift mandrel to push rotating spring inwards -top arrow-.

94-47

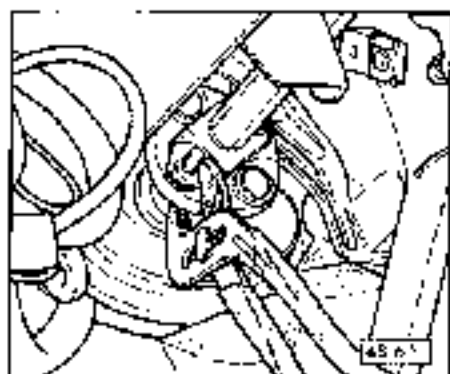
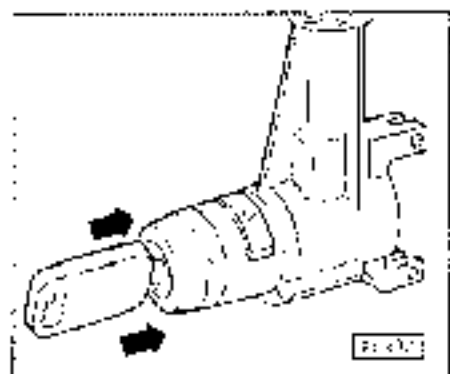

**Installing**

**Note:**

- ◀ *Renew all self locking nuts.*
- Set lock cylinder to "ignition off" position and insert in direction of arrow until retaining spring engages.
- Insert steering column lock housing at column tube; tighten TORX bolt to 7 Nm.
- Insert column tube into bracket.

- ◀ - Insert bolts in bracket and column tube; tighten new self locking nuts to 35 Nm.
- Release steering column lock so that steering column is free to turn.
- Press steering column into disc coupling using multiple slip-joint pliers.
- Insert retainer into steering column; tighten new self locking nuts to 25 Nm.
- Push protective cap for steering column lock onto column tube.
- Perform remaining installation operations in reverse order of removal.

94-48

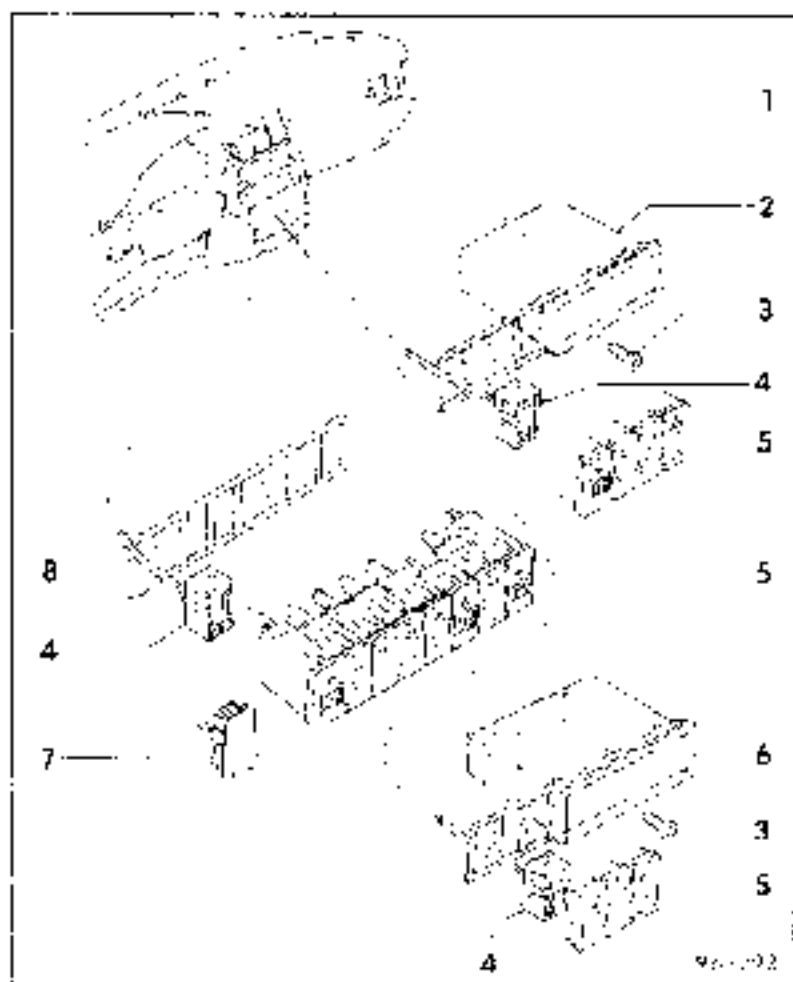

## Servicing switches in centre console

### Notes:

- ◆ Plug connections that are not required can be clipped to the back of the tray.
- ◆ When retrofitting individual systems, replace switch holder - item 6- with - item 0-.
- ◆ Recesses that are not required must be sealed off using dummy covers - Item 7-.

1 - Instrument panel

2 - Switch holder with small tray

- ◆ Remove all control switches to remove

96-1

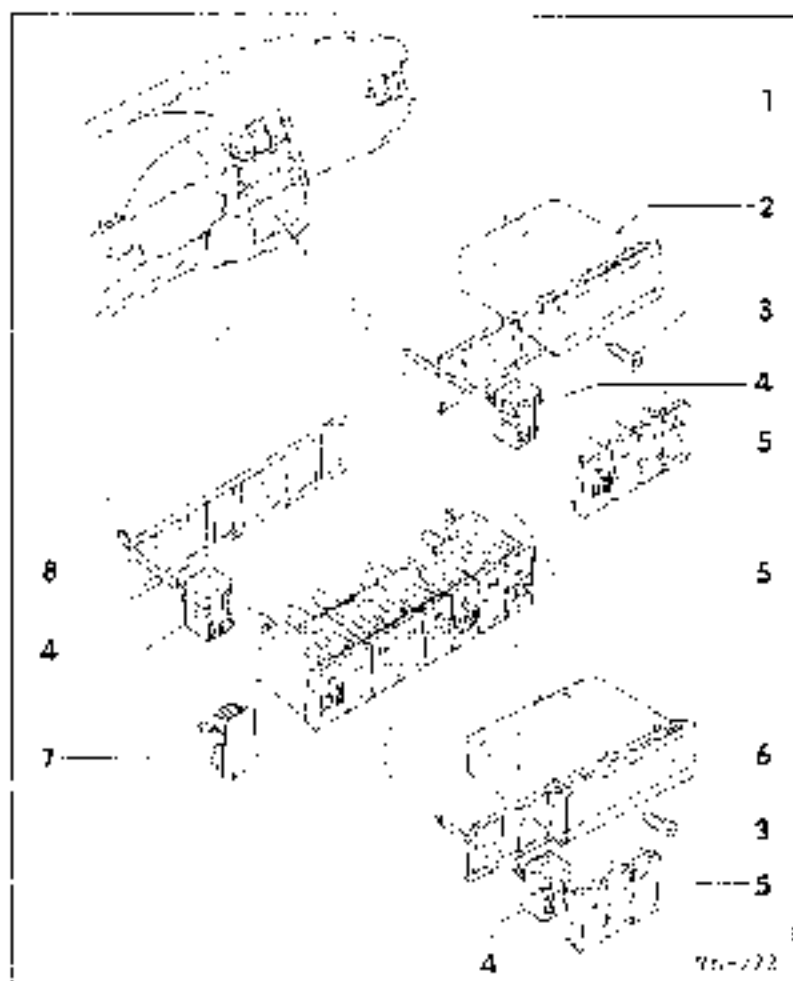

3 - Fastening screw

4 - Connector with wiring loom

- ◆ Pull or prise off from switch
- ◆ Contact assignment

=> "Current Flow Diagrams, Electrical Fault Finding and Fitting Locations" binder

5 - Pushbutton switch

- ◆ Removing and installing -> Page 96-4
- ◆ Replacing bulbs -> Page 96-6

6 - Switch holder with large tray

- ◆ Remove all pushbutton switches to remove

96-2

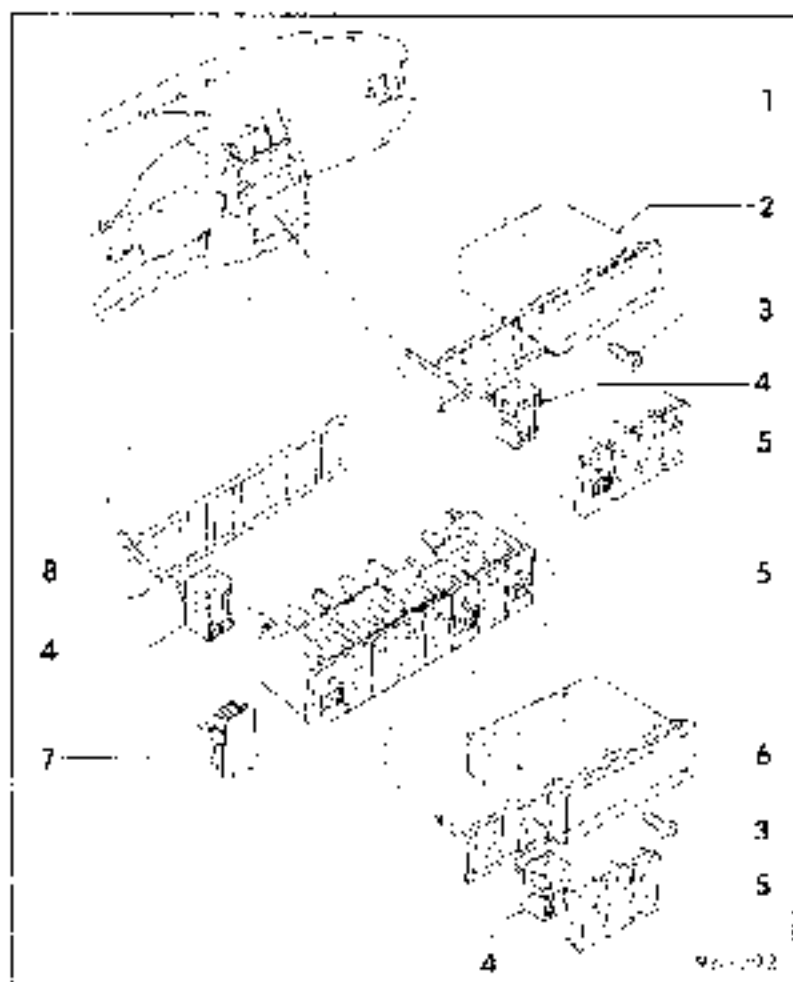

- 7 - Dummy cover**  
 ◆ Used to seal off switch strip if not fully assigned  
 ◆ Prise off
- B - Switch holder with no tray**  
 ◆ Remove all pushbutton switches to remove

### Removing and installing pushbutton switches

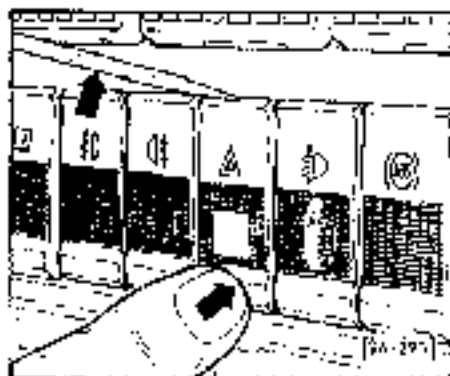

*Note:*  
*Radio does not have to be removed.*

**Removal:**

- ◆ - Mask area above switches and front of radio using masking tape.
- Use small screwdriver to carefully prise off switch button from above whilst pressing against opposite side

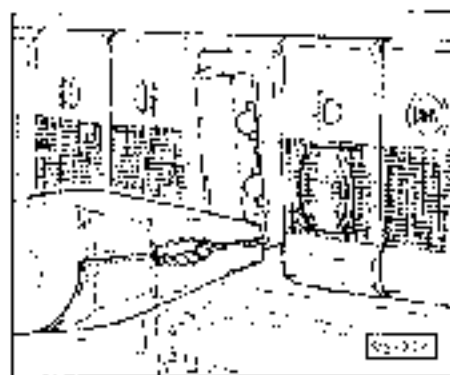

- ◆ - Pull switch forwards using universal or flat-nosed pliers
- Prise or pull off connector.

**Installation:**

- Press button onto removed switch until it can be heard to engage.

**Note:**

*Considerable force is required to press the button onto the heated rear window switch, for example.*

- Push on the connector and push switch back in again by hand.

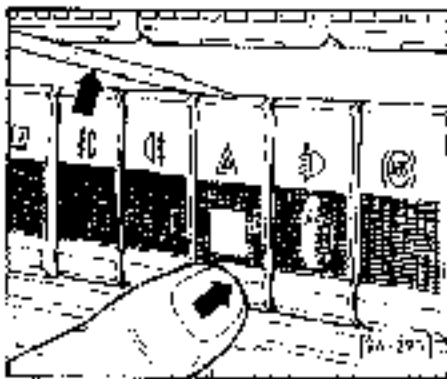
**Replacing bulbs in pushbutton switches**

- Mask area above switches and front of radio using masking tape.
- Use small screwdriver to carefully prise off switch button from above whilst pressing against opposite side.

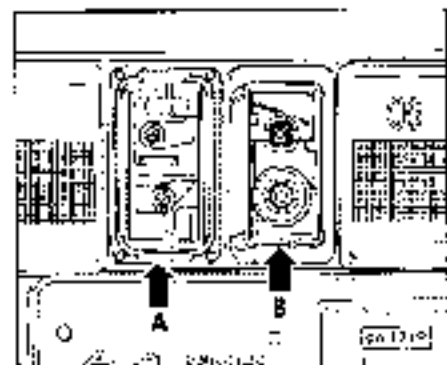

- A - Bulb replacement not possible
- B - Bulb replacement possible
- Extract bulb using pointed pliers or strong tweezers.
- Insert new bulb.
  - Use 2 W bulb for hazard warning switch.
  - Use 0.8 W bulbs for all other switches.



## Checking switch for electrically heated mirrors 07.92

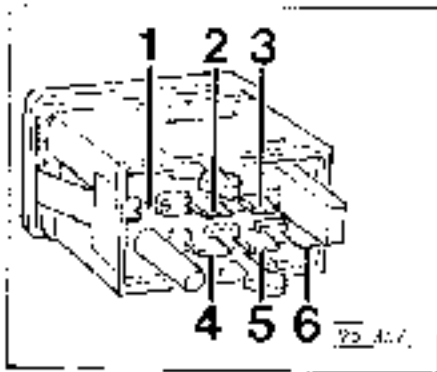

- Remove switch

### Checking switching contact for mirror heating

- Actuate switch.
- Measure from pin 5 to pin 3 using hand-held multimeter V.A.G 1526.

- Specified value: approx. 0.5 Ω

- Integrated fuse or switching contact is defective if specified value not attained

- Replace switch

### Checking switching contact for rear window heating

- Actuate switch.
- Measure from pin 5 to pin 6 using hand-held multimeter V.A.G 1526.

- Specified value: approx. 0.5 Ω

- Switch is defective if specified value not attained

- Replace switch

96-7

## Vehicles with air conditioner:

### Note:

*In vehicles with AC, the rear window heating and the mirror heating are actuated electronically. These electronics are activated by pushbutton and heat the rear window and the mirrors for 10 minutes via pin 6 and pin 3 respectively.*

- Actuate switch.
- Measure from pin 6 to pin 3 using hand-held multimeter V.A.G 1526.

- Specified value: approx. 0.5 Ω

Integrated fuse is defective if specified value not attained

- Replace switch

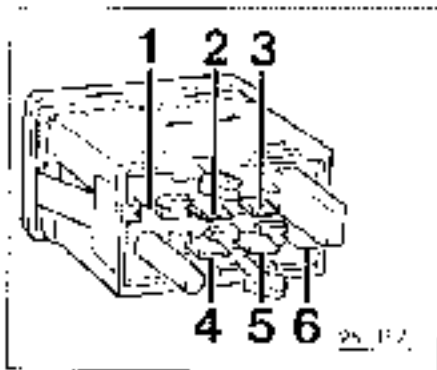

98-6

## Electric window lifters

### General notes:

- ◆ Consult appropriate current flow diagram and troubleshooting instructions during troubleshooting.
  - > "Current Flow Diagrams, Electrical Fault Finding and Fitting Locations" binder
- ◆ Before removing the electric window lifter, always determine exactly whether the fault/damage is in the wiring, mechanical components or motor/gear unit.
- ◆ Removing and installing window lifter from/re door component carrier
  - > General Body Repairs; Repair group 57; Front door; Removing window lifter and window from and installation on door component carrier ->
  - > General Body Repairs; Repair group 58; Rear door; Removing window lifter and window from and installation on door component carrier ->
- ◆ Adjust top end stop after installing window lifter (mechanism) or entire door component carrier

96-9

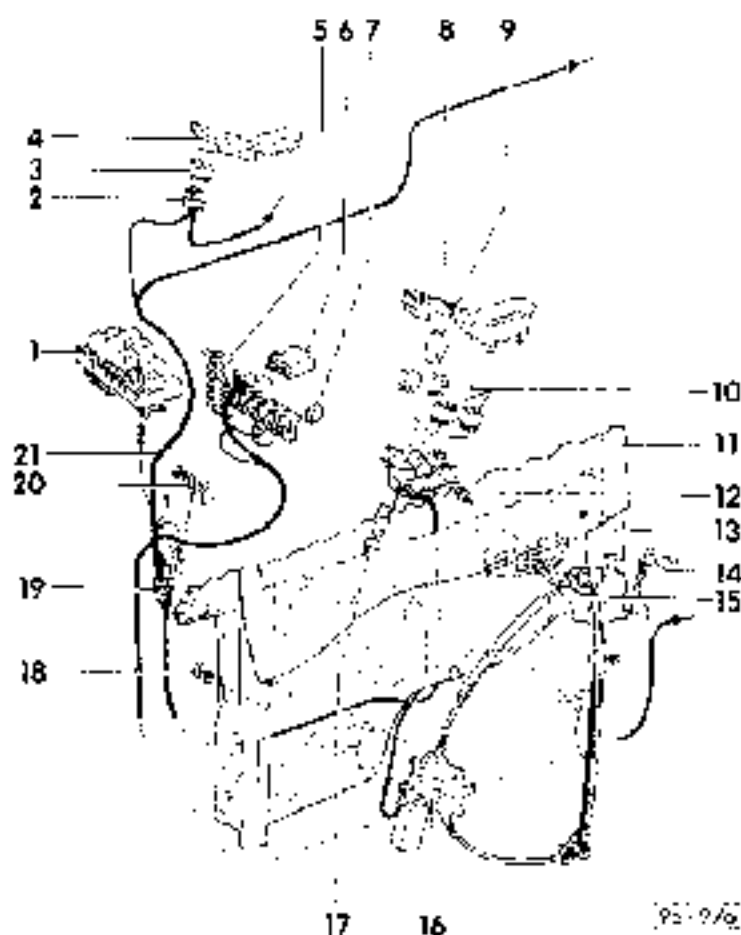

### Front electric window lifter – exploded view

#### 1 - Relay plate with fuse box

- ◆ Relay position assignment

-> "Current Flow Diagrams, Electrical Fault Finding and Fitting Locations" binder

#### 2 - Connector for front right switch unit

- ◆ Removing and installing -> Fig. 2

#### 3 - Window lifter switch -E107

- ◆ Removing and installing -> Fig. 3
- ◆ Checking -> Fig. 4

#### 4 - Console

- ◆ Lift up to remove

17

16

96-9/9

96 10

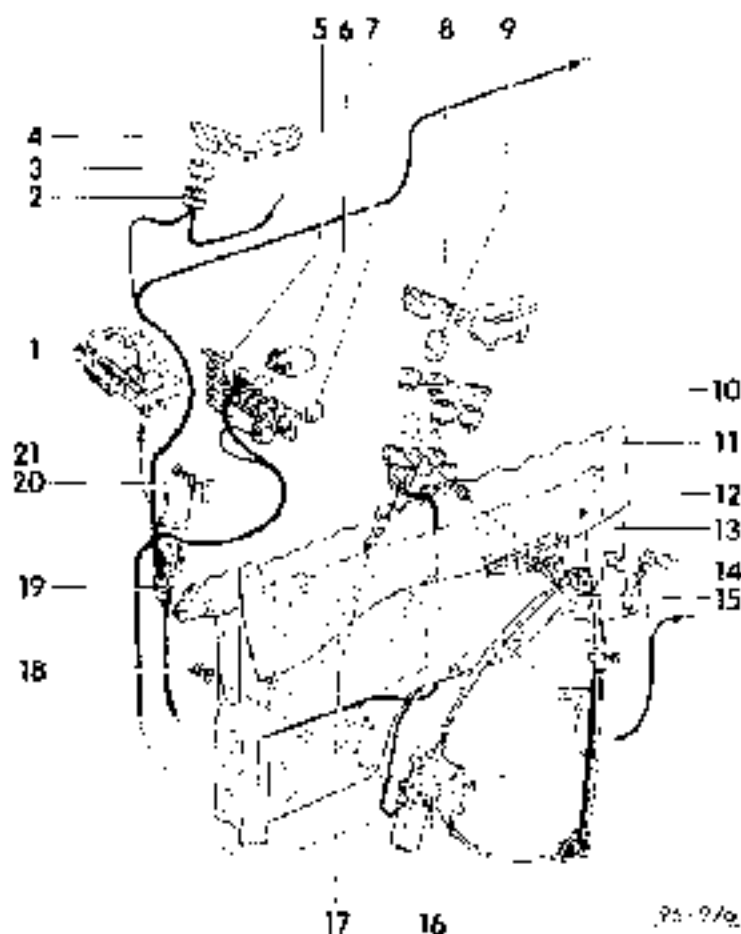

**5 - Auxiliary relay carrier**  
 ♦ Adapter clipped to long side  
 ♦ Relay position assignment  
 => "Current Flow Diagrams, Electrical Fault Finding and Fitting Locations" binder

**6 - Window lifter control unit -J139**  
 ♦ Press catch upwards to remove  
 ♦ Assignment  
 => "Current Flow Diagrams, Electrical Fault Finding and Fitting Locations" binder

**7 - Thermo fuse 20 A**  
 ♦ Location -> Fig. 1

**B - Console**  
 ♦ Lift up to remove

96-11

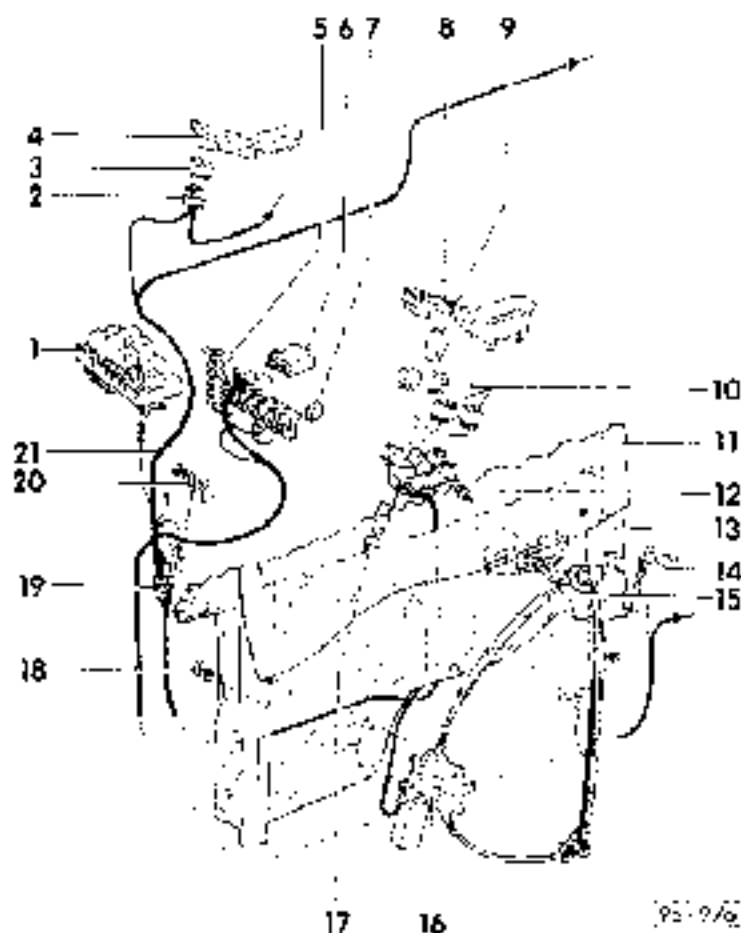

**9 - Rear window lifter isolation switch -E39**  
 ♦ Only fitted with rear electric window lifters  
 ♦ Removing and installing -> Fig. 5

**10 - Window lifter switches -E40, -E53, E55, E41**  
 ♦ Removing and installing -> Fig. 3  
 ♦ Checking -> Fig. 4

**11 - Front left door window**

**12 - Fastening screw**

**13 - Door component carrier**

**14 - Driver's door contact switch -F2**

96-12

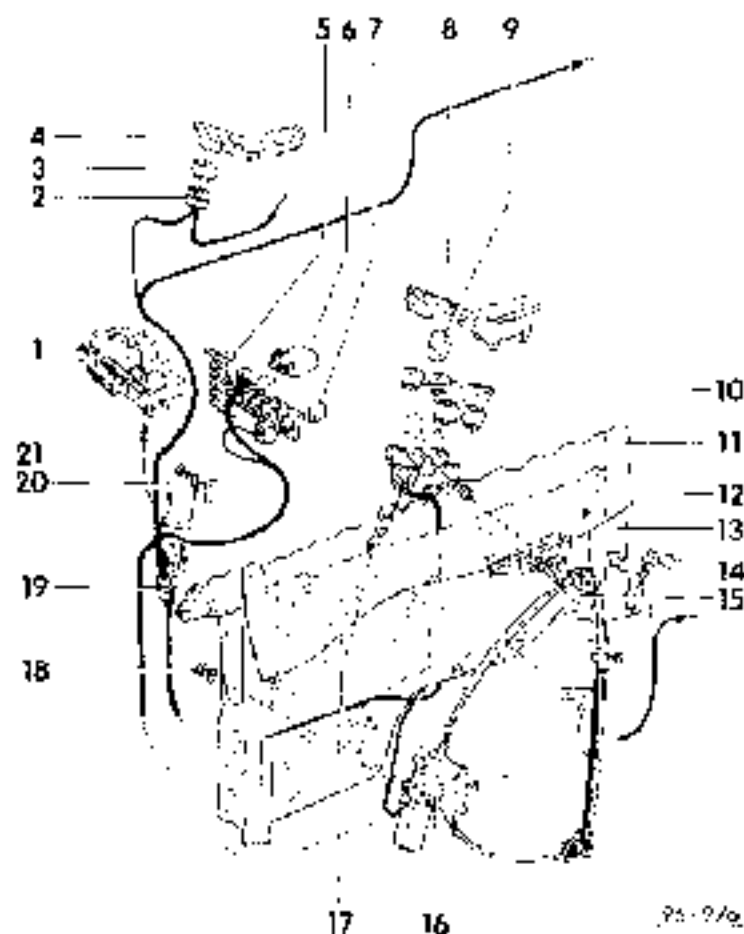

- 15 - Window fastening elements
- 16 Window lifter motor, left V14 with window filter mechanism
  - ◆ Ensure stress-free attachment by half-opening the window
- 17 - Connector for front left switch unit
  - ◆ Removing and installing -> Fig. 2
  - ◆ Not directly attached to switch, connected to 2-pin plug housing of window lifter wiring loom.
- 18 - Securing nut

96-13

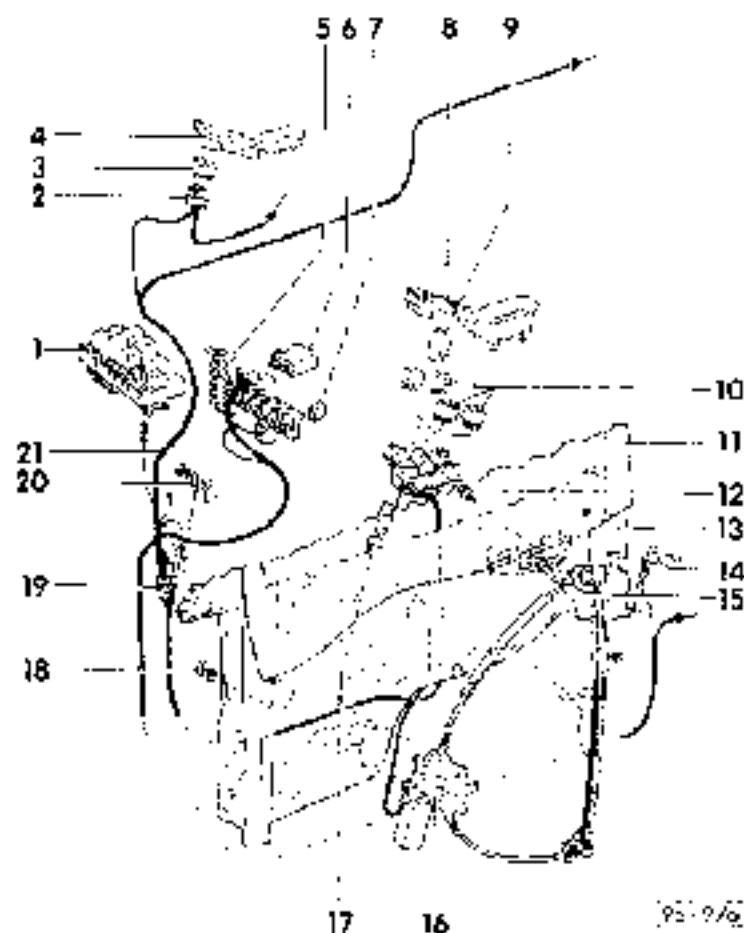

- 19 Connectors
  - ◆ Beneath instrument panel, on left
- 20 - Earth connection
  - ◆ Screwed to inside of A pillar
- 21 Wiring loom
  - ◆ Wiring and contact assignment
  - > "Current Flow Diagrams, Electrical Fault Finding and Fitting Locations" binder

96-14

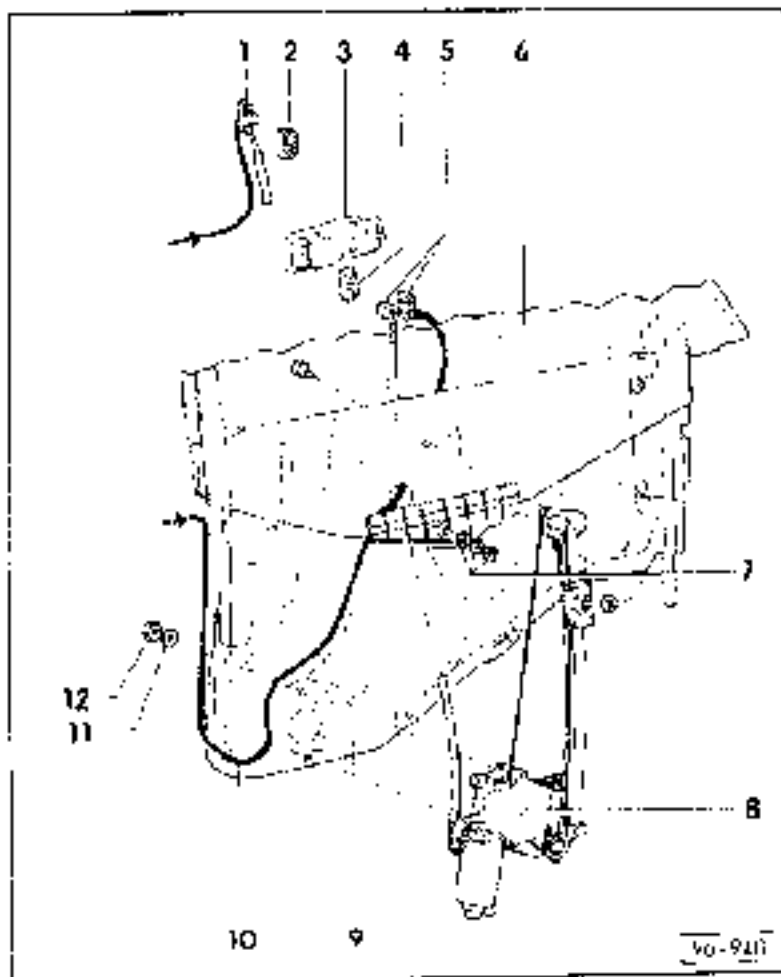

## Rear electric window lifters - exploded view

### Note:

The rear electric window lifter is an "open system" and must only be moved if bolted to the door component carrier. Otherwise the electric window lifter will be destroyed.

- 1 - Connector for right rear switch
  - ◆ Removing and installing -> Fig. 2
- 2 - Rear right window lifter switch - E54
  - ◆ Removing and installing -> Fig. 3
  - ◆ Checking -> Fig. 4

96-15

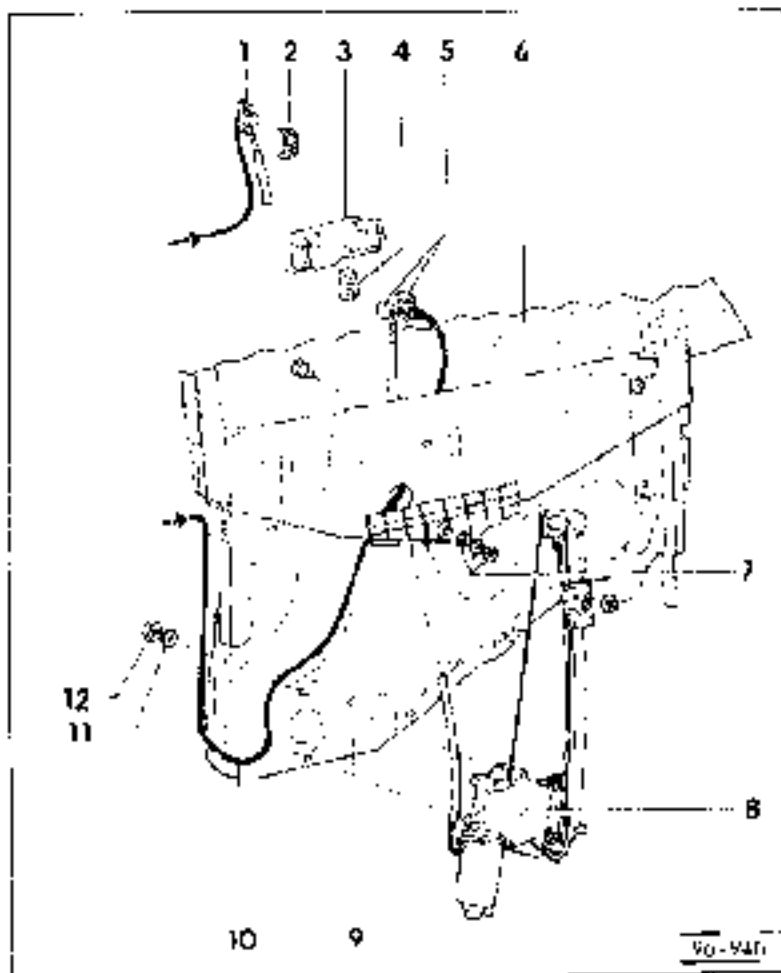

- 3 - Inside door mechanism
  - ◆ Remove to take out switch
- 4 - Rear left window lifter switch - E52
  - ◆ Removing and installing -> Fig. 3
  - ◆ Checking -> Fig. 4
- 5 - Connector for left rear switch
  - ◆ Removing and installing -> Fig. 2
- 6 - Rear left window
- 7 - Window fastening elements

96-16

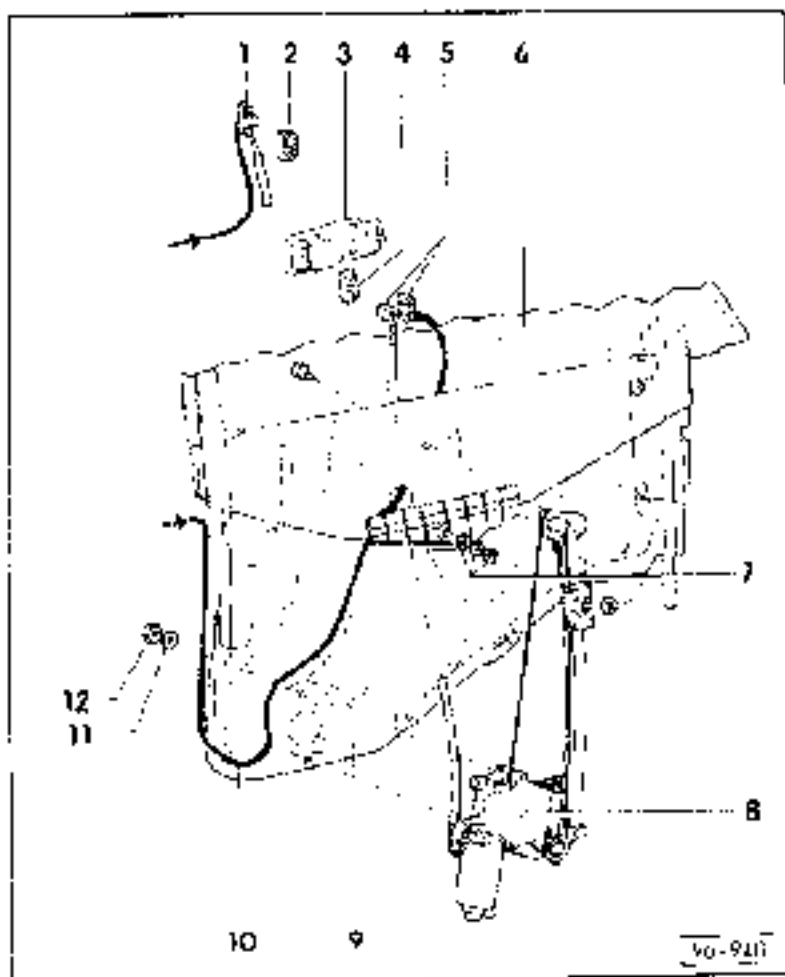

6 - Rear left window lifter motor - V26 with window lifter mechanism  
 ♦ Ensure stress-free attachment by half-opening the window

9 - Door component carrier

10 - Window lifter wiring loom  
 ♦ Wiring and contact assignment

-> "Current Flow Diagrams, Electrical Fault Finding and Fitting Locations" binder

11 - Washer

12 - Securing nut

96-17

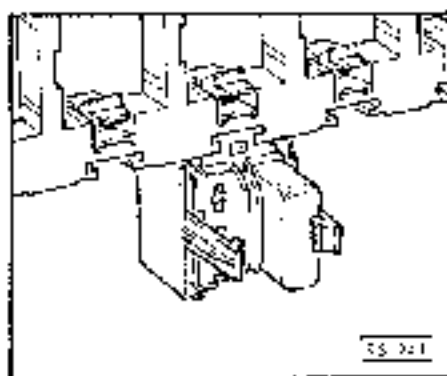

◀ Fig. 1 Thermo fuse location

♦ In auxiliary relay carrier on left beneath instrument panel

♦ Relay position

-> "Current Flow Diagrams, Electrical Fault Finding and Fitting Locations" binder

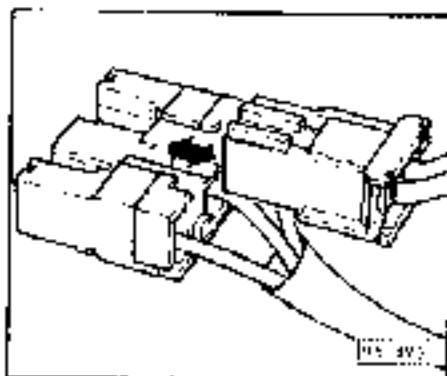

◀ Fig. 2 Removing and installing connector for switch unit

- To remove, unclip 2-pin connector for electric window lifter from plug housing to rear by turning it sideways.

- To install, push 2-pin connector into 3-pin plug housing from rear until both engage

96 18

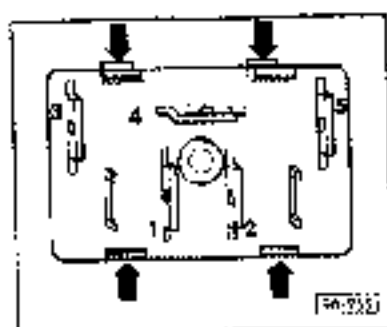

◀ Fig.3 Removing and installing switch

**Front door:**

- 4- and 5-cyl. > 06.93: Place small screwdriver between door trim and console and prise out console together with switch unit.
- 4 and 5 cyl. 7.93 >, 6 cyl., S2: Removing door handle
- > General Body Repairs; Repair group 70; Door trim; Removing and installing front door trim (4 and 5 cyl. 7.93 >, 6 cyl., S2) - >
- Remove switch unit from door handle.

**Rear door:**

- Removing interior door handle
- > General body repairs; Repair group 70; Door trim; Removing and installing rear door trim - >

**All vehicles:**

- Remove plug
- Use small screwdriver to prise long sides of switch arrows out of catch and push out switch.
- To install, push in switch until all retaining lugs engage.

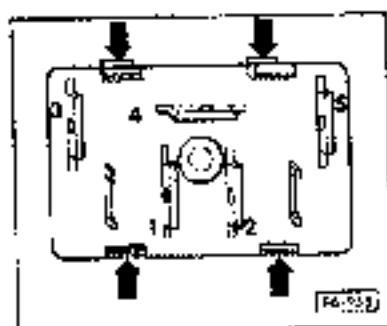

◀ Fig.4 Functional test of switch

- Remove switch
- Connect ohmmeter.

Contact	Test condition	Specified value
5 - 2	.	0 Ω
3 - 1	.	0 Ω
4 - 2	.	∞ Ω
4 - 2	Actuate switch "open"	0 Ω
4 - 1	.	∞ Ω
4 - 2	Actuate switch "close"	0 Ω

◀ Fig.5 Removing and installing locking switch for rear window lifter

Position small screwdriver in recesses (arrows), press towards centre of switch and carefully push out the switch.

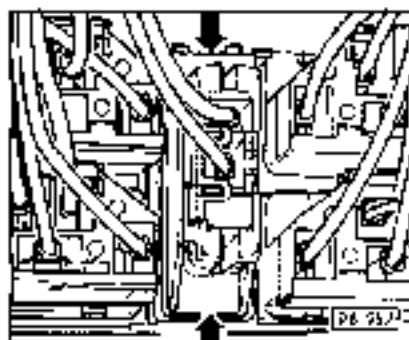

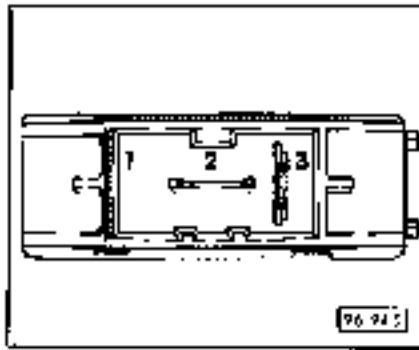

◀ Fig.6 Functional test of locking switch for rear window lifter

Remove switch

– Connect ohmmeter:

Contact	Test condition	Specified value
2 - 3	Button not pressed	> 5Ω
2 - 3	Button pressed	0 Ω

Replace switch if the specified values not attained

## Dismantling and assembling electric window lifters

### Notes:

- ◆ The rear electric window lifter is an 'open system' and must only be moved if bolted to the door component carrier. Otherwise the electric window lifter will be destroyed. The entire window lifter therefore has to be replaced if repairs are required.
- ◆ Replacement of the motor/gear unit assembly is described in the following
- ◆ The mechanical section (linkage/cable) is replaced in the same way. The upper door stop must then be adjusted.
  - > General body repairs; Repair group 57; Front door; Door component carrier – exploded view – >
  - = > General body repairs; Repair group 58; Rear door; Door component carrier – exploded view = >
- Removing window lifter from door component carrier
  - > General Body Repairs; Repair group 57; Front door; Removing window lifter and window from and installation on door component carrier – >
  - = > General Body Repairs; Repair group 58; Rear door; Removing window lifter and window from and installation on door component carrier – >



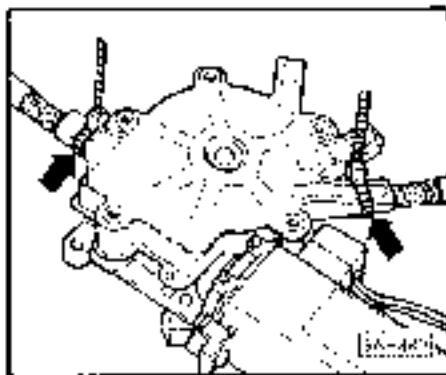

- ◀ - To secure in position, use cable ties to lightly connect metal housing cover and plastic cover at both cable exits - arrows

**Note:**

*Both cable ties may be left in place throughout the entire sequence of repair operations, since servicing would otherwise be impossible*

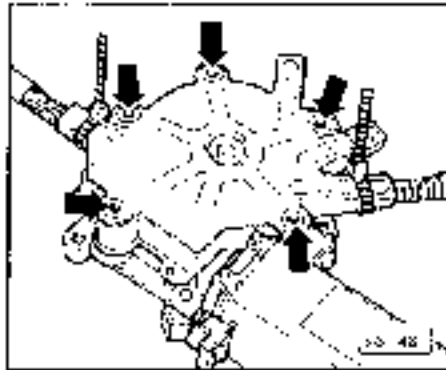

- ◀ Completely unscrew and remove gear unit cover securing bolts - arrows .

———— 96-23 ————

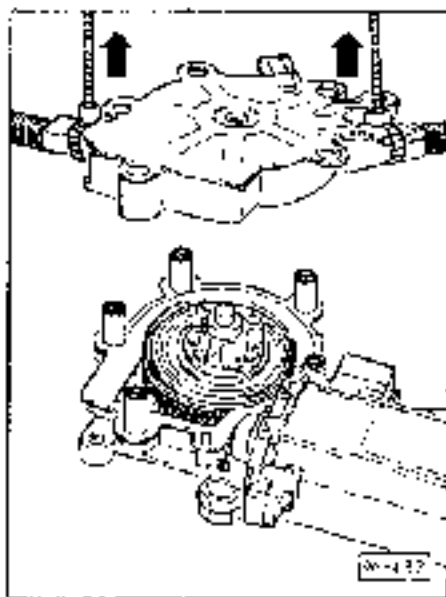

- ◀ - Pull cable reel from gear housing by hand in direction of arrow by tilting gently from side to side. Take care not to damage sealing surfaces.
  - The 3 camper elements in the recesses may drop out - take care not to lose them.

———— 96-24 ————

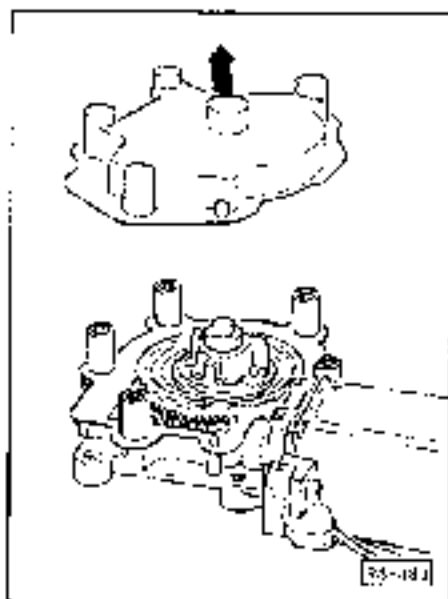

- ◀ - Pull dust and transportation cover from new motor in direction of arrow.

Ensure that flange seal and 3 winged retainer remain on gear housing

**Note:**

*Surfaces/components that are coated with grease must not be allowed to come into contact with dust or dirt. Only original grease G 000 450 02 should be used for regreasing*

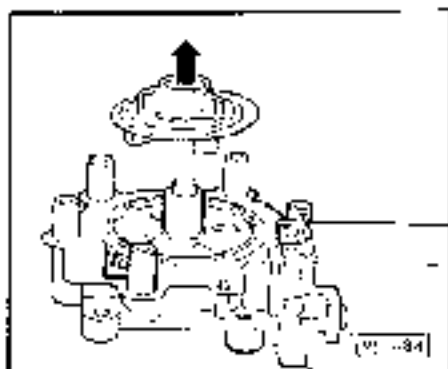

- ◀ - Pull 3-winged retainer off gear shaft of new motor in direction of arrow. Leave rubber moulding in gear housing.
- Check transmission components (rubber moulding, damping element) for damage, replace if necessary.

96-25

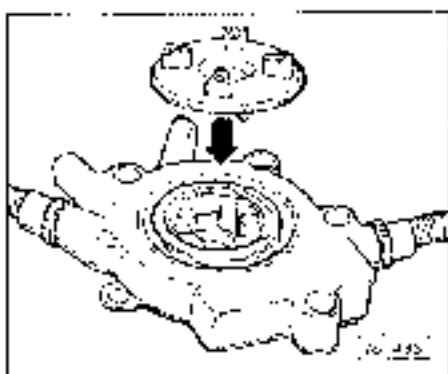

- ◀ - Insert 3-winged retainer in cable reel.

**Note:**

*The 3 damping element must fit exactly into the cable reel recesses*

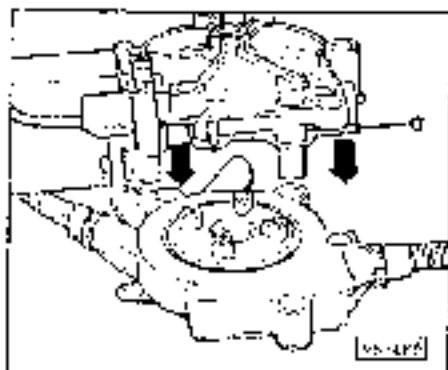

- ◀ Attach window filter motor to cable reel in direction of arrow
  - The 4 lugs of the 3-winged retainer must coincide with the recesses in the rubber moulding in the gear housing.

**Note:**

*If applicable, coat flange seal and gear wheel in gear housing with a thin film of grease to stop them falling out.*

96-26

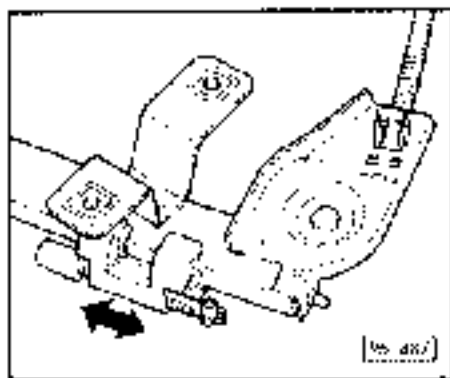

- ◀ - If gear housing cannot be properly attached to cable reel, shift driver arrow slightly to alter position of rubber moulding so that it engages

*Note:*

*Never turn adjusting screw for top stop*

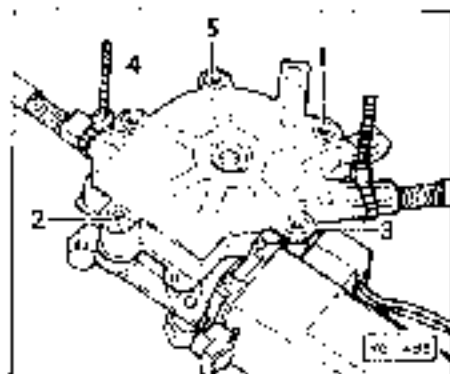

- ◀ Screw in securing bolts and tighten to 3 Nm in the order shown

96-27

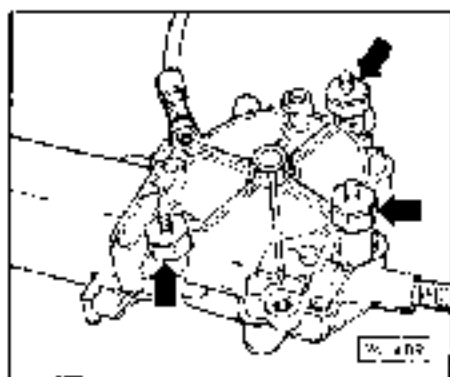

- ◀ - Unscrew bonded rubber bushes -arrows- from defective window lifter motor.
- Replace defective bonded rubber bushes.
- Fit bonded rubber bushes in new window lifter motor and tighten to 3 Nm.
- Test operation before installing in door component carrier
- To avoid scratching noise during operation, cut off protruding ends of subsequently attached cable ties.

96-28

## Electrically adjustable seats

### Notes:

#### ◆ Troubleshooting instructions

-> "Current Flow Diagrams, Electrical Fault Finding and Fitting Locations" binder

#### ◆ Assignment of pins in connectors

-> "Current Flow Diagrams, Electrical Fault Finding and Fitting Locations" binder

#### Removing seat

-> General Body Repairs; Repair Group 72, Front Seat, Removing and installing front seat ->

#### Removing backrest

=> General Body Repairs; Repair Group 72, Front Seat, Removing and installing backrest ->

Function test => Page 58 42

96-29

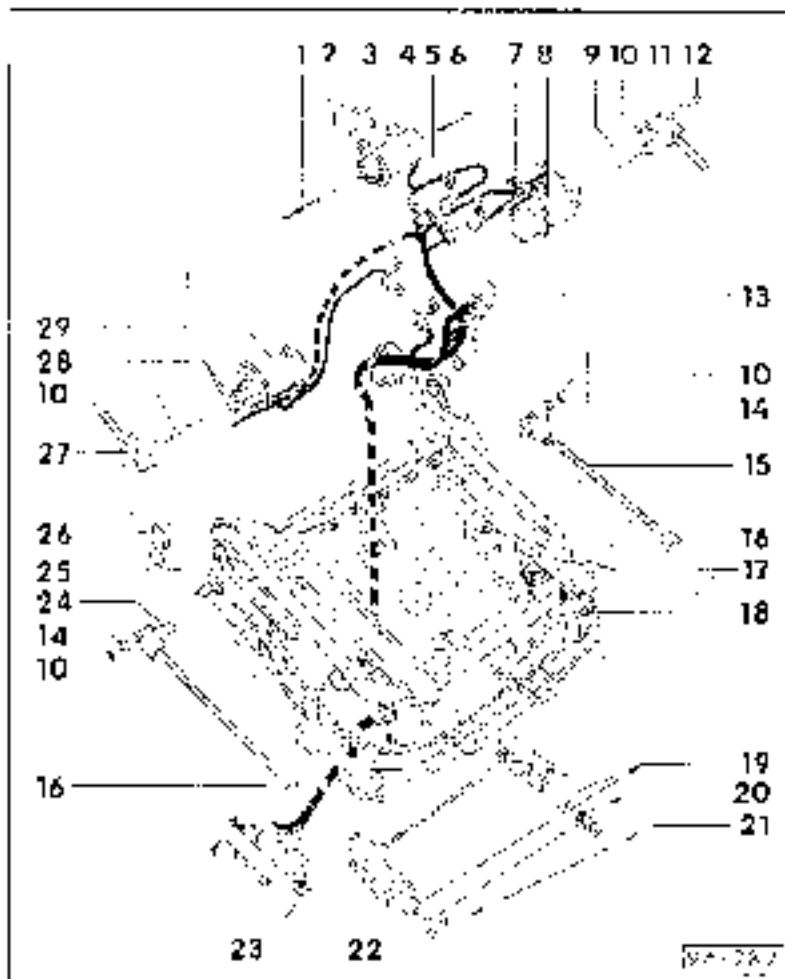

### Electrically adjustable seat – exploded view

- 1 - Left drive shaft
  - ◆ For fore-and-aft adjustment
- 2 - Securing nut
- 3 - Grommet
- 4 - engine
  - ◆ For fore-and-aft adjustment
  - ◆ Removing and installing
    - > Page 56 30
- 5 - Retaining clip
  - ◆ For connector
- 6 - Right drive shaft
  - ◆ For fore-and-aft adjustment

96 30

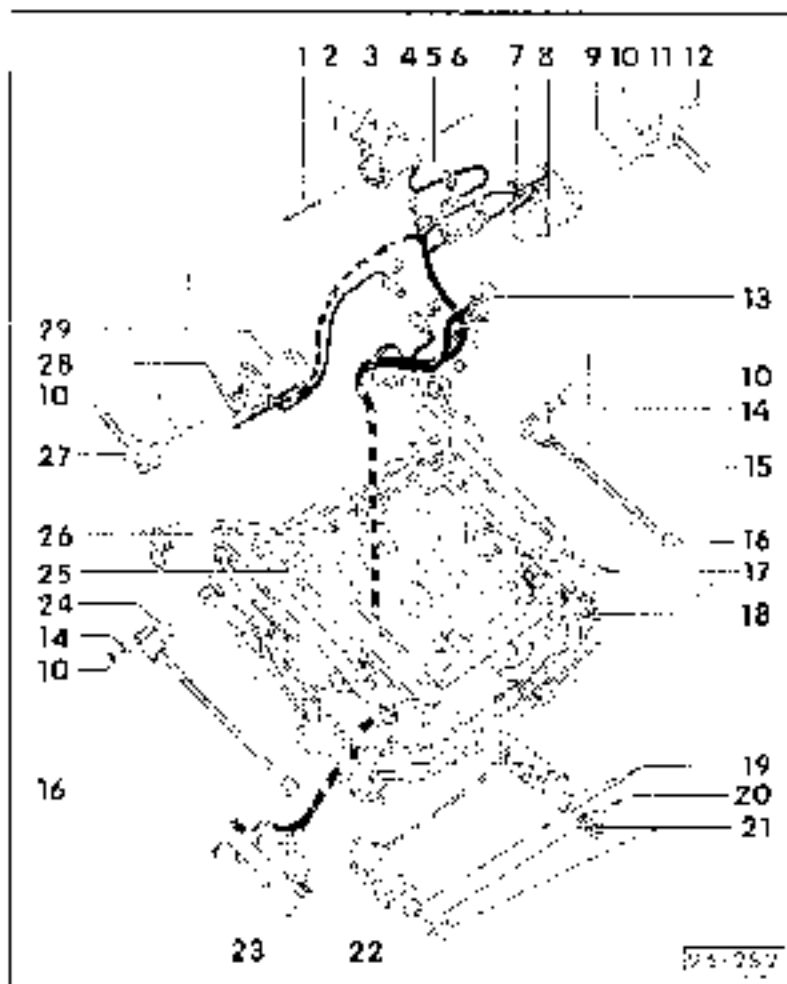

7 - Cable tie

8 - engine  
 ♦ For front height adjustment  
 ♦ Removing and installing - >  
 Page 96-38

9 - Drive shaft  
 ♦ For adjuster

10 - Circlip

11 - Adjuster  
 ♦ For front height adjustment  
 ♦ Removing and installing - >  
 Page 96-43

12 - Fastening pin  
 ♦ For adjuster - item 11

13 - Connector  
 ♦ For wiring harness

96-31

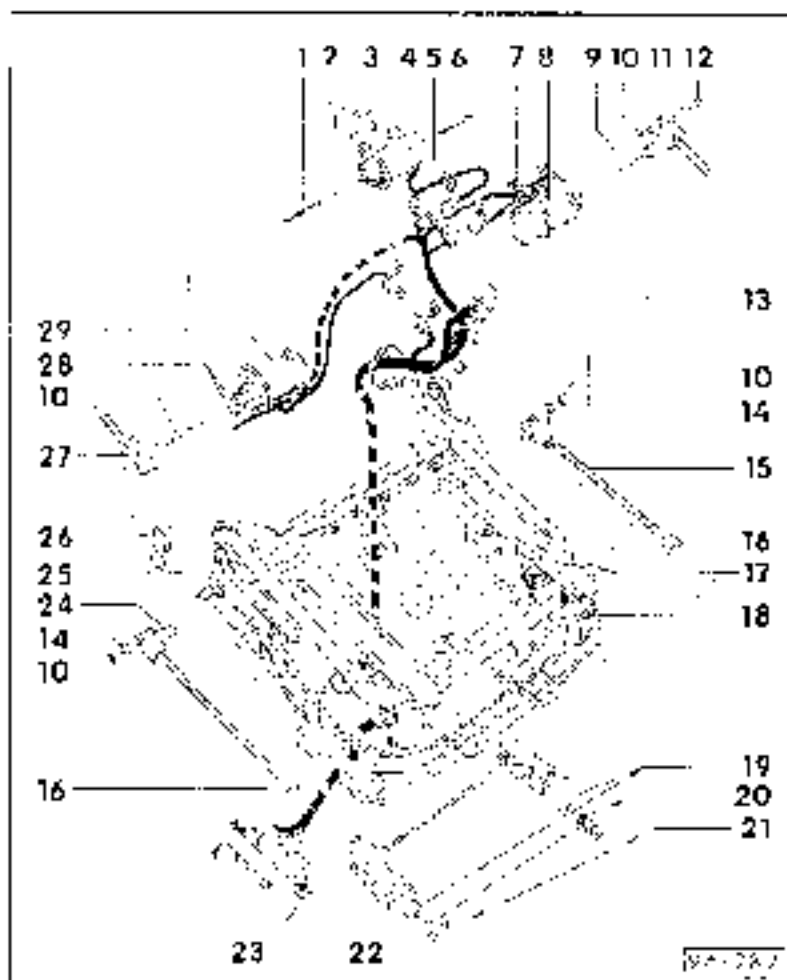

14 - Shim

15 - Right adjuster  
 ♦ For fore-and-aft adjustment  
 ♦ Removing and installing - >  
 Page 96-43

16 - Rear rubber stop  
 ♦ For rear height adjustment

17 - Securing bolts  
 ♦ For motor - item 8

18 - Rivet  
 ♦ For fastening spindle holder

19 - Front rubber stop

20 - Bush

96-32

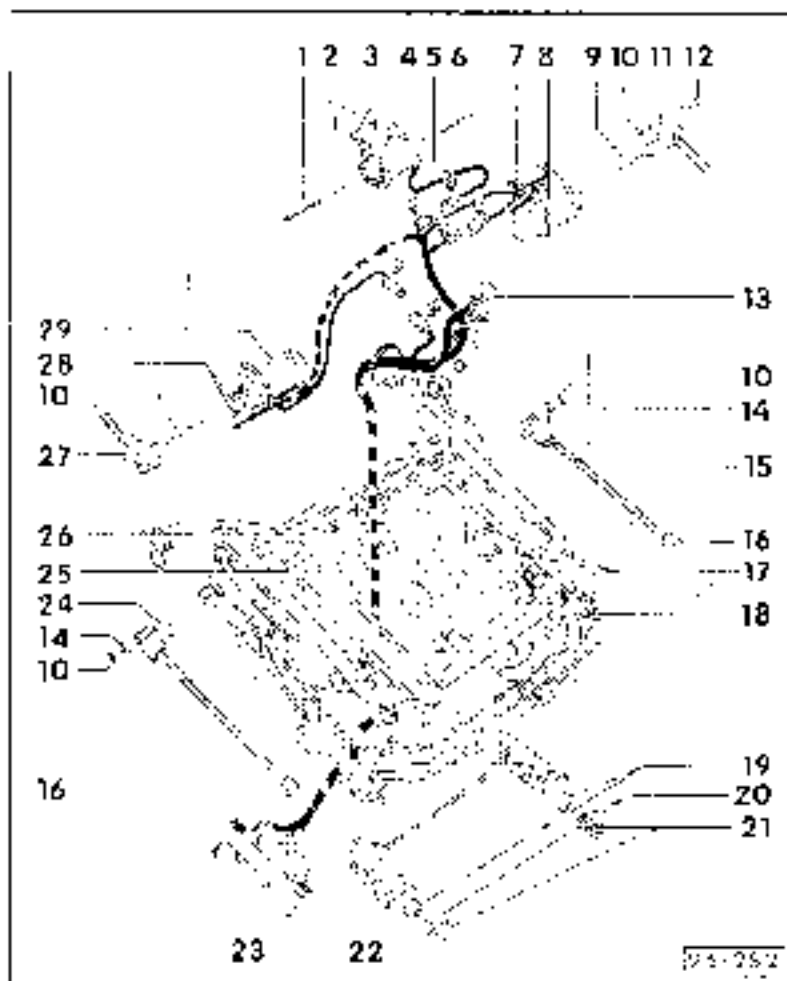

- 21 - Spindle holder
  - ◆ Removal. Grind off rivet and drive out
  - ◆ Installation. Secure using blind rivet or M5 screw
  
- 22 - Runners
  - ◆ Removing and installing adjuster with runners - > Page 96-40
  
- 23 - Switch unit with wiring loom
  - ◆ Supplied as one unit, no individual replacement
  - ◆ Removing and installing - > Page 96-27

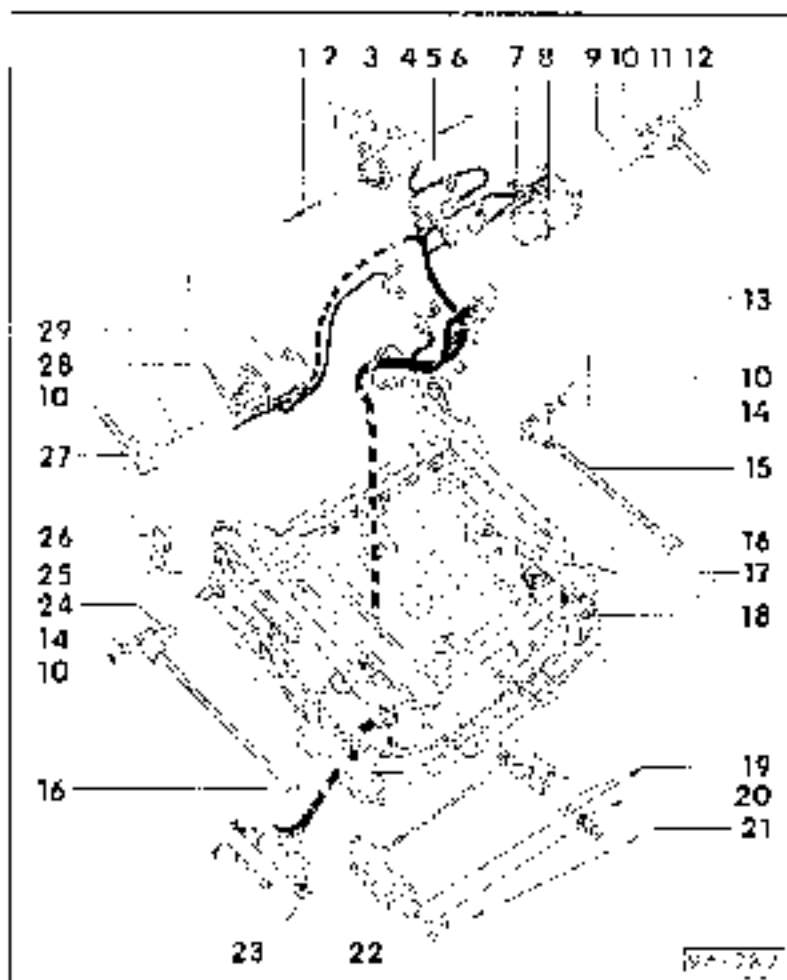

- 24 - Left adjuster
  - ◆ For fore-and-aft adjustment
  - ◆ Removing and installing - > Page 96-43
  
- 25 - Seat base frame
  - ◆ With runner guides
  
- 26 - Fastening pin
  - ◆ For adjuster
  
- 27 - Adjuster
  - ◆ For rear height adjustment
  - ◆ Removing and installing - > Page 96-40
  
- 28 - Securing bolts
  - ◆ For motor item 29-
  
- 29 - engine
  - ◆ For rear height adjustment
  - ◆ Removing and installing - > Page 96-30

**Electrically adjustable backrest  
- exploded view**

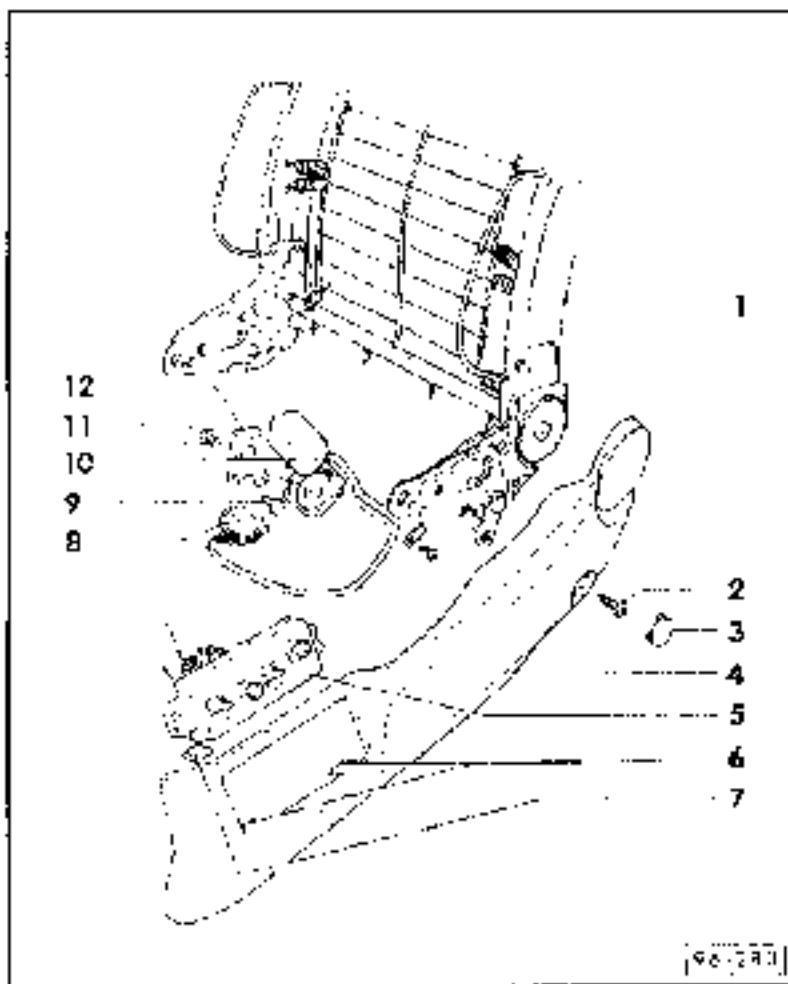

- 1 - Seat back
- 2 - Fastening screw
  - ◆ For side trim
  - ◆ Screwed into stop pin for backrest
- 3 - Trim cap
  - ◆ Prise out
- 4 - Side trim
- 5 - Seat switch unit
  - ◆ Removing and installing -> Page 96-37

96-35

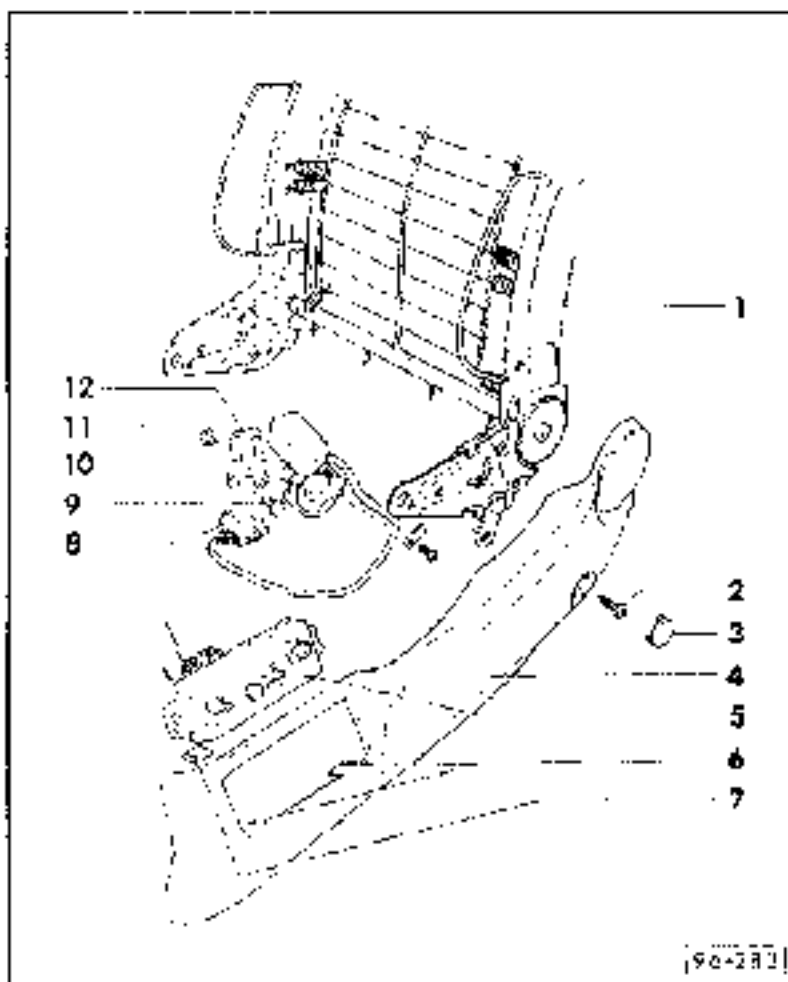

- 6 - Catch for switch unit
  - ◆ Integrated into side trim
  - ◆ To remove, prise off clips carefully with screwdriver
- 7 - Retaining clip
  - ◆ Prise out before removing side trim
- 8 - Connector
- 9 - Fastening screw
- 10 - Backrest adjustment motor
  - ◆ Removing and installing -> Page 96-41
- 11 - Fastening screw
- 12 - Retainer
  - ◆ For backrest adjustment

96-36

### Removing and installing switch unit on seat

- Use small screwdriver to lever off fastening screw cap
- Screw fastening screw out of backrest stop bolt.
- Prise off retainers
- Disengage side trim for seat from switch trim at seat frame and remove
- Loosen the two fastening screws and remove switch unit.

**Note:**

*Switch unit and wiring loom form a single unit and can only be replaced as a complete assembly.*

96-37

### Removing and installing front/rear seat height adjustment motor

- Seat removed

**Note:**

*If removal or installation work involves removing individual adjusters or detaching them from the drive shafts, ensure that the individual adjusters do not become bent.*

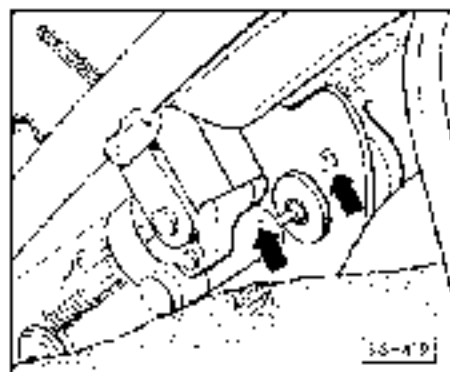

- ◀ Remove motor securing bolts (arrows)
- Pull drive shaft out of motor
- Detach connector

96-38



## Removing and installing longitudinal adjustment motor

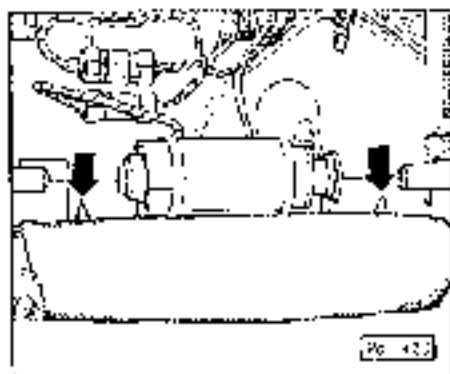

- Seat removed
- ◀ - Bend open clips for securing fabric -arrow- and detach fabric from rear cross member as required

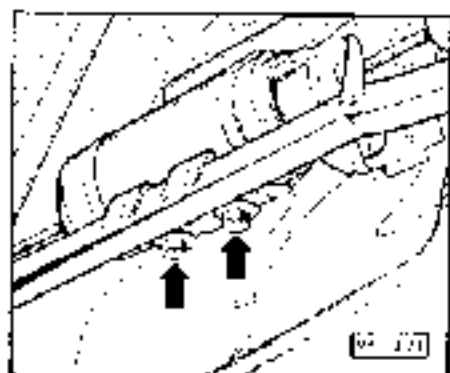

- ◀ - Remove both nuts arrows from motor at seat cross member.
- Pull drive shafts out of both end faces of motor.
- Detach connector.

96-39

## Removing and installing front/rear height adjuster

- Seat removed
- Prise retaining ring from securing pin and pull out the pin.
- Pull drive shaft out of adjuster
- Screw adjuster with spindle out of holder by hand.

## Removing and installing longitudinal adjuster

- Seat removed
- Grind off or drill out rivets for spindle holders on right and left at runner guide.
- Remove spindle holders and rubber buffers

96-40

## Removing and installing backrest adjustment motor

- Seat removed
- Backrest removed
  - Detach fabric at bottom of backrest and carefully pull forward to the necessary extent.
  - Remove hexagon bolts for motor bracket from backrest hinge
  - Unscrew bracket from motor
  - Pull off/solder motor connecting lead.

## Functional test of electrically adjustable seats

- After repair work
  - Installing seat
    - > General Body Repairs; Repair Group 1/2: Front Seat: Removing and installing front seat - >
    - Use seat switches to move seat to all possible positions
    - > Owner's manual
  - It must be possible to move the seat to all possible positions in accordance with switch setting

## Servicing cruise control system

### Notes:

◆ Checking vacuum system -> Page 96-43

◆ Troubleshooting

-> "Current Flow Diagrams, Electrical Fault Finding and Fitting Locations" binder

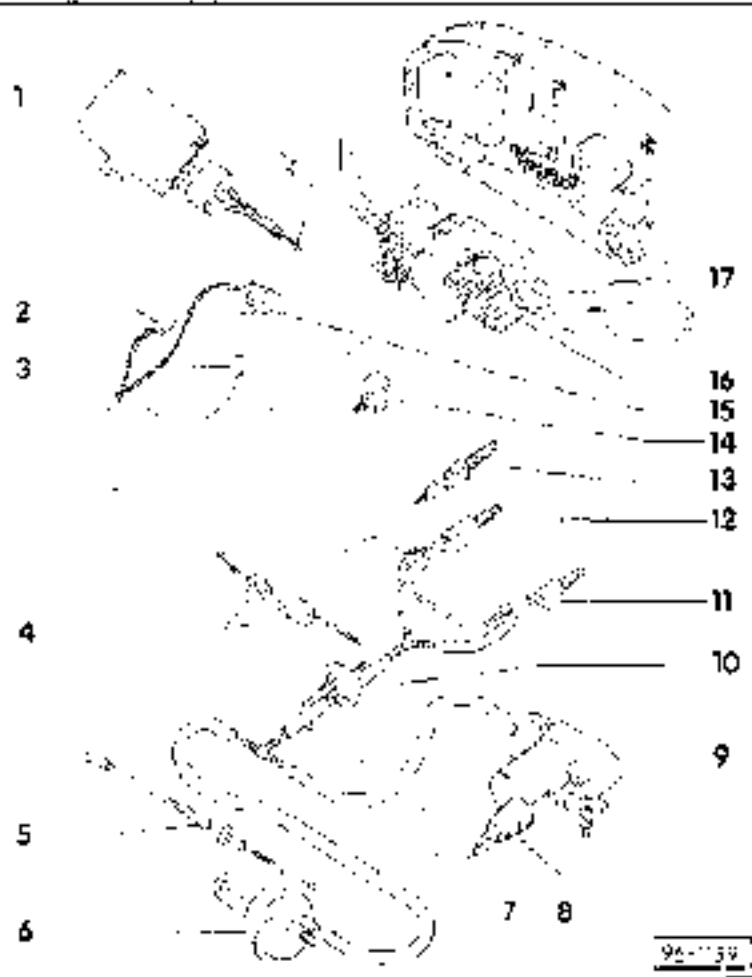

1 - Control unit

◆ Removing and installing -> Fig. 1

2 - Test connection with cable link

◆ Production only

◆ Automatic gearbox only

3 - Earth connection

◆ Beneath instrument panel

96-43

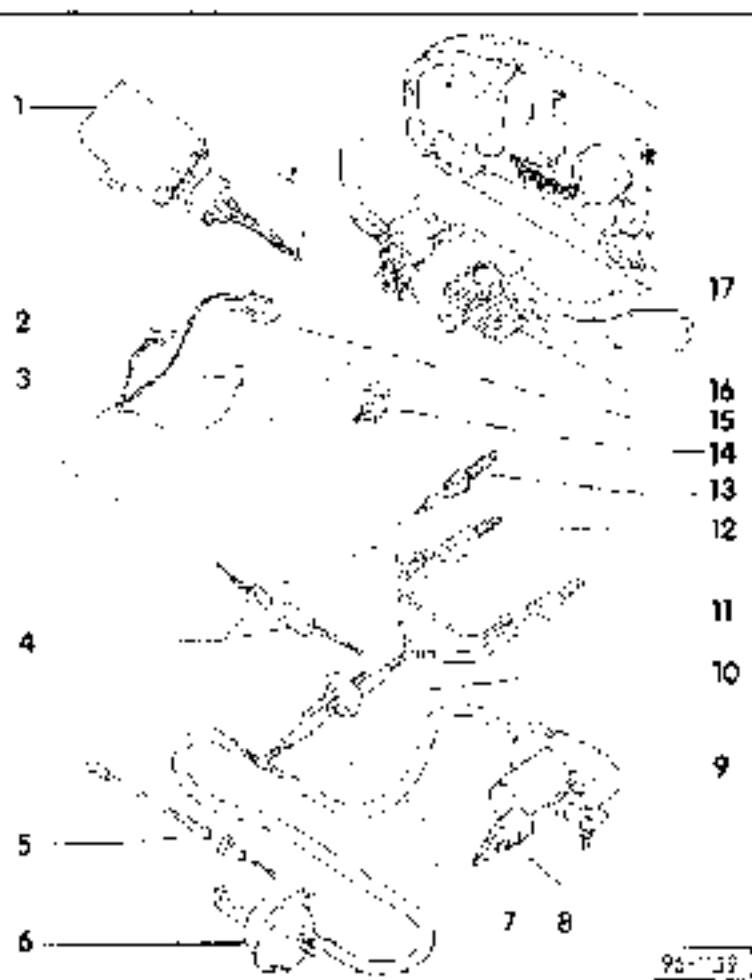

4 - 6 way connector

◆ Blue

5 - Linkage

◆ Adjusting, vehicles with petrol engine

4-cyl. engine -> Fig. 2.

6-cyl. engine -> Fig. 3

6 - Actuator

◆ Removing and installing -> Fig. 4

7 - Vacuum hose

◆ Remove to perform leak test -> Page 96-81

8 - Connector

◆ For vacuum pump

96-44

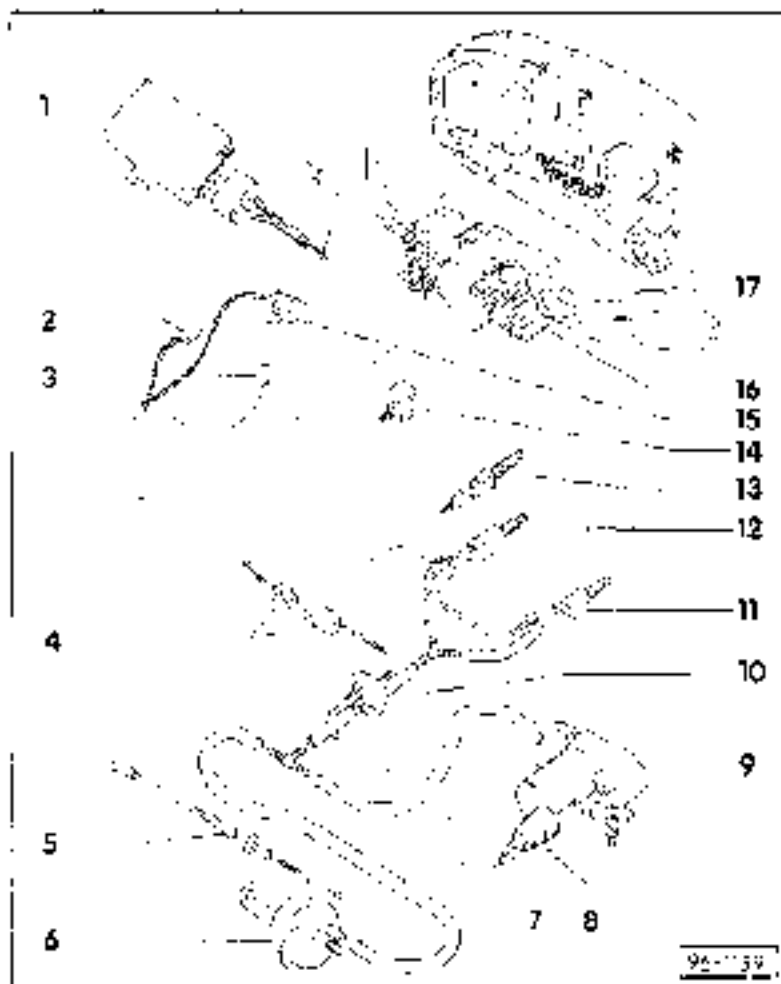

9 - Vacuum pump  
 ◆ Removal and installation, vehicles with 4 and 5 cyl. engine -> Fig. 3, vehicles with 8-cyl. engine -> Fig. 6

10 - Rubber grommet

11 - Vent valve at clutch pedal  
 ◆ Removing -> Fig. 7  
 ◆ Installing and adjusting -> Fig. 8

12 - Vent valve  
 ◆ At brake pedal  
 ◆ Removing -> Fig. 7  
 ◆ Installing and adjusting -> Fig. 8

13 - Brake light switch

96-45

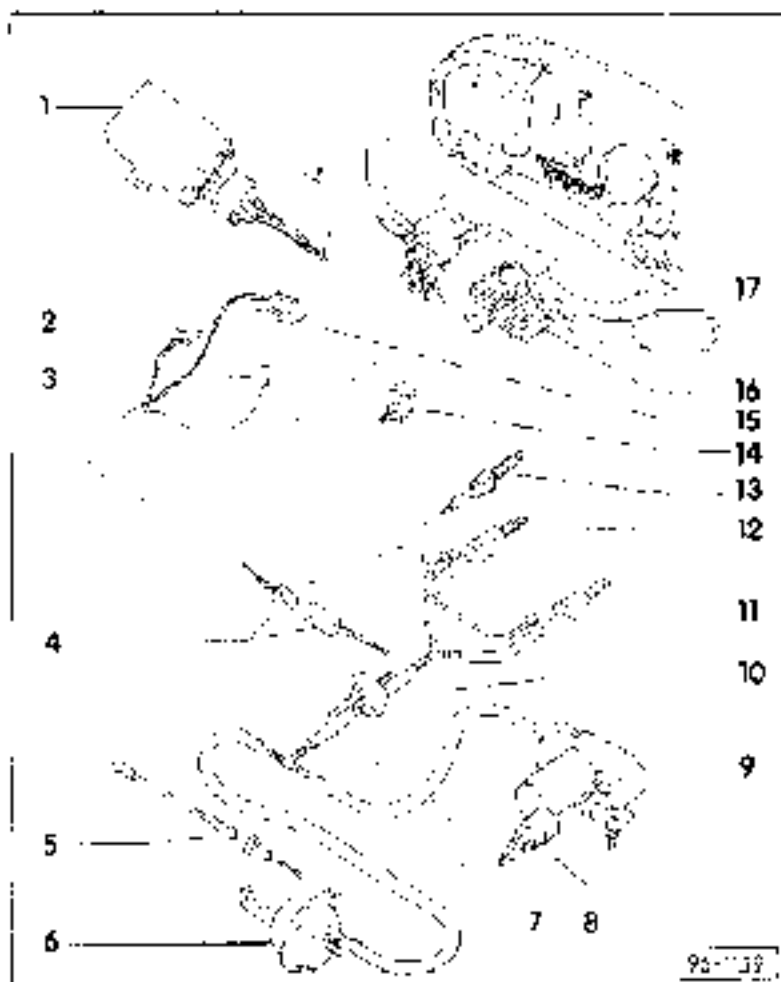

14 - 26 pin connector  
 ◆ Black  
 ◆ For cruise control switch

15 - 26-pin connector  
 ◆ Blue  
 ◆ For dash insert

16 - Steering column switch with controls for CCS.  
 ◆ Removing and installing -> Page 58-20

17 - Dash panel insert  
 ◆ Travel signal connector, blue connector, cavity 18

96-46

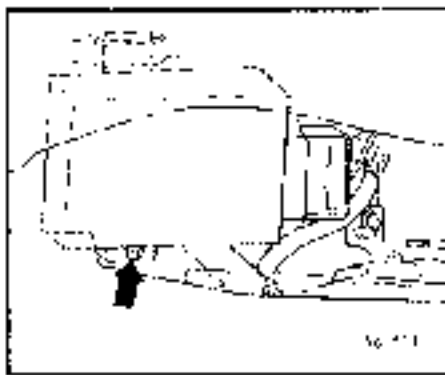

◀ **Fig.1 Removing and installing control unit**

Removing glove compartment

- > Body Assembly Work; Repair Group 70: Dash Panel; Removing and installing glove compartment =>
- Use recessed head screwdriver to detach control unit from back of instrument panel.
- Remove control unit from retainer and unplug connector.

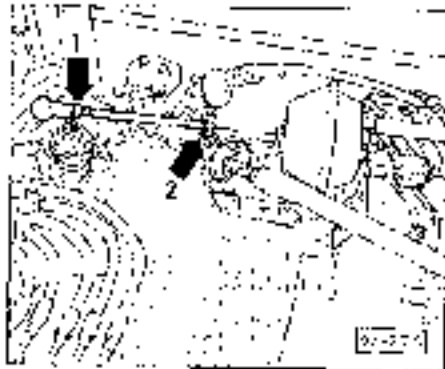

◀ **Fig.2 Adjusting linkage at actuator, vehicles with 4 and 5 cyl. engine**

Start engine.

Use nut -1- to adjust clearance between bushing and stop plate -2-.

- Specified value: 0,5 .. 1 mm

96-47

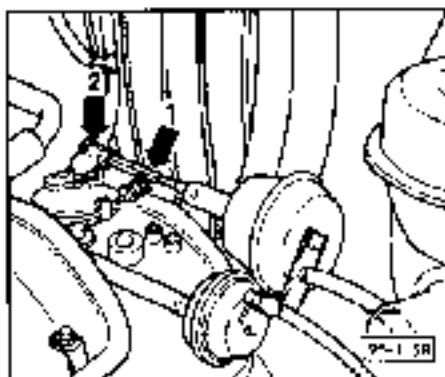

◀ **Fig.3 Adjusting linkage at actuator, vehicles with 6 - cyl.-engine**

- Start engine.

- Use nut -1- to adjust clearance between bushing and stop plate -2-.

- Specified value: 0,5 .. 1 mm

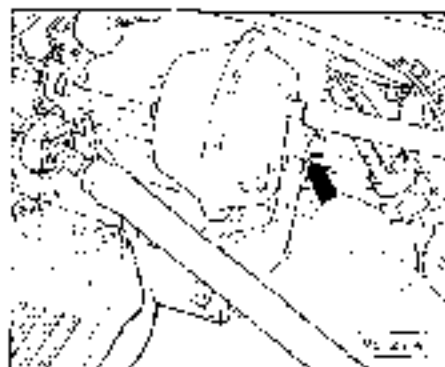

◀ **Fig.4 Removing and installing actuator**

- Unscrew linkage.

- Pull off vacuum hose.

- Unscrew actuator -arrow- from holder (25 Nm)

96-48



◀ **Fig.5 Removing and installing vacuum pump, vehicles with 4 and 5 cyl. engine**

Pull pump complete with rubber studs upwards out of bracket.

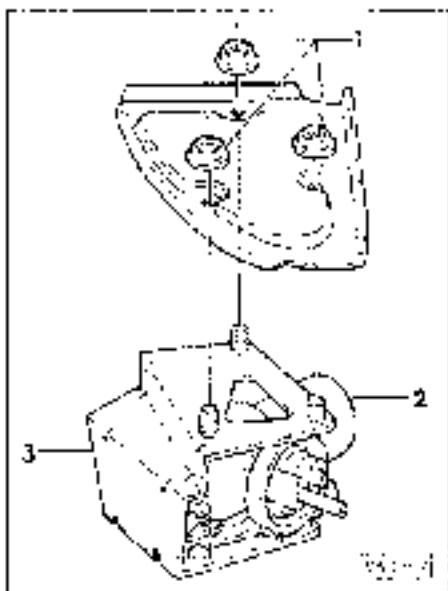

◀ **Fig.6 Removing and installing vacuum pump, vehicles with 6 cyl. engine**

Remove securing nuts 1 13 Nm.

Remove vacuum pump 2 with holder 3 from bracket.

- Pull off vacuum hose and connector, remove vacuum pump with holder from engine compartment.

- Pull vacuum pump complete with rubber studs upwards out of bracket; if necessary, position screwdriver between vacuum pump and bracket and press out vacuum pump.

96-49

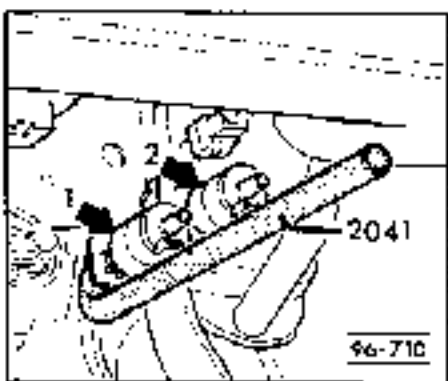

◀ **Fig.7 Removing vent valve at clutch pedal/brake pedal**

- Remove driver's side trim.

- > General body repairs, Repair group 70, Dash panel, Removing driver's storage compartment >

- Pull connector and vacuum hose off vent valve at clutch pedal - 1 / brake pedal - 2 .

- Use special tool 2041 to push vent valve out through bushing.

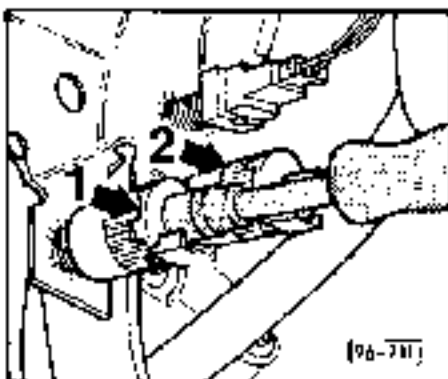

◀ **Fig.8 Installing and adjusting vent valve at clutch pedal/brake pedal**

- Place vent valve in position.

- Use 10 mm socket wrench to push home vent valve through bushing

- To adjust vent valve, pull back clutch pedal -1- / brake pedal -2- as far as it will go

96 50

## Testing vacuum system for cruise control

- Pull vacuum hose off vacuum pump.
- Push in diaphragm in positioning element.
- Seal off end of detached hose.
  - If diaphragm at actuator remains pushed in and does not move, vacuum system is OK.
  - If diaphragm returns to original position, there is a leak in the system.

### Possible cause of fault

- ◆ Vent valve leaking or incorrectly set
- ◆ Actuator leaking
- ◆ Cracks in vacuum hoses

## Servicing immobiliser

### Overview

- 1 Immobiliser control unit J362
  - ◆ Removing and installing → Page 96-54
- 2 - Immobiliser reader coil -D2
  - ◆ Integrated into steering column lock
  - ◆ -D2 reads response code of transponder each time ignition is switched on
  - ◆ Removing and installing → Page 96-55

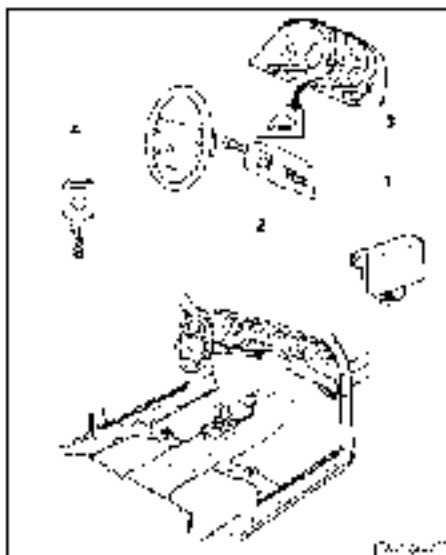

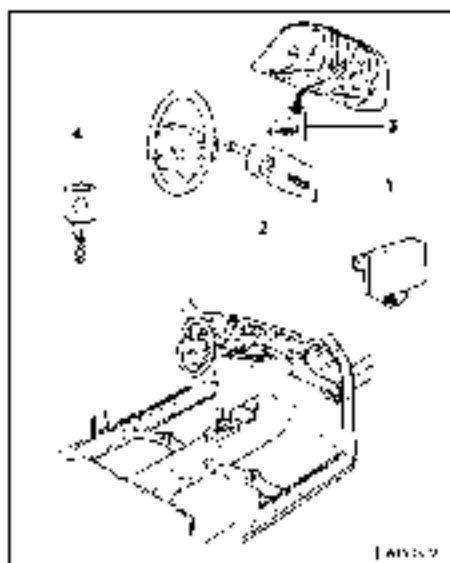

### 3 - Immobiliser warning lamp (K117)

- ◆ K117 comes on briefly when an authorised ignition key is used.
- ◆ K117 flashes continuously if an unauthorised ignition key is used, or if a system fault occurs.
- ◆ Removing and installing - > Page 90-11

### 4 - Transponder (reply storage memory)

- ◆ Integrated into ignition key
- ◆ Replace entire vehicle key if transponder defective.
- ◆ Make or order replacement key on basis of lock number
- ◆ Perform vehicle key adaptation - > Page 91-11

## Removing and installing immobiliser control unit

- Removing steering column switch - > Page 94-23
- Removing dash panel insert - > Page 90-8
- Remove driver's side tray.
- > General body repairs, Repair group 70, Dash panel, Removing driver's storage compartment - >
- ◆ - Remove securing bolts (arrows) from immobiliser control unit (1) at steering mount on right, remove control unit
- Detach multipin connector.

### Notes:

- ◆ The engine control unit identifier is read in automatically when a new immobiliser control unit is installed.
- ◆ When installing an immobiliser control unit (J362) from another vehicle, engine control unit replacement adaptation must be carried out - > Page 91-10
- ◆ Vehicle key adaptation - > Page 91-11 is then to be carried out.

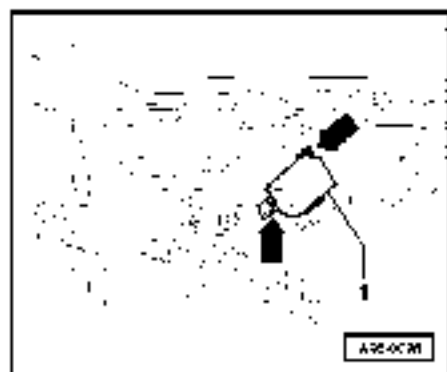



## Replacing reader coil -D2

### **Note:**

*The reader coil can only be replaced in conjunction with the steering column lock*

Removing steering column lock and lock cylinder → Page 94  
43

- Fit new steering column lock with any lock number. Do not perform door lock adaptation

### **Note:**

*The customer will have to use two different keys for vehicle during the delivery period.*

- Order new steering column lock with vehicle-specific lock number from Sales Centre/Importer.
- After delivery, replace steering column lock with the one with the vehicle-specific lock number.

## Relay plate

### Removing and installing relay plate with fuse box

**Note:**

Relay assignment, fuse assignment and ratings, allocation of contact designations, assignment of self-diagnosis connectors

=> "Current Flow Diagrams, Electrical Fault Finding and Fitting Locations" binder

- 1 - Cover
- 2 - Fuse assembly tool
  - ◆ Attached to cover

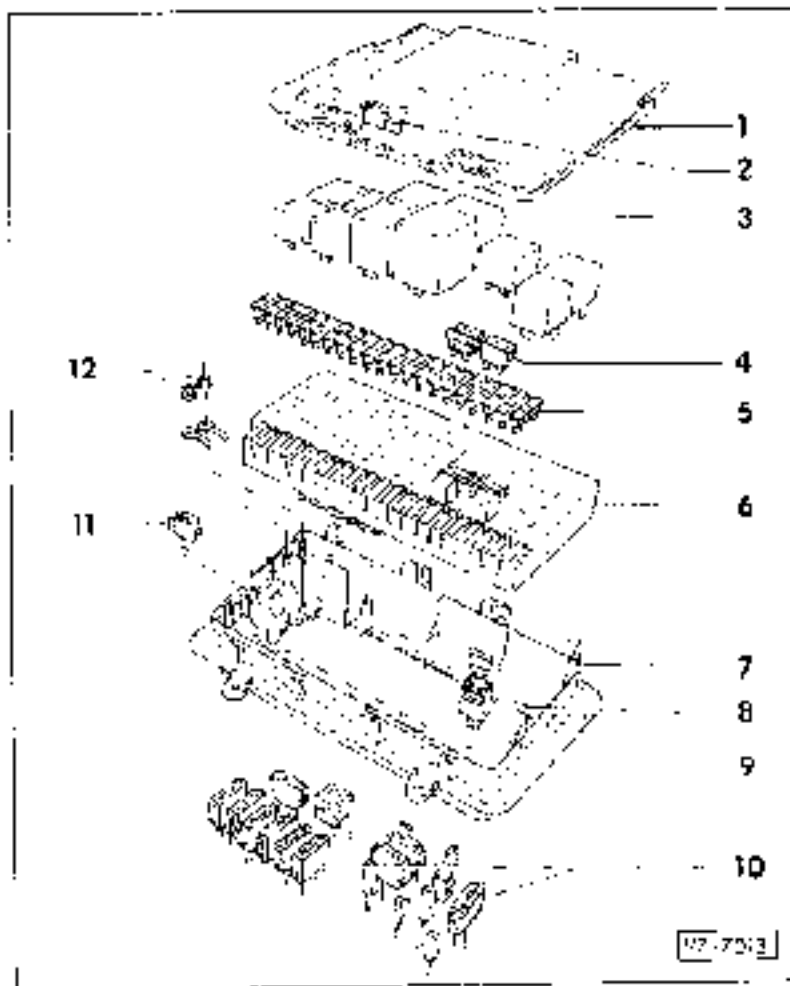

97-1

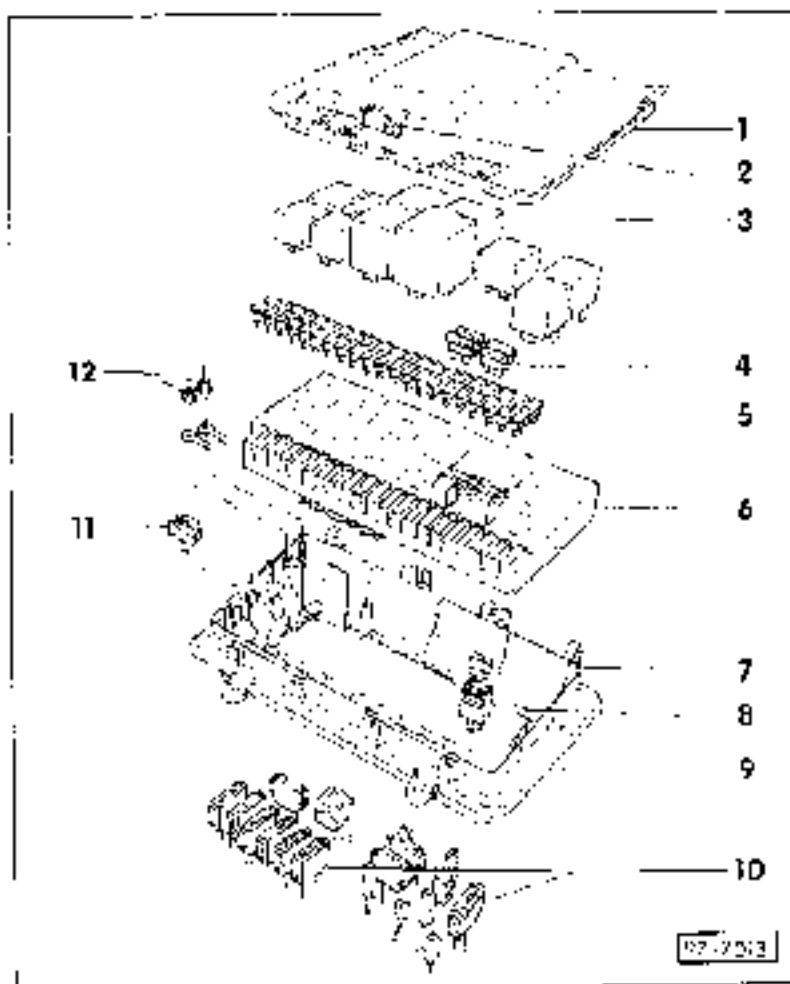

- 3 - Relay
- 4 - Spare fuses
- 5 - Fuses
  - ◆ Removing => fig. 1
- 6 - Relay plate with fuse box
- 7 - Additional fuses
- 8 - Additional fuse adaptor
  - ◆ Removing and installing -> Page 11-5
- 9 - Housing

97-2

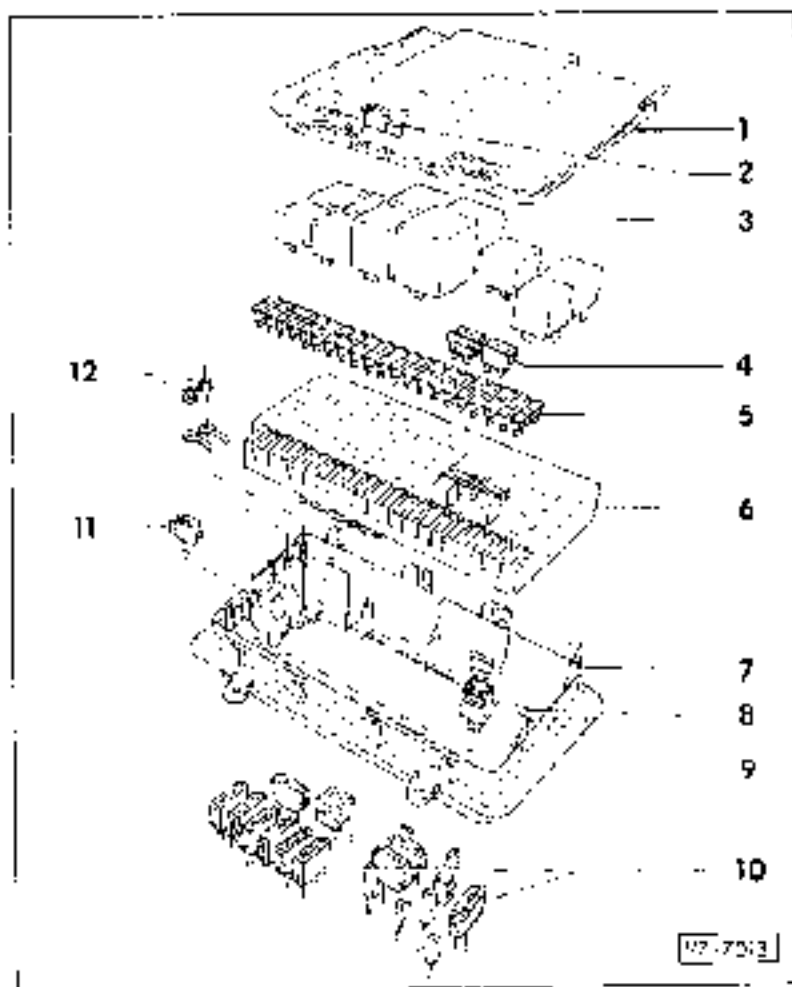

- 10 - Plug housing
  - ◆ Pulling off - > Fig. 2
  - ◆ Assignment - > Page 97-9
- 11 - Self-diagnosis connector
- 12 - Combination nut M5

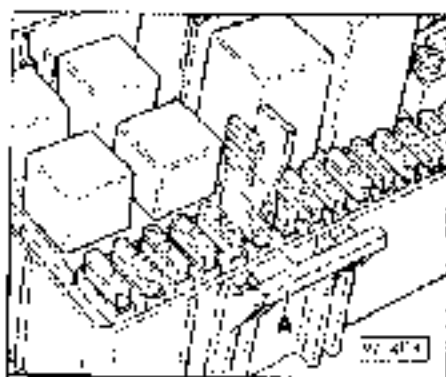

- ◀ **Fig.1 Removing fuses**
  - A - Fuse assembly tool, attached to cover
  - Place tool over fuse and pull fuse out of holder.

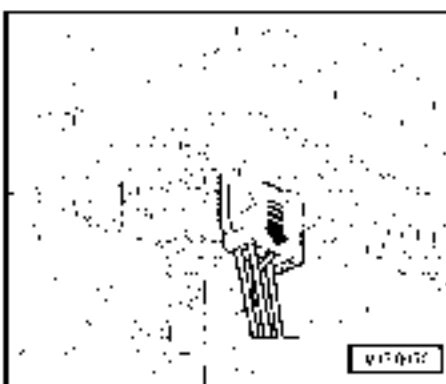

- ◀ **Fig.2 Pulling off plug housing**
  - To detach connectors, grip plug housings firmly and pull off.
  - If this is not possible, pull carefully on wiring loom as well.

## Removing and installing additional fuse adapter

### Removal:

- Lift cover for relay plate in plenum chamber and remove
- Remove relay plate upwards; leave all connectors attached.
- ◀ - Pull out fuse.
- Press in catch using small screwdriver

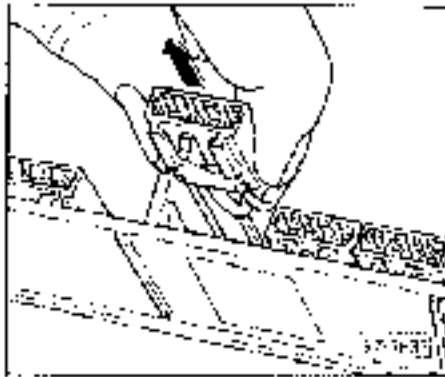
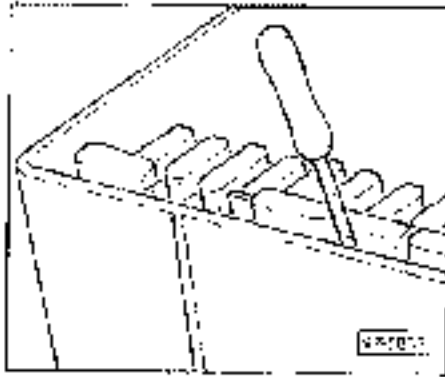

- ◀ - Pull additional fuse adapter off upwards.

— 97-5 —

### Installation:

- Insert additional fuse adapter from top until catch (arrow) can be heard to engage
- Push in fuse
- Push in relay plate.

### Note:

*Take care not to crush any connecting leads when pushing in.*

- Attach cover and make sure that it is properly closed (to prevent water from entering).

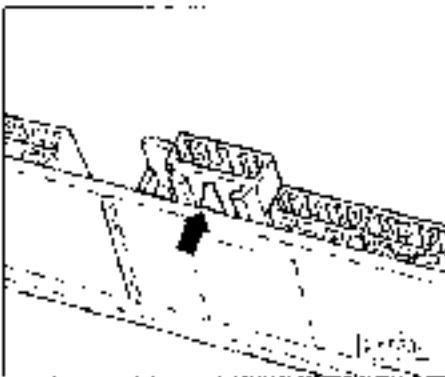

— 97-6 —

Wiring loom connections

- A Air conditioner
- B Front right
- C - Instrument panel
- D - Front left
- E - Front left
- F Instrument panel
- G - Instrument panel
- H - Rear
- I - Instrument panel
- J - Instrument panel

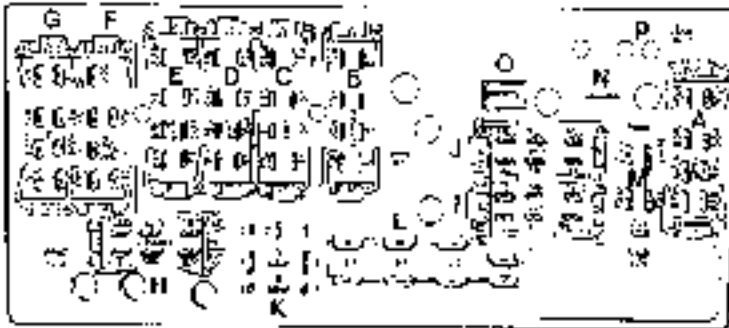

97-417

97-7

- K Connection, relay position 3
- L - Single connector, terminal 30
- M - M-Options
- N - Output, glow-plug strip fuse
- O - Output, intake manifold preheating
- P Output, fuse 20

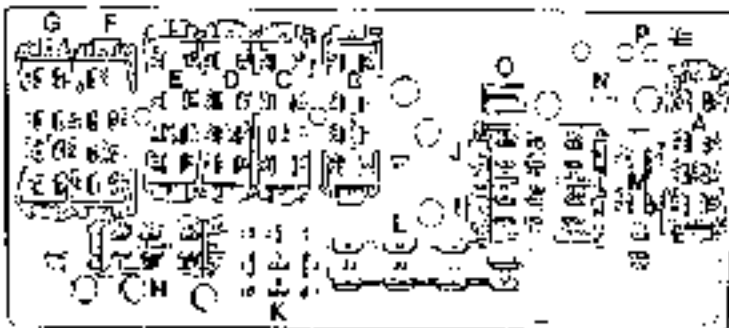

97-418

97-6

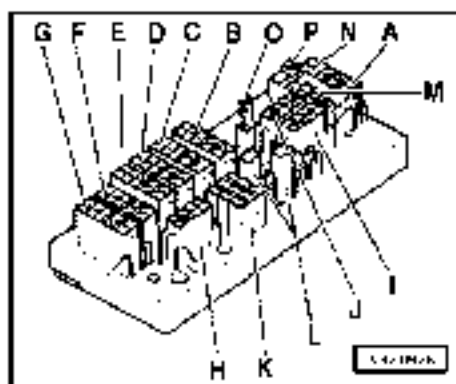

#### Plug housing assignment

Terminal	Plug housing colour	Connection
A	Grey	8-pin
B	Black	8-pin
C	Blue	8-pin
D	green	8-pin
E	Yellow	8-pin
F	Brown	8-pin
G	red	8-pin
H	Black	8-pin
I	red	8-pin
J	Yellow	8-pin
K	Black	9-pin
L	Black	single
M	coloured	single
N	coloured	single
O	Black	single
P	red	single

l at contacts /b ak. /b as. /b s. 30 ac. 30 az

97-9

#### Removing and installing auxiliary relay carrier with connector point



- Remove driver's side tray.
- > General body repairs; Repair group 70; Dash panel, Removing driver's storage compartment >
- Remove fastening screws -arrows- and pull relay carrier downwards.

97-10

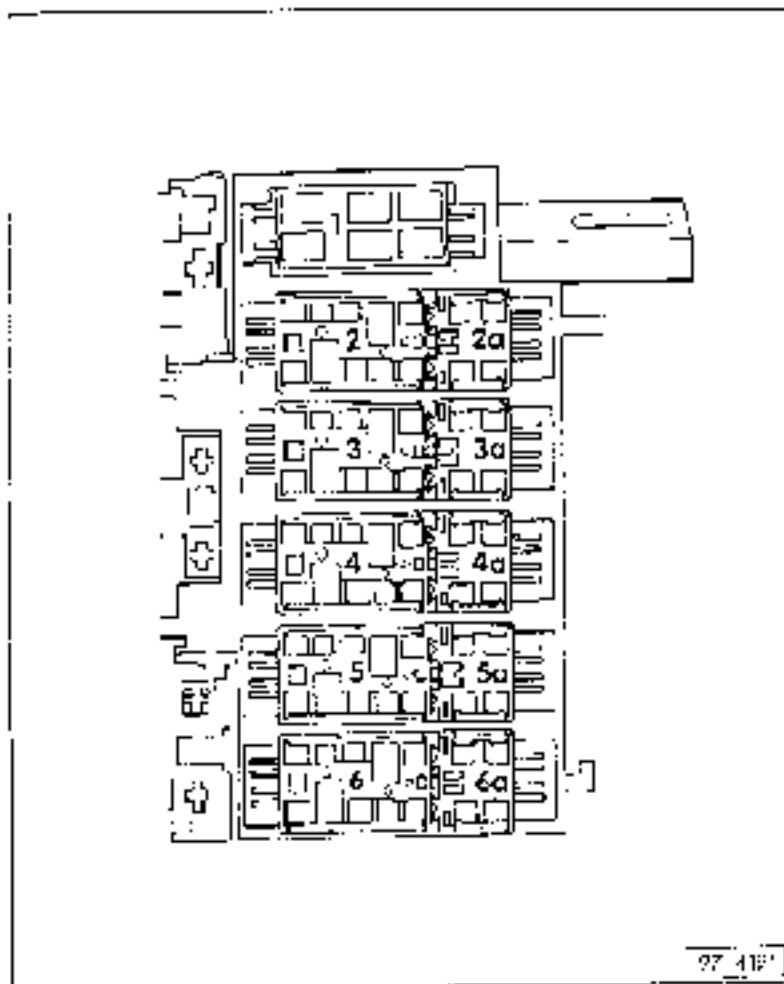

Arrangement of connectors in connector point

Notes:

- ◆ Use appropriate current flow diagram.
- > "Current Flow Diagrams, Electrical Fault Finding and Fitting Locations" binder
- ◆ Various wiring looms for options have not been fitted, there will be an empty housing at this point.
- 1 - Wiring loom, wiper motor (black)
- 2 - Wiring loom, automatic gearbox (green)
- 2a - Wiring loom, AC compressor (green)

97-11

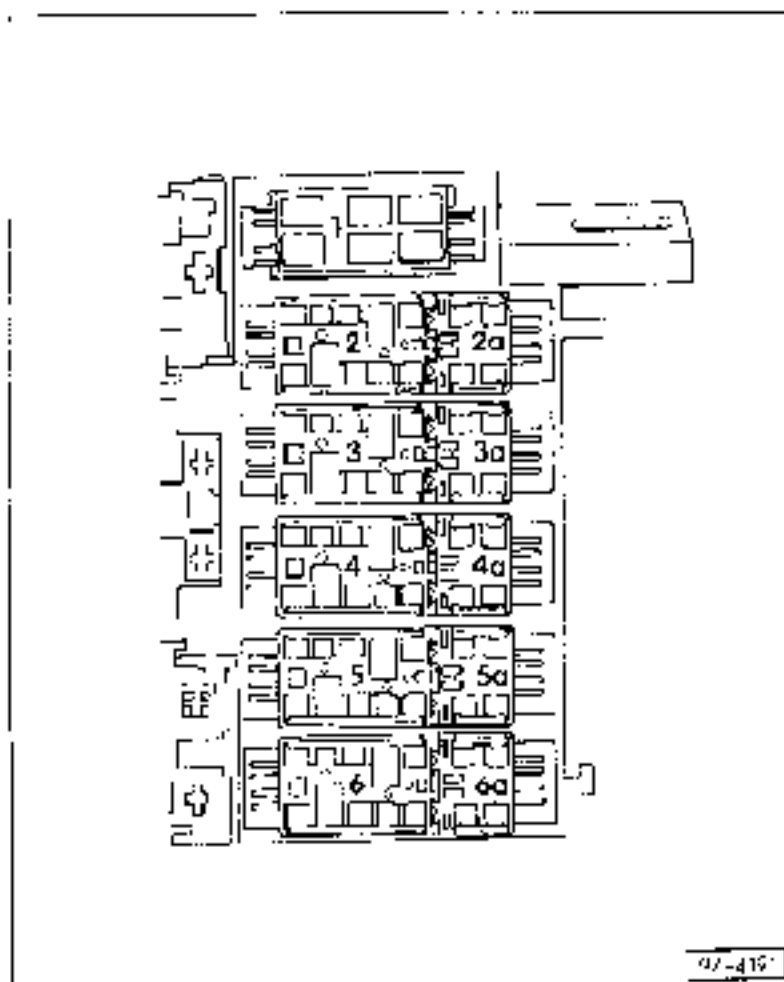

- 3 - Wiring loom, front left (yellow)
- 3a - Wiring loom, seat heating (yellow)
- 4 - Wiring loom, ABS (blue)
- 4a - Wiring loom, cruise control system (blue)
- 5 - Wiring loom, rear (brown)
- 5a - Wiring loom, door contact switch (brown)
- 6 - Wiring loom, front right (black)
- 6a - Wiring loom, front right (black)

97-12