



Audi 1.4l TFSI Engine with Dual Charging

The 1.4l 136kW TFSI engine is a top-of-the-range addition to the Audi A1 series.

The combination of a Roots blower and exhaust gas turbocharging is reflected in spontaneous throttle response and high pulling power, even at high driving speeds.

The Roots blower cuts in at 1500 rpm and, in most situations, cuts out again at 2400 rpm.

At the latest by 3500 rpm, the turbocharger does all the work.

Since it has little work to do at low engine speeds, the Roots blower is large in size and designed for high efficiency.

Thanks to *TFSI** technology, which combines efficiency and dynamics, all Audi models featuring the new 1.4l 136 kW TFSI engine continue Audi's successful concept of *downsizing**.

In the Audi A1, the engine consumes on average just 5.9 litres of fuel per 100 km. Specific power output is 97.8 bhp per litre, yet CO₂ emissions are only 139 g/km.

Petrol direct injection, the Roots blower and the turbocharger make for a perfect combination. The engine is rated for a high compression ratio of 10.0 : 1. This enhances thermodynamics, resulting in increased power output and economy.

The three-door Audi A1 with 1.4l 136kW TFSI engine sprints from zero to 100 kph in 6.9 seconds and has a top speed of 227 kph.



491_002

Learning objectives of this Self Study Programme:

In this Self Study Programme you will learn about the technology of the 1.4l 136kW TFSI engine.

When you have worked your way through this Self Study Programme, you will be able to answer the following questions:

- ▶ How is the basic engine designed?
- ▶ What are the differences between the 1.4l 136kW TFSI engine and the TFSI engines used previously by Audi?
- ▶ How does the engine's air supply system work?
- ▶ What are the points to note when servicing the vehicle?

Introduction

Specifications	5
----------------	---

Engine mechanicals

Cylinder block	6
Crank mechanism	7
Poly V-belt drive	8
Chain drive	9
Cylinder head	10
Crankcase ventilation	12

Oil supply

Oil circuit	14
Oil pump	15
Oil filter	15

Air supply

System overview	16
Operating ranges of the twin charging system	17
Twin charging with Roots blower and exhaust gas turbocharger	20
Components of the exhaust turbocharging system	21
Roots blower	22
Drive	22
Function	24
Sensors and actuators	26
Charge air cooling	29

Exhaust system

Overview	30
----------	----

Cooling system

Dual-circuit cooling system	31
-----------------------------	----

Fuel system

System overview	33
-----------------	----

Engine management

System overview of the 1.4l 136kW TFSI engine	34
---	----

Sound actuator system

Introduction	36
System overview	37
Diagnostics	38

Service

Sight glass for seals	39
Maintenance operations	40

Annex

Glossary	41
Test your knowledge	42
Self Study Programmes	43

► The Self Study Programme teaches a basic knowledge of the design and functions of new models, new automotive components or new technologies.

It is not a Repair Manual! Figures are given for explanatory purposes only and refer to the software version valid at the time of preparation of the SSP.

For maintenance and repair work, always refer to the current technical literature.

Terms written in italics or indicated by an asterisk are explained in the glossary at the back of this Self Study Programme.



Note



Reference

Introduction

Brief technical description

- ▶ Bosch Motronic MED 17.5.5
- ▶ Homogeneous mode ($\lambda = 1$)
- ▶ Twin-injection catalytic converter heating
- ▶ Exhaust gas turbocharging with *wastegate**
- ▶ Active mechanical Roots blower charging
- ▶ Charge air cooling
- ▶ Maintenance-free chain drive
- ▶ Plastic intake manifold
- ▶ Continuously variable intake camshaft timing
- ▶ Cast iron cylinder block
- ▶ Steel crankshaft
- ▶ Dual-circuit cooling system
- ▶ Demand-controlled fuel system
- ▶ High-pressure fuel pump capable of delivery pressures up to 100 bar



491_003



Reference

For further information about the Audi TFSI technology, refer to Self Study Programmes 432 "Audi 1.4l TFSI engine" and 384 "Audi chain-driven 1.8l 4V TFSI engine".

Specifications

Torque-power curve

1.4l 136kW TFSI engine CAVG

— Power in kW

— Torque in Nm

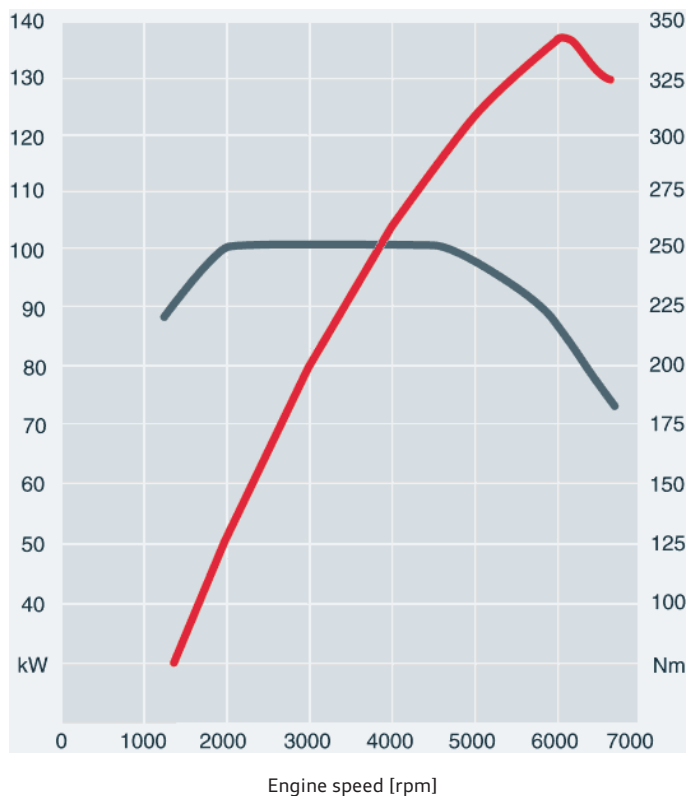

491_011

Engine code	CAVG
Type	Four-cylinder inline engine
Displacement in cm ³	1390
Stroke in mm	75.6
Bore in mm	76.5
Number of valves per cylinder	4
Firing order	1-3-4-2
Compression ratio	10.0 : 1
Powertrain type	Seven-speed S tronic with front wheel drive
Power output in kW at rpm	136 at 6200
Torque in Nm at rpm	250 at 2000 – 4500
Fuel	Premium unleaded (98 RON) ¹⁾
Engine management	Bosch Motronic MED 17.5.5 (UDS control unit) Operating modes: homogeneous mode, twin-injection catalytic converter heating
Emissions standard	EU V
CO ₂ emission in g/km	139
Exhaust gas aftertreatment	Three-way catalytic converter with lambda control
Vehicle use	A1

¹⁾ 95 RON unleaded premium fuel may also be used, with slight loss of power.

Engine mechanicals

Cylinder block

The cylinder block of the 1.4l 136kW TFSI engine is die cast with lamellar graphite. This ensures sufficient operational reliability under the high combustion pressures which build up inside the TFSI engine. Since the lamellar graphite cast iron cylinder block is stronger than a die-cast aluminium cylinder block, the crankshaft may be removed.

As was previously the case with the 1.2l 63kW TFSI engine, 1.2l 77kW TFSI engine and 1.4l 92kW TFSI engine, the cylinder block is of *open-deck design**. This means that there are no cross-members between the outer wall and the cylinder tubes.

This has two advantages:

- ▶ It prevents the formation of air bubbles which, in a dual-circuit cooling system in particular, would cause ventilation and cooling problems.
- ▶ In the case of the threaded connection between the cylinder head and cylinder block, cylinder tube deformation is less pronounced and more uniform than in a closed-deck design with cross-members due to the separation between the cylinder tube and the cylinder block. This reduces oil consumption since the piston rings are able to better compensate for such deformation.

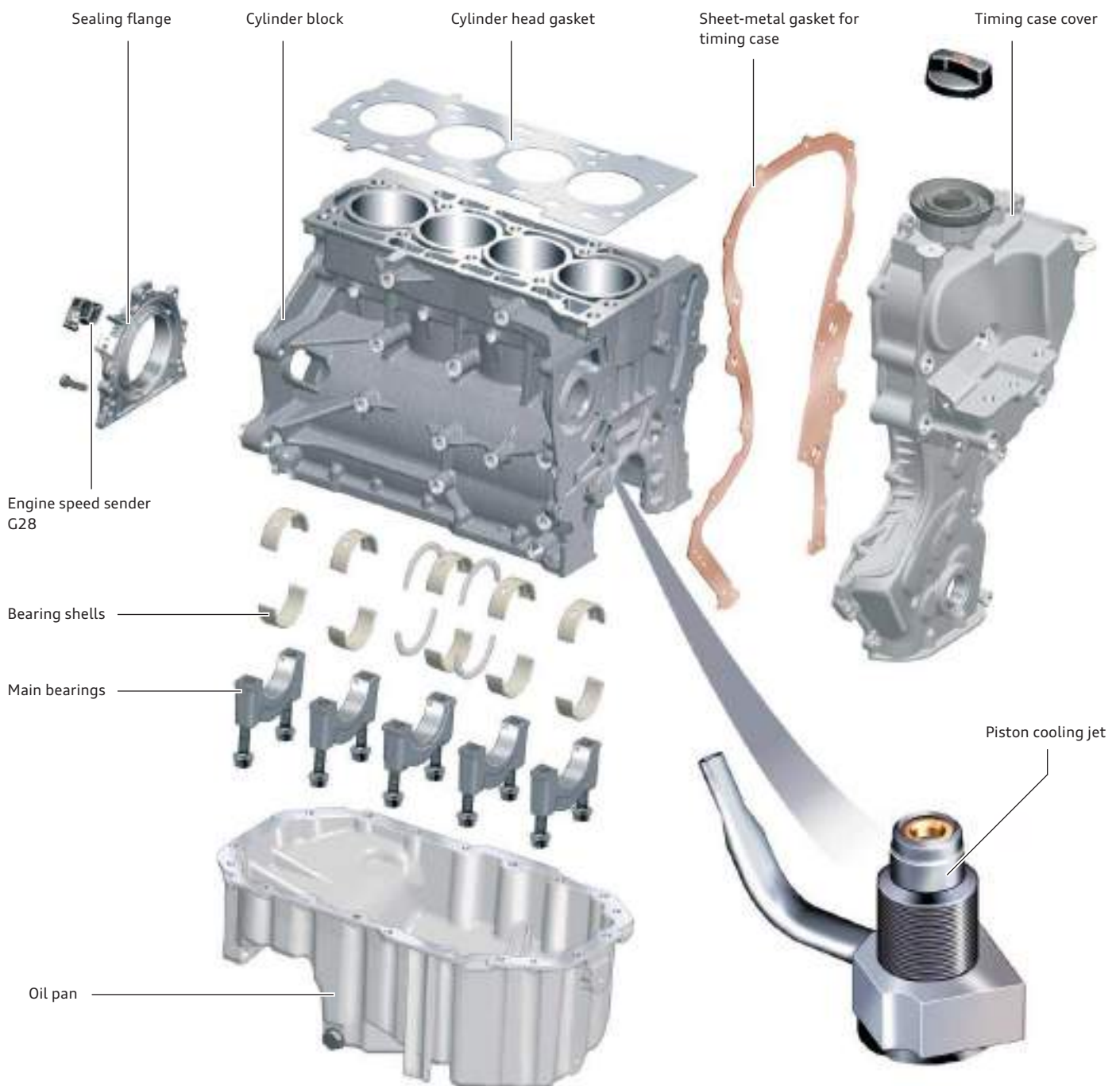

491_001

Crank mechanism

Crankshaft

The forged steel crankshaft runs on five bearings. The main bearing 3 is designed as a thrust bearing and constrains the axial play of the crankshaft.

The sprocket is mounted on the timing side.

Conrods

The conrods of the 1.4l 136kW TFSI engine are designed as cracked conrods. The small-end conrod bearing shells are a composite of three materials, while the big-end conrod bearing shells are made of two materials. The conrod bush is made of bronze.

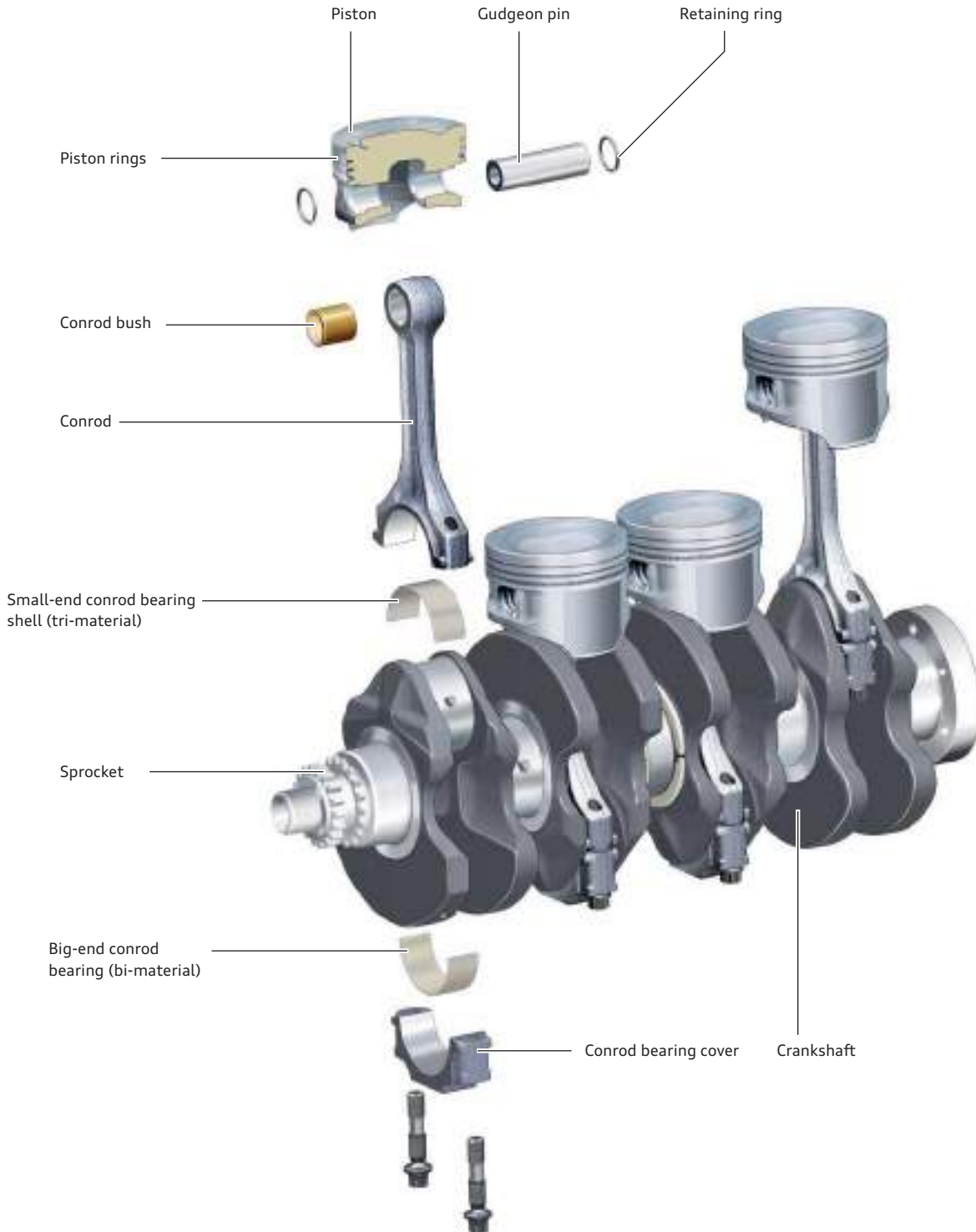

491_007



Reference

For further information about the design of the crank mechanism, refer to Self-Study Programme 432 "Audi 1.4l TFSI Engine".

Poly V-belt drive

The 1.4l 136kW TFSI engine has two poly V-belts.

- ▶ The belt drive for the auxiliary units has a six-groove poly V-belt which drives the coolant pump, the alternator and the AC compressor via the crankshaft pulley.
- ▶ The Roots blower belt drive has a five-groove poly V-belt which drives the Roots blower via the solenoid coupling pulley when the solenoid coupling is engaged.

Proper tensioning is ensured by two tensioning rollers in the belt drive for the auxiliary units and by a single tensioner pulley in the Roots blower belt drive. The crankshaft belt drive tensioner pulley also ensures proper fitting of the poly V-belt around the crankshaft pulley and the coolant pump pulley.

Overview

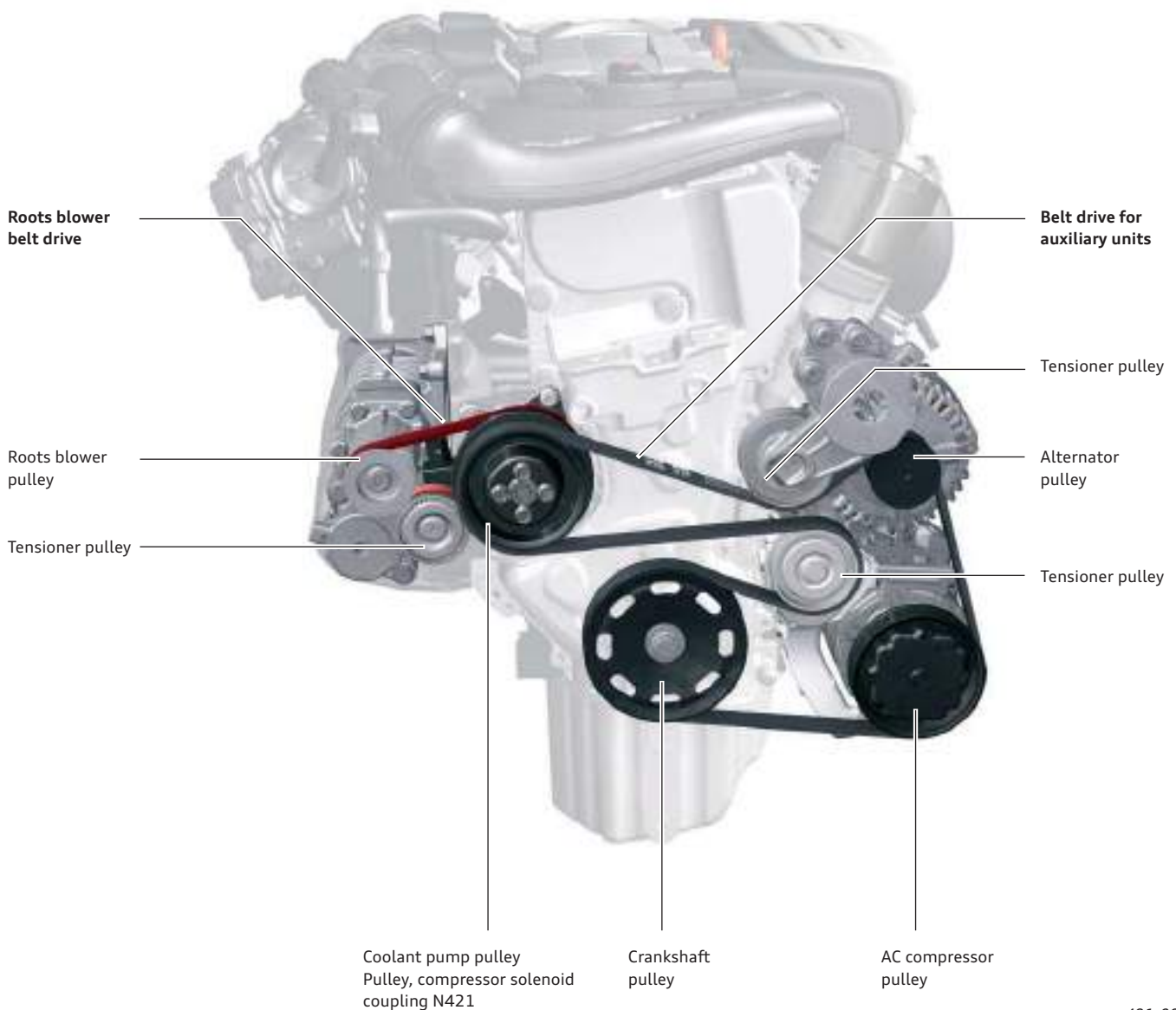

491_006

Chain drive

Both the camshafts and the oil pump are driven by the crankshaft via a maintenance-free chain drive.

Camshaft drive mechanism

The toothed chain drive has been optimised to handle the higher loads. The toothed chain has hardened pins and heavier duty links which have been adapted to withstand the forces acting on the chain.

The chain is tensioned by a mechanical/hydraulic chain tensioner.

Oil pump drive

The oil pump drive has a toothed chain with 8 mm pitch for optimised acoustics.

Tension is produced by a spring-loaded chain tensioner.

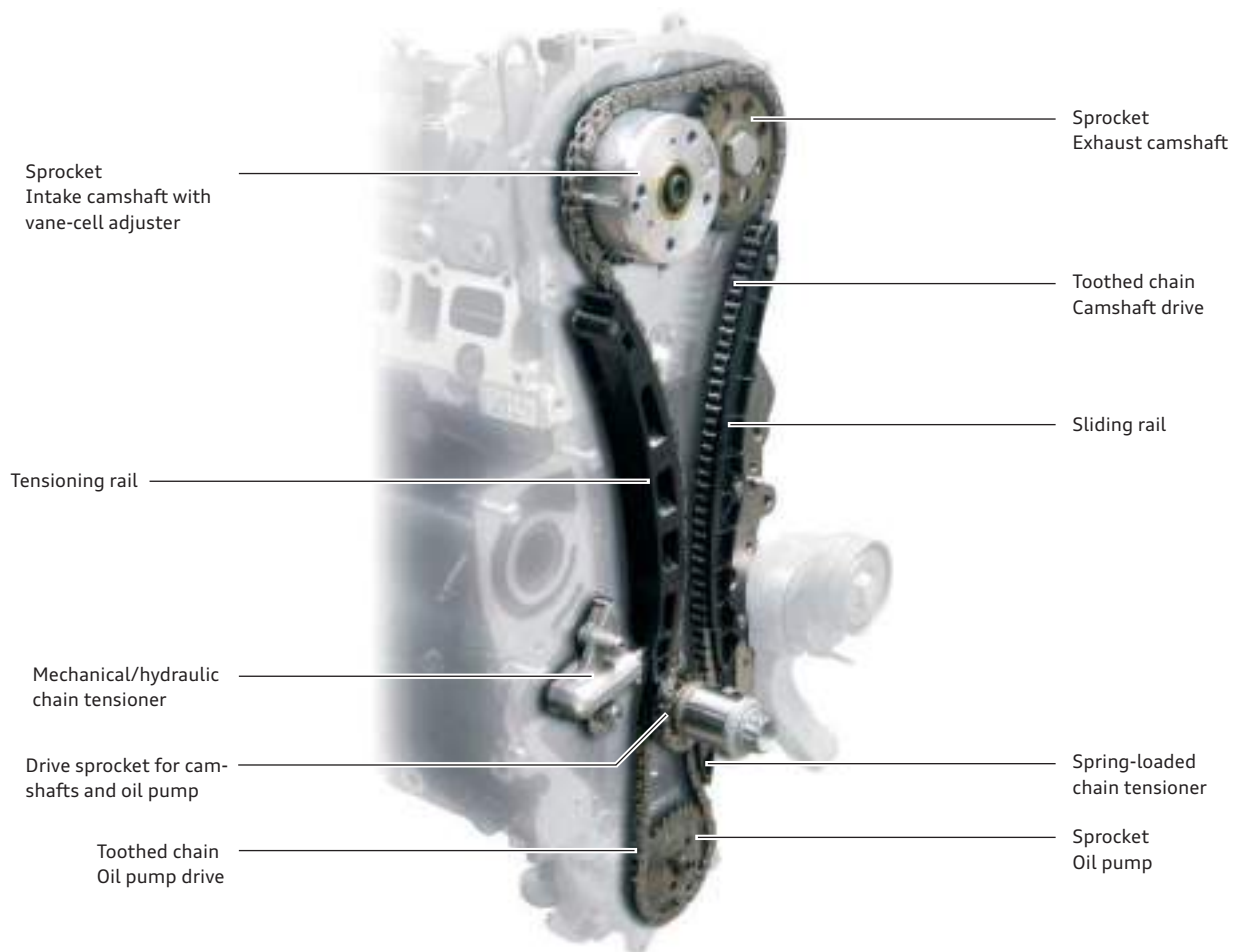

491_012

Variable camshaft timing

Continuously variable intake camshaft timing is provided a vane cell adjuster, which adjusts the phasing angle according to engine load and speed requirements. The maximum range of adjustment is 40 crank degrees.

The advantages of variable camshaft timing are:

- ▶ excellent internal exhaust gas recirculation and
- ▶ improved torque characteristics.

Cylinder head

The cylinder head derives from the 1.4l TFSI engine. It has the following basic features:

- ▶ Aluminium cylinder head with twin composite camshafts
- ▶ Four valves per cylinder
- ▶ Three-ply metal cylinder head gasket
- ▶ High-pressure fuel pump is bolted onto the cylinder head cover
- ▶ Cast aluminium cylinder head cover
- ▶ Cylinder head cover is sealed off from the cylinder head by means of liquid sealant

Valve drive

The valves are actuated by roller-type cam followers with stationary hydraulic valve lifters. The intake and exhaust valves are identical in design. The exhaust valve has a larger valve disc. Other features are:

- ▶ Simplex valve springs
- ▶ Continuously variable intake camshaft adjustment based on the working principle of the vane cell adjuster with an adjustment range of 40 crank degrees; the camshaft is locked in the retard position at engine shut-off.
- ▶ Camshaft adjustment valve 1 N205 is bolted into the cylinder head cover from above.
- ▶ Hall sender G40, bolted into the cylinder head cover from above, checks the adjustment of the intake camshaft and recognises cylinder no. 1
- ▶ The high-pressure fuel pump is driven by the intake camshaft by means of a four-lobe cam
- ▶ The camshaft runs on three bearings (plain bearings) in the cylinder head cover, and axial play is limited by the sealing covers and the cylinder head cover

The legend of the figure is on page 11:

1	Injectors N30 – N33	15	Roller tappet
2	Closure cap	16	High-pressure fuel pump
3	Oil screen	17	Exhaust camshaft
4	Exhaust valve	18	Closure cap
5	Exhaust valve guide	19	Intake camshaft
6	Valve stem seals	20	Support element
7	Valve spring retainer	21	Roller-type cam follower
8	Valve cotters	22	Valve spring retainer
9	Variable camshaft timing	23	Valve spring
10	Camshaft sprocket	24	Intake valve guide
11	Intake camshaft timing adjustment valve -1- N205	25	Intake valve
12	Cylinder head cover	26	Oil pressure switch F1
13	Cylinder flange screws	27	Cylinder head bolt
14	Hall sender G40	28	Cylinder head

Components on the cylinder head

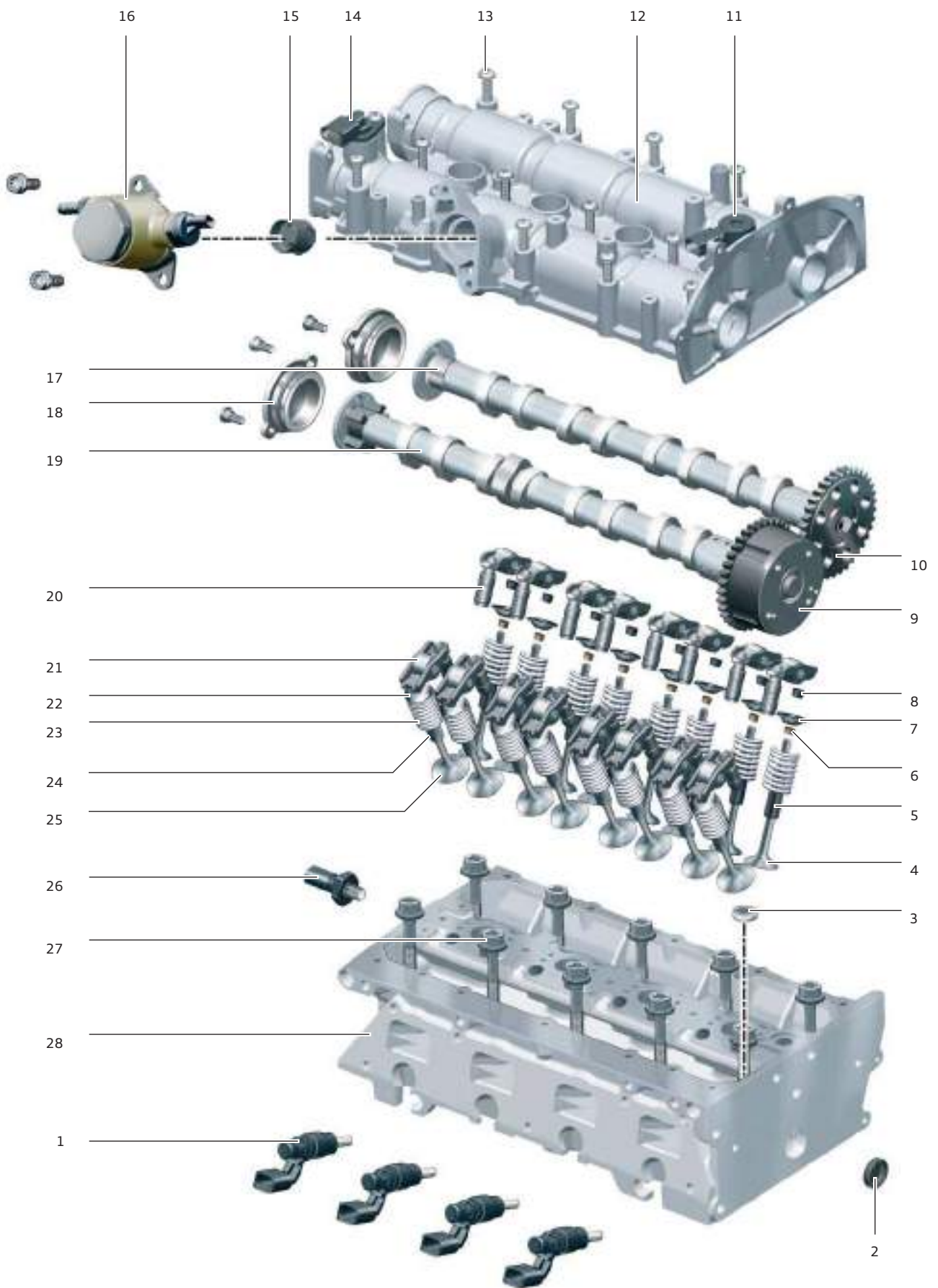

Crankcase ventilation

Crankcase breather

The crankcase breather aerates the crankcase and thus reduces the formation of water in the oil.

The crankcase is ventilated by a hose running from the air filter to the camshaft housing.

Crankcase breather

The crankcase breather of a turbocharged engine is more complex than that of a standard naturally aspirated engine.

Whereas negative pressure is permanently present inside the intake manifold of a naturally aspirated engine, the pressure in the TFSI engine can be as high as 2.5 bar (absolute).

Intake air infeed

The *blow-by gases** flow from the timing case to the nonreturn valve for crankcase ventilation.

Depending on whether the lower pressure exists in the intake manifold or upstream of the throttle valve control unit, the nonreturn valve opens and allows the gases to pass. The gases mix with the intake air inside the intake manifold or upstream of the throttle valve control unit, and are admitted to the combustion chamber.

A flow restrictor in the connecting hose to the intake manifold limits through-flow if the vacuum inside the intake manifold is too high. Consequently, there is no need for a pressure regulating valve.

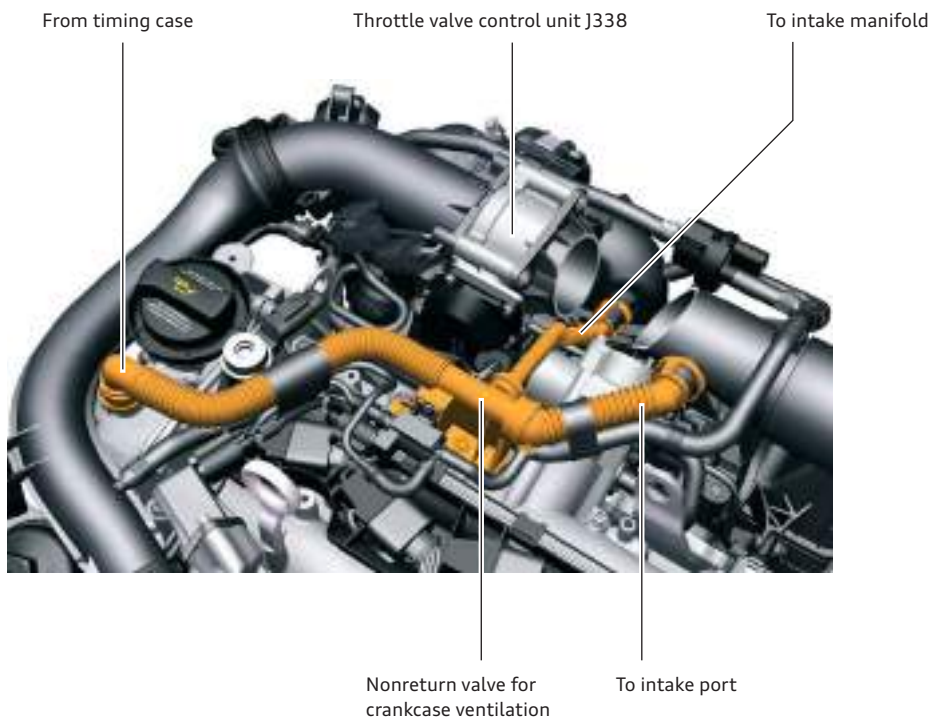

491_017

Oil separation

The blow-by gases must be separated from all entrained oil before they are introduced into the combustion chamber. This treatment process takes place inside the oil separator.

The oil separator is a module bolted to the timing case cover in which the gases flow through a labyrinth. The heavy oil droplets deposit on the walls and collect in the oil return line.

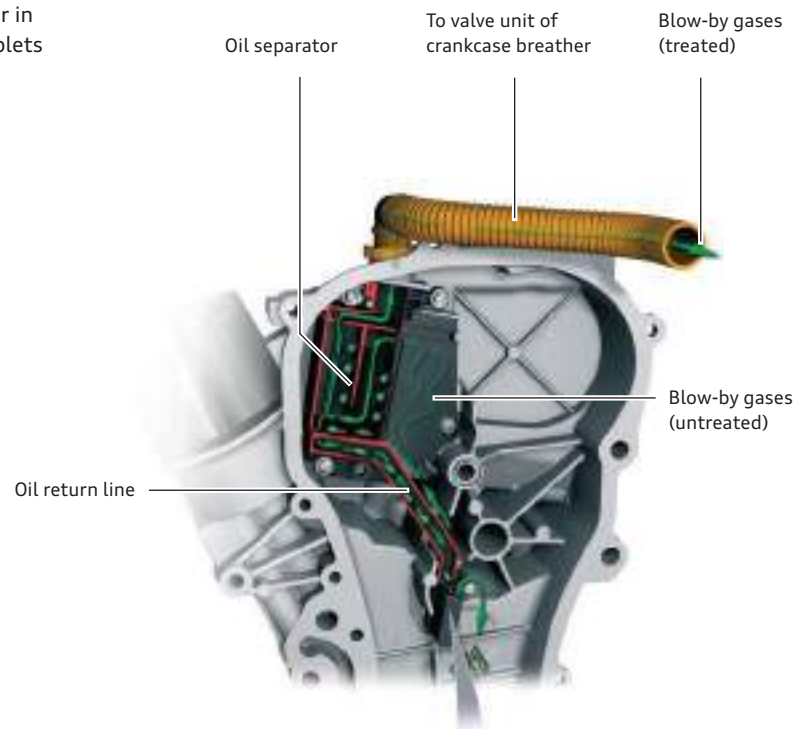

Oil return line

The oil return line is located at the bottom end of the oil separator where it has a collection chamber shaped like a siphon. This prevents blow-by gases from reaching the intake side of the engine untreated.



491_005

Oil collection chamber (siphon)



Reference

For further information about the crankcase ventilation system, refer to Self-Study Programme 432 "Audi 1.4l TFSI Engine".

Oil supply

Oil circuit



The oil circuit is identical to that of the 1.4l 92kW TFSI engine, the only distinction being that a fixed-displacement oil pump is employed.

The pressure regulation system of this pump helps to keep the oil pressure as constant as possible while the engine is running at above idle speed.

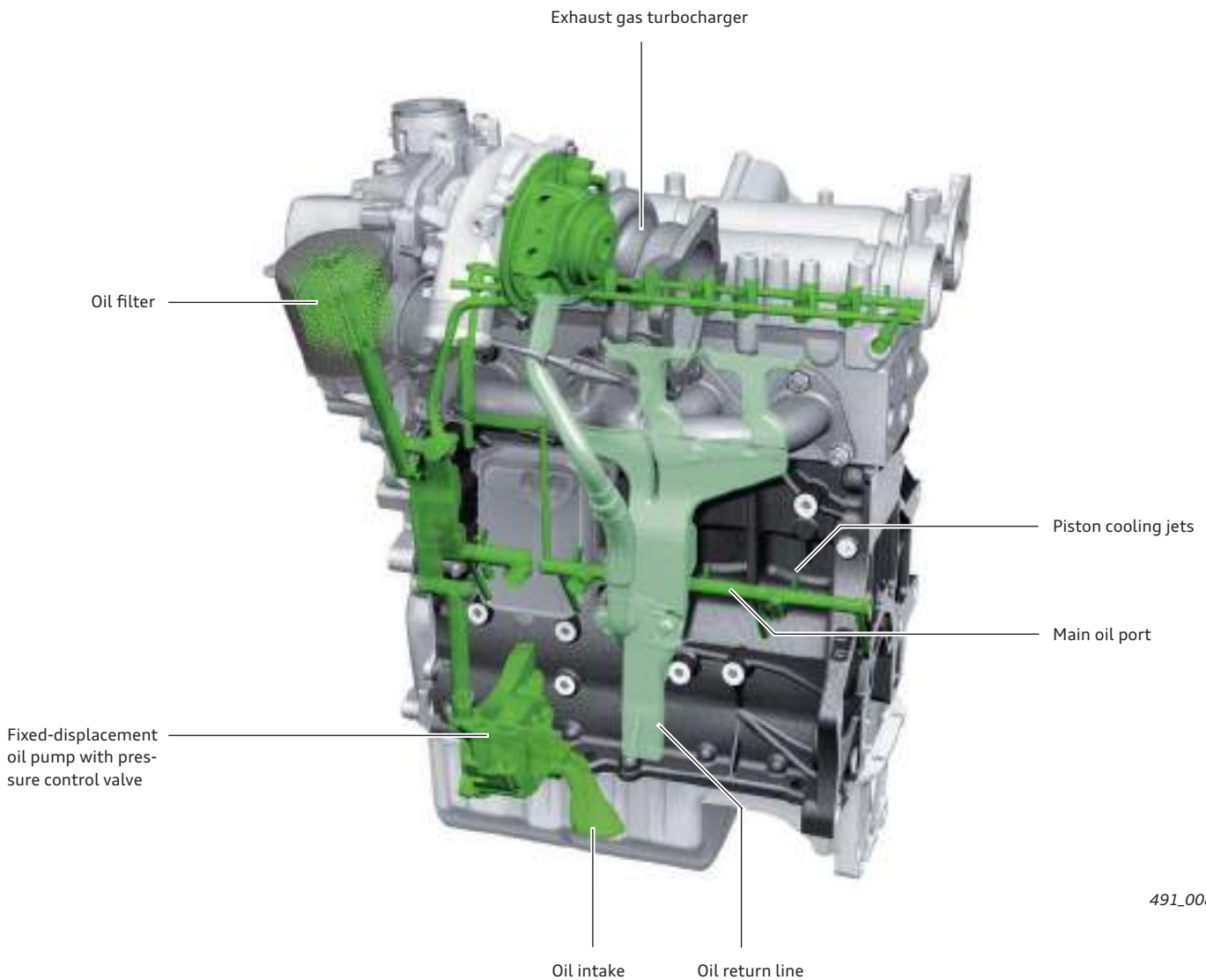
Pressure is regulated by a control piston integrated in the oil pump. This ensures that sufficient oil pressure is always available in the engine regardless of oil filter load.



491_008

-  Oil feed
-  Oil return line



Reference

For further information about the design and function of the Duocentric oil pump and the oil filter module, please refer to Self Study Programme 432 "Audi TFSI engine".

Oil pump

The 1.4l 136kW TFSI engine employs a Duocentric oil pump configured as a fixed-displacement oil pump. This pump is mounted to the bottom of the cylinder block and driven by the crankshaft via a maintenance-free toothed chain drive.

To minimise friction, the Duocentric pump is configured as a sump-oil pump and runs at a lower speed (ratio = 0.79) than the crankshaft.

Oil pressure is regulated by a spring-loaded control piston integrated in the oil pump. The pressure control valve opens at a pressure of 4 ± 0.5 bar. The diverted oil flows back into the oil pan.

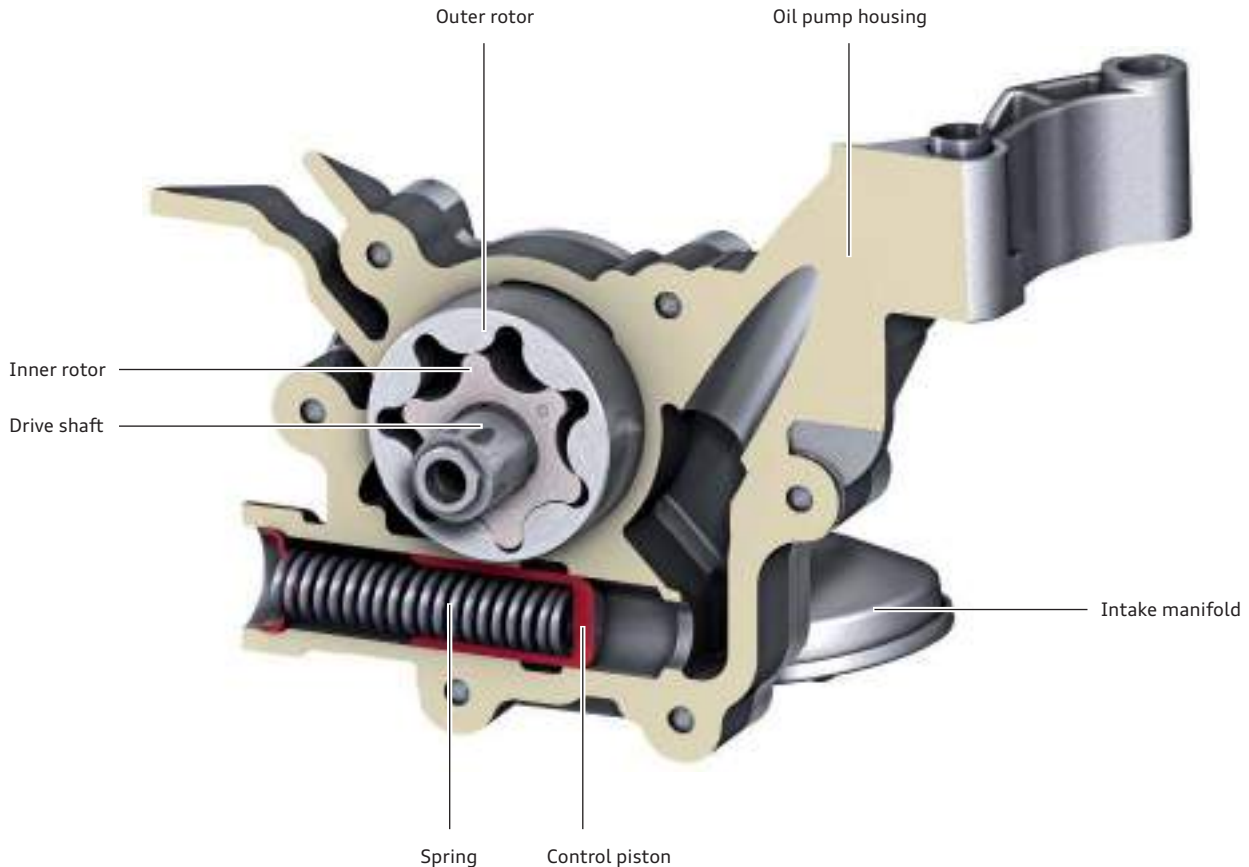

491_016

Oil filter

Like in the 1.4l 92kW TFSI engine, the 1.4l 136kW TFSI engine employs a filter module fitted with an oil filter cartridge.

The oil filter cartridge is accessible from above to allow easy servicing. To ensure that no oil drips down onto the engine when replacing the oil filter, a return channel in the timing case cover opens when the filter cartridge is released. This allows the oil to flow directly back into the oil pan.

This channel, when screwed into place, is sealed by a spring-loaded gasket. The valves inside the filter cartridge are sealed in such a way that no oil can escape after the cartridge has been removed.

Notes on filter replacement:

- ▶ First unscrew the oil filter cartridge approx. 2 – 3 turns.
- ▶ Allow the filter contents to drain (wait approx. 2 – 3 minutes).
- ▶ As a safety precaution, place a cleaning cloth below the filter module.

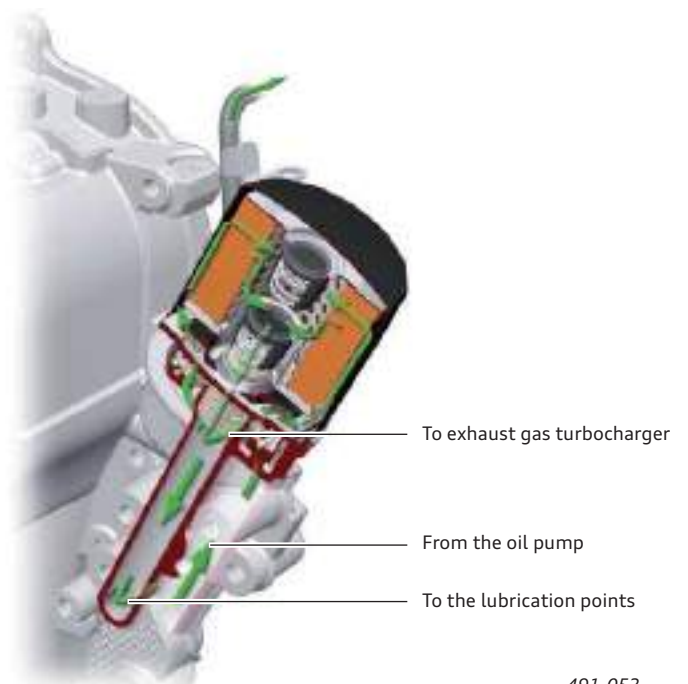

491_052

Air supply

System overview

The 1.4l 136kW TFSI engine employs a Roots blower combined with an exhaust gas turbocharger. This means that, depending on torque requirements, the engine is charged not only by the exhaust gas turbocharger but also by a mechanical Roots blower.

Fresh air is drawn in through the air filter. The position of the control flap in the control flap control unit determines whether the fresh air flows through the Roots blower and/or directly to the exhaust gas turbocharger.

The fresh air from the exhaust gas turbocharger flows into the intake manifold via the charge air cooler and the throttle valve control unit.

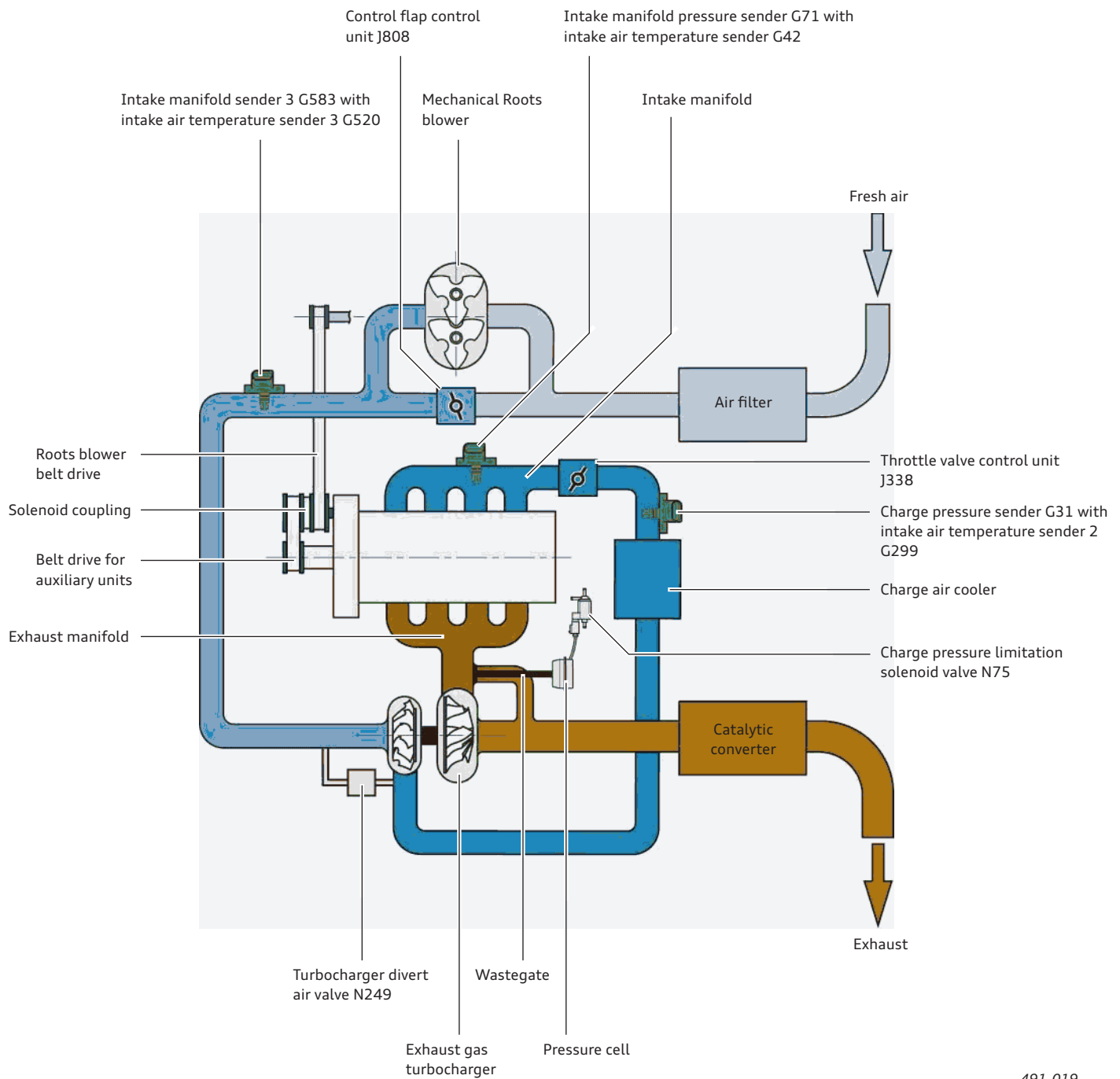

491_019

Operating ranges of the twin charging system

The diagram shows the operating ranges of the mechanical Roots blower and the exhaust gas turbocharger.

Depending on torque requirements, the engine control unit decides whether and, if so, how the required charge pressure is to be produced.

The exhaust gas turbocharger operates throughout the ranges shown in red. As can be seen, the energy of the exhaust gas at low engine speeds alone is not enough to produce the required charge pressure. The grey regions show the operating range of the Roots blower.

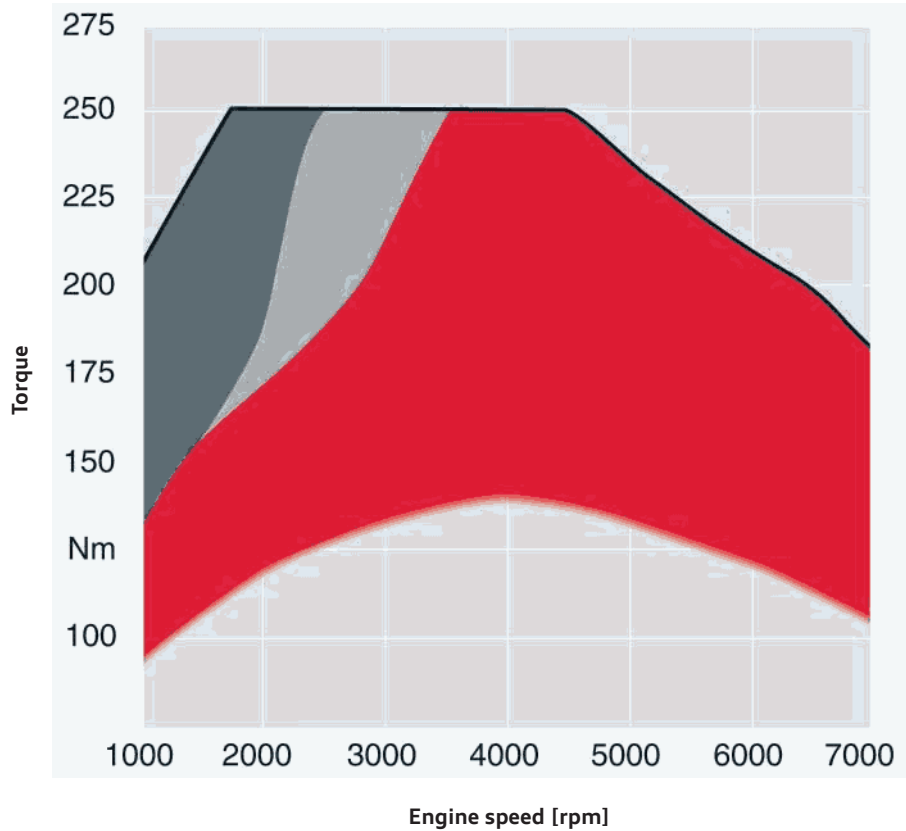

491_018

Continuous charging range of the Roots blower

The Roots blower is continuously activated from the minimum required torque to an engine speed of 2400 rpm.

The charge pressure of the Roots blower is regulated by the control flap control unit.

Demand-dependent charging range of the Roots blower

The Roots blower is activated in response to demand up to a maximum speed of 3500 rpm. This is necessary, for example, if the vehicle is driven at constant speed within this range and then accelerated rapidly.

Due to the inertia of the turbocharger, this would result in delayed acceleration (turbo lag). For this reason, the Roots blower is activated, so that the required charging pressure is attained as quickly as possible.

Charging range of exhaust gas turbocharger alone

In the red region, the exhaust gas turbocharger alone is able to generate the required charge pressure.

Charge pressure is regulated by the charge pressure limitation solenoid valve N75.

Implementation of operating ranges

Depending on engine load and speed range, the engine control unit calculates how the fresh air needed to generate the required torque flows into the cylinders.

At the same time the engine control unit decides whether the exhaust gas turbocharger alone can generate the charge pressure or the Roots blower has to be activated.

Naturally aspirated operation at low engine load

In naturally aspirated mode, the control flaps is fully open. The intake fresh air flows to the exhaust gas turbocharger via the control flap control unit J808. Although the exhaust gas turbocharger is driven by the exhaust gases, the energy of the exhaust gases is so low, only a small charge pressure is produced. The throttle valve is opened according to the driver input and a vacuum occurs inside the intake manifold.

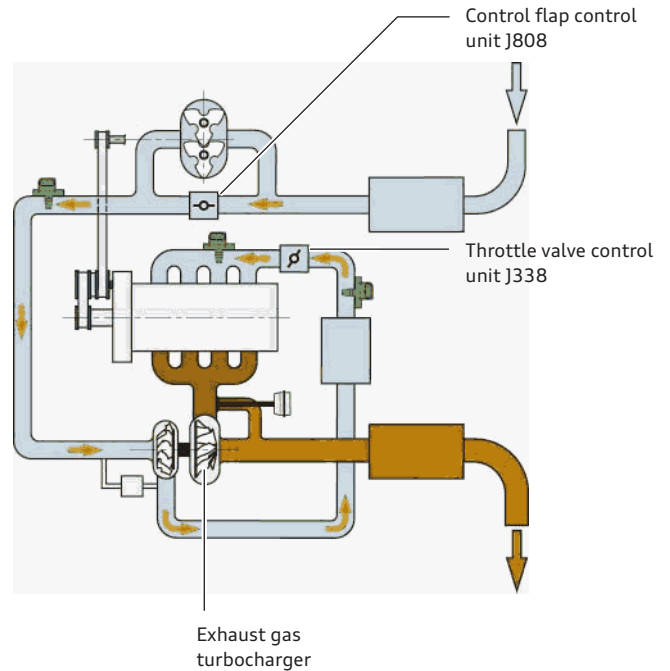

491_020

Roots blower and exhaust gas turbocharger operation at high engine load and engine speeds of up to 2400 rpm

In this range, the control flap is closed or partially opened to regulate the charge pressure. The Roots blower is activated by a solenoid coupling and driven by the Roots blower belt drive. The Roots blower induces the air and compresses it. The compressed fresh air is pumped to the exhaust gas turbocharger by the Roots blower. Here the compressed air is compressed still further. The charge pressure of the Roots blower is measured by the intake manifold pressure sender G583 and regulated by the control flap control unit J808. The total charge pressure is measured by the charge pressure sender G31. The throttle valve is fully open. A pressure of up to 2.5 bar (absolute) is present inside the intake manifold.

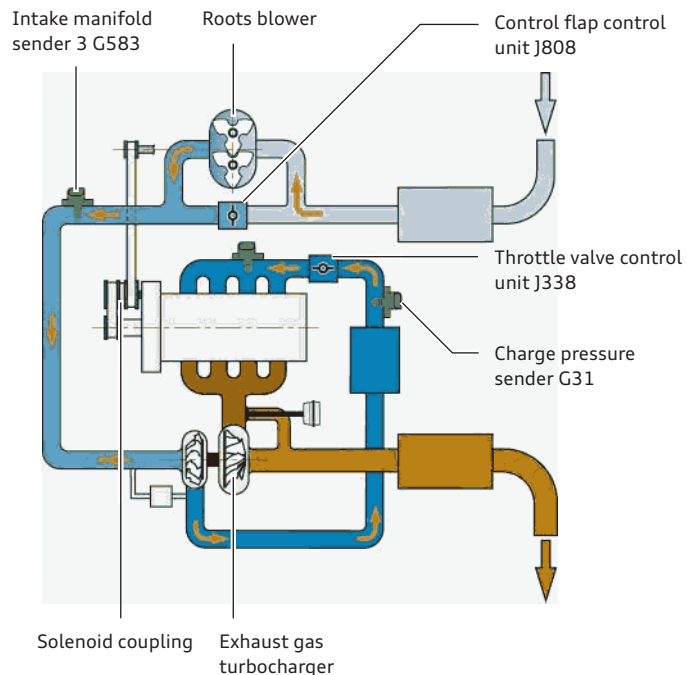

491_021

Exhaust gas turbocharger and Roots blower operation at high engine load and engine speeds of between 2400 and 3500 rpm

In this range, for example, the charge pressure is generated solely by the exhaust gas turbocharger when the vehicle is travelling at a constant speed. If the vehicle now accelerates rapidly, the exhaust gas turbocharger would be too sluggish to build up the charge pressure quickly. Turbo lag would occur.

To prevent this from happening, the engine control unit activates the Roots blower briefly and regulates the control flap control unit J808 according to the required charge pressure. This helps the exhaust gas turbocharger to produce the required charge pressure.

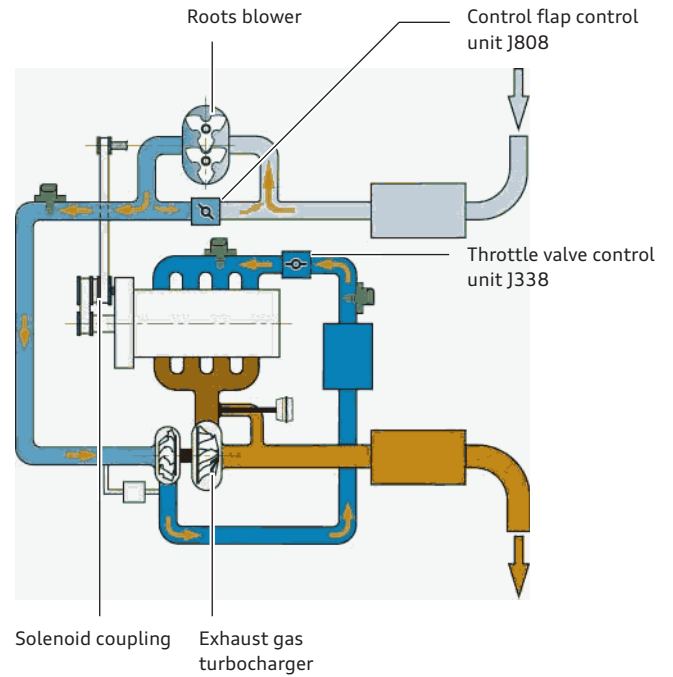

491_022

Exhaust gas turbocharger operation

Upwards of an engine speed of approx. 3500 rpm, the exhaust gas turbocharger alone can generate the required charge pressure at any operating point.

The control flap is fully open and the fresh air flows directly to the exhaust gas turbocharger. In all conditions, the exhaust gas now has enough energy for the required charge pressure to be produced by means of the exhaust gas turbocharger.

The throttle valve is fully open. A pressure of up to 2.0 bar (absolute) is present inside the intake manifold.

The charge pressure of the exhaust gas turbocharger is measured by the charge pressure sender G31 and regulated by the charge pressure limitation solenoid valve N75.

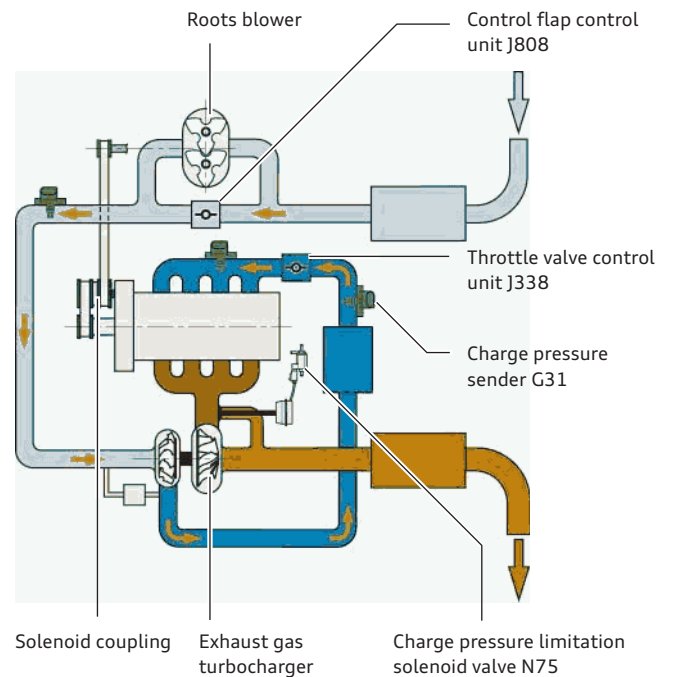

491_023

Twin charging with Roots blower and exhaust gas turbocharger

Roots blower

The Roots blower is a mechanical turbocharger and can be activated by means of a solenoid coupling.

Advantages:

- ▶ Quick charge pressure build-up
- ▶ High torque at low engine speeds
- ▶ Activated on demand only
- ▶ No external lubrication and cooling required

Drawbacks:

- ▶ Uses up engine power
- ▶ Charge pressure is generated depending on engine speed and then regulated, with the result that some of the generated energy is again lost



Mechanical Roots blower

Exhaust gas turbocharger

The exhaust gas turbocharger is permanently exhaust driven.

Advantages:

- ▶ Very high efficiency through the use of exhaust gas energy

Drawbacks:

- ▶ In a small engine, the charge pressure generated at low engine speeds may not be enough to produce high torque.
- ▶ High thermal load



Exhaust gas turbocharger

Components of the exhaust turbocharging system

Exhaust gas turbocharger module

Together, the exhaust gas turbocharger and the exhaust manifold form a module.

On account of the high exhaust temperatures, both components are made of heat-resistant cast steel.

To protect the shaft bearing assembly against excessively high temperatures, the exhaust gas turbocharger is integrated in the cooling circuit. A circulation pump runs on for up to 15 minutes after the engine is shut off to ensure that the exhaust gas turbocharger does not overheat. This prevents vapour bubble formation in the cooling system. The shaft bearing assembly is connected to the oil circuit for lubrication purposes.

The electrical turbocharger divert air valve N249 and a pressure cell for charge pressure limitation via the wastegate are still located adjacent to the exhaust gas turbocharger module.

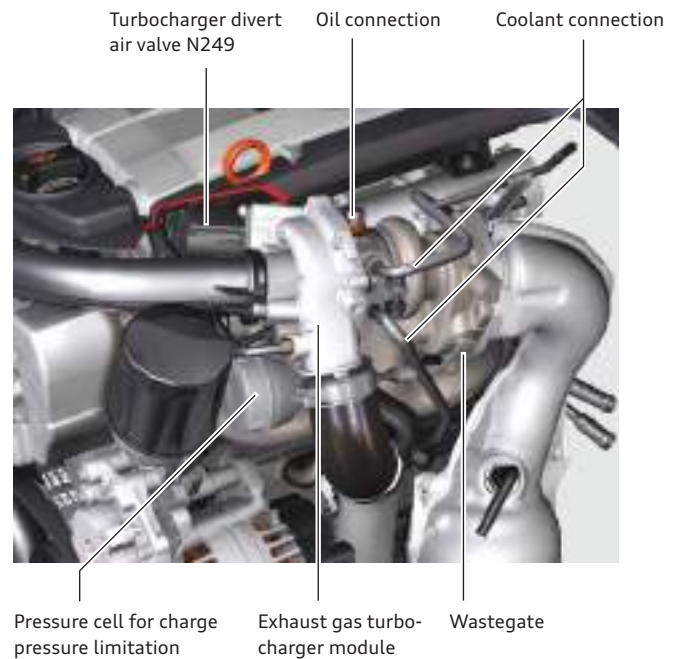

491_032

Exhaust manifold

In petrol engines, the air-fuel mixture was previously enriched early due to the high exhaust gas temperatures.

The exhaust manifold of the 1.4l 136kW TFSI engine is designed for exhaust temperatures of up to 1050 °C. This allows the engine to be operated at a high charge pressure and lambda 1 in almost all mapped operating ranges.

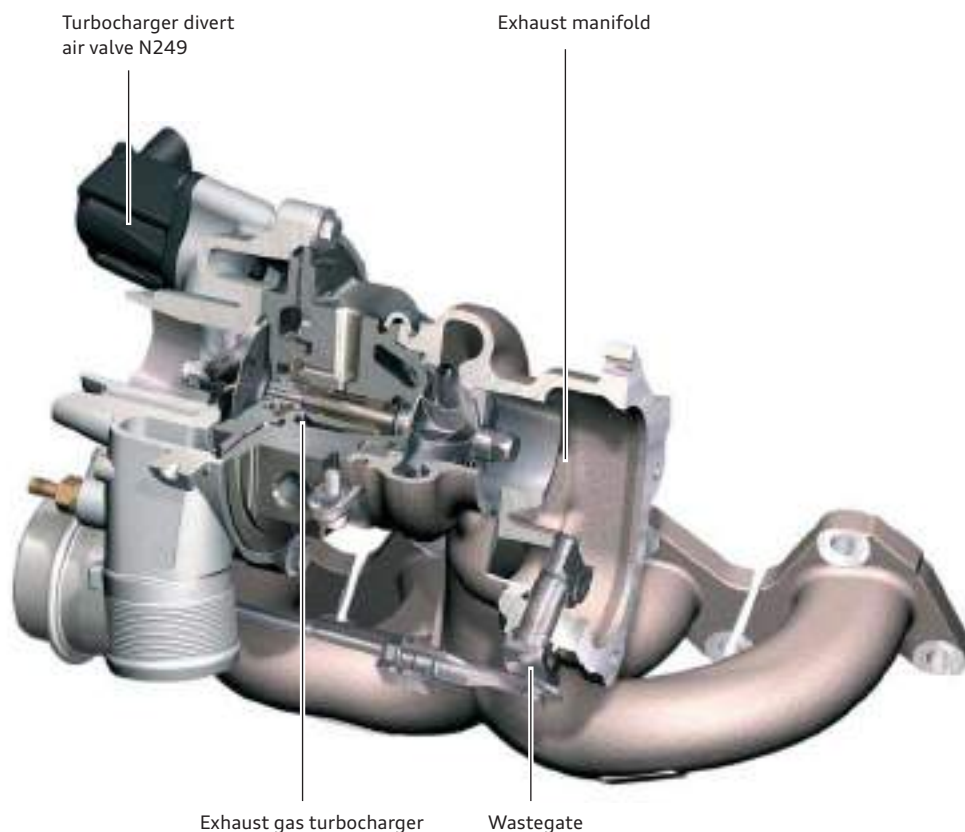

491_033

Roots blower

Mechanical Roots blower

The mechanical Roots blower is bolted onto the cylinder block downstream of the air filter on the intake manifold side. The Roots blower is also known as a screw compressor due to the shape of its two rotors. Unlike in the 3.0l V6 TFSI engine, the rotors do not have three vanes, rather four.

Charge pressure is regulated by a control flap control unit. The maximum charge pressure which the Roots blower can generate is 1.75 bar (absolute).

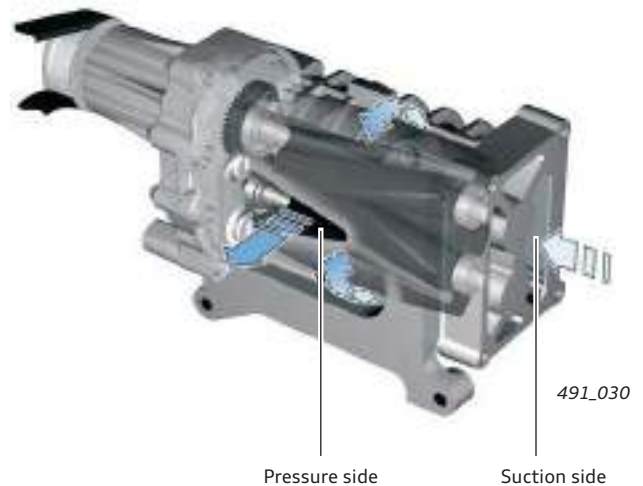
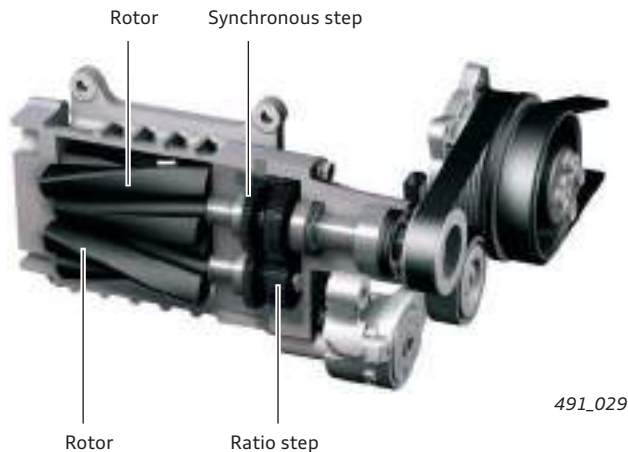

Drive

The Roots blower is activated when required and driven by the coolant pump via an auxiliary drive. The auxiliary drive is activated by a maintenance-free solenoid coupling on the coolant pump module. If the solenoid coupling is deactivated, three lead springs pull the friction plate back into the initial position. Due to the high forces involved, "clicking" of the solenoid coupling is normal. This can occur at engine speeds of up to 3400 rpm.

Due to the ratios from the crankshaft pulley to the Roots blower pulley, as well as the internal ratio of the Roots blower, the Roots blower rotates at five times the speed of the crankshaft. The maximum speed of the Roots blower is 17,500 rpm.

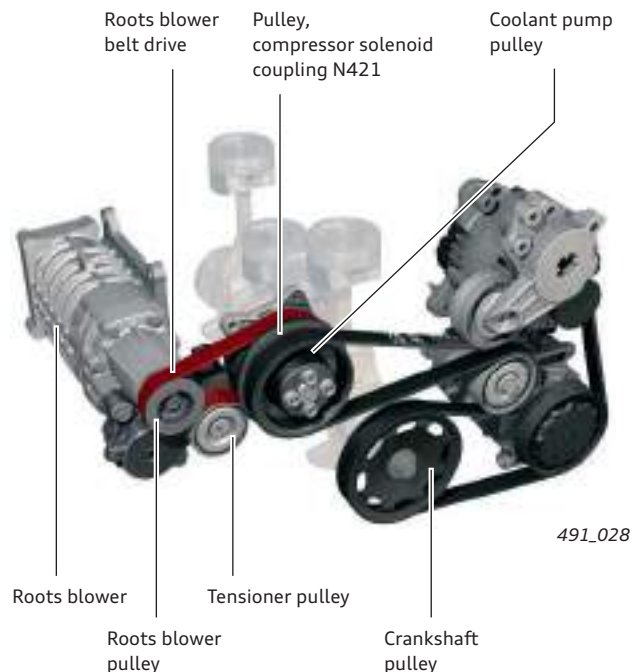

Reference

For further information about the design of Roots blowers, refer to Self Study Programme 437 "Audi 3.0l V6 TFSI Engine with Roots Blower".

Solenoid coupling

In addition to its typical function of delivering coolant, the coolant pump has an integrated solenoid coupling for activating the mechanical Roots blower.

The coolant pump, alternator and AC compressor are driven by the six-groove primary pulley. The five-groove poly V-belt of the secondary pulley drives the air compressor of the coolant pump.

The compressor solenoid coupling N421 establishes a frictional connection with the Roots blower drive. The pulley of the coolant pump is bolted to the drive shaft of the coolant pump. The pulley for driving the Roots blower rotates on the ball bearings. The solenoid coil is firmly connected to the coolant pump housing.

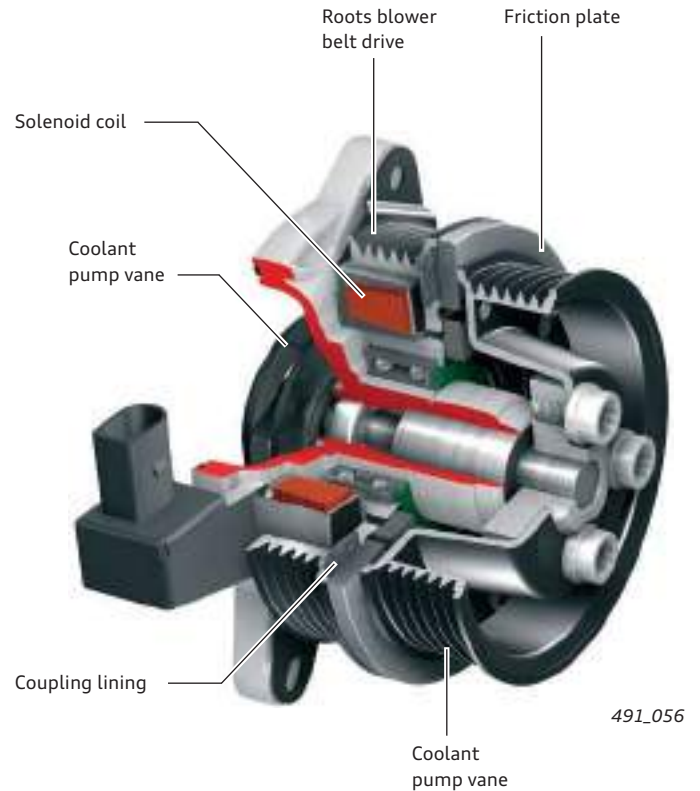

Compressor solenoid coupling not actuated

The electrical circuit of the solenoid coil is not closed. As a result, a frictional connection is not established (air gap A) due to the spring force between the friction plate and friction lining. The stationary pulley runs freely on the ball bearings.

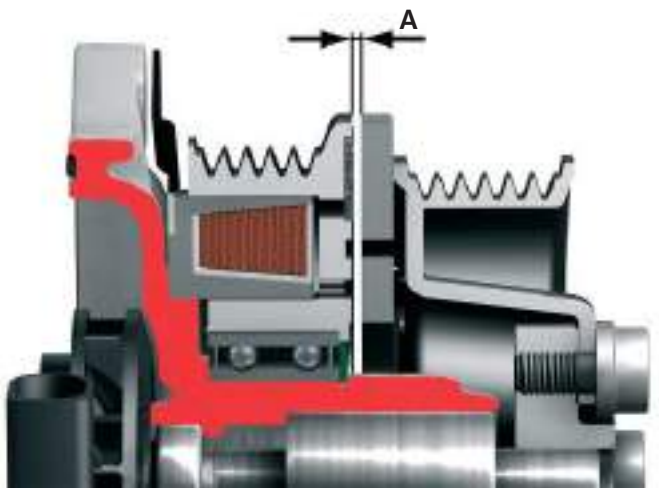

Compressor solenoid coupling actuated

The electrical circuit of the solenoid coupling is closed by the engine control unit. The magnetic force pulls the friction plate against the coupling lining. The coolant pump pulley is now frictionally connected to the Roots blower pulley.

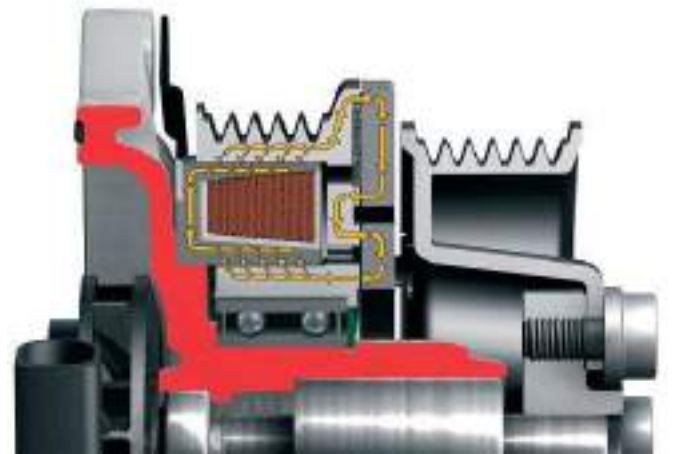

Comfortable starting of the compressor

To ensure that the compressor solenoid coupling operates smoothly, the electrical current characteristic is evaluated while the solenoid coupling is being activated.

For this purpose, a corresponding sensor installed in the engine control unit. The measured value is compared to a characteristic map, and a wear value is assigned to the coupling. To ensure soft and comfortable starting, the activation pulse (PWM signal) is adapted by the engine control unit according to wear.

Adapted values are stored in the control unit. If the coolant pump is replaced, this adapted value must be reset. For this purpose, there is a corresponding test routine in the Guided Fault Finding which is indicated in the Workshop Manual "Engine Mechanicals".

Function

Both Roots blower rotors are designed in such a way that the volume on the suction side increases when they rotate. In this way, the fresh air is sucked in and delivered from the rotors to the pressure side of the Roots blower.

The volume between the two Roots blowers decreases on the pressure side. The air is forced towards the exhaust gas turbocharger.

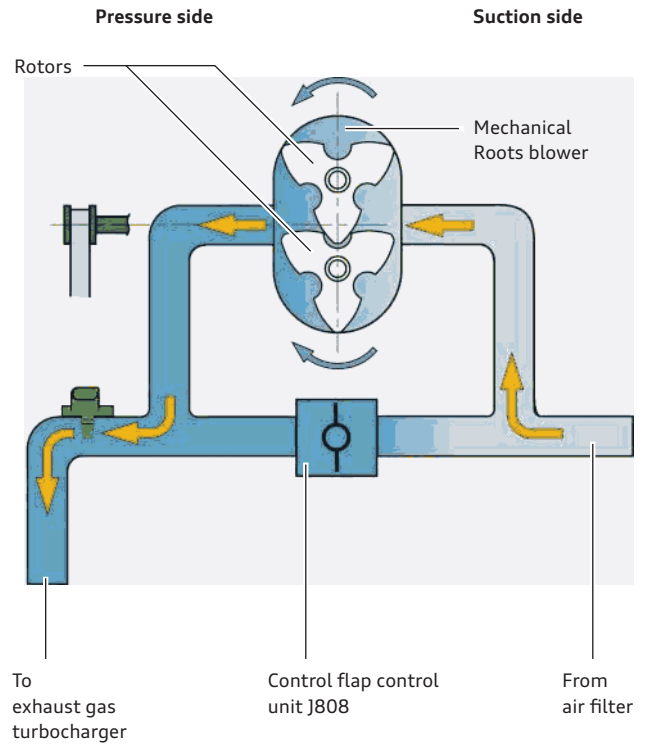

491_024

Charge pressure control

The charge pressure is regulated by the position of the control flap. If the control flap is closed, the Roots blower produces the maximum charge pressure at this speed. The compressed fresh air is pumped towards the exhaust gas turbocharger. If the charge pressure is too high, the control flap is opened slightly. A portion of the fresh air now flows towards the exhaust gas turbocharger and the remainder through the partially open control flap towards the suction side of the Roots blower. The charge pressure drops. The air is again sucked in and compressed on the suction side. This reduces the load on the Roots blower, and the amount of power required to drive the Roots blower decreases. Charge pressure is measured by the intake manifold pressure sender 3 G583.

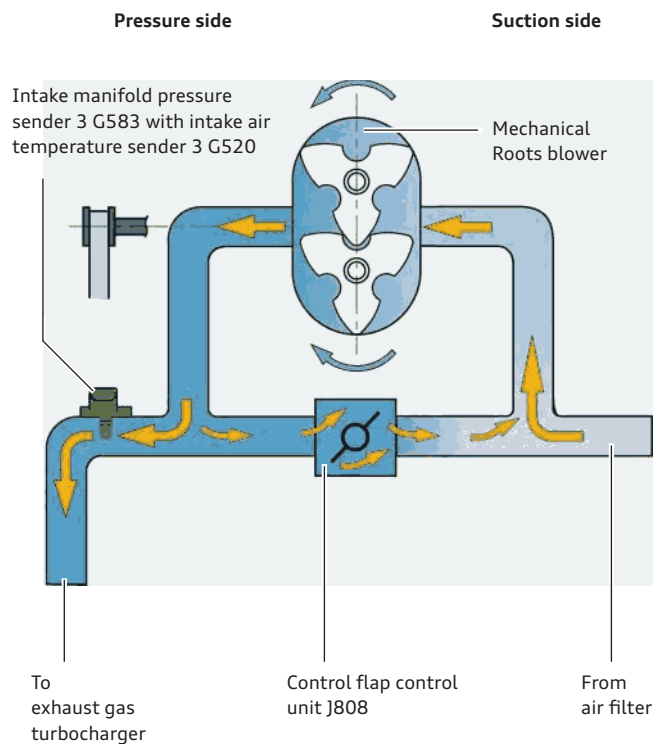

491_025

Air ducting/charge air cooling system on the Roots blower

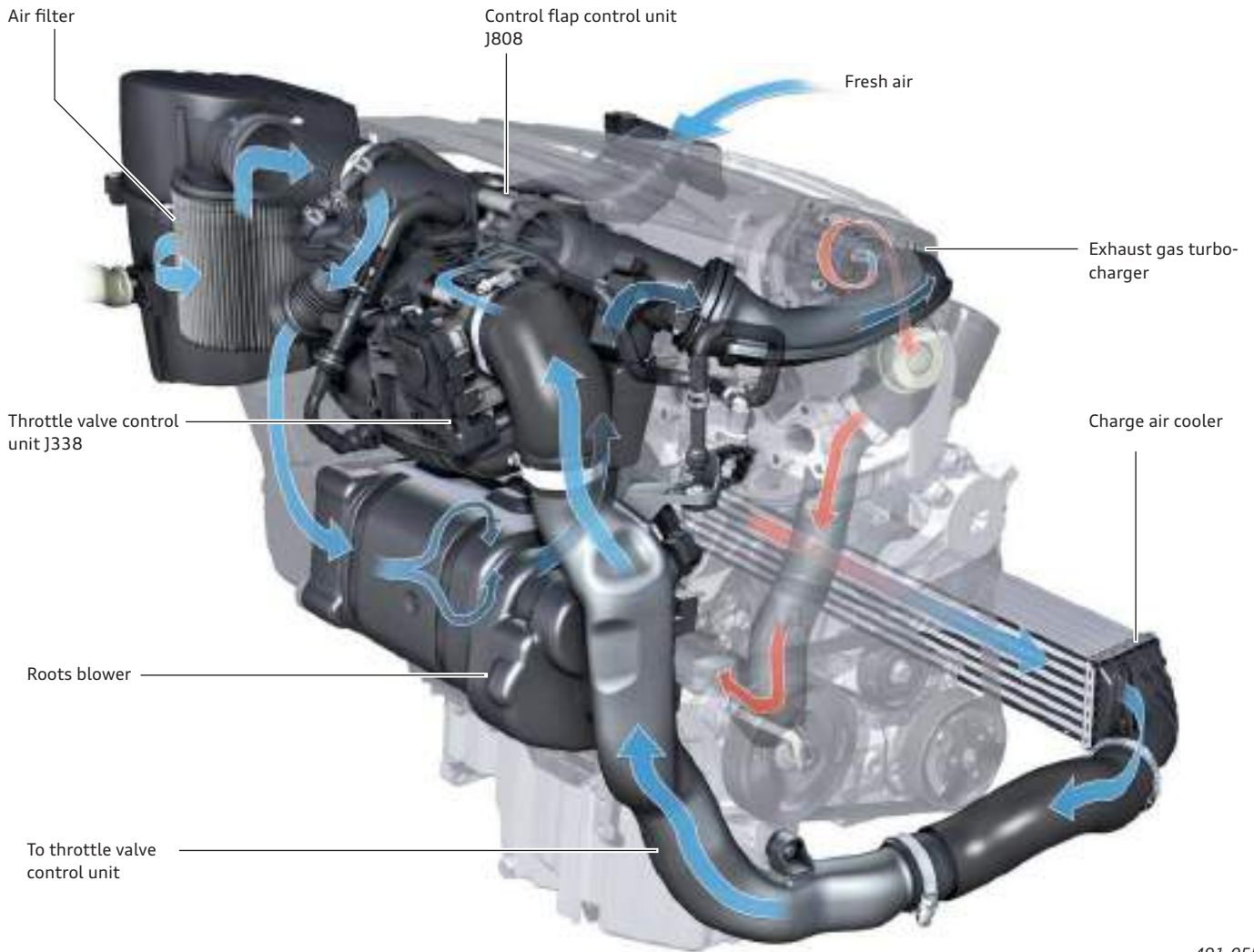

491_055

Charge pressures at full throttle

The diagram shows the charge pressures of the charging system components at full throttle. The charge pressure from the exhaust gas turbocharger rises with increasing engine speed, allowing the output of the Roots blower to be reduced. As a result of this, the Roots blower requires less engine power.

The Roots blower produces a high volume of air even at low engine speeds, resulting in a high exhaust mass flow, which is admitted to the exhaust turbocharger turbine.

The Roots blower is, therefore, able to produce the required charge pressure at lower engine speeds than a purely turbocharged engine. The turbocharger is, in principle, by "jump-started" by the Roots blower.

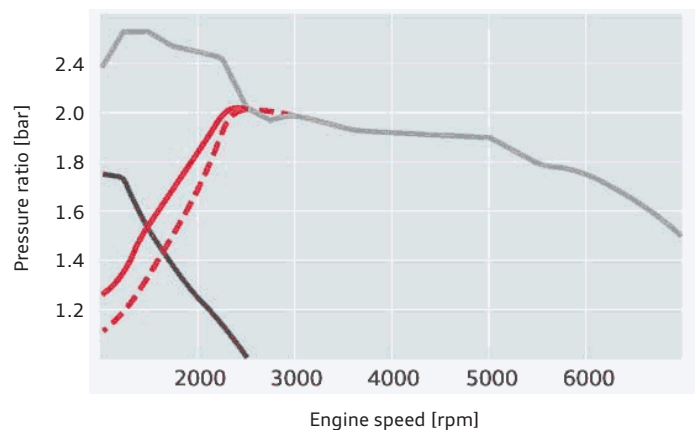

- Charging pressure of the Roots blower
- Charge pressure of the exhaust turbocharger
- Charge pressure of the exhaust turbocharger and the Roots blower together
- - - Charge pressure of the exhaust turbocharger for an engine with turbocharging only

491_048

Sensors and actuators

Intake manifold pressure sender G71 with intake air temperature sender G42

This sender measures the pressure and temperature in the intake manifold. The intake air mass is calculated from the signals generated by the sensor and the engine speed.

If the signal fails, the throttle valve position and the temperature of the G299 is used as a substitute signal. The turbocharger is operated under open-loop control only. If additional sensors fail, the Roots blower may shut down.



491_059

Intake manifold pressure sender 3 G583 with intake air temperature sender 3 G520

This sender measures the pressure and temperature of the intake air in the section after the control flap control unit J808 and the Roots blower. The signal is used to control the charge pressure produced by the Roots blower and to protect components against excessively high temperatures. At temperatures upwards of 130 °C, Roots blower power output is reduced.

If this sender fails, the charge pressure cannot be regulated. Operation using only a Roots blower is not permitted. The exhaust gas turbocharger is operated under open-loop control only, i.e. low engine output at low engine speeds.



491_060

Charge pressure sender G31 with intake air temperature sender 2 G299

This sender measures the pressure and temperature in the section shortly before the throttle valve control unit. It provides the pressure signal for controlling the charge pressure produced by the exhaust turbocharger, as well as the temperature signal for calculating the charge pressure correction value (change of temperature = change of air density).

If this sender fails, the exhaust gas turbocharger can only be operated under open-loop control. If additional sensors fail, the Roots blower shuts down.



491_061

Ambient pressure sensor in engine control unit J623

This sender measures the ambient pressure. This serves as an altitude-dependent correction value.

If this sender fails, the exhaust gas turbocharger can only be operated under open-loop control. This would result in higher emissions and loss of power.

Engine control unit J623 with ambient pressure sender



491_047

Control flap control unit J808 with control flap potentiometer G584

The control flap potentiometer G584 recognises the position of the control flap. The engine control unit can then set any desired position of the control flap.

In case of signal failure, the control flap remains permanently open. The Roots blower is no longer activated.



491_062

Noise insulation

Due to the alignment of the Roots blower toward the occupant cell, some residual noise can be heard directly by the occupants. The Roots blower may produce a "howling" sound under heavy acceleration at engine speeds of 2000 – 3000 rpm. This is the normal turbine-like operating noise of a Roots blower.

To reduce the noise level, several measures have been taken.

To keep the mechanical noise of the Roots blower to a minimum:

- ▶ the gearing has been adapted, e.g. meshing angle and torsional backlash
- ▶ the shafts of the Roots blower have been stiffened
- ▶ the housing of the Roots blower is specially ribbed for added strength.

To reduce noise during intake and compression:

- ▶ silencers have been fitted at both ends (suction and pressure sides) of the Roots blower
- ▶ the Roots blower is encapsulated and the shells are additionally lined with absorptive foam.

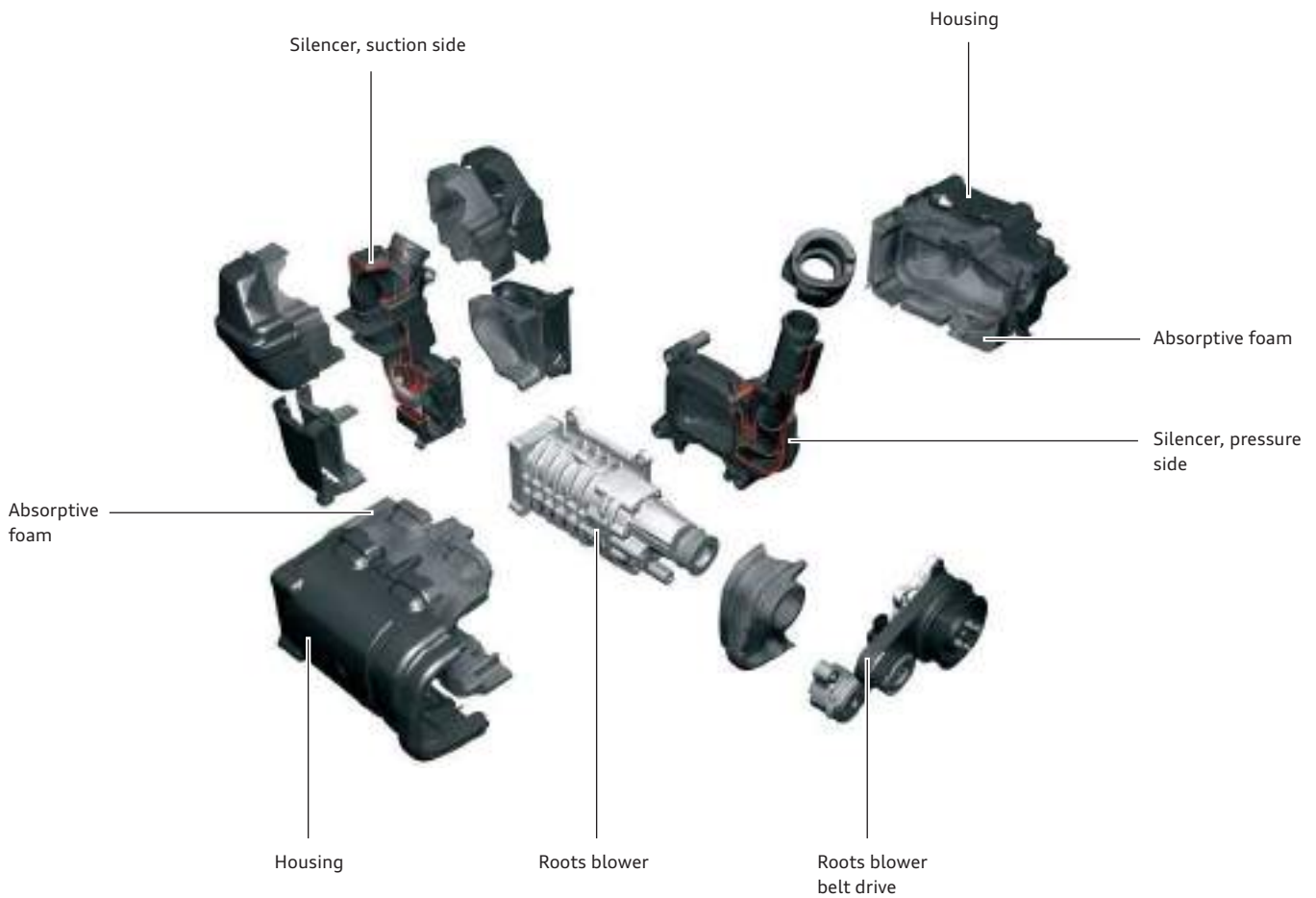

491_031



Note

The Roots blower must not be opened.

The chamber containing the reduction and synchro gears is filled with oil. This is a lifetime filling.

Charge air cooling

The 1.4l 136kW TFSI engine employs an air-to-air charge air cooling system.

This means that the charge air flows through a cooler, where it dissipates its heat to the aluminium fins. The fins, in turn, are cooled by the ambient air.

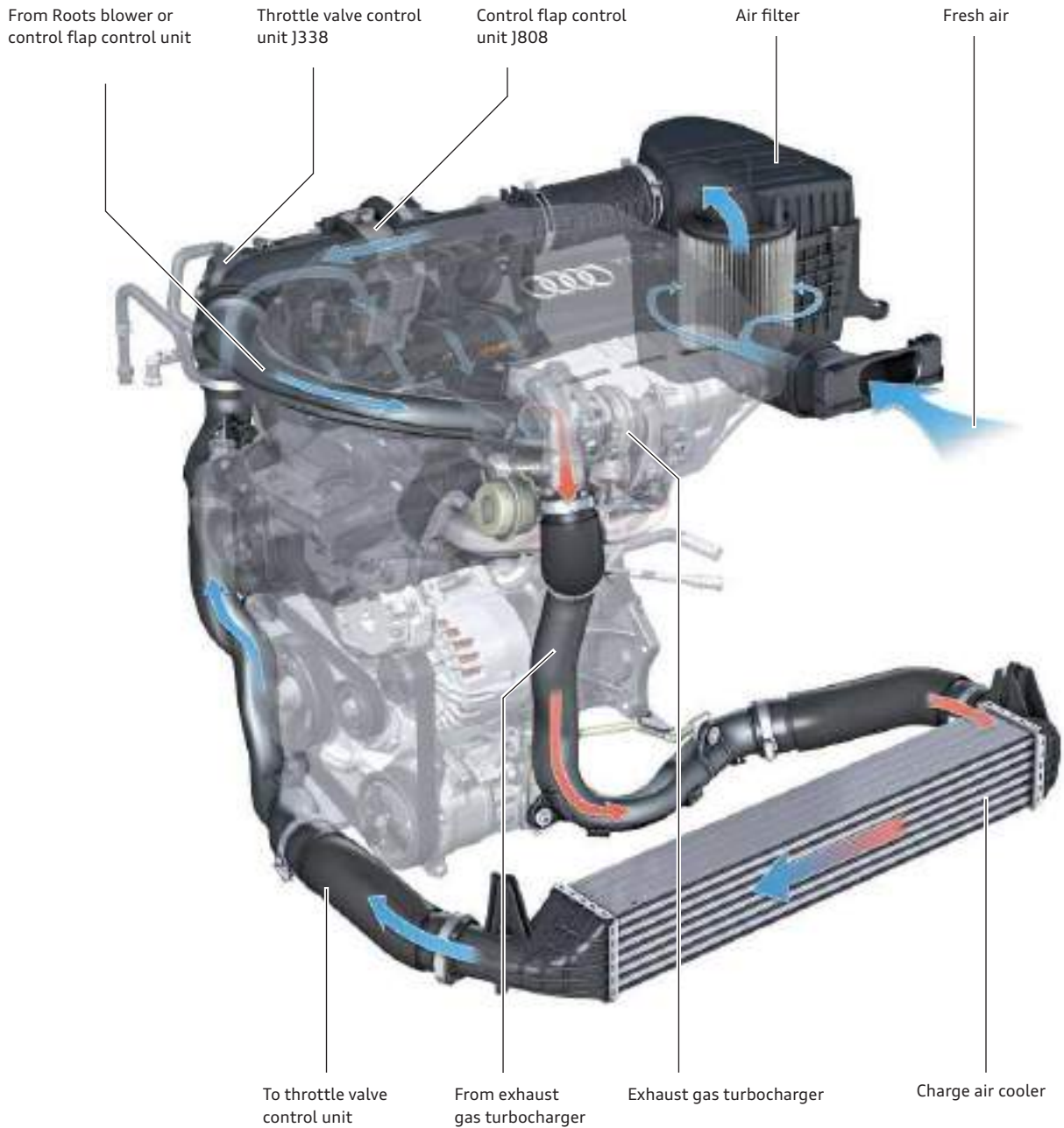

491_034

After the intake air has passed the exhaust gas turbocharger, it is very warm: it is heated up to temperatures as high as 200 °C. This is due mainly to the compression process, but also to the very hot exhaust gas turbocharger.

As a result, the air has a lower density, and less oxygen enters the cylinders.

Cooling the intake air to slightly above ambient temperature increases its density and allows more oxygen into the cylinders. Other benefits of this cooling process are reduced tendency to knock and nitrous oxide emissions.

Exhaust system

Overview

The exhaust gases are treated by a three-way catalytic converter of ceramic construction. To enable the catalytic converter to heat up quickly despite the heat loss due to the exhaust gas turbocharger, the connecting tube between the exhaust gas turbocharger and the catalytic converter is air-gap insulated.

The oxygen sensor before the catalytic converter is a linear oxygen sensor. It is integrated in the inlet of the closed-coupled three-way catalytic converter. This layout ensures that the exhaust gases from all cylinders flow evenly into the catalytic converter, while also ensuring that the lambda control system starts quickly.

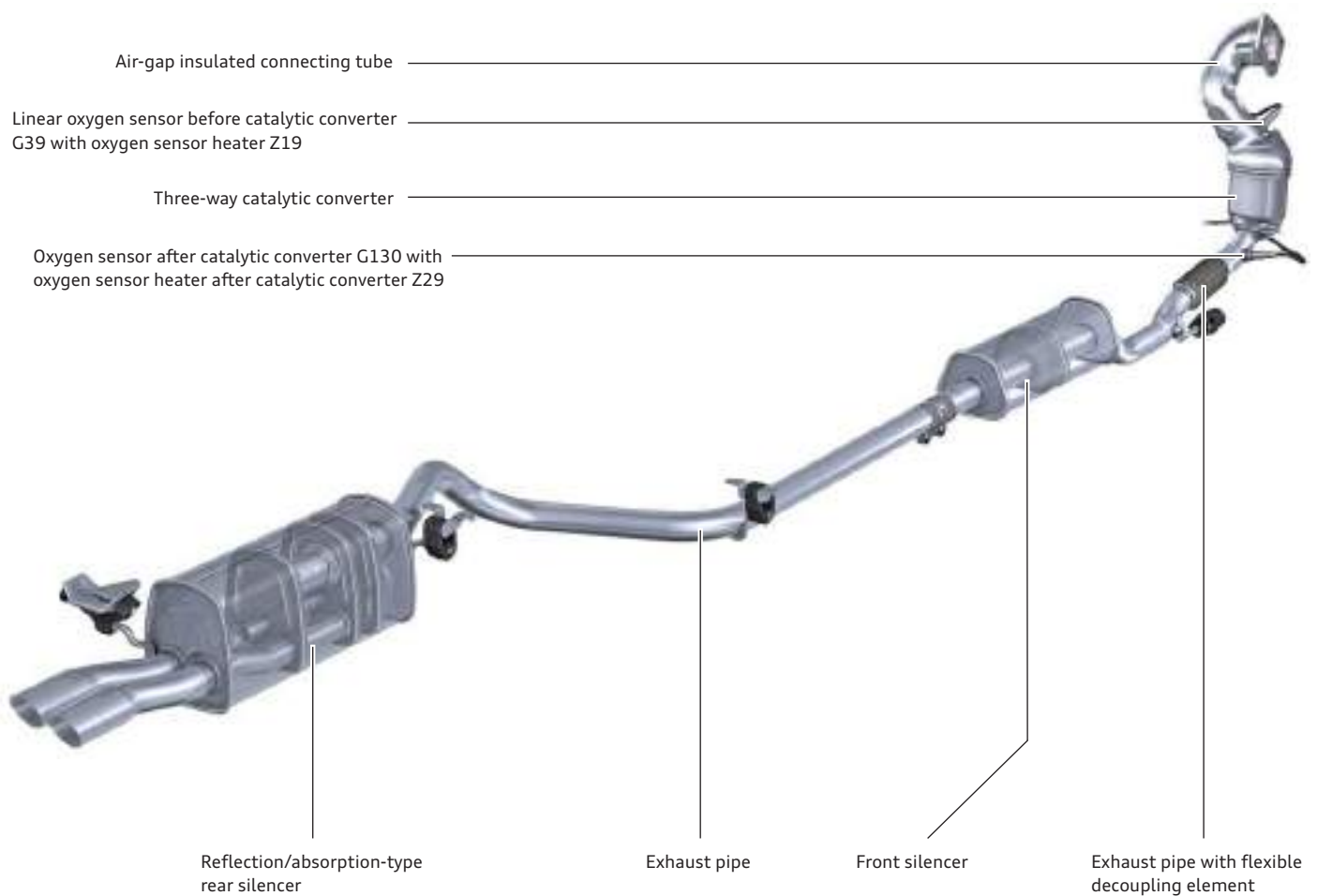

491_009



Note

Faults relevant to exhaust emissions are indicated by the exhaust warning light K83 and functional faults in the system by the electronic power control fault lamp K132.

Dual-circuit cooling system

Overview

The 1.4l 136kW TFSI engine has two independent cooling systems:

- ▶ charge air cooling system (see page 25)
- ▶ engine cooling system.

The cooling system in the engine is divided into two circuits. Approximately one third of the coolant in the engine flows to the cylinders and two thirds to the combustion chambers in the cylinder head.

Inside the cylinder head, the coolant is directed to the inlet and outlet ends. A uniform temperature level is thus achieved inside the cylinder head. The cooling system has a cross-flow configuration.

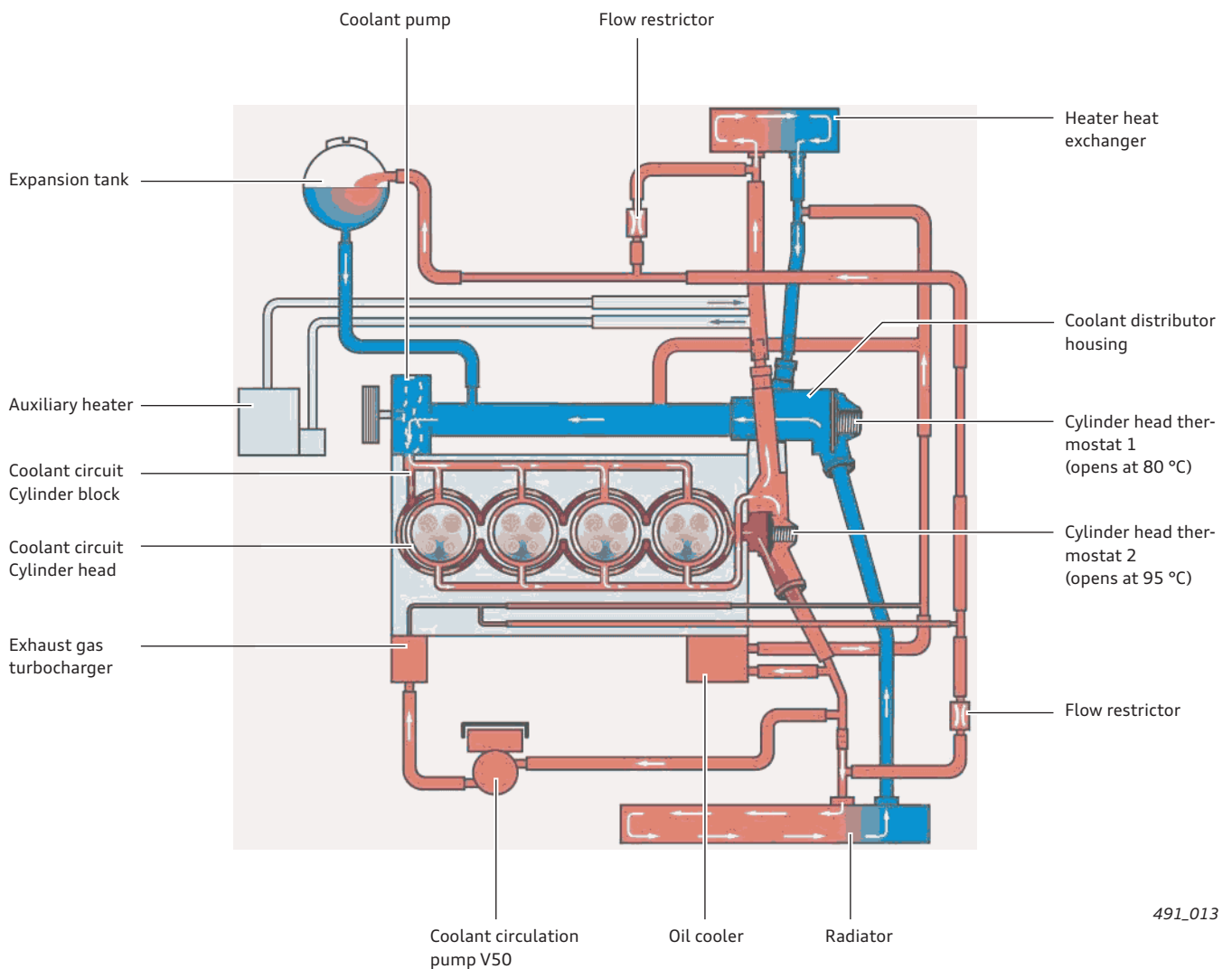

491_013

Legend:

- Coolant in the cylinder block
- Coolant in the cylinder head and in the remainder of the cooling system
- Cooled coolant



Reference

For further information about the dual-circuit cooling system, refer to Self-Study Programme 485 "Audi 1.2l TFSI Engine".

The dual-circuit cooling system has the following advantages:

- ▶ The cylinder block is heated more quickly because the coolant remains in the cylinder block until it reaches a temperature of 95 °C.
- ▶ Less friction occurs in the crank mechanism due to the higher temperature level in the cylinder block.
- ▶ The lower temperature level of 80 °C inside the cylinder head allows better cooling of the combustion chambers. This increases volumetric efficiency and reduces the tendency to knock.



491_035

Coolant distributor housing with two-stage thermostat

A high system pressure develops in the cooling system at high speeds due to the high coolant flow rate. The two-stage thermostat 1 opens at the exact temperature even under these conditions. In a single-stage thermostat, it would be necessary to open a large thermostat plate against the high pressure. Due to the counter-forces, however, the thermostat would not open until higher temperatures are reached.

In the two-stage thermostat, at first only a small thermostat plate opens when the opening temperature is reached. Due to the smaller surface area, the counter-forces are lower and the thermostat opens at the exact temperature. After travelling a certain distance, the small thermostate plate drives a larger thermostat plate, and the largest possible cross-section is opened.

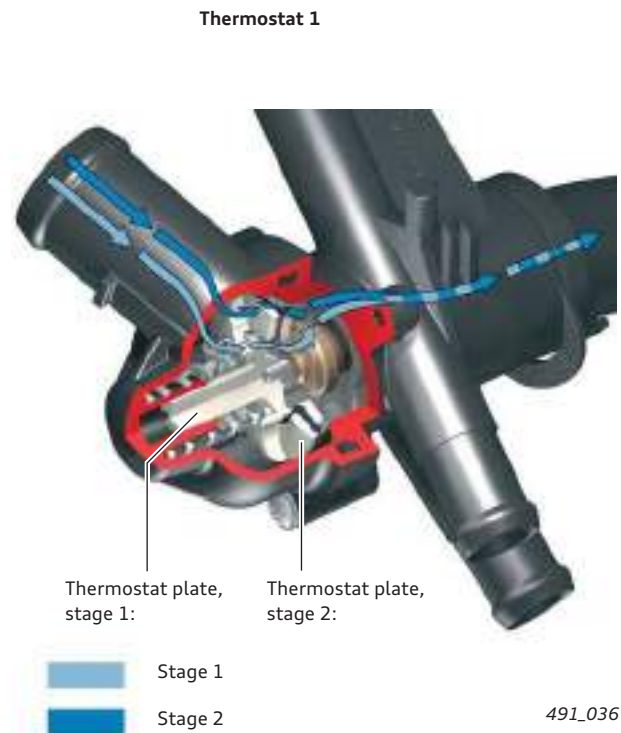

491_036

System overview

The fuel system operates in a demand responsive fashion on both the high and low pressure sides. The engine control unit regulates the fuel pump control unit J538 on the low pressure side, and thus the delivery rate of the fuel pump in the fuel tank. The fuel return pressure is adjusted to between 3 and 5 bar.

On the high pressure side, the engine control unit regulates the fuel pressure control valve N276 leading directly to the high-pressure pump. The pressures within the system are monitored by two integrated fuel pressure senders which send their signals to the engine control unit.

The central element of the fuel system is a demand responsive single-piston high-pressure pump. It is a Generation III fuel pump by Hitachi. The pump is driven by a three-lobe cam seated on the exhaust camshaft.

The system operates at pressures of between 30 and 100 bar. The pressure limiting valve installed in the pump opens at approx. 145 bar.

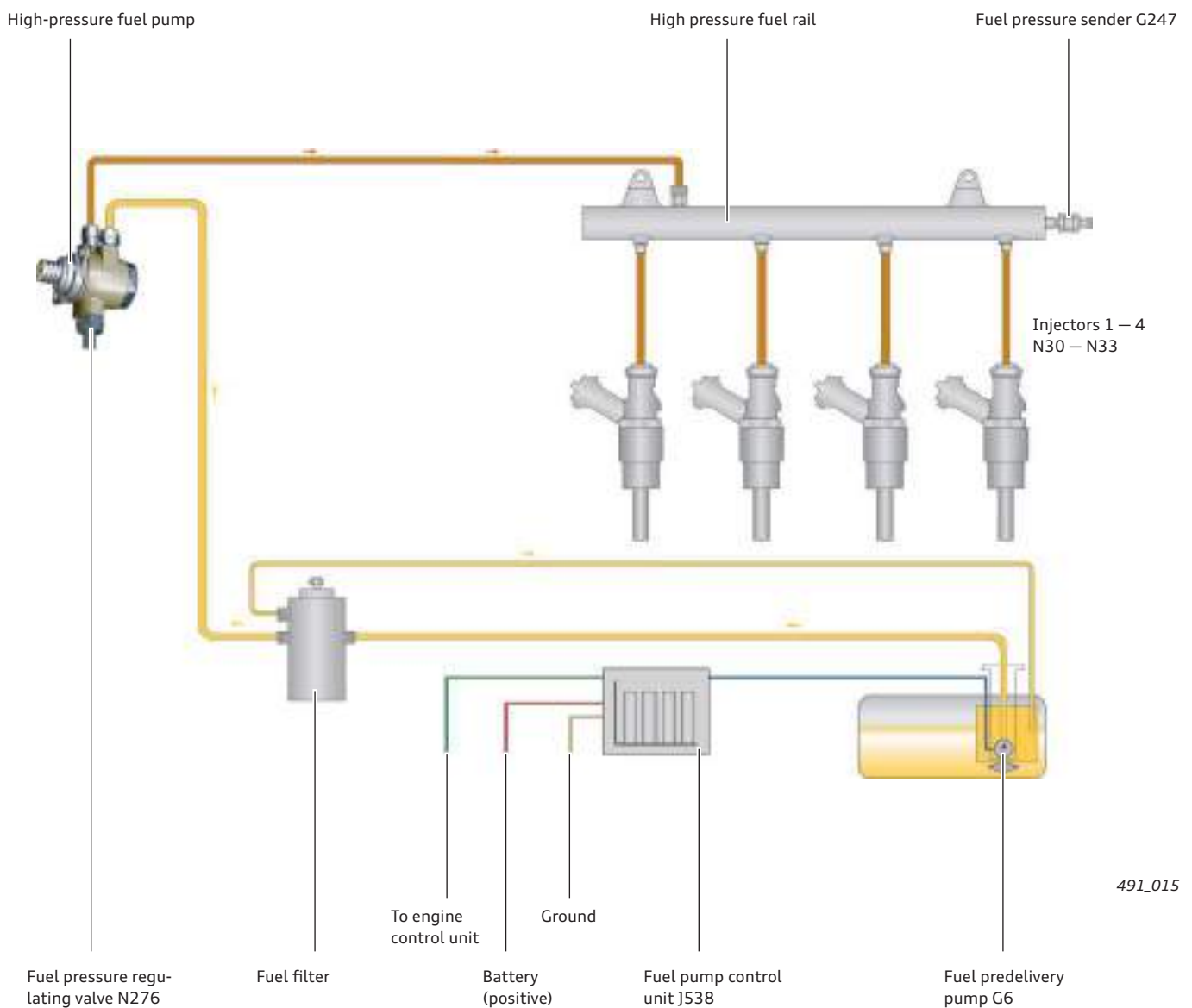

Note

Caution: injury hazard Very high pressures can occur inside the system. To open the high-pressure side, please follow the directions given in the Workshop Manual.



Reference

For a description of the operating principle and control concept of the high-pressure fuel pump, read Self Study Programme 432 "Audi 1.4l TFSI Engine".

Engine management

System overview of the 1.4l 136kW TFSI engine

Sensors

Intake manifold pressure sender G71
intake air temperature sender G42

Intake manifold sender 3 G583
Intake air temperature sender 3 G520

Charge pressure sender G31
Intake air temperature sender 2 G299

Engine speed sender G28

Hall sender G40

Throttle valve control unit J338
Throttle valve drive angle senders 1+2 for
electronic power control G187, G188

Control flap control unit J808
Control flap potentiometer G584

Accelerator pedal position sensor G79
Accelerator pedal position sensor 2 G185

Clutch position sensor G476

Brake pedal position sensor G100

Fuel pressure sender G247

Knock sensor 1 G61

Coolant temperature sender G62

Coolant temperature sender at radiator outlet G83

Oxygen sensor G39

Oxygen sensor after catalytic converter G130

Brake servo pressure sensor G294

Current measurement sensor G582

Auxiliary signals

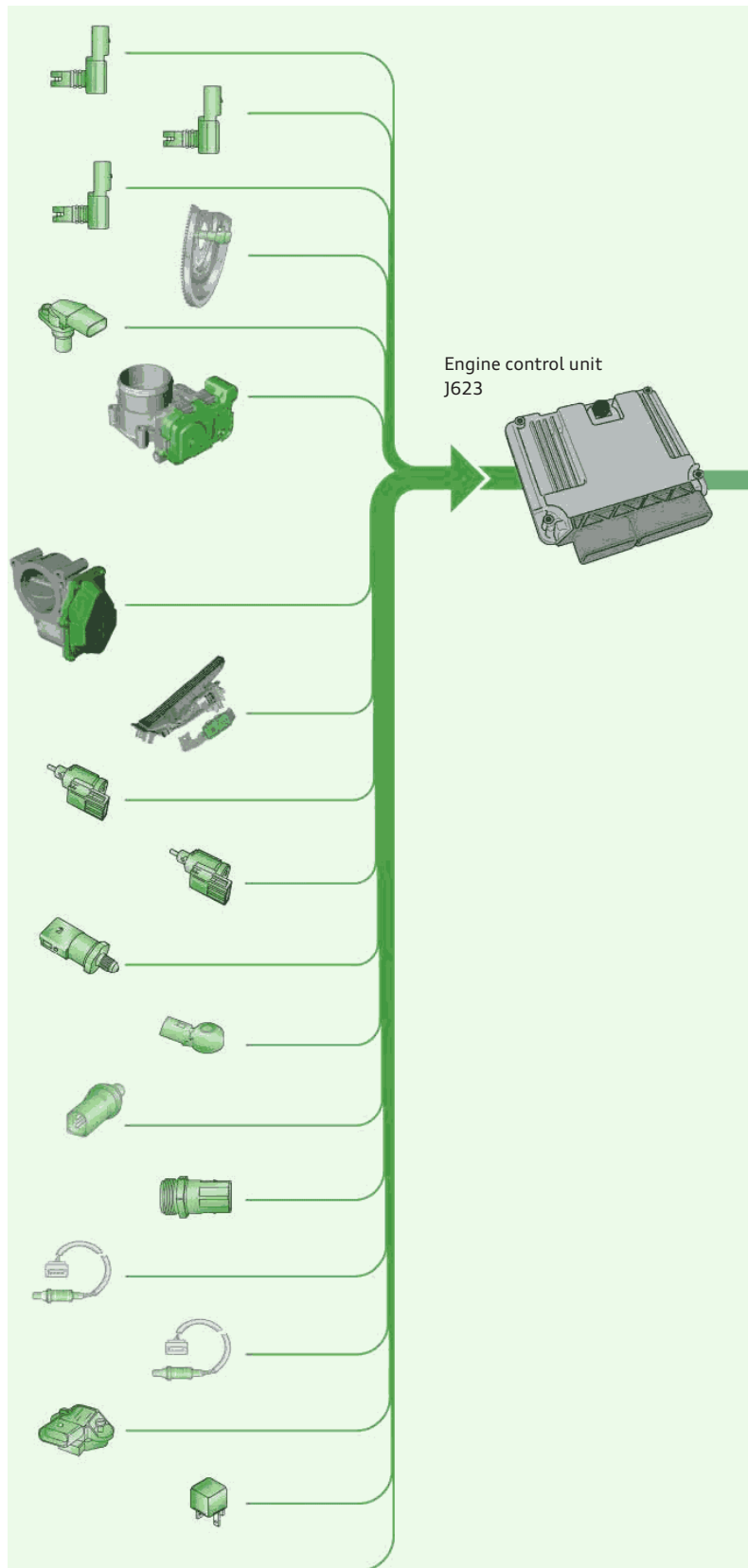

Reference

For further information about the networking of the engine control unit, refer to Self Study Programme 477 "The Audi A1".

Actuators

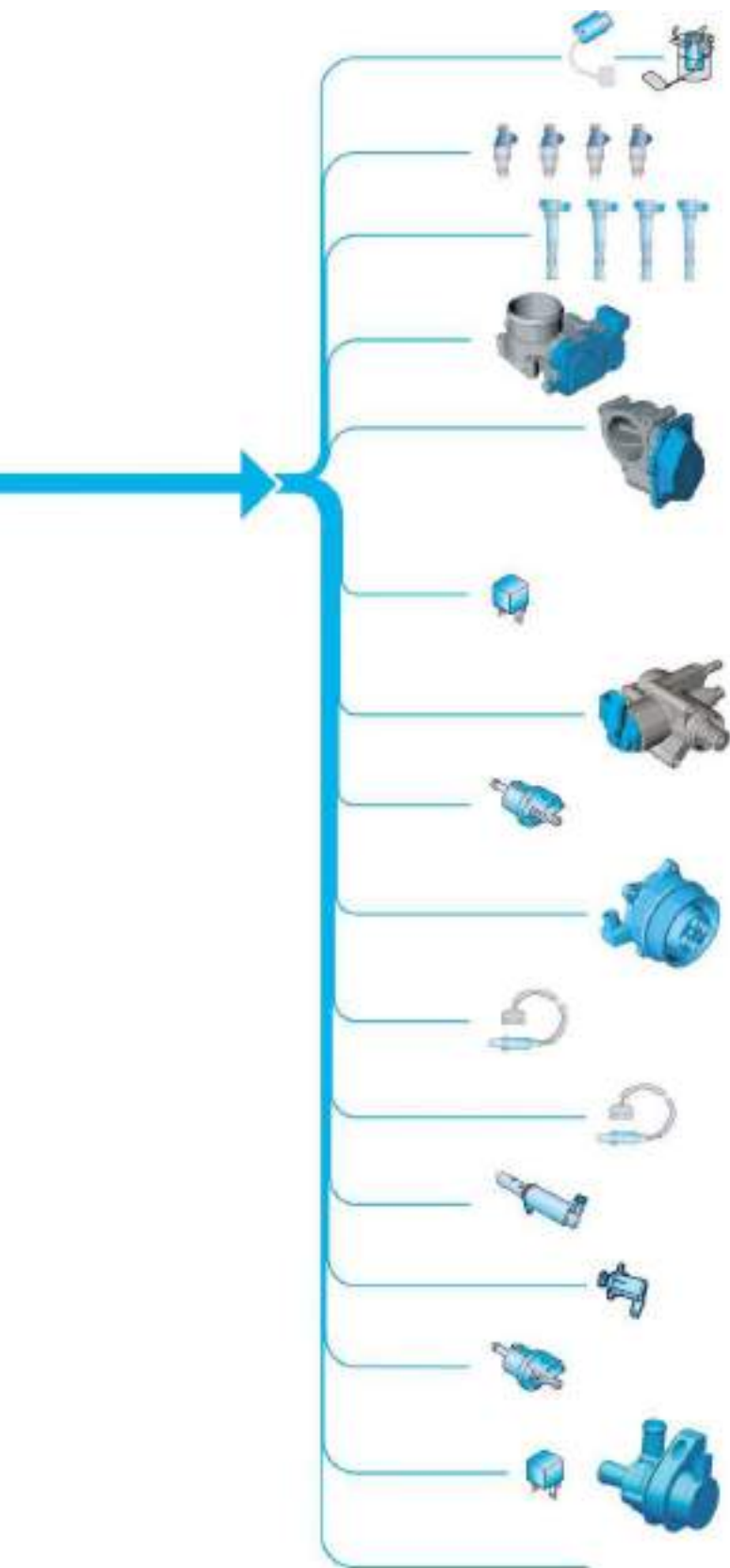

Fuel pump control unit J538
Fuel predelivery pump G6

Injectors, cylinders 1 – 4 N30 – N33

Ignition coils 1 – 4 with output stages N70, N127, N291, N292

Throttle valve control unit J338
Throttle valve drive (electronic power control) G186

Control flap control unit J808
Control flap adjustment servomotor V380

Motronic power supply relay J271

Fuel pressure regulating valve N276

Activated charcoal canister solenoid valve 1 N80

Compressor solenoid coupling N421

Oxygen sensor heater Z19

Lambda probe 1 heater, after catalytic converter Z29

Intake camshaft timing adjustment valve -1- N205

Turbocharger divert air valve N249

Charge pressure limitation solenoid valve N75

Additional coolant pump relay J496
Coolant circulation pump V50

Auxiliary signals

Sound actuator system

Introduction

This system helps to create a sporty engine note inside the occupant cell. For example, a diesel model can be made to sound like a petrol model (Audi TT with diesel engine).

On the other hand, vehicles have become increasingly better insulated, yet customers desire a rich, powerful engine sound. The first generation system is used in the Audi A1 together with the 1.4l TFSI engine with dual charging.

Components

The components of this system are integrated in the engine bulkhead or in the forward section of the exhaust system. The structure-borne sound actuator E214 produces vibrations which are transmitted into the vehicle body as structure-borne sound.

Specifications of the actuator (works on the same principle as a loudspeaker):

- ▶ Resonance frequency (natural frequency) less than 40 Hz
- ▶ Upper limit frequency (-3 dB) greater than 3 kHz
- ▶ Minimal, linear working stroke +/-2 mm
- ▶ Maximum stroke +/-3 mm

Operating principle

The structure-borne sound control unit J869 generates defined, superposed frequency spectra from the engine's CAN data. These spectra are transferred to the vehicle body by the pulse generator. The generated structure-borne sound is transmitted up to the windscreen. The structure-borne sound is then radiated into the vehicle interior as airborne sound (max. excitation frequency range: approx. 5000 Hz).

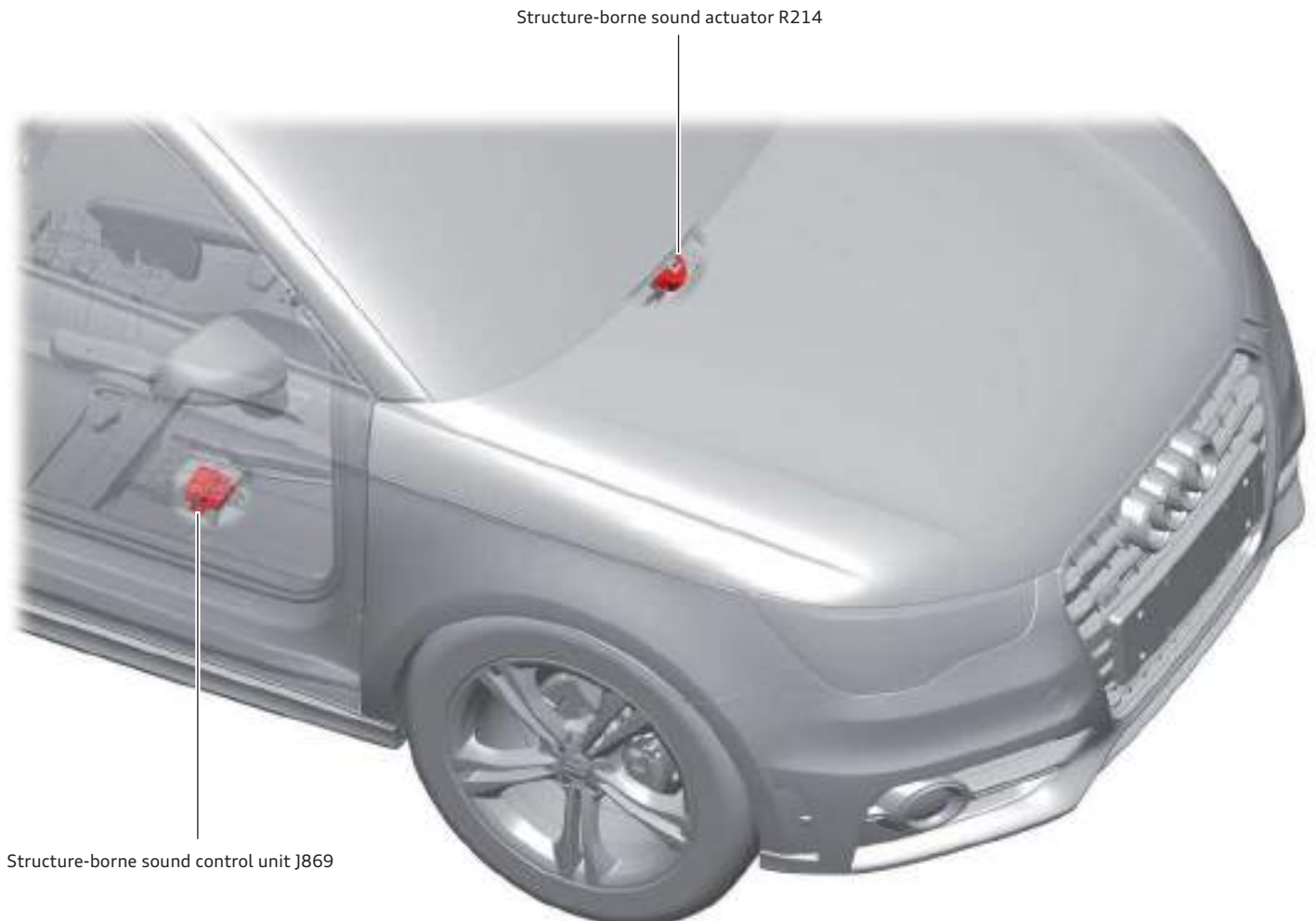

491_066



Note

When steam cleaning the engine, never point the steam jet directly at the structure-borne sound actuator R214!

System overview

The signal generator produces a spectrum of superposed oscillations dependent on the engine's operating state. This analog signal spectrum is amplified by the signal amplifier to produce a power signal and converted to structure-borne sound waves by the structure-borne sound actuator.

The structure-borne sound actuator R214 is mounted to the windscreen cross member. The generated structure-borne sound is thus transmitted directly to the vehicle body and then partially converted to airborne sound. The generated structure-borne sound is transmitted up to the windscreen. The windscreen acts as a membrane and radiates the structure-borne sound into the vehicle interior as airborne sound.

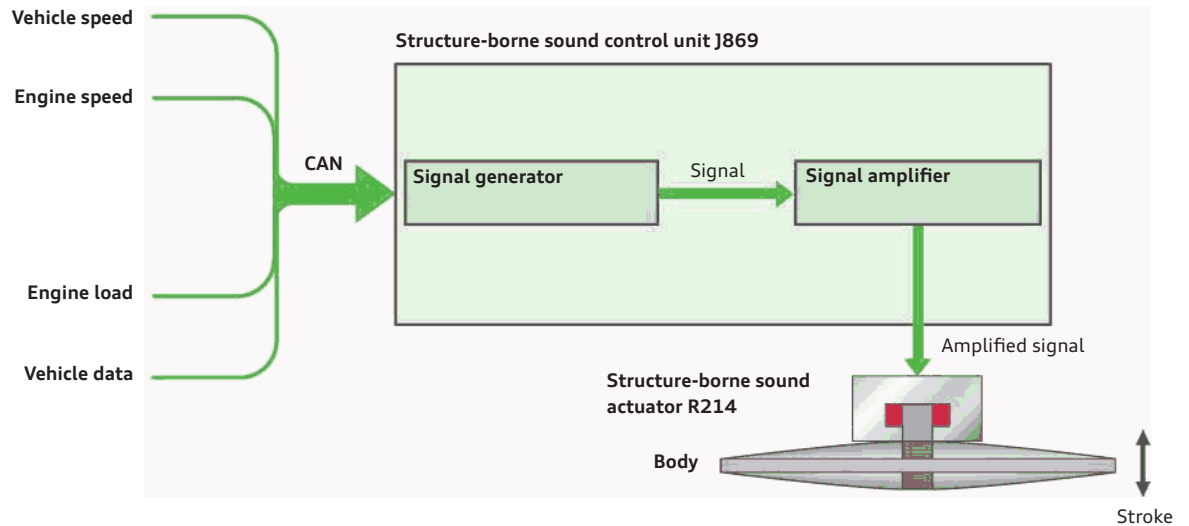

491_063

Function diagram

Legend:

- J533 Data bus diagnostic interface
- J623 Engine control unit
- J869 Structure-borne sound control unit
- R214 Structure-borne sound actuator
- 158 Pos. terminal (term. 15)
- 371 Ground terminal
- B383 Powertrain CAN databus high
- B390 Powertrain CAN databus low

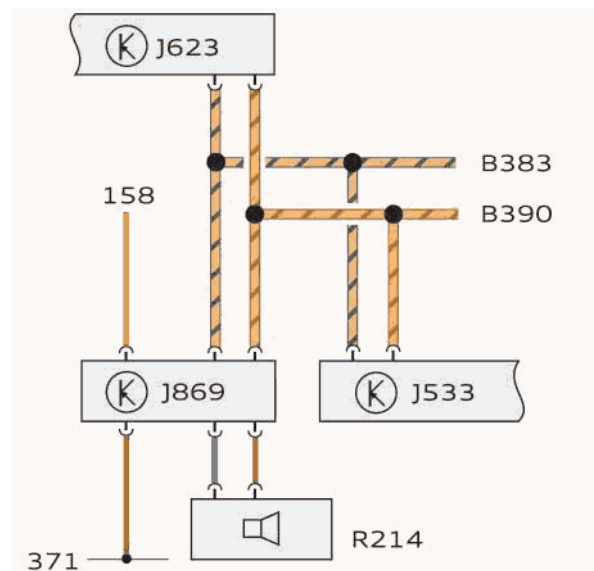

491_064

Diagnostics

The address word of the structure-borne sound control unit J869 is \$A9. The control unit is initialised whenever terminal 15 is powered on.

- ▶ Diagnostic functions
 - ▶ Event memory
 - ▶ Actuator diagnostics
 - ▶ Control unit is not "flashable"
- ▶ System fault:
 - ▶ turn off the actuator
 - ▶ Customer complains of a different sound inside the vehicle
- ▶ Functions:

The speed signal is truncated at high speeds to prevent droning noise. No actuator signal is output during initialisation.

Initialisation

Different vehicles need to be excited differently to produce a good engine sound. Information on the fitted engine type and body type is stored on the powertrain CAN bus and read by listening in. The information transmitter is the data bus diagnostic interface J533.

The structure-borne sound control unit uses information to select a suitable characteristic curve. Given that the structure-borne sound control unit J869 can store multiple characteristic curves, it can automatically identify the vehicle on which it is installed.

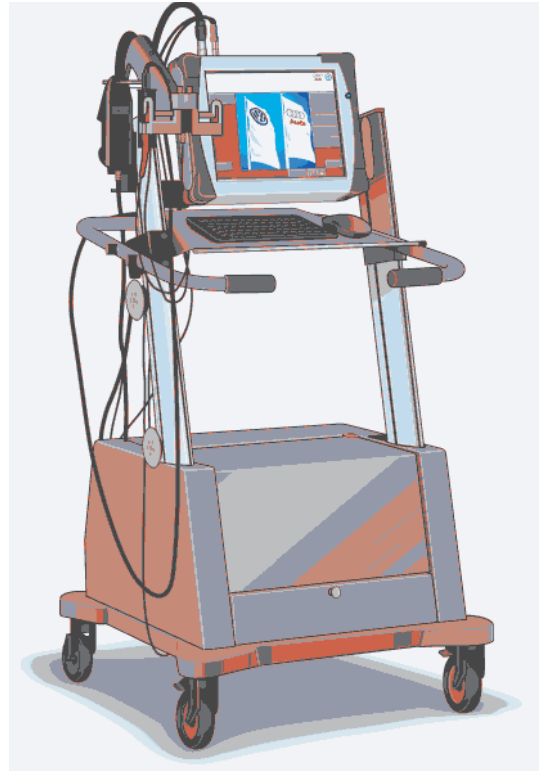

491_065



Note

When replacing the structure-borne sound actuator R214, be sure to apply the correct tightening torque and always use new, self-locking nuts.

Sight glass for seals

Some components of the intake system have sight glasses which can be used to determine whether seals are fitted.

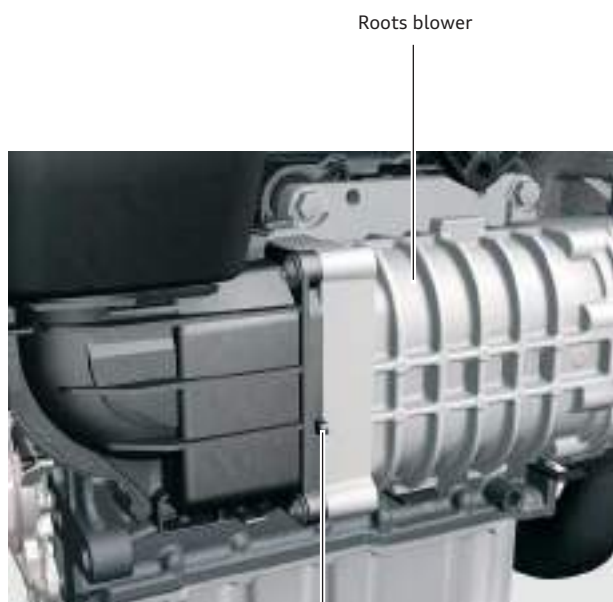

Roots blower

491_043

Check tab for the sealing between the silencer and Roots blower



Sight glass for the sealing between the intake manifold and manifold bottom section

491_044

Control flap control unit J808

Sight glass for the sealing between the intake port and control flap control unit

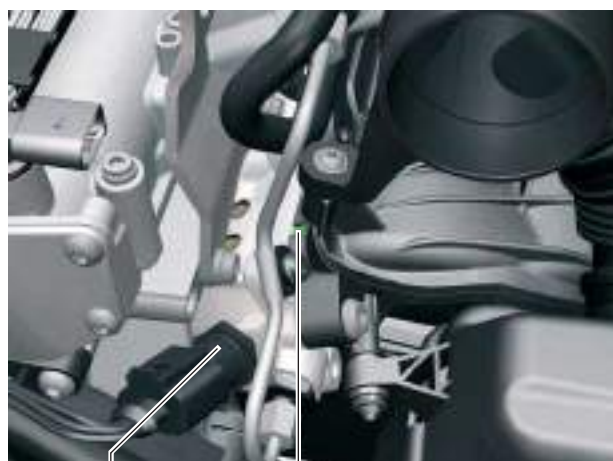

491_045

Fuel pressure sender G247

Sight glass for the sealing between the intake manifold and manifold bottom section



491_046

Sight glass for the sealing between the intake manifold and intake manifold port



Note

You cannot determine whether the sealing is correctly fitted. Refer to the Workshop Manual.

Maintenance operations

Maintenance work	Interval
Engine oil change interval with LongLife oil	Up to 30,000 km or 24 months depending on SID ¹⁾ (dependent on driving style) Engine oil to VW standard 50400
Engine oil change interval without LongLife oil	Fixed interval of 15,000 km or 12 months (whichever comes first) Engine oil to VW standard 50400 or 50200
Engine oil filter change interval	During every oil change
Engine oil change quantity (customer service)	3.6 litres (including oil filter)
Engine oil extraction / drainage	Both are possible
Air filter change interval	90,000 km
Fuel filter change interval	Lifetime
Spark plug replacement interval	60,000 km / 6 years

¹⁾ SID = Service Interval Display

Timing and auxiliary drives

Maintenance work	Interval
Poly V belt replacement interval	Lifetime
Poly V belt tensioning system	Lifetime (automatic tensioner pulley)
Timing gear chain replacement interval	Lifetime
Timing gear chain tensioning system	Lifetime



Note

The specifications in the current service literature always apply.

Glossary

This glossary explains to you all terms written in italics or indicated by an asterisk in this Self Study Programme.

Blow-by gases

Blow-by gases are also referred to as leakage gases. When the engine is running, blow-by gases flow from the combustion chamber and past the piston into the crankcase. This is due to the high pressure inside the combustion chamber and the absolutely normal leakage that occurs around the piston rings. Blow-by gases are extracted from the crankcase by the positive crankcase ventilation system and re-introduced into the combustion chamber.

Downsizing

Increasing efficiency by the use of synergy effects. This entails reducing the scope (size) of material equipment while maintaining performance levels.

Open-deck design

This is a type of cylinder block design in which the cooling ducts are absolutely open upwards. This allows for excellent coolant exchange between the cylinder block and cylinder head. However, cylinder blocks of this type have lower stability. This is ensured by specially designed cylinder head gaskets.

TFSI

This is an abbreviation which stands for Turbo Fuel Stratified Injection - a technology employed by Audi on turbocharged petrol engines for direct fuel injection into the combustion chamber. Fuel is injected at pressures upwards of 100 bar.

Wastegate

The wastegate, also known as the bypass, directs surplus exhaust gases past the turbocharger drive. This allows the turbocharger to shut off or reduce its power output.

Test your knowledge

1. What does the term "downsizing" mean?

- a) Downsizing involves reducing the power output of a large-displacement engine, and thereby also improving fuel economy.
- b) For example, downsizing may be accomplished by reducing the displacement of an engine while maintaining performance levels. This reduces internal friction and improves fuel economy.
- c) Downsizing involves increasing the engine displacement, increasing torque and saving fuel.

2. How many poly V-belts does the TFSI engine have?

- a) It has only a single poly V-belt for driving the auxiliary units.
- b) It has two poly V-belts: one for driving the auxiliary units and one for the Roots blower.
- b) It has three poly V-belts: one for driving the auxiliary units, one for the Roots blower and one for the oil pump.

3. Above which engine speed is the Roots blower no longer activated?

- a) 1500 rpm
- b) 2200 rpm
- c) 3500 rpm

4. Which of the following statements regarding the Roots blower solenoid coupling are correct?

- a) The solenoid coupling is a component part of the coolant pump module.
- b) The solenoid coupling is used to activate the mechanical Roots blower when required.
- c) The solenoid coupling does not require any maintenance.

5. When do the two charging components produce a charge pressure?

- a) The exhaust gas turbocharger produces a charge pressure immediately if the exhaust gas has sufficient energy.
- b) The Roots blower is activated only if the charge pressure produced by the exhaust gas turbocharger is insufficient.
- c) Both charging components are always activated and produce a charge pressure.

6. How is the charge pressure of the charging components regulated?

- a) The charge pressure of the exhaust gas turbocharger is regulated by the turbocharger divert air valve N249 and a pressure cell for charge pressure limitation.
- b) The charge pressure of the charging components is regulated by the throttle valve control unit.
- c) The charge pressure of the roots blower is regulated by the control flap control unit.

7. Which type of oxygen sensor is fitted in the 1.4l 136kW TFSI engine as a pre-catalyst sensor?

- a) A broadband oxygen sensor
- b) A linear oxygen sensor
- c) An NO_x sender

Self Study Programmes

This Self-Study Programme summarises all the key information you need to know about the 1.4l 136kW TFSI engine. You will find further information about the subsystems mentioned in this document in other Self-Study Programmes.

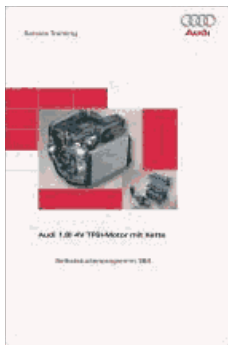

491_037

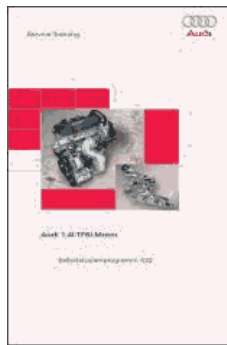

491_038



491_053

SSP 384 SSP 384 Audi chain-driven 1.8l 4V TFSI engine, order number: A06.5S00.29.20

- ▶ TFSI engine technology

SSP 432 The Audi 1.4l TFSI engine, order number: A08.5S00.48.20

- ▶ Engine mechanicals
- ▶ Oil circuit
- ▶ Operating principle of the high-pressure fuel pump

SSP 437 Audi 3.0l V6 TDI engine with Roots blower, order number: A08.5S00.53.20

- ▶ Basic information on Roots blowers



491_067



491_049

SSP 477 Audi A1, order number: A10.5S00.70.20

- ▶ Topology

SSP 485 The Audi 1.2l TFSI engine, order number: A10.5S00.78.20

- ▶ Dual-circuit cooling system

All rights reserved.
Technical specifications are subject to
change.

Copyright
AUDI AG
I/VK-35
service.training@audi.de

AUDI AG
D-85045 Ingolstadt
Technical status 02/11

Printed in Germany
A11.5S00.82.20