

WORKSHOP MANUAL

Alfa 33



Alfa Romeo 

DIREZIONE ASSISTENZA

COMPLETE CAR

£13-



GROUP 00

CONTENTS



GENERAL VIEWS	00-2	APPROXIMATE REFILL CAPACITIES.	00-24
Dimensions and weights.	00-2	ENGINE MAINTENANCE	00-24
MODEL VARIATION	00-3	Basic mechanical system	00-24
IDENTIFICATION DATA.	00-5	Ignition and fuel system.	00-28
LIFTING POINTS AND		Checking CO%	00-29
TOWING	00-6	TROUBLE DIAGNOSIS AND	
Pantograph jack	00-6	CORRECTIONS	00-32
Garage jack and safety stands.	00-7	CHASSIS AND BODY MAINTENANCE .	00-39
Towing.	00-7	Checking fuel and exhaust system . . .	00-39
SPECIAL SERVICE TOOLS.,	00-8	Clutch	00-39
INSTRUCTIONS FOR PRE-DELIVERY		Gearbox-differential	00-39
INSPECTION AND PERIODICAL		Assembly drive shaft	00-39
MAINTENANCE COUPONS.	00-8	Front axle and front suspension.	00-39
Pre-delivery	00-8	Rear axle and rear suspension.	00-40
Checking level	00-8	Checking suspension heights	00-40
Functional tests	00-8	Wheel alignment.	00-42
Cleaning and finishing inspection.	00-8	Brake system	00-43
Maintenance.	00-10	Steering system	00-45
MAINTENANCE SCHEDULE.	00-11	Body	00-4 5
FLUIDS AND LUBRICANTS CHART	00-19	SERVICE DATA AND	
RECOMMENDED FUEL AND		SPECIFICATIONS.	00-45
LUBRICANTS	00-20	Engine maintenance	00-45
Fuel	00-20	Chassis and body maintenance.	00-47
Fluids and lubricants	00-21	SPECIAL SERVICE TOOLS	00-48

GENERAL VIEWS

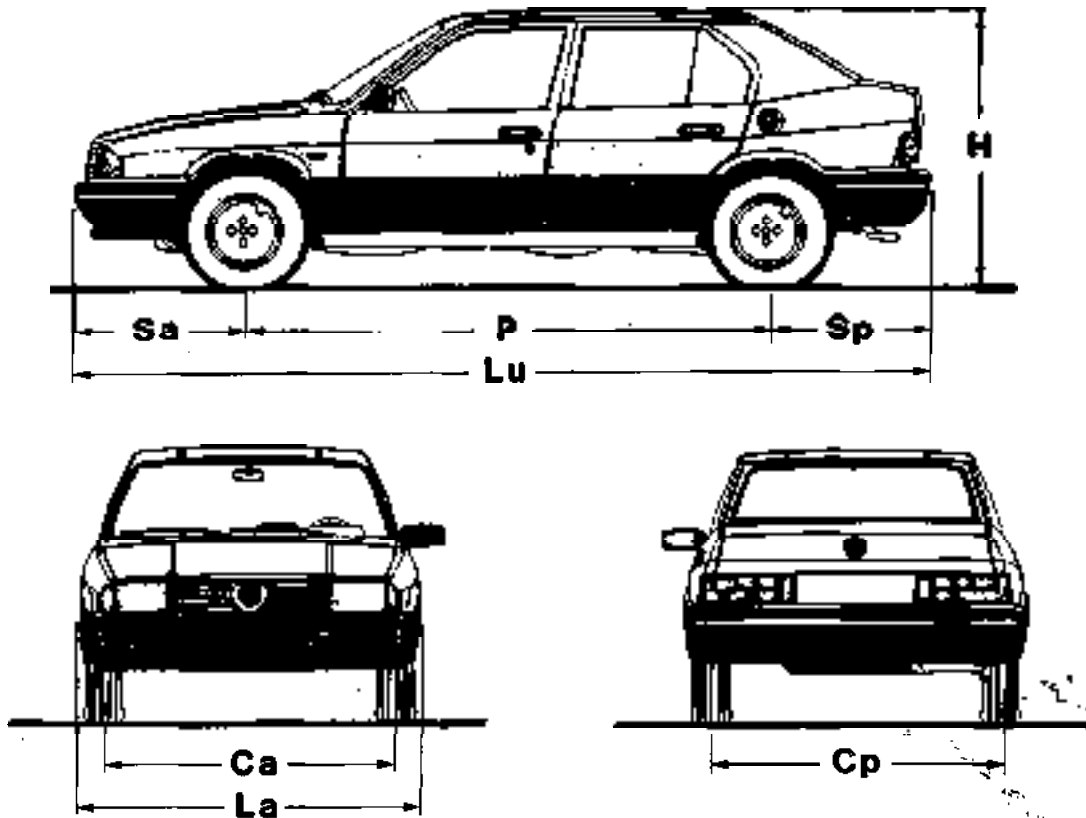

DIMENSIONS AND WEIGHTS

Model		1200	1350	1500
identification number		905.00	905.02 905.03	905.04 - 905.05 905.06 - 905.07
Wheelbase	P	2455 (96.65)		
Track	Front	1392 (54.8)		
	Rear	1359 (53.5)		
Overall length	Lu	4015 (158.07)		
Overhang	Front	800 (31.5)		
	Rear	760 (29.921)		
Overall width	La	1612 (63.46)		
Height (unladen)	H	1305 (51.38)		
Ground clearance		121 (4.76)		
Min. steering radius		4700 (185.04)		
Kerb weight		890 (1962.1)		
Max. allowed gross weight		1315 (2899)		
Payload		425 (936.91)		
Max. allowed axle gross weight	Front	725 (1598.31)		
	Rear	725 (1598.31)		
Max. towing gross weight		1000 (2204.6)		
Seating capacity	Front	2		
	Rear	3		

COMPLETE CAR

MODEL VARIATION

(Except Switzerland, Sweden, Australia)

Model		1200	1350	1500 QUADRIFOGLIO		1500			
Body		5-door saloon		5-door saloon					
Drive		Left	Right	Left	Right	Left	Right	Left	Right
Chassis No.	Identification No.	-- on certification label -- on identification label 905.00		905.02	905.03	905.04	905.05	905.06	905.07
	Type approval No.	-- on identification label 905 A	—	905 A1		905 A2		905 A2	
	Serial No.	-- on intermediate bulkhead label 905 A00	—	905 A1 0		905 A20		905A20	
		-- on intermediate bulkhead label from 05.001 .00	—	from 05.001 .001		from 05.001 .001			
		-- on cylinder block label 305.00 from 000.000.1	—	305.02 from 000.000.1		305.04 from 000.000.1			
Tire dimensions		165/70 SR 13		165/70 SR 13		165/70 SR 13			
Rim dimensions		5J x 13 H2		5J x 13 H2 or 5 1/2J x 13 CH		5J x 13 H2 or 5 1/2J x 13 CH			

IDENTIFICATION DATA

IDENTIFICATION LABELS
(Except Switzerland, Sweden, Australia)

5 - Door Saloon 1200-1350-1500

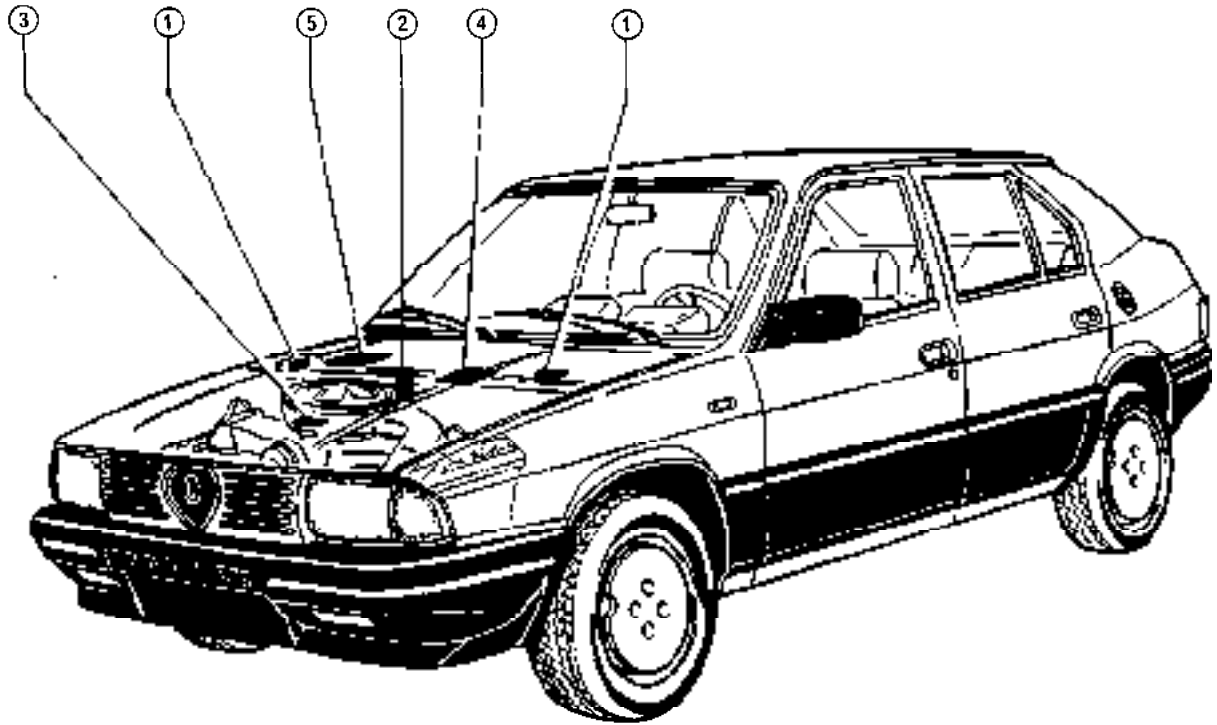

- 1 Certification and identification label (Identification No. and Type approval No.)
- 2 Intermediate bulkhead label (Type approval No. and serial No.)
- 3 Cylinder block label (Engine No.)
- 4 Lubrication data label (see "Fluids and Lubricants" of each group) (Lubrication data)
- 5 Paint label (This label indicates the product used for the first paint) (Paint)

VEHICLE IDENTIFICATION (AND SERVICE) DATA

VEHICLE IDENTIFICATION CODES

A) Chassis numbering

Z A R 9 0 5 A 0 0 0 5 . 0 0 2 . 4 5 8
(1) (3) (2)

(1) Manufacturer identification letters.

(2) Serial number: progressively assigned by Production.

(3) "Type approval number": not for service identification use; for service purposes, use the "type number" which is stamped on identification label along with the "type approval number".

The following is an example of such label.

(4) Identification number: to be

used as vehicle service identification number. This number consists of five figure numbers, divided as follows:
4a) Basic type number: it is assigned to all vehicles having a common design concept (Ex.: 905: Saloon).
4b) Type variant number: it identifies, within the basic type, those vehicles that differ because of some variant that alters their features (Ex.: 905.02 5-door Saloon).

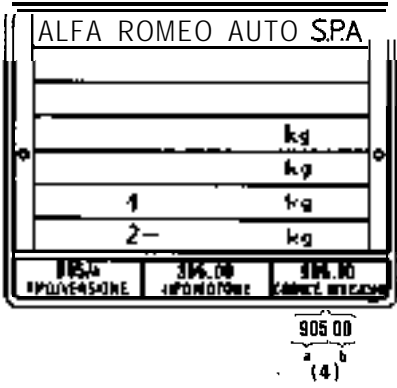

B) Engine numbering

It consists of two sets of figures, namely:

305.00 00045 12
(1) (2)

- (1) Type number: it is assigned to all engines having common general technical characteristics (Ex.: 305.02: 1350 engine with twin carburetor).
- (2) Serial number: progressively assigned by production.

LIFTING POINTS AND TOWING

PANTOGRAPH JACK

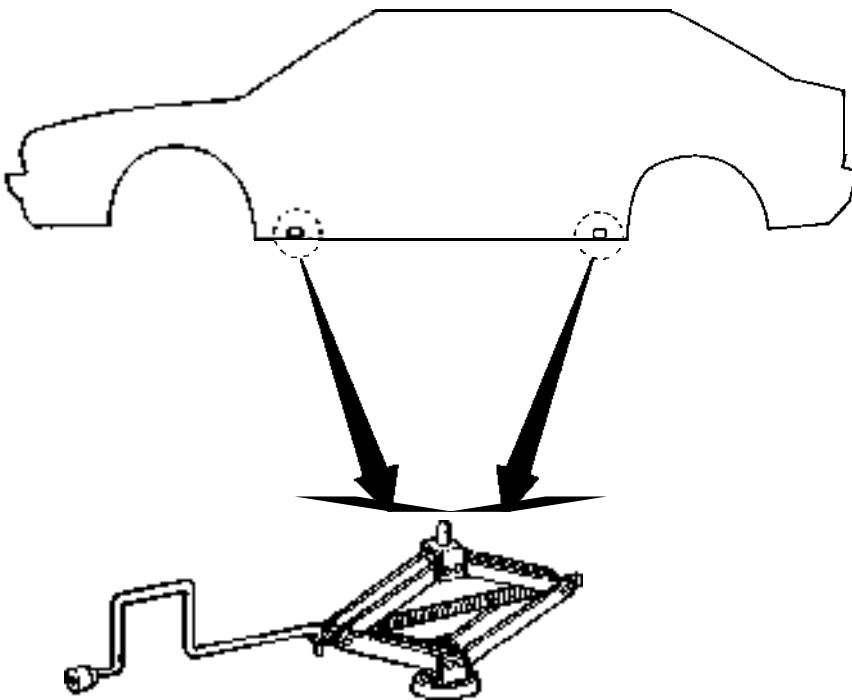

WARNING:

- a. Never get under the vehicle while it is supported only by the jack. Always use safety stands to support frame when you have to work under the vehicle.
- b. Place wheel chocks at both front and back of the wheels diagonally opposite the jack's position.

Fit pantograph jack, supplied with the vehicle, to safety points shown in figure.

GARAGE JACK AND SAFETY STANDS

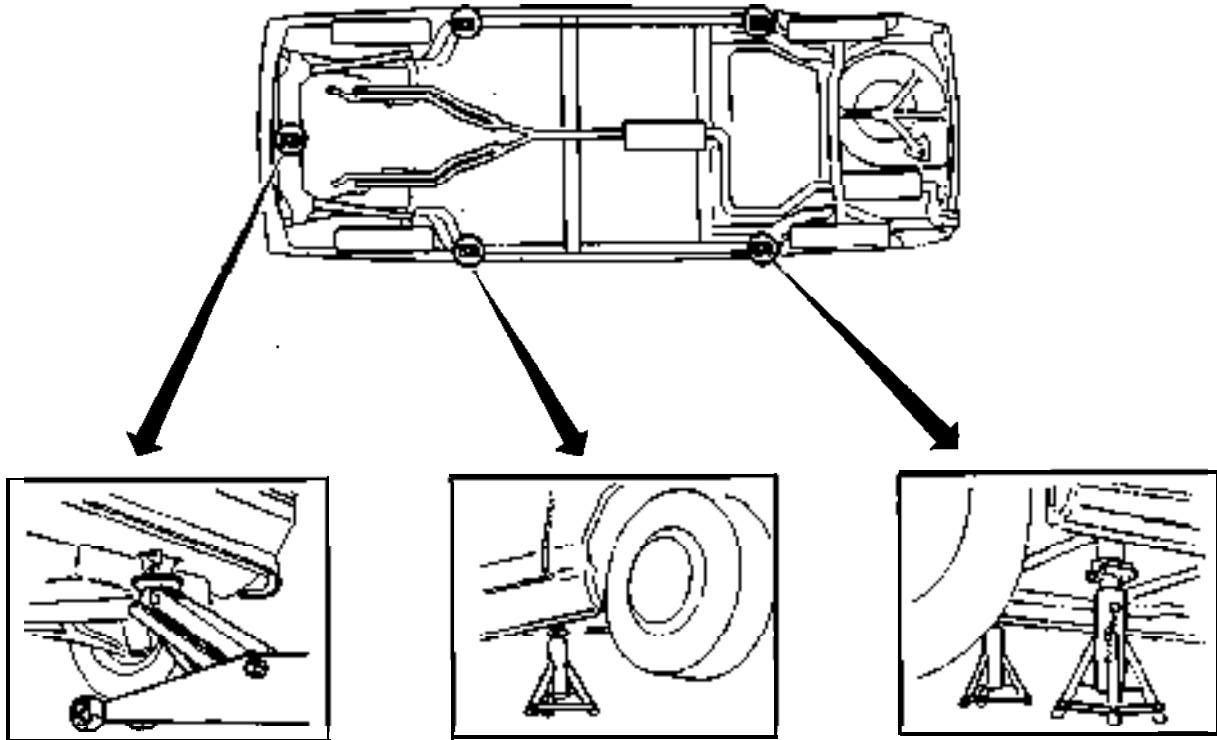

WARNING:

- a. When raising vehicle with garage jack, be sure to support it with safety stands.
- b. When jacking up the rear (front) of the vehicle, place chocks in front (in back) of the front (rear) wheels.

CAUTION:

When raising the vehicle, always place a wooden block under vehicle's lifting points.
Position garage jack and safety stands' in a safe manner under the points shown in the figure.

TOWING

Closely follow Motor Vehicle Regulations regarding vehicle towing.

CAUTION:

- a. Use proper towing equipment to avoid possible damage to the vehicle.
- b. Before towing, make sure that front and rear axes as well as steering system are in good working condition; contrarywise use a dolly.
- c. If vehicle must be towed with its rear wheels raised, front wheels must be placed on a towing dolly.
- d. Set ignition key to "GAR" and do not withdraw it from switch; otherwise antitheft device could become engaged.
- e. Release parking brake and set gearshaft lever to "neutral" before starting to tow the vehicle.
- f. Do not apply lateral forces to towing hook. Keep towing bar or similar devices always in line with the vehicle.
- g. Remember that when vehicle is being towed, there is no vacuum in servobrake; consequently, when braking, greater pressure must be applied onto brake pedal.

SPECIAL SERVICE TOOLS

Special service tools play a very important role in a vehicle's maintenance since they are essential to ensure accurate, reliable and quick service. To this effect, it must be remembered that times taken relevant to the various maintenance operations are computed assuming that said special tools are being used. All special service tools, made

expressly on the manufacturer's design, needed for overhauling, maintenance and repair of models are listed and illustrated in this manual. The identification number is determined by the relevant ordering part number and consists of a letter followed by a five figure number according to the following schedule:

A.0.0000	Special Service Tool
C.0.0000	Tester
U.0.0000	Reamer

Order of the listed tools by the authorized workshop, must be performed according to the usual systems already followed by each Service - net.

INSTRUCTIONS FOR PRE-DELIVERY INSPECTION AND PERIODICAL MAINTENANCE COUPONS

In this chapter are listed and described all pre-delivery and maintenance operations required by ALFA 33 models.

As far as technical specifications regarding each operation are concerned, refer to each section's relevant "Service Data and Specifications" chapter.

PRE-DELIVERY

Pre-delivery inspection of a new vehicle, prior to customer delivery, consists in carrying out all checking operations and tests hereafter described in order to detect and thus eliminate any damage or malfunction.

It goes without saying, however, that when Dealer personnel picks-up the vehicle should perform a visual check in order to:

- make sure that vehicle is in normal driving condition, especially as regards level of fluids and controls in general
- detect any dents or scratches on body or other damage to the vehicle's interior (upholstery)
- make sure nothing is missing, especially factory supplied accessories, spare tire and any parts that are to be fitted on vehicle only prior to customer delivery.

If checking operations show that topping up -as foreseen by this text -

is required, proceed accordingly; such operation will be considered as part of pre-delivery inspection. In case damages or malfunctions other than those herein described are encountered, they will have to be taken care of repair or adjust according to current technical and administrative procedures. As each operation is being carried out, the relevant card must be filled out and then filed together with the sold vehicle's other documents; also the pre-delivery card included in the Instruction Book supplied to the customer must be duly filled out as demonstration of strictly execution of pre-delivery checks.

CHECKING LEVEL

Coolant

- When engine is cold, check level in expansion reservoir. If required, top up to specified max. level.

Engine oil

- Check if level is up to MAX. mark on dipstick (carry out this operation after having parked the vehicle on an even surface and after the engine has been off for a few minutes). If required, top up with specified oil.

Gearbox and Differential oil

- Remove filler cap and check if

oil level reaches the filler lower edge. If required, top up with specified oil and fit cap back.

Brake and clutch fluid

- Check if level in the reservoir is up to max. mark. If required, top up with specified fluid remembering that tins must be sealed and opened only when ready to use..

Be sure to perform this operation with utmost care and cleanliness.

Battery electrolyte

- Check and make sure electrolyte covers the plate upper edge by 5 mm (0,2 in); contrarywise, top up with distilled water.

Windshield washer fluid

- Check if relevant reservoir is full; if required, top up with specified solution.

Tire pressure

- Check tire pressure and, if required, restore to specified values. Use higher p.s.i. for spare tire.

FUNCTIONAL TESTS

Engine starting and idling

- Check if engine starts properly. When engine is warm, check specified idle-rpm.

COMPLETE CAR

Engine controls

- Check and make sure starter control knob works freely, without sticking; further check that when this knob is pushed in, respective device is not at all engaged on carburetor.
- Check accelerator pedal and make sure it does not stick; also check that when pedal is pushed down all the way, throttle valve is fully open.

Brake, clutch and gearbox controls

- With engine running, push brake pedal and check if - after the initial stroke - it comes without elasticity. Also check if parking brake control lever works properly.
- With engine running, push clutch pedal down and make sure that all gearbox speeds engage easily, without sticking and noiselessly.

Tightening wheel screws

- Use a spanner and check if wheel screws, are properly tightened. Also check if screws, are in compliance with vehicle and rim type, as shown in the Spare Parts Catalogue.

Dashboard instruments

- While starting up the engine, check if all electrically controlled instruments work properly (needles are moving): rpm indicator, oil pressure gauge, water temperature gauge, fuel level indicator, and clock.

System circuits tightness

- Visually check circuits of following systems for leaks or evidence thereof: fuel, brake, clutch, and engine cooling.
- Check engine, gearbox and differential for evidence of oil leaks.

Engine cooling electric fan

- Connect and short-circuit wires of radiator thermal contact and check if fan starts and works properly. Also make sure that wires are properly and securely connected to thermal contact.

Heating system

- Check proper working condition of levers controlling heater and outlets for admission of air into the vehicle (open and close).
- Check if electric fan works properly at different speeds and if relevant warning light on the board lights up.

Lights, signal, electrical accessory equipment

- With ignition key set to "MAR" check if lights outside and inside the vehicle, as well as relevant warning lights, go on: front and rear parking lights, number plate lights, direction indicators and emergency flasher, stop lights, high and low beam headlights, headlights flasher, reverse gear lights, rear fog lights inside ceiling lamp (through manual as well as door switch), instrument cluster light.
- Check proper working condition of following warning lights: alternator, fuel reserve, oil pressure, brake fluid level, parking brake on, starter on, defroster on, cooling water temperature.
- Check proper operation of horns and cigarette lighter.

Windshield and rear window wiper and washer

- After having installed wiper blades, check if windshield wiper works properly at both speeds as well as it is set to intermittent operation.
- Operate the windshield washer and check if sprayer jets are normal and properly directed toward the windshield's higher section.

Locks, hinges, windows

- Check proper working condition of all door locks (close, lock, open from inside and outside). Check in the same manner also locks of engine and back door.
- Check door and bonnet hinges for smooth noiseless operation.
- Check if windows can be opened and closed all the way without sticking and noiselessly.

Doors and bonnets

- Visually check all weather-stripping for tight fit and make sure they are not damaged, out of shape or dirty.
- See if doors and bonnets are aligned and centered with relevant openings.

Seats, seat belt and accessory equipment

- After having removed relevant protecting covers, inspect seats checking if they slide freely on tracks without sticking and noiselessly. Also check proper working condition of seat and head-rest adjusting devices.
- Check if seat belts and relevant retractors are in good working condition.
- Check inside and outside rear-view mirrors making sure they swing easily and stay firmly in place when set; also check snap switch on mirror for day/night driving.
- Check maneuverability of sunvisors, ashtrays, glove compartment and any other accessory.

CLEANING AND FINISHING INSPECTION

Exterior cleaning

- If required, dewax the vehicle using suitable products and procedures; wash the vehicle's exterior with a solution of water and shampoo, rinse it thoroughly and dry it. Finish up cleaning by removing any stubborn spots by means of suitable compounds.

Paint

- Visually and thoroughly check all painted surfaces and remove accidental or manufacturing flaws, if any.

Exterior/Interior mouldings and fittings

- Visually check all vehicle's out-

side parts: bumpers, mouldings, grills, headlight rims, letters and emblems making sure they are securely fitted, and have no spots or dents.

Verify all upholsteries (roof, carpets, panels etc ..) removing possible stains or scratches.

Factory issued accessory equipment

- Check if following items are in their proper place in the vehicle: tool kit, spare tire, jack, Instruction Book and Service Book.

MAINTENANCE

Maintenance operations consist in checking and restoring proper working condition of some parts of the vehicle which are most likely to become worn or out-of-adjustment as a consequence of the vehicle's normal use.

A list of various operations to be performed at different intervals, as shown in the chart that follows, is included in the coupons of the Service Book which accompanies each vehicle.

Coupons will have to be stamped by the Service Organisation Agency to show that specified maintenance operations have been carried out. Just as for pre-delivery inspection, should topping UP or change of fluids and lubricants - as described in the text - become necessary, they will be considered as part of maintenance operations. In case damages or malfunctions other than those listed are encountered, they will be taken care of repair of adjust according to current technical and administrative procedures.

MAINTENANCE SCHEDULE

(Except Switzerland, Sweden, Australia)

No	OPERATION	A	Km/1000					Notes
			1)					
			20	40	60	80	100	
00-10	Test vehicle	X						
00-20	Check all bolts for tightness	X						
01-10	Change engine oil and oil filter; check lubrication system for leaks	X	X	X	X	X	X	(2)
01-20	Check valve clearance and adjust, if necessary	X	X	X	X	X	X	
01-40	Check tension and soundness alternator drive belt and adjust, if necessary	X	X	X	X	X	X	
01-50	Replace alternator drive belt				X			
01-60	Replace camshaft drive belts				X			
04-10	Check fuel system for leaks	X	X	X	X	X	X	
04-20	Replace air cleaner cartridge		X	X	X	X	X	(3)
04-30	Replace fuel filter	X		X	X	X	X	
04-40	Clean carburetor jets and PVC system flame trap	X	X	X	X	X	X	
04-60	Check idle speed and CO% adjust, if necessary	X	X	X	X	X	X	
04-60	Check accelerator cable adjust if necessary	X						
05-10	Check ignition timing adjust if necessary	X	X	X	X	X	X	
05-20	Replace spark plugs		X	X	X	X	X	(4)
07-10	Check oil level; check cooling system for leaks	X	X	X	X	X	X	(5)
13-10	Change gearbox oil	X		X				
3-20	Check gearbox oil level		X		X		X	
17-10	Check drive shaft and steering box boots for cracks or wear	X	X	X	X	X	X	
21-10	Check front wheel bearings, adjust if necessary	X						
22-10	Inspect brake system	X	X	X	X	X	X	
22-20	Check brake pads for wear; replace as required		X	X	X	X	X	(6)

(Except Switzerland, Sweden, Australia)

No.	OPERATION	A (1)	Km/1000					Notes (11)
			20	40	50	80	100	
22-21	Inspect rear brake drums, check shoe lining for wear and replace as required		X	X	X	X	X	(6)
22-30	Change brake and clutch fluid			X		X		(7)
22-40	Check level of fluid in both brake and clutch reservoirs	X	X		X		X	(8)
22-50	Check parking brake stroke, adjust as required	X	X	X	X	X		
28-10	Check tire pressure	X	X	X	X	X	X	(5)
40-10	Check battery electrolyte level and top up if necessary; also check terminals for proper tightness and lubrication	X	X		X		X	(8)
40-20	Check headlights dimming and adjust as required	X						
56-10	Lubricate floor and bonnet hinges; adjust striker plates	X	X	X	X	X	X	

- (1) A = 1500 ± 1700 km
- (2) To be performed also at 10, 20, 50, 70, and 90 km/1000 and in any case once a year
Check oil level frequently when refuelling
- (3) Check and clean carburettor at km intervals (mileage) stated in item (2) above and even more frequently if driven in very dusty areas
- (4) Check spark plugs at km intervals (mileage) stated in item (2) above
- (5) Check frequently when refuelling
- (6) To be performed also at km intervals (mileage) stated in item (2) above and even more frequently when driving under particular stress conditions (sport driving) or on hilly roads
- (7) To be performed in any case once a year
- (8) To be performed also at km intervals (mileage) stated in item (2) above

MAINTENANCE SCHEDULE

(Swiss version)

No.	OPERATION	A	Km/1000						Notes (1)
			10	20	40	60	80	100	
00-10	Test vehicle	X							
01-05	Check all engine bolts for tightness	X							
01-10	Change engine oil and oil filter; check lubrication system for leaks	X	X	X	X	X	X	X	(2) E
01-20	Check valve clearance and adjust, if necessary	X	X	X	X	X	X	X	E
01-30	Clean the PCV system		X	X	X	X	X	X	E
01-40	Check tension and soundness of alternator drive belt and adjust, if necessary	X	X	X	X	X	X	X	
01-50	Replace alternator drive belt				X				
01-60	Replace worn/damaged drive belts				X				E
04-10	Check fuel system for leaks	X	X	X	X	X	X	X	E
04-20	Replace air cleaner cartridge		X	X	X	X	X	X	(3) E
04-40	Clean carburetor jets	X	X	X	X	X	X	X	E
04-50	Check idling rpm fast idle and CO % adjust, if necessary	X	X	X	X	X	X	X	E
04-60	Check accelerator cable adjust if necessary	X	X	X	X	X	X	X	
04-75	Check air intake temperature control device		X	X	X	X	X	X	E
04-70	Check starter control functioning	X	X	X	X	X	X	X	E
05-10	Check ignition timing	X	X	X	X	X	X	X	E
06-20	Replace spark plugs			X	X	X	X	X	(4) E
07-10	Check engine coolant level (no leaks). Possible topping up	X	X	X	X	X	X	X	(5) E
07-20	Change engine cooler and check cooling system for leaks			X				X	(6) E
13-10	Change gearbox - differential oil	X			X			X	
13-20	Check gearbox - differential oil level		X					X	
17-10	Check drive shafts and steering box boots for cracks or wear	X	X	X	X	X	X	X	X

COMPLETE CAR

(Swiss version)

No	OPERATION	Km/1000											Notes			
		A	1	2	3	4	5	6	7	8	9	10				
21-10	Check front wheel torque; adjust if necessary	X														
22-10	Inspect brake system	X														
22-30	Check front brake pads and rear drum friction packets possible replacement									X	X	X	X	X	X	(7)
22-25	Check brake booster vacuum hose for sound condition									X	X	X	X	X	X	E
22-30	Change brake fluid															(8)
22-40	Check level of fluid in both brake and clutch reservoirs	X								X	X	X	X	X	X	(9)
22-50	Check parking brake stroke; adjust as required									X	X	X	X	X	X	
28-10	Check tire pressure	X								X	X	X	X	X	X	(5)
40-10	Check battery electrolyte level and top up if necessary; also check terminals for proper tightness and lubrication															
40-20	Check headlights aiming and adjust as required	X														
50-10	Lubricate door and bonnet hinges; adjust struts/plates	X														

- 11) A = 1300 + 1700 Km
- 12) To be performed at 30, 50, 70, 90, Km/1000 and in any case once a year.
Check oil level frequently when refuelling
- 13) Check and clean cartridge at Km intervals (mileage) stated in item 12) above and with more frequency if driving in very dusty areas
- 14) Check spark plugs at 10, 30, 50, 70, and 90 Km/1000
- 15) Check frequency when refuelling
- 16) Every two years whichever occur first
- 17) To be performed at Km/1000: 10, 20, 50, 70, 90 and even more frequently when driving under particular stress conditions (sport driving) or on hilly roads.
- 18) Once a year whichever comes first
- 19) Also at Km/1000: 10, 30, 50, 70, 90.
- E Operation relevant to emission control

MAINTENANCE SCHEDULE

(Sweden version)

No.	OPERATION	A	Km/1000					Notes (1)
			20	40	60	80	100	
00-10	Test valves	X						
00-20	Check all bolts for tightness	X						
01-10	Change engine oil and oil filter; check lubrication system for leaks	X	X	X	X	X	X	(2)
01-20	Check valve clearance and adjust, if necessary	X	X	X	X	X	X	
01-30	Clean the PCV system		X	X	X	X	X	
01-40	Check tension and soundness of air pump and alternator drive belt and adjust, if necessary	X	X	X	X	X	X	
01-50	Replace air pump and alternator drive belt				X			
01-60	Replace camshaft drive belts				X			
04-10	Check fuel system for leaks	X	X	X	X	X	X	
04-20	Replace air cleaner cartridge and air pump cleaner		X	X	X	X	X	(3)
04-30	Replace fuel filter	X	X	X	X	X	X	
04-40	Clean carburetor jets	X	X	X	X	X	X	
04-50	Check idler-arm leg idle and CO% adjust, if necessary	X	X	X	X	X	X	
04-60	Check accelerator cable adjust if necessary	X	X	X	X	X	X	
04-70	Check automatic starting device; adjust if necessary	X	X	X	X	X	X	
04-75	Check air Intake temperature sensor device		X	X	X	X	X	
05-10	Check ignition timing adjust if necessary	X	X	X	X	X	X	
05-20	Replace spark plugs		X	X	X	X	X	(4)
07-10	Check engine coolant level, (to inspect for leaks)	X	X	X	X	X	X	(5)
07-00	Change engine coolant and check cooling system for leaks		X			X		(6)
13-10	Change gearbox oil	X	X	X	X	X	X	
3-20	Check gearbox oil level		X		X		X	

MAINTENANCE SCHEDULE

(Australia version)

No.	OPERATION	A	Km/1000																		
			10	20	30	40	50	60	70	80	90	100									
1	Change engine oil and filter	⊗	⊗	⊗	⊗	⊗	⊗	⊗	⊗	⊗	⊗	⊗	⊗	⊗	⊗	⊗	⊗	⊗	⊗	⊗	
2	Check battery and top up electrolyte level. If necessary, check terminals for proper tightness and lubrication	△	△	△	△	△	△	△	△	△	△	△	△	△	△	△	△	△	△	△	△
3	Check drive shaft and steering box bolts for cracks or wear	X	X	X	X	X	X	X	X	X	X	X	X	X	X	X	X	X	X	X	X
4	Check tire pressure	X	X	X	X	X	X	X	X	X	X	X	X	X	X	X	X	X	X	X	X
5	Check engine coolant level; possible topping up	X	X	X	X	X	X	X	X	X	X	X	X	X	X	X	X	X	X	X	X
6	Check front brake pads and rear drum friction gaskets; possible replacement	X	X	X	X	X	X	X	X	X	X	X	X	X	X	X	X	X	X	X	X
7	Check level of fluid in both brake and clutch reservoirs	X	X	X	X	X	X	X	X	X	X	X	X	X	X	X	X	X	X	X	X
8	Check level of gearbox/differential oil	X	X	X	X	X	X	X	X	X	X	X	X	X	X	X	X	X	X	X	X
9	Check oil system fuel system and cooling circuit for leaks; check vacuum hoses and connections for soundness	X	X	X	X	X	X	X	X	X	X	X	X	X	X	X	X	X	X	X	X
10	Check valve clearance and adjust, if necessary	X	X	X	X	X	X	X	X	X	X	X	X	X	X	X	X	X	X	X	X
11	Check tension and speediness of air pump and alternator drive belt and adjust if necessary	X	X	X	X	X	X	X	X	X	X	X	X	X	X	X	X	X	X	X	X
12	Check ignition timing adjust if necessary	X	X	X	X	X	X	X	X	X	X	X	X	X	X	X	X	X	X	X	X
13	Check air intake temperature control device	X	X	X	X	X	X	X	X	X	X	X	X	X	X	X	X	X	X	X	X
14	Check idle rpm, fast idle and CO % adjust if necessary	X	X	X	X	X	X	X	X	X	X	X	X	X	X	X	X	X	X	X	X
15	Clean the PCV system	X	X	X	X	X	X	X	X	X	X	X	X	X	X	X	X	X	X	X	X
16	Replace fuel filter	X	X	X	X	X	X	X	X	X	X	X	X	X	X	X	X	X	X	X	X
17	Check camshaft driving belts for soundness and tension; adjust if necessary	X	X	X	X	X	X	X	X	X	X	X	X	X	X	X	X	X	X	X	X
18	Check door and lid hinges and locks for operation and lubrication	X	X	X	X	X	X	X	X	X	X	X	X	X	X	X	X	X	X	X	X
19	Inspect brake hydraulic system	X	X	X	X	X	X	X	X	X	X	X	X	X	X	X	X	X	X	X	X

FLUIDS AND LUBRICANTS CHART

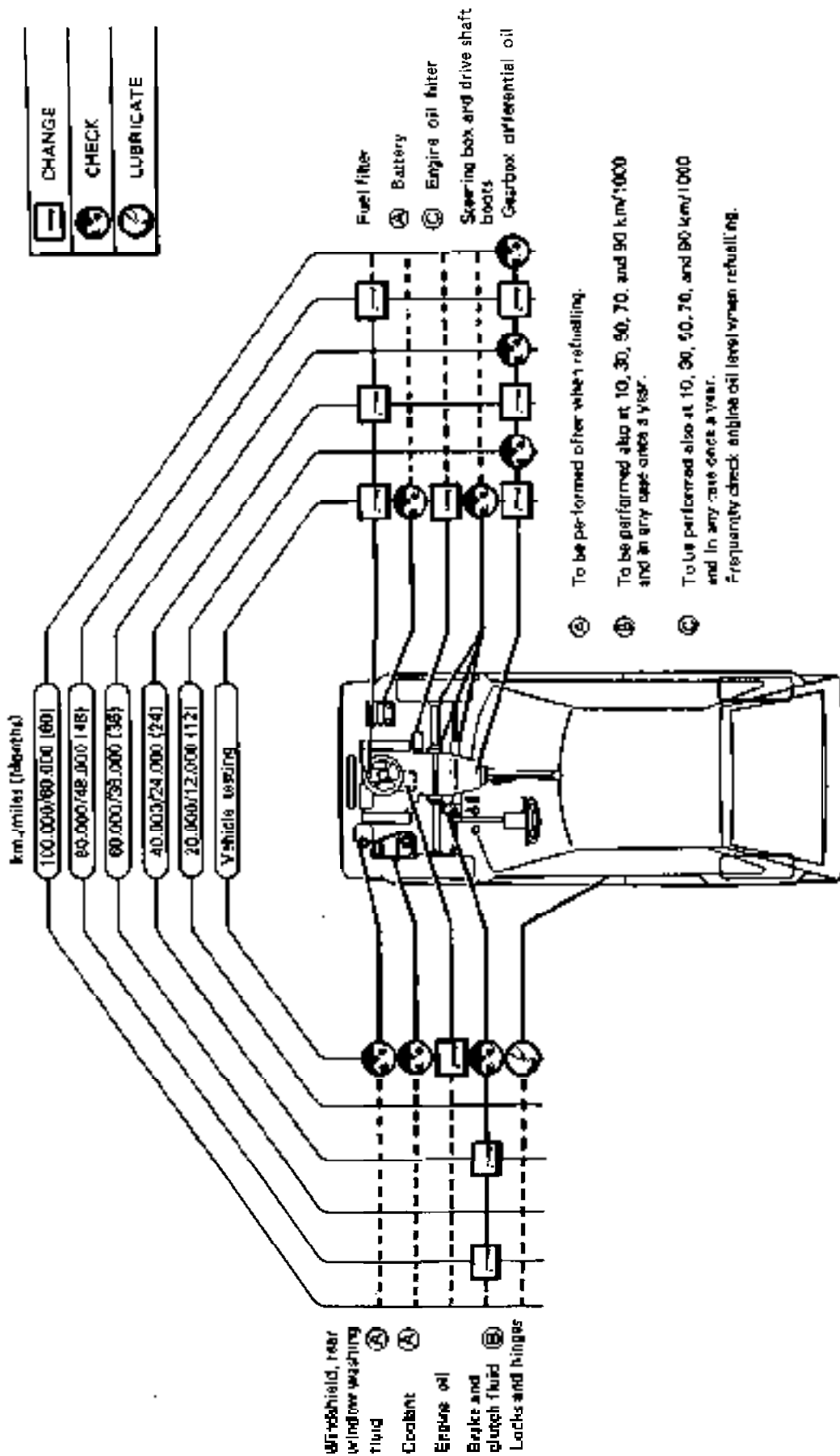

RECOMMENDED FUEL AND -LUBRICANTS

FUEL

To ensure proper engine operation, use petrol with a ≥ 98 Octane Rating (R.M.) and a ≤ 11 sensitivity (1).

(1) Difference between Research Method Octane Rating and Motor Method Octane Rating.

COMPLETE CAR

FLUIDS AND LUBRICANTS

Type	Application	Designation			Notes	
		API #	IP #	Other *		
OIL	Engine - 01	SAE SAE J 306 a ASTM D 56 API SE	SAE 2000	Super Motor Oil	Environmental parts perature - 18° ± 40°C 10 ± (104°F)	
			SAE 10W/50			
			F 1 Rotax MP SAE 80W/90	Pontiac HD SAE 80W/90		Environmental parts perature - 30° ± 40°C - 22° ± 104°F
			F 1 Rotax MP SAE 80W/90	Pontiac HD SAE 80W/90		Environmental parts perature - 30° ± 40°C - 22° ± 104°F
	Gearbox - Differential - 13	SAE J 306 a API GL-5	F 1 Rotax MP SAE 80W/90	Pontiac HD SAE 80W/90	Environmental parts perature - 30° ± 40°C - 22° ± 104°F	
			F 1 Rotax MP SAE 80W/90	Pontiac HD SAE 80W/90	Environmental parts perature - 30° ± 40°C - 22° ± 104°F	
	Front suspension - 21	SAE J 306 a API GL-5	F 1 Rotax MP SAE 80W/90	Pontiac HD SAE 80W/90	Environmental parts perature - 30° ± 40°C - 22° ± 104°F	
			F 1 Rotax MP SAE 80W/90	Pontiac HD SAE 80W/90	Environmental parts perature - 30° ± 40°C - 22° ± 104°F	
	Rear suspension - 25	SAE J 306 a API GL-5	F 1 Rotax MP SAE 80W/90	Pontiac HD SAE 80W/90	Environmental parts perature - 30° ± 40°C - 22° ± 104°F	
			F 1 Rotax MP SAE 80W/90	Pontiac HD SAE 80W/90	Environmental parts perature - 30° ± 40°C - 22° ± 104°F	
Engine fuel system - 04	N.L.G.I. n. 1	F 1 Grease 15		Basic substance: Al - Ca		
GREASE	Engine ignition 05			ISECO: Molykote A		
	Clutch - 12	N.L.G.I. n. 3 N.L.G.I. n. 1	F 1 Grease 33 FD	Autogrease FD	Basic substance: Bismaleic Poly(hept Basic substance: Al-Ca	
			F 1 Grease 15			
	Gearbox - Differential - 13	N.L.G.I. n. 3 N.L.G.I. n. 1 N.L.G.I. n. 2	F 1 Grease 33 FD		ISECO: Molykote BR2 ISECO: Molykote Parts G	
			F 1 Grease 15			

COMPLETE CAR

Type	Application	Classification	Denomination		Notes
			AGIP *	P *	
GREASE	Differential - 17				Basic substances. Li
				ISOCO: Molykote VM2461/C OPTIMACK: Olanamoly 2 LN 584	
	Front suspension - 21	N.L.G.I. n. 3	F 1 Grease 33 FD	Autogrease FD	Basic substances. Benzonitrile Polythene
				UNION CARBIDE CHEMI- CALLS COMPANY: Ucon Lubricant 50 HB 5100 MILL OIL: Lubricant for electronic seals	
	Front and Rear Brakes - 22	N.L.G.I. n. 1	F 1 Grease 15		Basic substances: Al - Ca
				ATE: Brandy Ince Pasta DBA	
	Steering System - 23	N.L.G.I. n. 3	F 1 Grease 33 FD	Autogrease FD	
				UNION CARBIDE CHEMI- CALLS COMPANY: Ucon Lubricant 50 HB 5100 MILL OIL: Lubricant for electronic seals	
	Rear suspension - 25	N.L.G.I. n. 3	F 1 Grease 33 FD	Autogrease FD	Basic substances: Benzonitrile Polythene
			F 1 Grease 15		Basic substances. Al - Ca
	Wheels and Tires - 26				
					UNION CARBIDE CHEMI- CALLS COMPANY: Ucon Lubricant 50 HB 5100 MILL OIL: Lubricant for electronic seals

APPROXIMATE REFILL CAPACITIES

APPROXIMATE REFILL CAPACITIES		kg (lb)	l (Imp gal)
FUEL TANK			50 (11)
FUEL RESERVE		—	6.5 (1.43)
COOLANT		—	7.3 (1.61)
ENGINE OIL SUMP	With filter	3.6 (7.94)	
	Without filter	3.15 (6.94)	
GEARBOX-DIFFERENTIAL OIL		2.3 ÷ 2.4 (5.1 ÷ 5.3)	—
CONCENTRATE ANTI FREEZE QUANTITY DEPENDING ON TEMPERATURE	E — 10°C (14°F)	—	1.8 (0.40)
	— 20°C (-4°F)	—	2.6 (0.57)
	— 35°C (-31°F)	—	3.65 (0.80)
ANTIFREEZE QUANTITY READY FOR USE → — 20°C (-4°F)		—	7.3 (1.61)
CAM SHAFT SUPPORT SUMPS OIL Kg 0.250 (lb 0.55) FOR EACH SUPPORT (REFILL TO BE CARRIED OUT IN CASE OF DISASSEMBLIES ONLY-COMPLETLY DRY SUPPORTS		0.5 (1.1)	

ENGINE MAINTENANCE

BASIC MECHANICAL SYSTEM

CHECK AND POSSIBLE ADJUSTMENT OF VALVE CLEARANCE

Following operations must be performed while engine is cold.

1. Disassemble spark plugs, remove camshaft support cover and, by means of a syringe, suck oil from tank.
2. Using the feeler gauge **C.6.0168** check clearance between cam resting radius and cup crown making sure it is within specified value.

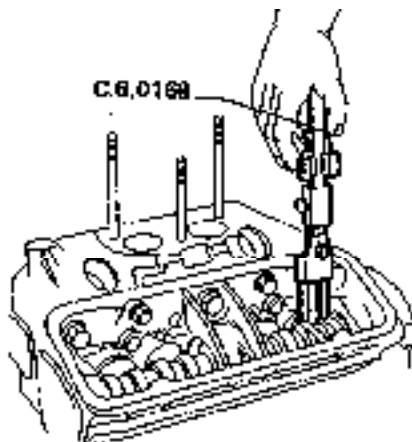

2. Insert the key **A.50193** into proper hole on camshaft,
3. Further rotate crankshaft so that camshaft hole is in line with the adjusting screw on the cup.
4. Suitably rotate the cup involved in the adjusting operation as well as the one next to it so that relevant cavities will face each other.
5. Introduce tool **A.2.0278** for retaining of valve cups in order to prevent rotation of cups during clearance adjustment (tool does not prevent axial sliding).

Valve clearance (cold engine)

Intake

0.35 ÷ 0.40 mm (0.014 ÷ 0.016 in)

Exhaust

0.45 ÷ 0.50 mm (0.018 ÷ 0.020 in)

In case clearance is not within the prescribed values, carry out adjustment operating as follows:

1. Rotate crankshaft till piston is in its compression stroke (valve closed).

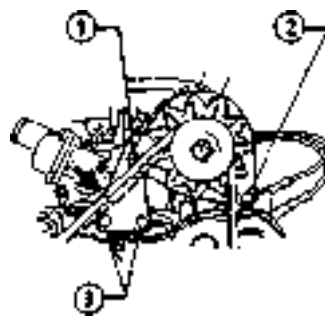
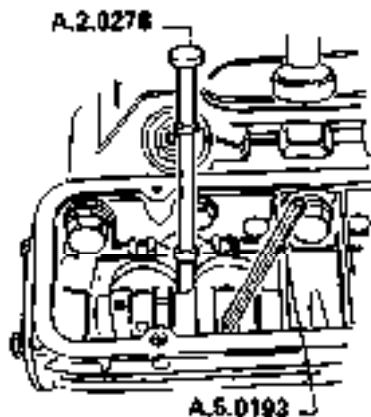

1 Bolt
2 Bolt
3 Screw

Replacing timing belts with engine on car

6. Interpose tool C.6.0168 between taper bucket upper part and cam minimum radius and, by means of wrench A.5.0193, operate until the prescribed clearance is obtained.
7. For better security check clearance after having removed previously inserted cup locking pin.
8. Repeat the procedure for each valve of the two heads.
9. At the end of operation, restore the tank oil level and reassemble cover and spark plugs.

CHECKING, REPLACING AND ADJUSTING DRIVE BELTS

Alternator and water pump control belt

Inspect belt for cracks or damage. Replace it if necessary. Push on belt longest section, located between engine pulley and alternator pulley, applying an 79 N (8 kg; 3.63 lb) load and verify relevant deflection which should be of 15 mm (0.59 in); contrarywise proceed to adjust belt tension as follows.

7. Loosen bolts ① and ② as well as screws ③ that secure alternator support bracket to the engine's front cover.
2. Move the alternator so as to either stretch or slacken the belt and then tighten bolt ①.
3. Check again belt tension and then tighten all previously loosened bolts.

REMOVAL

1. Disconnect electric fan wiring, loosen relevant screws ① and remove fan from radiator through lower channel ②.

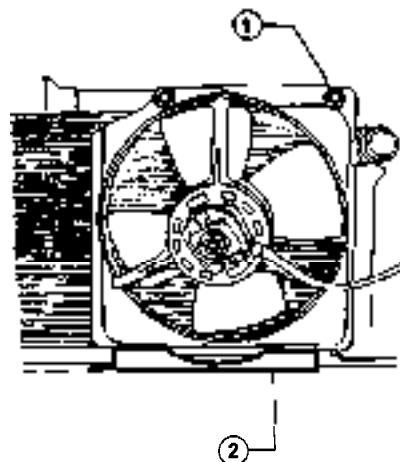

1 Screw
2 Channel

2. Remove spark plugs, alternator and water pump control belt.
3. Remove camshaft belts plastic covers.
4. Remove camshaft support covers.
5. Remove timing plastic cover located on cylinder block rear cover, and rotate crankshaft till piston in no. 1 cylinder is set in top dead center on its combustion -stroke. Such correct position is achieved when the T-shaped reference mark ② on flywheel is in line with the mark on rear cover ①.

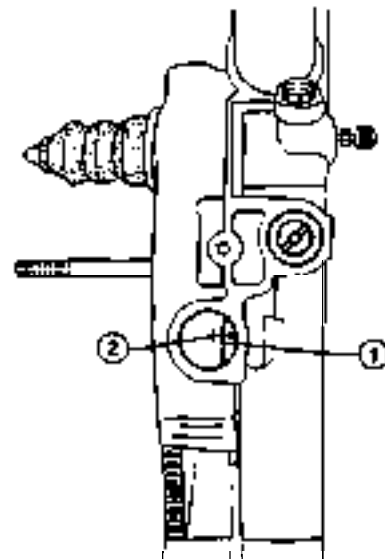

1 Mark on rear cover
2 T-shaped reference mark

6. Loosen idler pulleys lock nuts ① and then press idler pulleys ② so as to overcome tension load on belts. Tighten nuts ① while in this position.

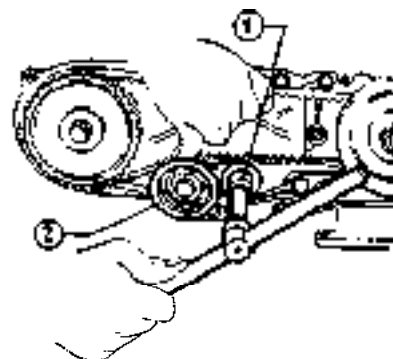

1 Lock nut
2 Idler pulley

7. Now remote first the right hand cogged belt and then the left hand belt from camshaft and crankshaft pulleys.

ASSEMBLY

CAUTION:
Check again engine timing proceeding as per step 5. above.

1. Rotate camshafts till reference marks stamped on same are in line with those stamped on relevant support.

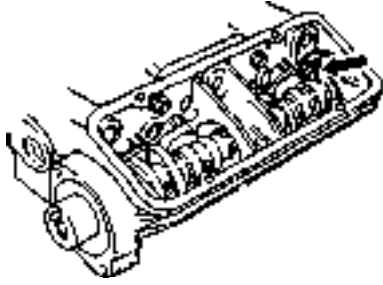

2. Key camshaft control belts onto crankshaft and camshaft pulleys starting with the one of the left hand cylinder head.

(1) Belt keying must take place while belt pulling section (opposite the idler pulleys) is fully stretched.
 (2) Loosen idler pulleys lock nuts all the way and then tighten them again.
 (3) Let driving shaft rotate in the functioning direction so as to allow belt to set on pulleys.

(4) Set, one by one, the camshafts to the neutral position, then unloosen nuts securing backstand, press a few times on them and secure nuts to the prescribed torque.

(5) Rotate crankshaft a few times in its working direction so that belts may take up their final position.

Rotate camshafts till they are in neutral position: loosen idler pulleys lock nuts pressing idler pulleys a few times, and then tighten relevant nuts according to specified torque.

Rotate crankshaft a few times in its working direction thus allowing belts to settle on pulleys, and then repeat above described tension checking operation while positioning camshafts one at the time - with cups disengaged.

T: Tightening torque
 Idler pulley lock nut
 (cold engine)
 37 ÷ 46 N·m
 (3.8 ÷ 4.7 kg·m
 27.49 ÷ 33.98 ft·lb)

3. Check again engine timing.
4. Fit back camshaft support covers, alternator and water pump control belt, electric fan and spark plugs.
5. Start engine and warm it up to normal running temperature, then remove again camshaft support covers. Working on one cylinder head at the time, proceed as follows: bring relevant camshaft in neutral position, loosen and then tighten again idler pulley lock nut thus giving the belt in its final tension load.

T: Tightening torque
 Idler pulley lock nut
 (warm engine)
 29 ÷ 35 N·m
 (3 ÷ 3.6 kg·m
 21.38 ÷ 25.8 ft·lb)

6. Fit back camshaft support covers and timing belts covers.

CHANGING ENGINE OIL AND REPLACING OIL FILTER

1. With engine warm, remove oil filler cap and oil pan drain plug letting oil drain completely into a suitable container (wait at least 15 minutes).

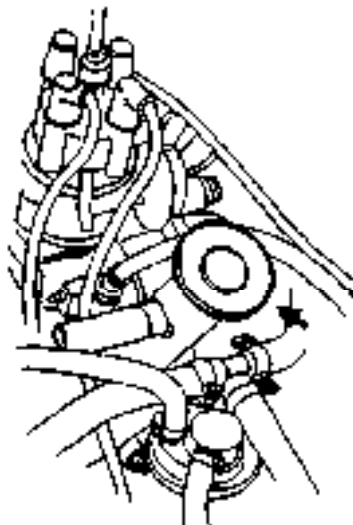

- A milky oil indicates the presence of cooling water. Identify the cause and take corrective measures.
- An oil with extremely low viscosity indicates dilution with petrol.

2. Using an oil filter wrench, remove oil filter.

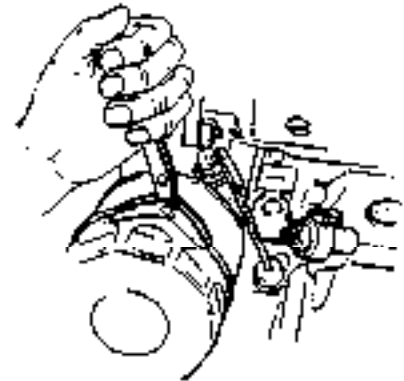

3. When engine oil is completely drained, clean oil pan drain plug and screw it back into place.

4. Moisten the gasket of the new oil filter and then install the filter tightening it all the way.

5. Refill engine with specified new oil referring to LUBRICANTS chart. Check oil level with dipstick.

ENGINE OIL QUANTITY

	kg	(lb)
Camshaft support sumps (*)	0.25	(0.55)
Engine oil sump	3.60	(7.94)
Sump capacity	3.15	(6.94)
Filter capacity	0.45	(1.00)

(*) Refill to be carried out, for each sump, in case of disassembly only.

6. Fit oil filler cap back and start the engine letting it idle for about 2 minutes.

7. Now check following items for any oil leaks: filter, pan, seal rings, oil pressure transmitter, gaskets of cylinder block and cylinder head covers, and cylinder head gaskets. If necessary, tighten or replace items that are not oil tight.

8. Turn the engine off and wait a few minutes.

9. Take out dipstick and clean it; fit dipstick back, take it out again and check oil level making sure it reaches the MAX reference mark.

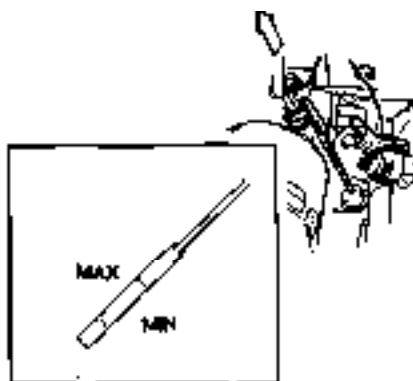

CAUTION:
When checking oil level, park the car on a level surface.

COOLING SYSTEM

System flushing

This operation should be performed only if plain water is used as engine coolant in summertime.

1. While engine is cold, remove radiator filler cap.
2. Loosen and remove drain plugs ①, located on bottom of cylinder block, let coolant drain completely and then fit plugs back on cylinder block bottom and tighten them.



1 Coolant drain plugs

3. Fill cooling system with recommended anti-incrustator following relevant instructions for use.

Recommended anti-incrustator:
NALCO 1006
INTERPROIND Jal Auto
Stand. No. 3681-69955

4. Remove again drain plugs from cylinder block bottom and let anti-incrustator drain completely.
5. Thoroughly flush the system with running water.
6. Fit drain plugs back to cylinder block and fill the radiator.

System refill

After having drained the cooling system, refill it with the kind and quantity of coolant as shown in the following chart.

Summertime			
Drinkable water		l	7.3
		(Imp Gal)	(1.61)
Wintertime			
Minimum outside temperature (°C)	-10	-20	-35
	(14)	(-4)	(-31)
Concentrated anti-freeze Std. No.			
368 1-69956 l	1.8	2.6	3.65
(Imp Gal)	(0.40)	(0.57)	(0.80)
Diluting drinkable water l	5.5	4.7	3.65
(Imp Gal)	(1.21)	(1.03)	(0.80)
Ready-to-use anti-freeze Std. No.			
3681-69958 l		7.3	
(Imp Gal)		(1.61)	

Refill radiator through relevant filler according to following instructions:

1. Refill the system till max. level mark in expansion reservoir is reached.
2. Start the engine and warm it up to normal running temperature thus allowing the thermostat to open and to expel any air that was left over in the system.
3. When engine is cold, top up cooling system till max. level mark in expansion reservoir is reached.
4. Fit filler cap back and tighten it.

Checking the system'

1. Check coolant level in radiator making sure it is within MAX and MIN level marks.
2. Check hoses and unions for leaks making sure they are not in any way damaged.
3. Check filler cap making sure relevant spring, gasket and valves are in good working condition.
4. Test the electric fan as follows:
 - (1) Disconnect thermostat wires and short-circuit them.
 - (2) Turn ignition key and check if electric fan-starts up.
5. Check radiator as per instructions contained in Group 07 - Radiator.
6. If top-up requires an abnormally large amount of coolant, check entire cooling system for leaks and eliminate them.

Radiator cap pressure test

1. Fit union ② onto tester and then insert it on expansion reservoir cap.
2. Apply pressure to the cap and check tester to make sure that when specified pressure reading is reached, the relief valve opens up.

Radiator filler cap relief pressure:
68.6 kPa (0.69 bar);
0.7 kg/cm²; 9.96 p.s.i.

CHECKING CYLINDER COMPRESSION

When diagnostic poor engine performance because power is not up to normal, it is advisable to test cylinder compression using relevant tester (MOTOMETER) and according to following procedure:

1. Start the engine and warm it up to normal running temperature.
2. Remove spark plugs.
3. Disconnect distributor's high voltage cable.
4. Apply compression tester onto the seat of one spark plug.

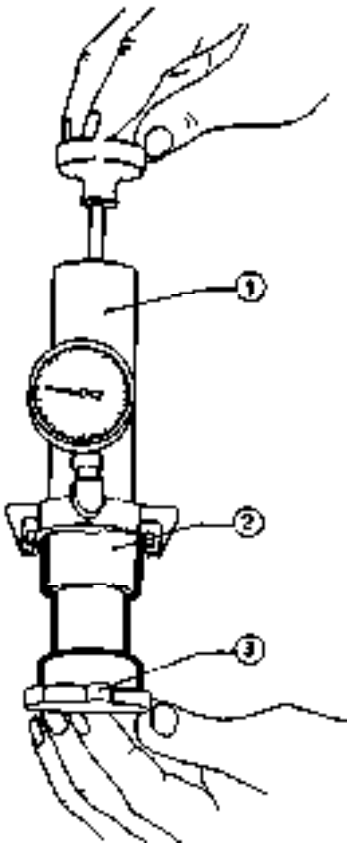

1 Tester
2 Union
3 Filler cap

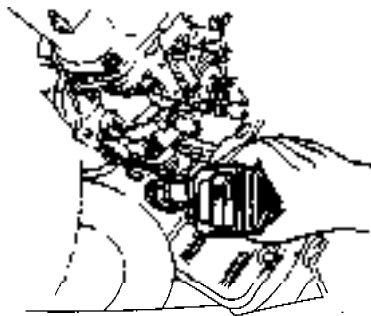

5. Crank the engine briefly keeping the accelerator pedal fully pressed so that carburetor throttle valve is fully open.
6. Verify that compression pressure is above min. value (make sure there are no leaks from tester's union).

Min. compression pressure
1030 kPa (10.3 bar;
10.5 kg/cm² ; 149.34 p.s.i.)

7. Repeat the test to check compression in other cylinders, being careful to reset the tester each time. Compare the readings and make sure that max. difference between the various cylinder pressure measurements does not exceed specified value.

Max. compression difference
between cylinders
98 kPa (0.98 bar;
1 kg/cm²; 14.22 p.s.i.)

If picked up values are not within specified ones, look for the trouble's cause in poor tightness of the valves

or between cylinder liners and pistons.

REPLACING AIR CLEANER CARTRIDGE

1. Unfasten air cleaner cover retaining spring clips (2).
 2. Lift cover (1) and remove cartridge.
 3. Thoroughly clean cartridge by blowing low pressure compressed air from within.
- If necessary, replace cartridge.

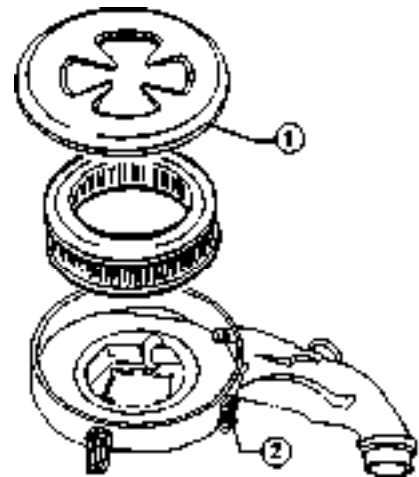

1 Cover
2 Air cleaner cover retaining spring clip

Cooling system pressure test

1. Remove expansion reservoir cap.
2. Tighten tester onto expansion reservoir filler.
3. Apply pressure to the cooling system and check tester to make sure that pressure remains within specified value.

Cooling system testing pressure:
107.9 kPa (1.08 bar;
1.1 kg/cm²; 15.65 p.s.i.)

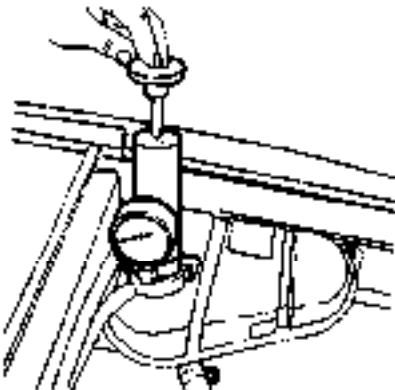

IGNITION AND FUEL SYSTEM

CHECKING AND REPLACING SPARK PLUGS

1. Disconnect spark plug wires with relevant protecting boots.
2. Remove spark plugs with spark plug wrench.
3. Clean electrodes and check insulation for cracks and chips. If electrodes are excessively worn, replace the spark plugs. Spark plug type: LODGE 25 HL.
4. When replacing spark plugs, coat plug thread with specified grease and then fit them in relevant seat tightening them according to specified torque.

Spark plug thread:
ISECO Grease: Molykote A - Std.
No. 4500 - 18304

Ⓢ: Tightening torque
Spark plugs
25 ÷ 34 N·m
(2.5 ÷ 3.5 kg·m
18.08 ÷ 25.31 ft·lb)

5. Connect spark plug wires and fit back relevant protecting boots according to following sequence: 1-3-2-4.

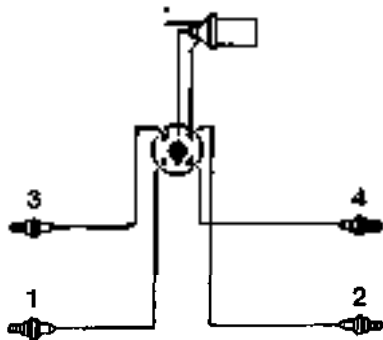

CHECKING IGNITION WIRING

1. Visually check ignition wiring for cracks, burns and loose terminals.
2. Measure resistance of high voltage cable by connecting an ohmmeter between the cable's terminal and the corresponding electrode on the ignition coil.

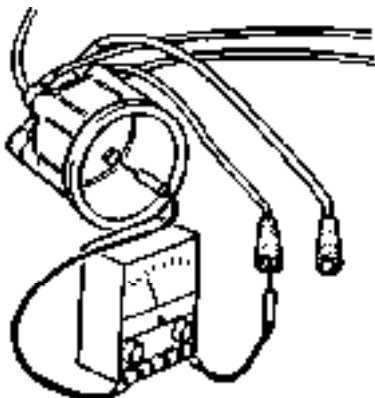

CHECKING THE DISTRIBUTOR

Visual check

1. Remove distributor cap and rotor ① and check them for cracks or chips.
2. Make sure that distributor cap carbon is securely kept in place in its seat by the relevant spring and that it moves freely thus ensuring proper constant adherence to distributor rotor.
3. Apply a coating of engine oil to felt inside rotor control shaft and a coating of specified grease to cam.

CHECKING CO%

CHECKING AND ADJUSTING IGNITION TIMING, IDLE-RPM AND CO%

1. Connect stroboscopic flash lamp feed clamps to the battery and the pickup to the high voltage cable of cylinder no. 1.
2. Connect an electronic tachometer to the engine by fitting feed clamps to the ignition coils feeding and the pickup to the coils high voltage cable.

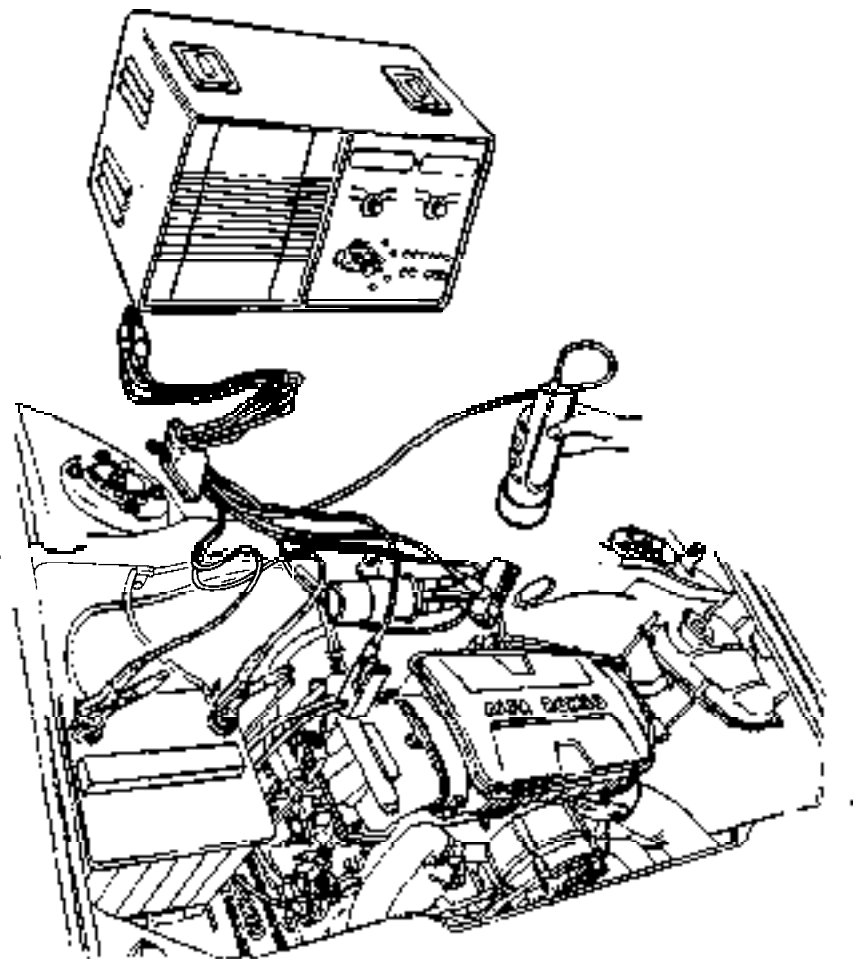

- Remove the small plastic cover located on the engine rear cover.

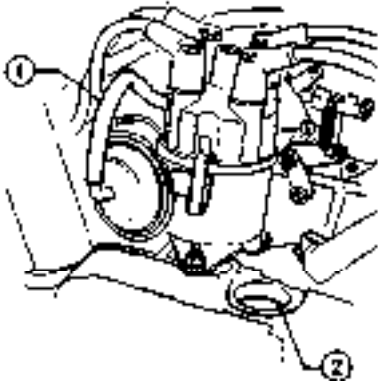

1 Advance hose
2 Ignition timing check hole

- Start the engine and warm it up to normal running temperature.
- Using the stroboscopic flash lamp, check if - with engine running at $\cong 900$ r.p.m. - the mark on the engine rear cover is in line with the fixed advance notch on flywheel.

Fixed advance
 $8^{\circ} \pm 1^{\circ}$

- Disconnect the vacuum advance hose from distributor and verify that when engine at 4500 r.p.m. the mark on the engine rear cover is in line with the max. advance notch on flywheel.

Max. advance
 $36^{\circ} \pm 1^{\circ}$

- If specified alignment does not take place, loosen the distributor retaining bolt and rotate distributor either clockwise to retard or anti-clockwise to advance.
- Tighten the distributor retaining bolt and check fixed and max. advance to make sure they are within specified values.
- Fit the small plastic cover back onto engine rear cover.
- Fit vacuum advance hose back onto distributor.

If above described adjustment does not succeed in correcting max. advance, overhaul or replace the distributor.

CHECKING AND ADJUSTING IDLE-RPM AND CO%

Preliminary inspection:

- Clean or replace air cleaner.
- Inspect ignition system making sure following parts are in good working condition: spark plugs, cables, distributor cap, rotor arm, (refer to: Group 05 - Ignition System).
- Check ignition timing.
- Check adjustment of accelerator control (see: Group 04 - Accelerator Control).

CAUTION:

If during engine tune up there is no extra cooling fan available, keep checking indicator pump and the water temperature gauge on dashboard and immediately suspend testing if temperature goes up, meaning that engine is overheating.

Check idle-rpm and overall CO% as follows:

- Insert CO-tester probe (2) into the tail pipe (1).
- Connect an electronic tachometer to the engine.

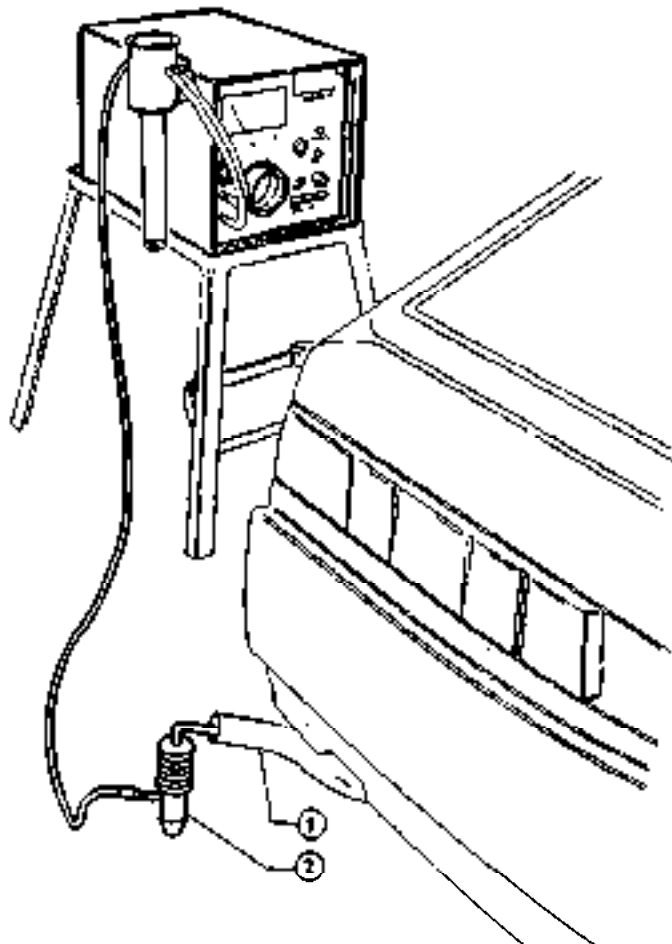

1 Tail pipe 2 CO-tester probe

COMPLETE CAR

3. Start the workshop's gas exhauster.
4. Start the engine and warm it up to normal running temperature.
5. Now check if engine rpm is within specified value.

Idle-rpm
 900 ÷ 1000 r.p.m.
 850 ÷ 950 r.p.m. (●)

(*) (for Switzerland, Sweden, Australia)

6. If not within specified value, adjust idle-rpm just by turning relevant idle-adjusting screw (2) which makes it possible to change rpm without changing CO percentage (Carbon monoxide).
7. Verify that CO percentage picked up by tester corresponds to specified value and that engine runs smoothly.

Allowed CO %
 < 3.5 % total

If not within specified value or in case of engine tune up after engine overhauling or after having cleaned or replaced the carburetor, an adjustment involving also mixture metering screw (1) and throttle valve screw (3) is required. In this instance, proceed as follows:

- (1) Remove seals from mixture metering screw (1) and from throttle valve screw (3).
- (2) Tighten idling screw (2) all the way.
- (3) Now act on throttle valve screw (3) and on mixture metering screw (1) till following conditions are present:

Rpm
 850
 800(*)
 CO %
 0.5 ÷ 1% total

(*) for Switzerland, Sweden, Australia

- (4) Loosen idling adjusting screw (2) till a 900 ÷ 1000 rpm (850 ÷ 950 rpm for Switzerland,

Sweden, Australia) idling speed is reached.

- (5) Act on mixture metering screw (1) till the smoothest possible engine running is obtained, while keeping CO% within the prescribed values.

CO%
 < 3.5% total
 0.7 ÷ 2.4%(*)

(*) for Switzerland, Sweden, Australia

- (6) Fit back into place mixture metering and throttle valve screw seals,
- (7) If further optimizing of idle-rpm is desired, just act on relevant idling adjusting screw (2).

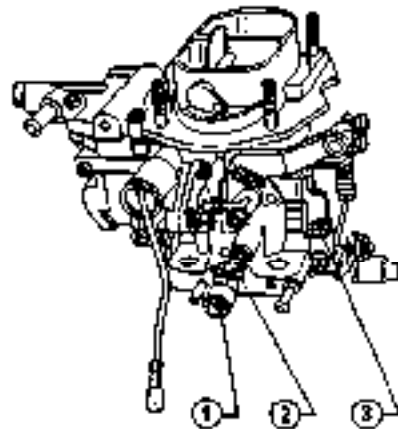

- 1 Idling mixture metering screw
- 2 Idling adjusting screw
- 3 Throttle valve adjusting screw

medium rpm, the vapors going up the oil filler go through the flame trap located in the hose (3) connecting oil filler to air cleaner; from here then they go through the min. rpm blow-by hose (5) and, downstream from throttle valve, are distributed onto intake manifold (7).

Since when the accelerator is fully depressed the vacuum generated by the engine is not sufficient to completely suck exhaust gases solely through the min. rpm hose, gases are also conveyed inside air cleaner, upstream from carburetor, by means of the max. rpm blow-by hose (2).

CHECKING HOSES AND UNIONS

1. Inspect hoses and unions to make sure they are not in any way damaged and that there are no leaks.
2. Disconnect all hoses and clean them blowing a jet of compressed air through them.

Replace any damaged hose.

3. Remove flame trap located in main blow-by hose near the oil filler; wash it with suitable cleaner, blow it with compressed air and, then fit it into place.

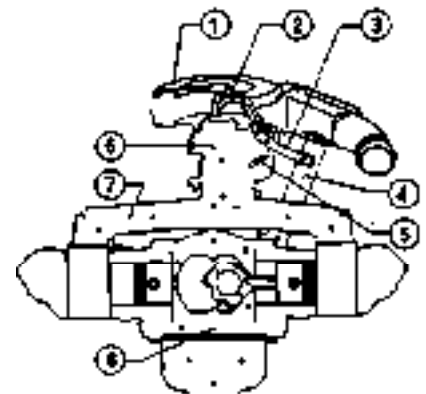

- 1 Air cleaner
- 2 Max. rpm blow-by hose
- 3 Main blow-by hose
- 4 Oil filter
- 5 Min. rpm blow-by hose
- 6 Carburetor
- 7 Intake manifold
- 8 Cylinder block

EMISSION CONTROL SYSTEM

Recycling of exhaust gas and oil vapors, generating in the cylinder block and then burned in the cylinders, is achieved through a series of blow-by hoses.

At any rpm, the vacuum created in the carburetor is sufficient to convey gas and vapors into intake duct and from here into cylinders for final combustion.

When engine is idling or running at

CLEANING CARBURETOR JETS

If necessary, clean carburetor jets and blow-by hoses as follows:

- a. Remove air cleaner, carburetor cover, and then remove main jets

as well as idle jets.

- b. Clean jets with compressed air (do not use any metal tool) and then fit them back onto carburetor; also fit cover and air cleaner.

REPLACING FUEL FILTER

Loosen hose clamps and remove the filter. Install a new filter paying special attention to the fuel flowing direction as indicated on filter body. Tighten hose clamps.

TROUBLE DIAGNOSIS AND CORRECTIONS

Condition	Probable cause	Corrective action
CANNOT CRANK ENGINE OR SLOW CRANKING	• Dead battery	Recharge and check recharge system
	• Faulty battery	Replace
	• Oxidized battery terminals	Clean terminals
	• Loose wiring connections in starting circuit	Correct
	• Faulty starter switch	Replace
	• Faulty starter	Repair or replace

(Starting circuit trouble-shooting procedure)

Turn on starter while lights are on (set switch to "ON").

If lights go off or dim considerably:

- a. Check battery
- b. Clean battery terminals

If lights stay bright and starter does not work:

- a. Check wiring connection between battery and starter
- b. Check starter switch
- c. Check starter

ENGINE CRANKS NORMALLY BUT WILL NOT START

In most cases the trouble lies either in the ignition system or in the fuel system.

- Trouble in ignition system
- Trouble in fuel system
- Valves do not work properly
- Low compression

(Trouble-shooting procedure)

First of all check spark plugs as follows:

Disconnect high voltage cable from one spark plug and hold it about 10 mm (0.39 in) from any engine metal part and let the starter run.

CAUTION

Above test must be performed with uttermost care.

DRIVE UNIT REMOVAL AND INSTALLATION

REMOVAL

Drive unit supports

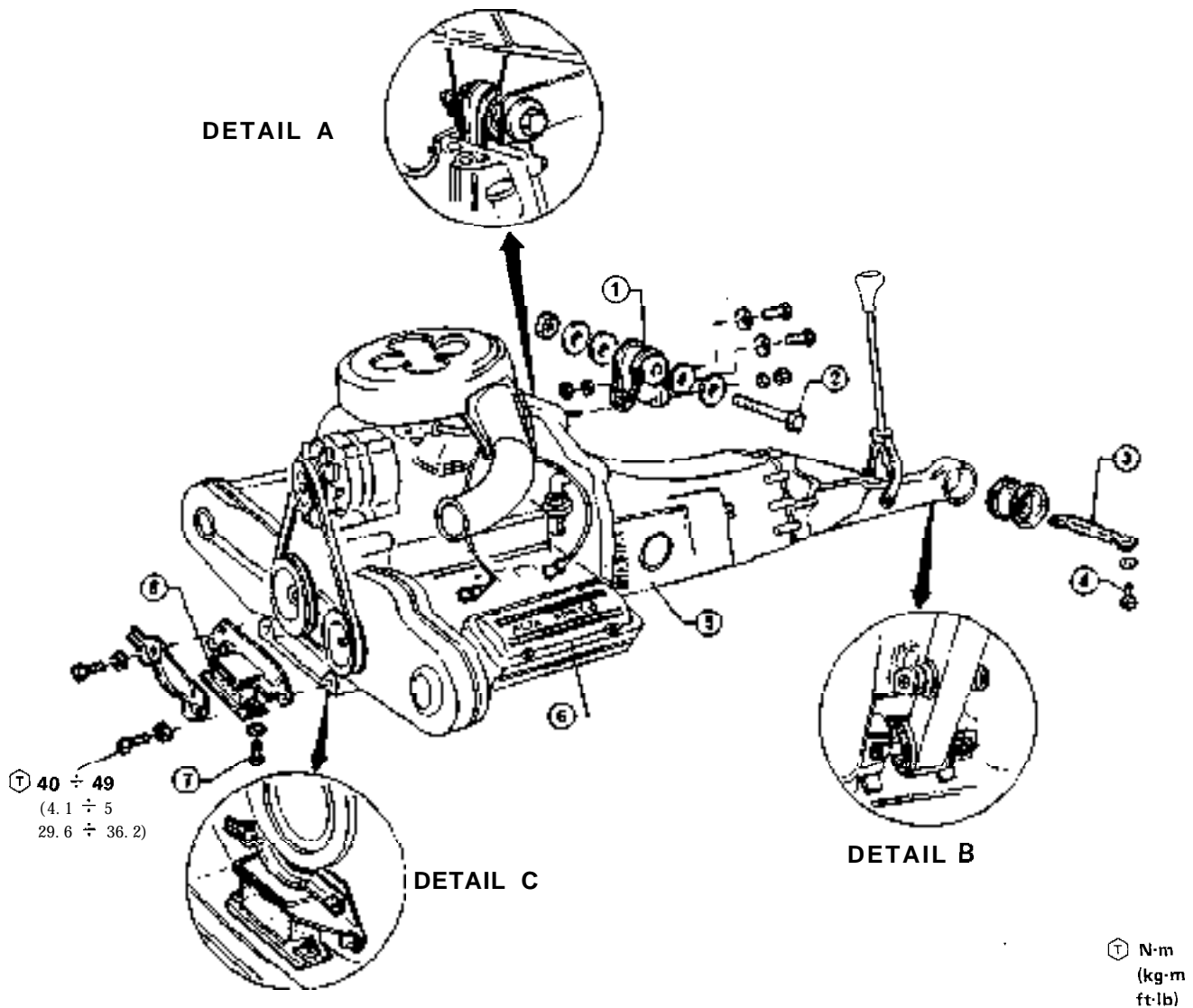

- 1 Drive unit central support
- 2 Central support to body fixing bolt
- 3 Rear support pin
- 4 Rear support to body fixing screws
- 5 Gearbox casing
- 6 Engine unit
- 7 Engine front support to crossmember fixing screw
- 8 Engine front support

Detail A Central support
 Detail B Rear support
 Detail C Front support

ENGINE MAIN MECHANICAL UNIT

Engine compartment - **Electric wires disconnections**

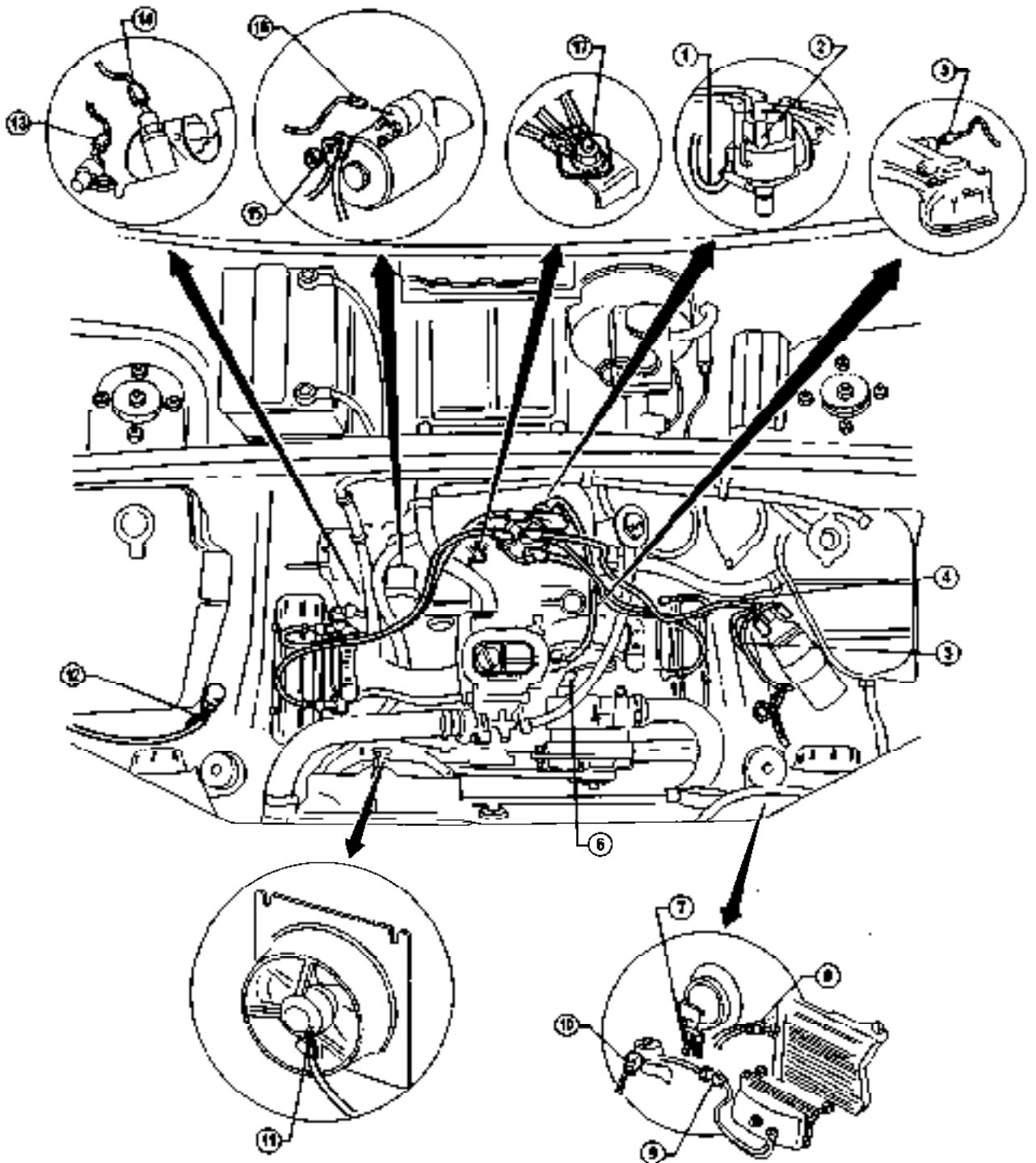

- | | |
|--------------------------------------------------------|---------------------------------------------------|
| 1 Ignition inductor cable | 10 Horn cables |
| 2 ignition distributor | 11 Electric fan supply cable |
| 3 Cooling temperature transmitter cable | 12 Windshield and rear window washers pump cables |
| 4 Coil high voltage cable | 13 Water temperature thermal contact cable |
| 5 Tachometer and coil low voltage cables | 14 Oil pressure manual contact cable |
| 6 Alternator and alternator warning light supply cable | 15 Starter supply cables |
| 7 Head lamps cables | 16 Energization cable |
| 8 Electric fan thermal switch cables | 17 Earth cable on engine cover |
| 9 Foglamps cables | |

ENGINE MAIN MECHANICAL UNIT

Engine compartment - **Piping** release

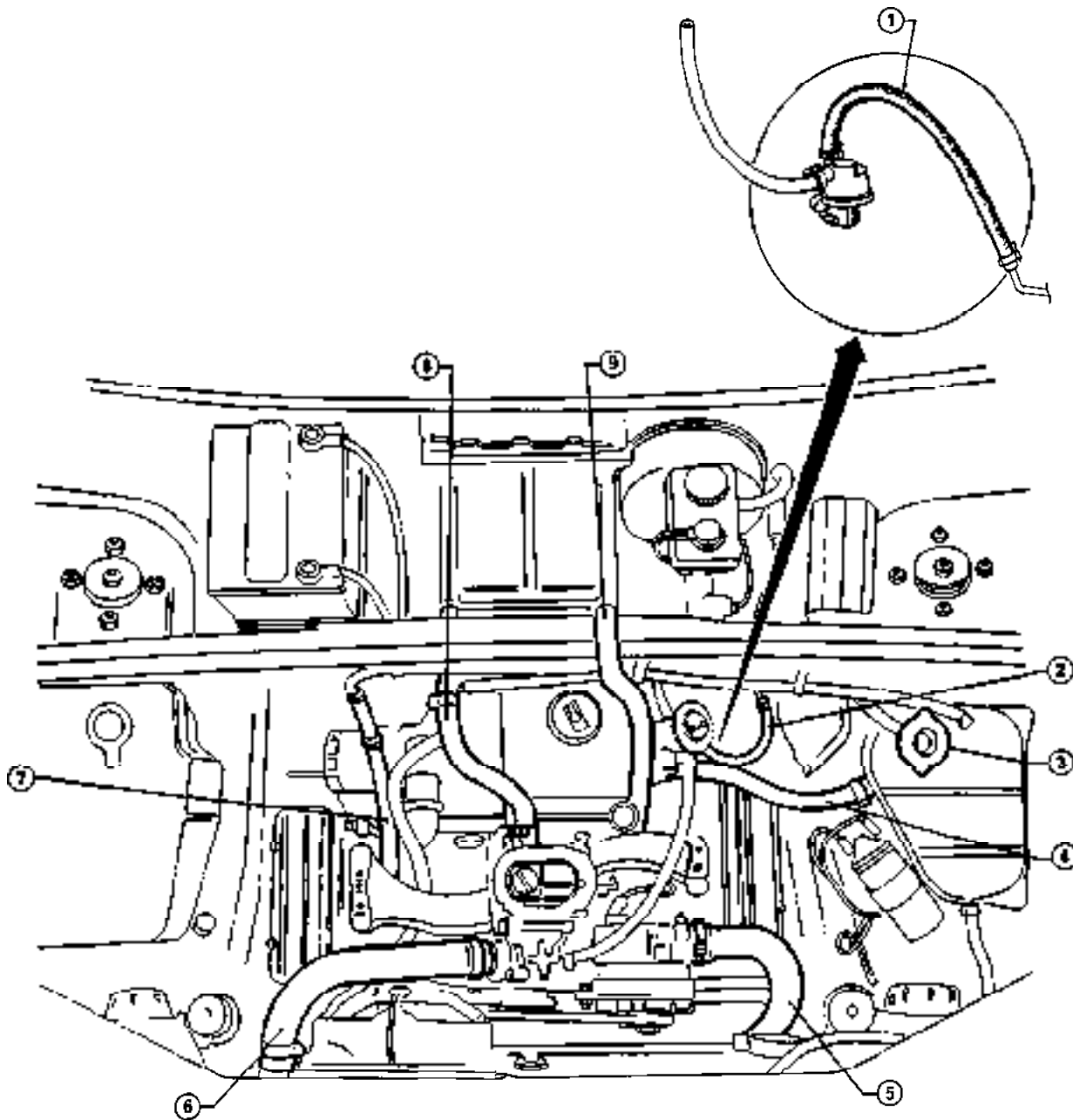

- 1 Fuel pipe
- 2 Clutch oil supply pipe
- 3 Expansion tank plug
- 4 Air bleeder into crankcase
- 5 Sleeve for water return from radiator
- 6 Sleeve for water delivery to radiator
- 7 Servobrake vacuum pipe
- 8 Hot water to heater supply pipe
- 9 Heater water return pipe

During engine removal from car, it is necessary to remove engine and gearbox - differential as single unit.

Put the vehicle on the auto lift and engage first gear.

WARNING:

Great care is required when dealing with a hot engine.

1. Operating from passenger compartment inside withdraw knob of gearbox lever, then remove the two lever bellows.

2. Remove the hood (refer to: Group 56 - Hoods).

3. Working from inside the engine compartment, disconnect the battery earth cable.

4. Disassemble the air filter as follows:

(1) Disconnect the corrugated air intake pipes from the air filter by taking off the fixing clamps.

(2) Disconnect the blow-by pipes. Then remove the filter (Refer to: Group 04 Air Filter - Removal).

5. Disconnect accelerator and starter controls as follows:

(1) Extract the retaining ring (5), slip the return spring (4) off its clamps and take off the slotted adjuster (6) from the throttle control lever.

(2) Release accelerator cable together with bracket (1) unscrewing the two securing screws located on intake manifold.

(3) Disconnect hose and sheath of starter control of operating on sheath securing screw (2) and on starter control lever screw (3).

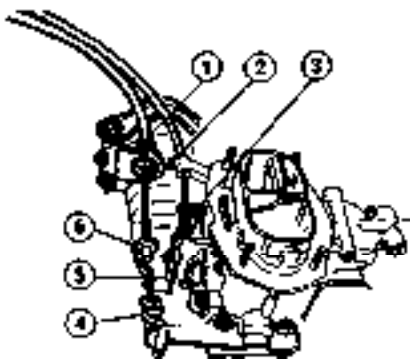

- 1 Bracket
- 2 screw
- 3 Screw
- 4 Spring
- 5 Retaining ring
- 6 Adjuster

6. With reference to the figure on page 01-3 disconnect the following electric cables, preferably as indicated :

- earth cable (17), from the engine rear cover
- high voltage cable (4), from the coil
- low voltage and tachometer cables (5) from coil
- alternator and warning light supply cable (6), from the alternator
- water temperature thermal contact cable (8), from the thermal contact on the right hand head electric fan supply cable (11), from the fan
- windshield and rear window washers pump cables (12) from the pump
- starter motor supply (15) and energization (16) cables from the starter motor
- oil pressure switch cable (14), from manual contact on the rear cover
- electric fan thermal contact cable (8), from the thermal contact on radiator
- fog lamp supply cables (9), from fog lamp connectors
- head lamp supply cables (7), from the headlamps
- horn supply cables (10), from the horns
- water temperature transmitter cable (3), from the transmitter on the intake manifold
- electronic ignition inductor cable (1), from distributor
- remove ignition distributor cap (2) together with spark plug cables
- oil level sensor cable, from level rod (for models fitted with check control, only)

CAUTION:

Unfix the electrical cables from their clamps, separate them from the drive unit so as not to impede its removal.

7. Unscrew and remove the coolant expansion tank plug.

8. Raise the car and from beneath remove the right hand drain plug (3) and then the left hand drain plug (4) under the cylinder block and drain off the coolant; screw the plugs again

after draining.

9. Depending on what is to be done, drain the oil from the oil sump by removing the plug (2) and, if necessary, drain the oil from the gearbox by removing the drain plug (1). Screw the plugs again after draining.

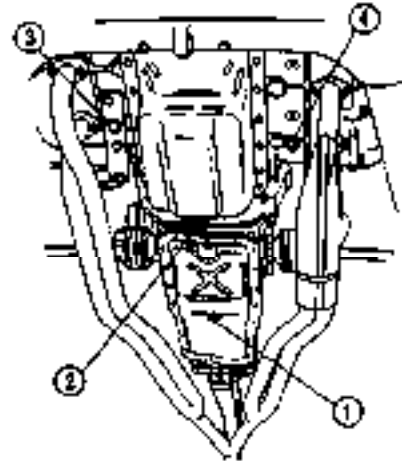

- 1 Gearbox oil drain plug
- 2 Engine oil drain plug
- 3 Right head coolant drain plug
- 4 Left head coolant drain Plug

10. Lower the vehicle and with reference to figure of page 01-4, disconnect the following pipes and couplings, preferably as indicated:

- hot water to heater delivery pipe (8), from the supply manifold
- water from heater return pipe (9), from the water pump intake
- delivery pipe (4) to block from the water pump intake
- water delivery coupling (6), to radiator
- radiator water return coupling (5), from the water pump intake
- fuel inlet line (1), from supply pump
- clutch oil delivery hose (2), from pipe union (properly plug the hose)
- servobrake vacuum intake pipe (7), from the suction manifold.

11. Loosen bolt (1) securing engine central support (2) to body.

INSTALLATION

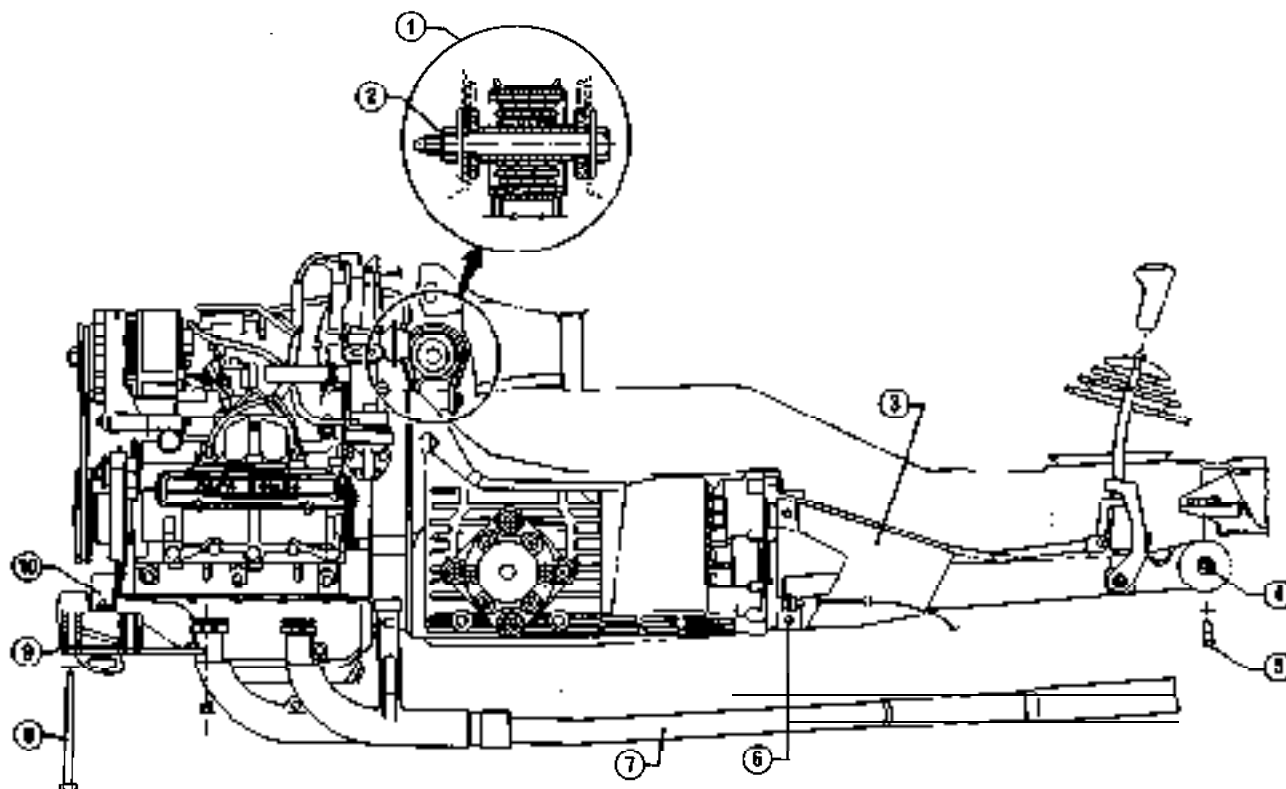

- | | |
|---------------------------------|--------------------------------------|
| 1 Central support | 6 Bolt securing gearbox rear support |
| 2 Central support securing bolt | 7 Exhaust pipe |
| 3 Rear support | 8 Engine cross member securing screw |
| 4 Pin | 9 Engine support cross member |
| 5 Rear support securing screw | 10 Front elastic support |

CAUTION:

Drive unit assembly must be performed in such a way that the gearbox rear support and the engine front support are not respectively upwards and longitudinally pre-loaded.

Referring to preceding illustration, follow as indicated.

1. Raise the drive unit with the column lifter used for disassembly until the centre support axis (1) is at about the halfway point of the body slot and tighten the relevant bolt-@.

Connect the left strut to the engine support cross member and fasten the cross member in position to the body with the screws (8).

2. Fasten the front support (10) in position to the cross member tightening the correct screws.

3. Remove the lifter and unloose the lower bolt (6) securing the gearbox to the rear support.

4. Put the rod (4) in the rear support (3), positioning it on its body clamping points and screw up the screws (5).

5. Screw up the drive shafts to differential shafts joint screws in oil with the prescribed torque.

ⓧ: Tightening torque
 Drive shafts to differential shafts connection screws
 33 ÷ 36 N-m
 (3.4 ÷ 3.7 kg-m
 24.58 ÷ 26.75 ft-lb)

6. Assemble the exhaust pipe (7).

7. Clamp the lower bolt (6) securing the rear support to the gearbox.

8. With reference to the following

illustration put the side rod (4) in the support (3) on the right side rail (2) then tighten, first, screw (6), second, screw (5).

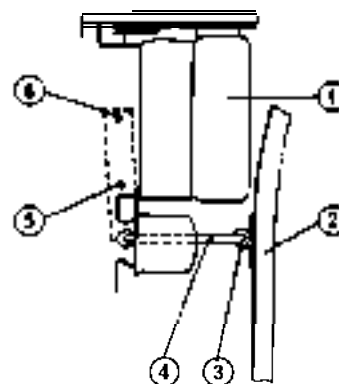

- | | |
|-----------------------|------------|
| 1 Right cylinder head | 4 Side rod |
| 2 Right side rail | 5 Screw |
| 3 Support | 6 Screw |

ENGINE MAIN MECHANICAL UNIT

9. Complete the unit assemble carrying out the disassembly operations in reverse order, with particular attention to the following steps.
 (1) By means of a spanner, tighten to the prescribed indicative torque, the union connecting hose to clutch control pipe.

T: Tightening indicative torque relevant to hose union to pipe.
 $15 \div 19 \text{ N}\cdot\text{m}$
 $(1.5 \div 1.9 \text{ kg}\cdot\text{m})$
 $10.84 \div 13.78 \text{ ft}\cdot\text{lb}$

(2) Check the engine oil level corresponds to the MAX mark on the dipstick, and the gearbox oil level reaches the lower edge of the filler hole. If necessary, top up with the

prescribed oil:

Engine oil
 AGIP Sint 2000 10W50
 IP Super Motor Oil 10W50

Gearbox oil differential:
 AGIP F1 Rotra HP SAE 80W90
 IP Pontiac HD 80W90

(3) Bleed the clutch hydraulic system (See Unit 12 - Hydraulic System Bleeding) and if necessary top up the oil level to the MAX mark on the tank with the prescribed fluid (AGIP F1 Brake Fluid Super HD or IP Auto Fluid FR).

(4) Top up the coolant with the prescribed liquid.

Summer
 Potable water

Winter
 Antifreeze (See Unit 07 - General Directives)

(5) Adjust the accelerator cable (See Unit 04 Accelerator Wire Adjustment).

(6) With the engine at running heat, check its idling. For any tuning up required, see Unit 00 Engine Maintenance - Ignition and Feed System.

SEPARATION AND ASSEMBLY OF THE UNITS

SEPARATION

With the drive unit on the rotatory stand fitted with suitable supporting equipment, separate the engine unit from the gearbox unit for the purpose of replacement or overhaul of the two units and of the clutch, as follows:

1. Unscrew and take off the nuts and washers **1** from the starter motor **3** securing screws **2** and remove the starter motor from the engine unit.

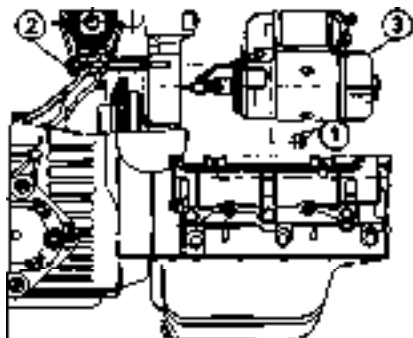

1 Nut and washer 3 Starter motor
 2 Screw

2. Remove the lower cover **1** protecting the engine flywheel after disassembling the screws and washers **2** securing the lower cover to the engine rear cover and to the gearbox.
 3. Unscrew and remove the remaining nuts and washers **3** and complete the separation of the two units.

Withdraw the thrust bearing from its support on the gearbox so as not to damage it.

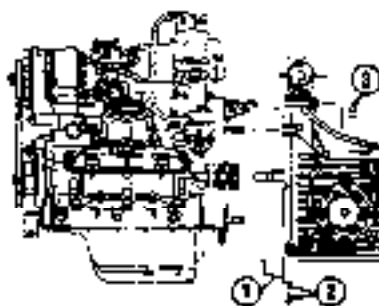

1 Lower cover 3 Nut and washer
 2 Screw and washer

ASSEMBLY

1. Lubricate the direct drive shaft working seat with the prescribed grease (Grease Molykote paste G).
 2. Perform assembly operations in the reverse order to the separation, tightening connecting nuts and bolts to the prescribed torque.

T: Tightening torque
 Nuts and bolts connecting the two units
 $39 \div 48 \text{ N}\cdot\text{m}$
 $(4 \div 4.9 \text{ kg}\cdot\text{m})$
 $28.92 \div 35.43 \text{ ft}\cdot\text{lb}$

ENGINE DISASSEMBLY

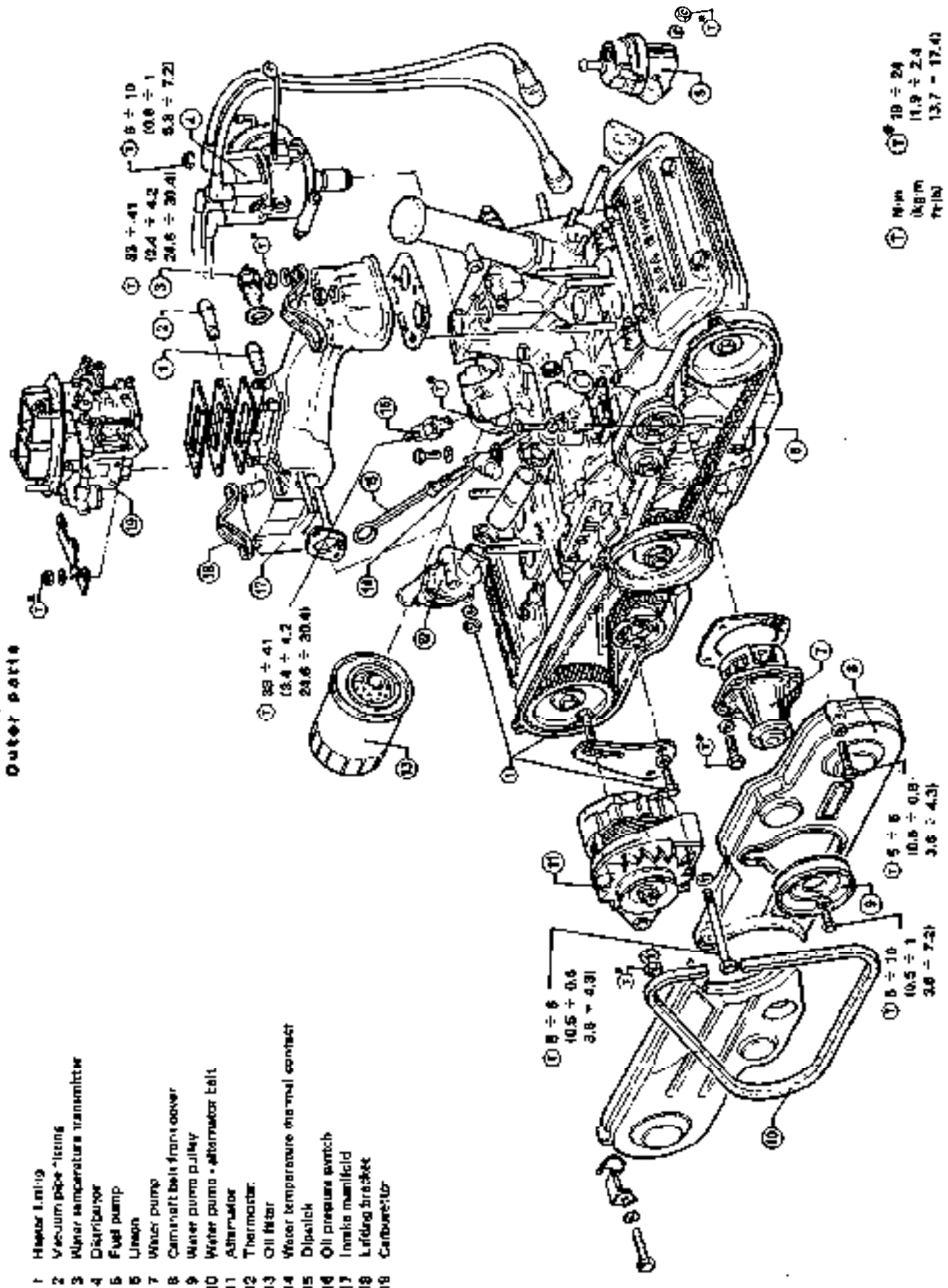

ENGINE MAIN MECHANICAL UNIT

Internal parts

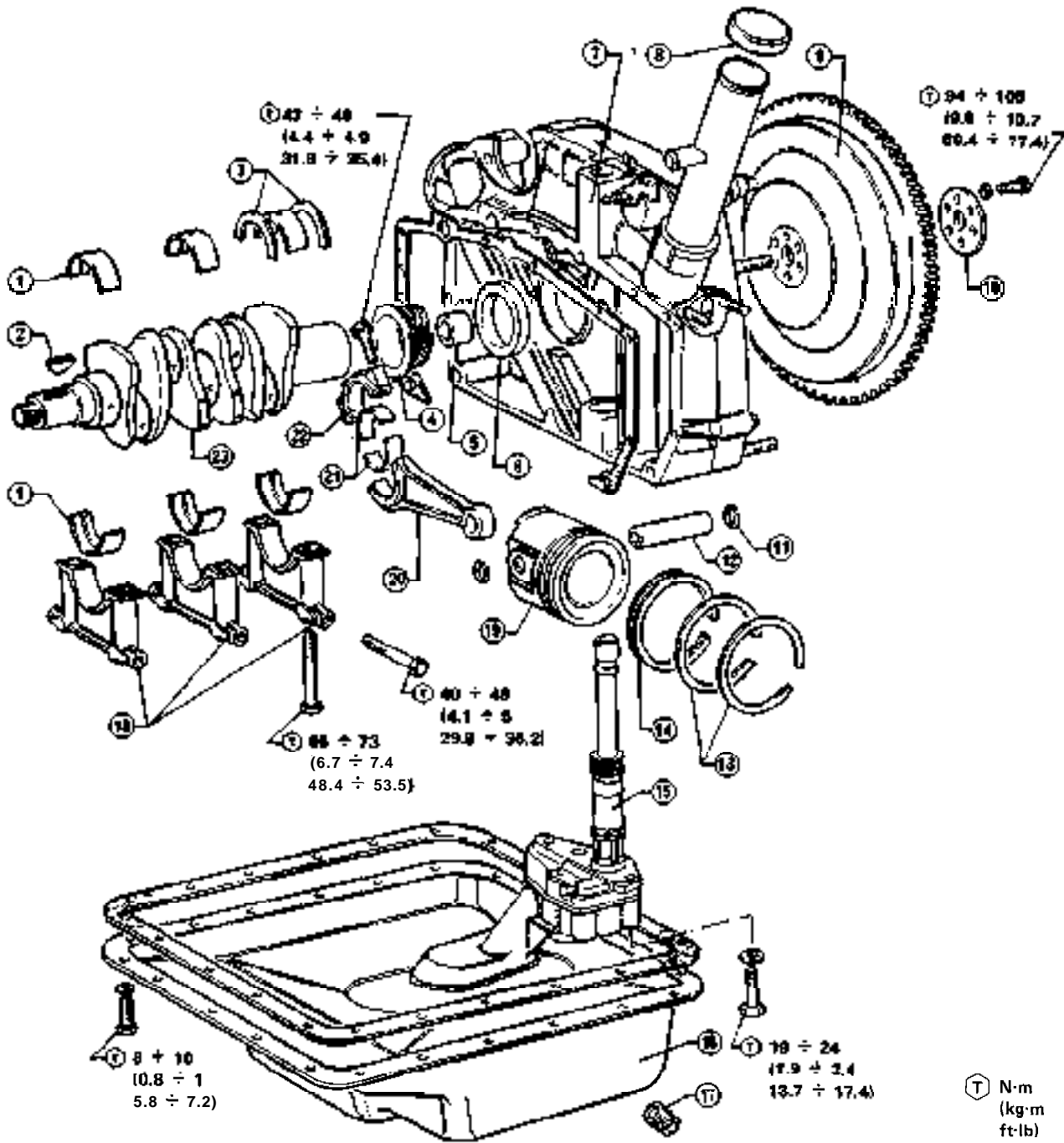

- | | | | |
|----|------------------|----|-------------------------|
| 1 | Main bearings | 13 | Compression rings |
| 2 | Woodroff key | 14 | Oil scraper ring |
| 3 | Thrust half-ring | 15 | Oil pump |
| 4 | Oil pump gear | 16 | Oil sump |
| 5 | Bush | 17 | Engine oil drain plug |
| 6 | Seal ring | 18 | Main bearing caps |
| 7 | Rear cover | 19 | Piston |
| 8 | Oil plug | 20 | Connecting rod |
| 9 | Flywheel | 21 | Connecting rod bearings |
| 10 | Washer | 22 | Connecting rod cap |
| 11 | Lock ring | 23 | Crankshaft |
| 12 | Fin | | |

(T) N·m
(kg·m
ft·lb)

ENGINE MAIN MECHANICAL UNIT

PRELIMINARIES

1. Remove drive unit from car according to procedures: Drive Unit Removal and Installation.
2. Remove gearbox unit and clutch unit from engine according to procedures: Separation and Assembly of the units.

ENGINE UNIT

1. Sequentially remove following parts:

- Oil filter ① using proper spanner
- Dipstick ③.
- Pressure switch ② for minimum oil pressure check
- Thermal contact ④ for water temperature check from right cylinder head.

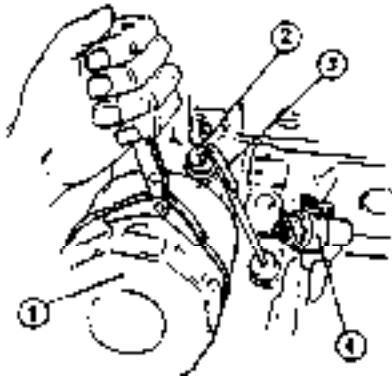

1 Oil filter 3 Dipstick
2 Pressure switch 4 Thermal contact

2. Remove sparking plugs using proper box spanner.

3. Remove distributor assembly.
 - (1) Disconnect vacuum advance pipe ① from carburettor.
 - (2) Loosen distributor securing nut ② and withdraw distributor from rear cover.

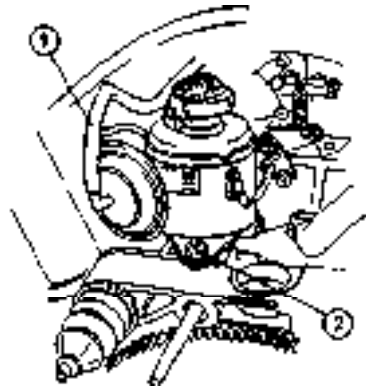

1 Vacuum advance pipe
2 Distributor securing nut

4. Remove alternator.
 - (1) Loosen securing bolts ① fixing alternator ② and remove driving belt.
 - (2) Complete bolts ① removal and take out alternator ②.
 - (3) Unscrews screws ③ and remove bracket ④.

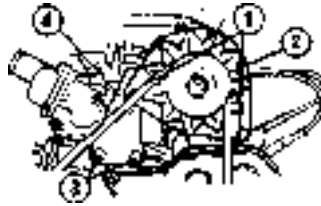

1 Bolts 3 Screws
2 Alternator 4 Bracket

5. Remove pipings.
 - (1) Loosen screws of clamps and remove fuel supply pipe ①.
 - (2) Loosen screws ③ of water system coupling ③ clamp ② and remove coupling.

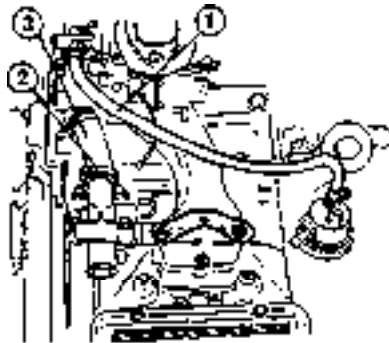

1 Fuel pipe 3 Coupling
2 Clamp

6. Unscrew and remove screws ② fixing union ① to block, then remove the union.

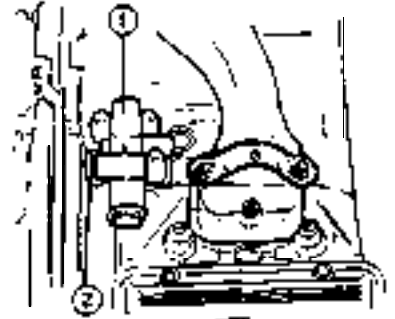

1 Pipe union 2 Screws

7. Remove carburettor
 - (1) Unscrew the four nuts with securing washers carburettor to intake manifold.
 - (2) Remove the accelerator cable return spring securing bracket, carburettor, relevant gaskets and spacer.

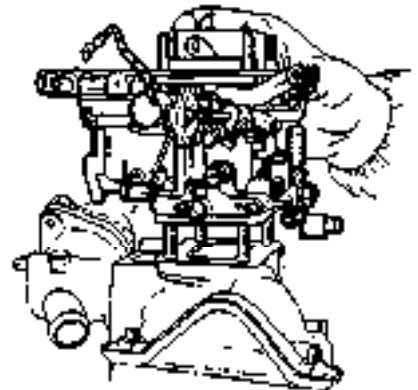

8. Remove thermostat
 - (1) Unscrew screws ③, remove cover ⑤ and thermostat.
 - (2) Unscrew nuts 2 and remove thermostat housing 1 from intake manifold ④.

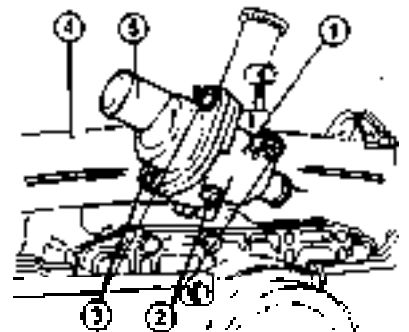

1 Thermostat housing 3 Screws
2 Nuts 4 Intake manifold
5 Cover

9. Remove intake manifold

- (1) Unscrew nuts (3), remove engine lifting bracket (2) and manifold (1).
 (2) Remove water temperature transmitter from intake manifold.

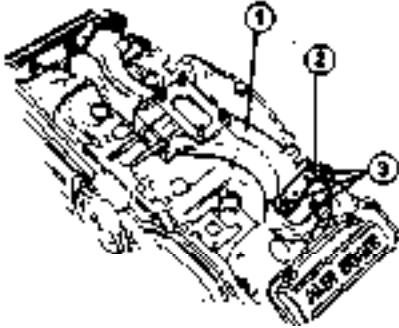

1 Intake manifold 3 Nuts
 2 Bracket

10. Remove fuel pump assembly

- (1) Unscrew nuts with washers securing fuel pump to block rear cover (4).
 (2) Remove pump (3), spacer (2) and pump control push rod (1).

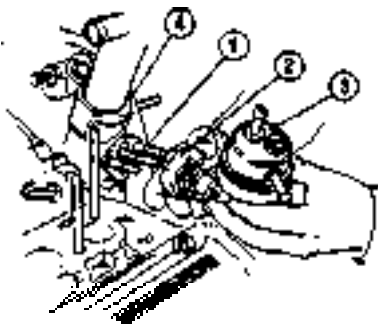

1 Push rod 3 Pump
 2 Spacer 4 Cover

11. Remove camshaft driving toothed belts.

- (1) Loosen securing screws and remove two camshaft driving front belts guards.

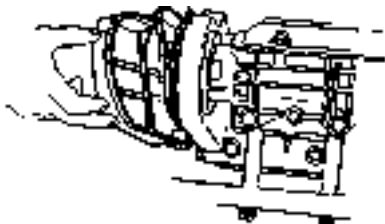

- (2) Unscrew right belt stretcher (2) securing nut and press on jockey pulley (1) to overcome belts tension load; lock nut by fixing belt stretcher in the "loose belt" position.

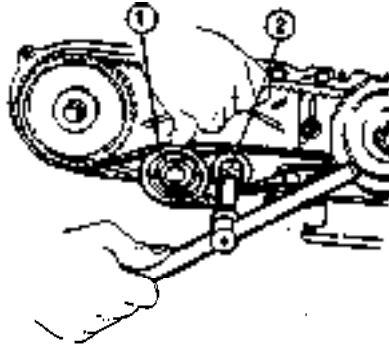

1 Jockey pulley 2 Belt stretcher

- (3) Withdraw belt from pulley on camshaft and on driving shaft, respectively.

- (4) Repeat procedure for left head camshaft driving belt.

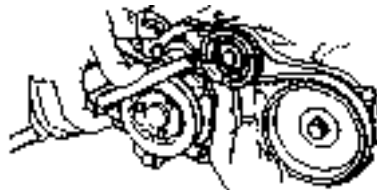

12. Unscrew screws securing pulleys to camshafts preventing their rotation by toothed spanner A.5.0195, then remove pulleys.

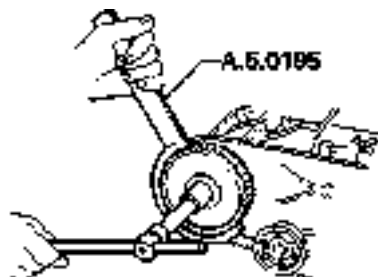

13. Unscrew securing nut and remove right belt stretcher (1) and spring (2).

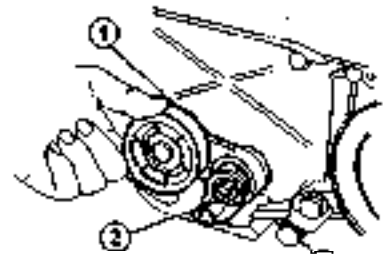

1 Belt stretcher 2 Spring

14. Remove camshaft driving belts rear covers.

15. Remove water pump assembly. (1) Unscrew screws 1 with washers securing pulley 2 to water pump hub and remove pump driving pulley.

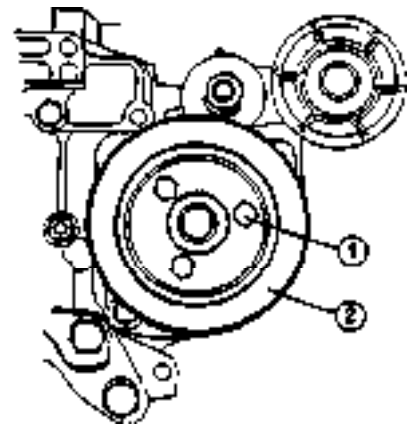

1 Screws 2 Pulley

- (2) Unscrew screws (2) securing water pump (3) to block and remove pump with gasket.

16. Unscrew nut (1) and remove right jockey pulley.

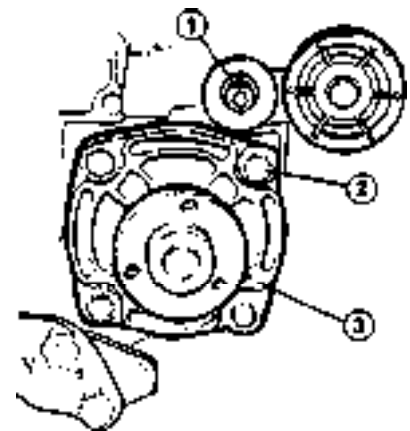

1 Nut 3 Water pump
 2 screws

ENGINE MAIN MECHANICAL UNIT

17. Lock flywheel by tool A.2.0378.
 18. Unscrew screws ① and ③, remove guard and engine front support ④.

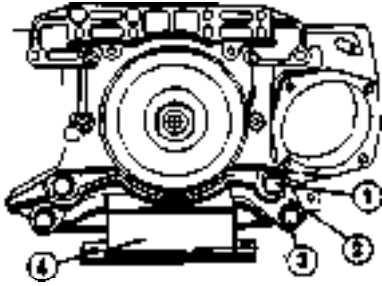

1 Screw 3 Screw
 2 Guard 4 Front support

19. Remove pulleys from crankshaft.
 (1) Unscrew nut ①.
 (2) Sequentially remove washer ② and spacer ③, water pump and alternator driving pulley ④, right head camshaft drive toothed pulley ⑤, spacer ⑥, left head camshaft drive toothed pulley ⑦ and pilot belt washer ⑧.

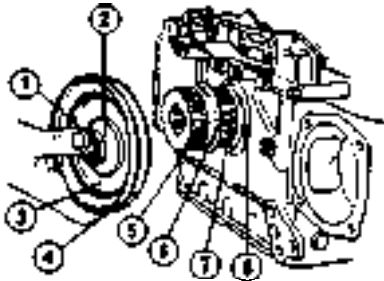

1 Nut 5 Toothed pulley
 2 Washer 6 Spacer
 3 Spacer 7 Toothed pulley
 4 Pulley 8 Washer

20. Remove flywheel locking tool, previously fitted.
 21. Remove cylinder heads.
 (1) Unscrew screws ① fixing covers ② to camshaft supports; remove covers with relevant gaskets.

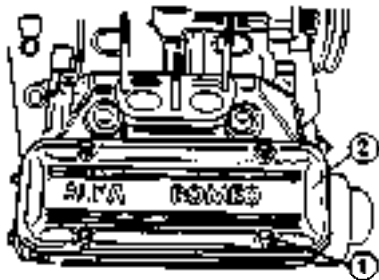

1 Screws 2 Cover

- (2) Suck oil from camshaft supports tanks with a suitable syringe.
 (3) Unscrew screws ① and ② securing cylinder heads to block; remove heads with relevant gaskets.

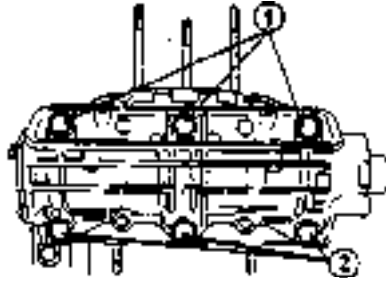

1 Screws 2 Screws

22. Remove oil sump.
 (1) Unscrew screws with washers ① securing oil sump to block.
 (2) Remove oil sump and relevant seal gasket.
 (3) If required remove sealant marks on sump and block.

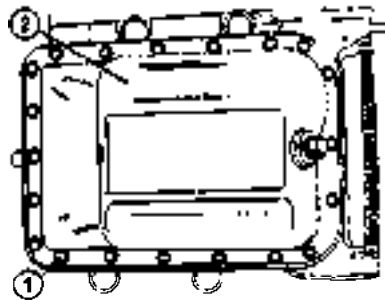

1 Screws 2 Oil sump

23. Remove oil sump assembly.
 (1) Unscrew screws with washers ① securing oil pump ② to block rear cover.

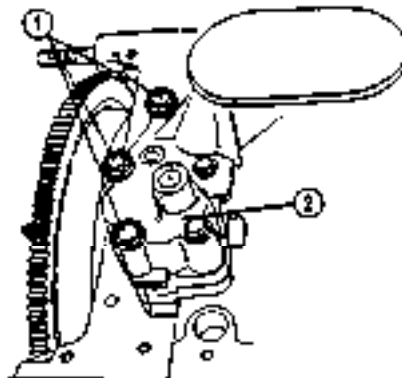

1 Screws 2 Oil pump

- (2) Withdraw upward pump from block.

24. Remove block front cover.
 (1) Unscrew screws ① and nuts with washers ② securing cover ③ and remove cover with relevant gasket.
 (2) Remove front oil retaining ring ④ from cover by lever with a screwdriver.
 Replace ring at assembly.

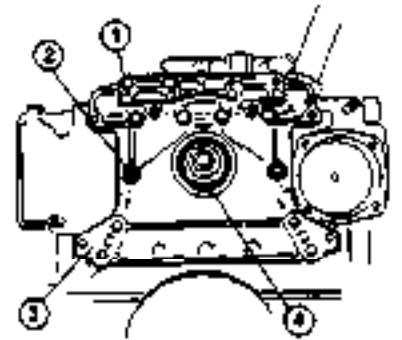

1 Screws 3 Block front cover
 2 Nuts 4 Oil retaining ring

25. Remove pistons and connecting rods.
 (1) Fit to flywheel a tool which allows crankshaft rotation.

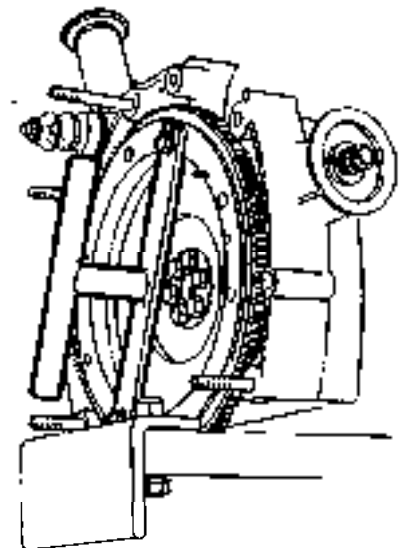

- (2) Turn crankshaft to permit access to screws securing connecting rod caps.
 (3) Unscrew and remove screws ② and connecting rod caps ①.

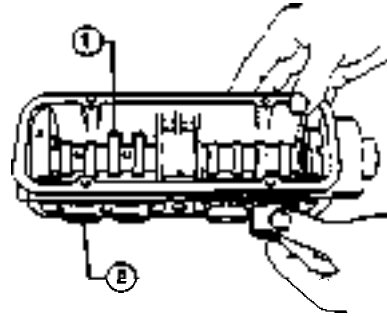

1 Camshaft 2 cups

5. Withdraw front oil retaining ring from its seat on camshaft support using a screwdriver.

8. Acting on lever A.3.0324 compress springs and withdraw valve stem cotters using a screwdriver.
 9. Sequentially remove upper caps, outer and inner springs, boots from intake valves, washers and lower cups.
 10. Repeat removal procedure for each valve.

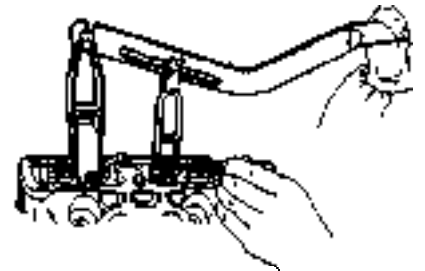

11. Withdraw yoke from head support tool and take out valves from head lower side.

CYLINDER HEADS

1. Secure head to support stand A.2.0195 connected to fork A.2.0226 previously clamped in a vice,
 2. Unscrew screws 2 securing camshaft rear cover 3 to support ①; remove cover with seal gasket.
 3. Loosen and remove screws ④ with washers fixing camshaft support to cylinder head; remove support with relevant gasket.

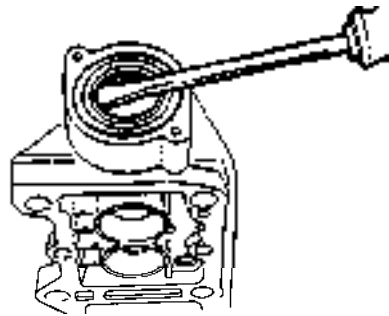

6. Fit tools A.3.0321, A.3.0324 and A.3.0103/6, used for valves removal, to head.
 7. If not already done, insert valves retaining yoke ① into cylinder head support tool A.2.0195.

CRANKSHAFT

1. Clamp cranksaht in vice.
 2. Secure puller A.3.0402 to shaft and withdraw rear guide bushing from crankshaft.

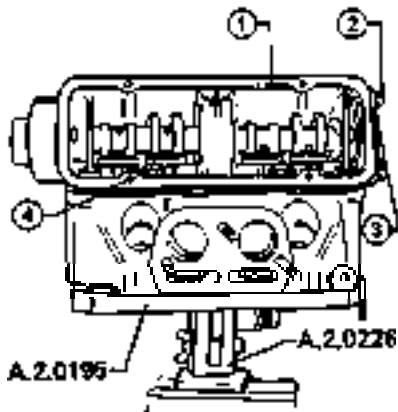

1 Support 3 Cover
 2 Screws 4 Screws

4. Remove cups ② from housing on support, then camshaft ① withdrawing from rear side.

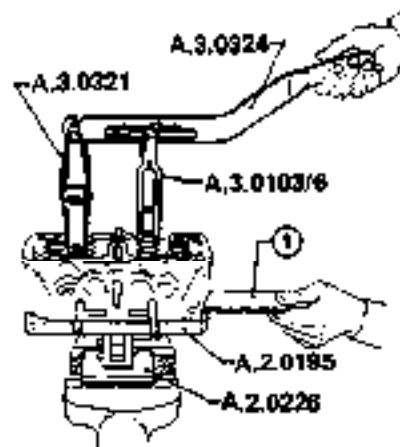

1 Yoke

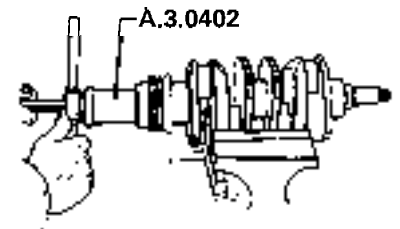

3. Withdraw oil pump and distributor control gear by using proper plate and press.

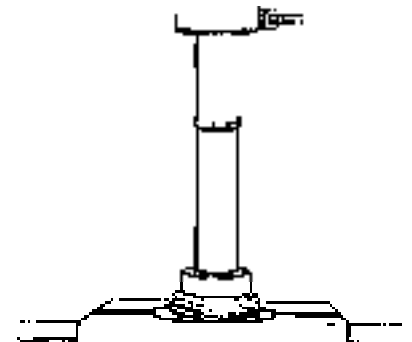

grinding, in order to ensure exact guide/seat perpendicularity as well as proper valve working position.

VALVE SEATS

1. Check valve seats for any scores, cracks or burrs and make sure they are properly fitted in their respective recess on the cylinder head.
2. If necessary, mount the head on tool A.2.0226 and regrind the valve seats using the proper tool.

This operation may be performed as long as there is sufficient grinding allowance that will permit eliminating the existing flaws while keeping the specified profile; contrarywise, valve seats will have to be replaced. For relevant procedure see paragraph: "Valve Seat Replacement".

(1) Regrind valve contact face till all evidence of wear has been removed and following taper is obtained :

$$\beta = 90^\circ \div 90^\circ 30'$$

of dimension "a" on the "Ø" reference diameter.

Ø Reference diameter:

Intake = 37.3 mm (1.4685 in)

Exhaust = 31.9 mm (1.2559 in)

"a" dimension at max. regrinding limit:

2.9 mm (0.1142 in)

(2) Machine the valve seat upper face still the Ø reference diameter position obtained through the previous operation is reached, attaining the specified α taper.

Taper of valve seat upper face
 $\alpha = 120^\circ$

(3) Machine the seat inner face till dimension "b" of the valve contact face is restored, attaining the specified γ taper.

Height of inner face:

Intake: $b = 1.07 \div 1.37$ mm
(0.0421 \div 0.0539 in)

Exhaust: $b = 1.26 \div 1.56$ mm
(0.0496 \div 0.0614 in)

Taper of valve seat lower face:

Intake: $\gamma = 50^\circ$

Exhaust: $\gamma = 30^\circ$

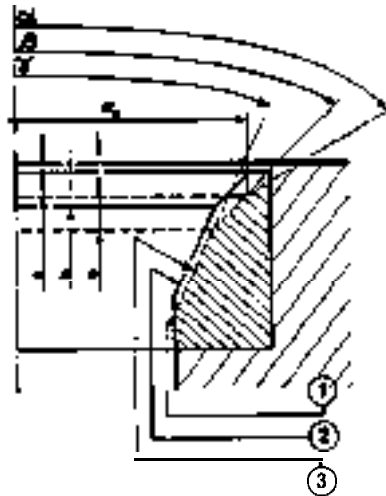

1 Valve seat 3 Profile after max. regrinding
2 Original profile

(4) Having completed all machining, lap valve seats with proper tool.

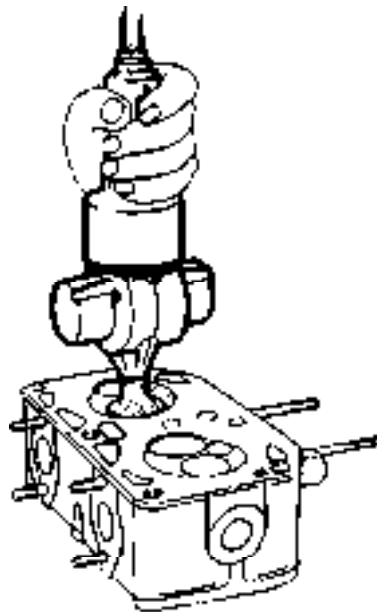

For seat lapping use the proper lapping compound (SIPAL AREXONS Carbo-silicium for valves - Std. no. 4100-31502).

Valve seat replacement

1. Remove worn valve seats using the proper tool.
2. With a set of new valve seats verify that dimensions shown in the following table are complied with:

	Valve	Engine		
		1200	1350	1500
Valve seat outer diameter mm (in)	i.	38.875 \div 38.9 (1.5305 \div 1.5315)		
	e.	33.375 \div 33.4 (1.3140 \div 1.3150)		
Diameter of valve Seat recess mm (in)	i.	38.8 \div 38.825 (1.5276 \div 1.5285)		
	e.	33.3 \div 33.325 (1.3110 \div 1.3120)		

i. = intake valve
e. = exhaust valve

3. Oven preheat the head at 140°C (284°F).
4. Fit new valve seats using the proper tool.

Checking valve tightness

When replacing guides, after regrinding and lapping of seats, it is advisable to test valve tightness - with valves and sparkplugs duly mounted - according to the following procedure:

1. Mount the head on tool A.2.0226 and A.2.0195 previously secured in a vice.
2. Fill the combustion chamber with gasoline.
3. Let some low-pressure air into the intake ducts and check for presence of air bubbles in the gasoline.

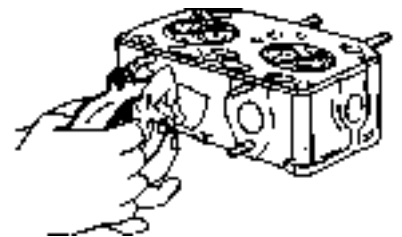

4. Follow the same procedure and check tightness of the exhaust valves by letting low pressure air into the exhaust valve ducts.
5. Should there be some leaks, ascertain that valves are properly fitted in their seats and then repeat above tightness tests; if the results are negative, valve seats will need relapping as indicated in paragraph: Checks and Inspections - Cylinder Heads and Valves - Valve Seats.

SPRINGS

Visually check the springs for cracks and make sure they are not out-of-square if the evidenced flaws suggest it, check the technical data of the inner and outer springs and then with a dynamometer verify that their length under load falls within the values shown in the following table:

	Spring	Empire		
		1200	1350	1500
Load N (kg ; lb)	o.	425.32 ÷ 452.76 (43.4 ÷ 46.2 ; 95.68 ÷ 101.85)		
	i.	194.53 ÷ 208.25 (19.85 ÷ 21.25 ; 43.76 ÷ 46.85)		
Length under load mm (in)	o.	25.25 (0.9941)		
	i.	23.25 (0.9153)		

o. = outer spring
i. = inner spring

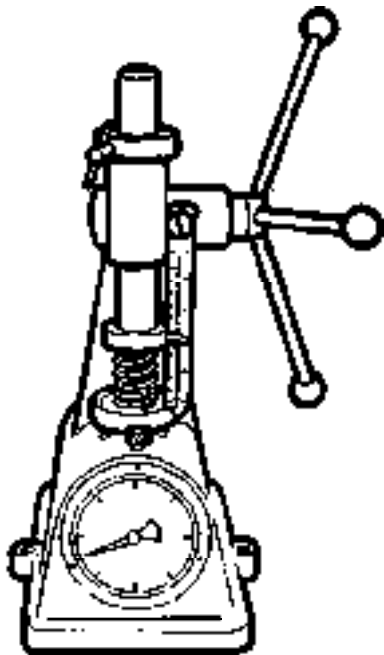

CUPS

Check that the outer surface of the cups as well as the upper surface on which cams work, show no scores, no evidence of pitting or abnormal wear. Further verify that-calking of the

cup's nut is intact and that the cup has retained its original punching position.

CAUTION:

Do not remove the valve clearance adjusting screw from the cup.

VALVES

Check and make sure that valves do not show any scores, burns or evidence of sticking with their corresponding cylinder head seats (forming a step); if they do, replace them.

CAMSHAFT SUPPORT

1. Visually check the seats of camshaft cups and journals for scores and for any evidence of pitting or abnormal wear.

(1) Reset reamer to testing dimension.

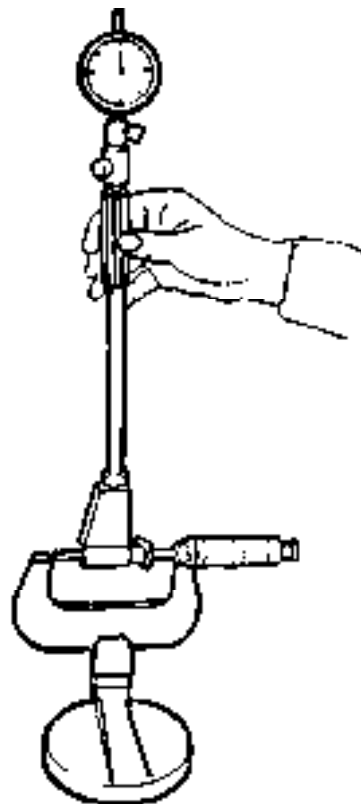

(2) Measure the diameter of camshaft bearings.



Diameter of camshaft bearings

Front = 35.015 ÷ 35.040 mm

(1.3785 ÷ 1.3795 in)

Centre = 46.500 ÷ 46.525 mm

(1.8307 ÷ 1.6317 in)

Rear = 47.000 ÷ 47.025 mm

(1.8504 ÷ 1.8514 in)

(3) Following the same procedure, measure the diameter of the four cup seats and determine the relevant fitting play.

Diameter of cup seats

36.00 ÷ 36.025 mm

(1.4173 ÷ 1.4183 in)

Max. cup-to-seat play

0.1 mm (0.0039 in)

CAMSHAFT

1. Carefully examine working surfaces of cams and of camshaft journals making sure that there are no scores, no evidence of seizure, overheating or abnormal wear.

2. With a micrometer measure the diameter of camshaft journals.

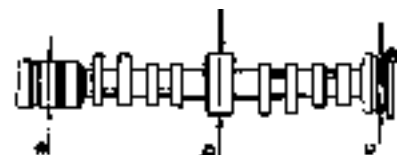

MAIN AND CONNECTING ROD BEARINGS

Thoroughly clean the main and connecting rod bearings and visually check them for scores as well as for any evidence of seizure.

In case of excess wear, replace all bearings. When fitting connecting rod bearings to the crankshaft, be sure to use matching parts, i.e. belonging to the same size class; for this purpose they are identified by same colour dots on the side of the half-bearing and on the relevant crank pin of the shaft. Applicable dimensions and tolerances are shown in: Service Data and Specifications "Connecting rod bearings" and "Main bearings" charts.

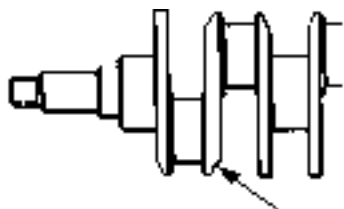

micrometer. For relevant dimensions and tolerances see: Service Data and Specifications - "Piston" chart.

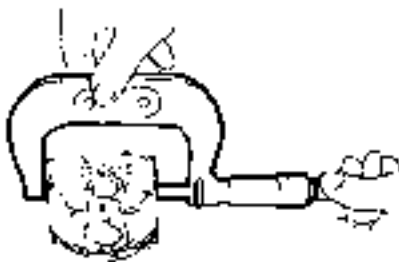

4. In case the connecting rod piston assembly has been disassembled, check the piston pin seats on the connecting rod small end as well as on the piston pin bosses for excess wear.

5. Should parts not be replaced and therefore used again, remember that working surfaces - especially that of the piston pin seat on the piston - must be totally free of any scores, even the slightest one.

The piston pin must always be replaced.

FLYWHEEL

1. Verify that teeth of gear are not in any way chipped or- show any evidence of pitting; contrarywise, replace the flywheel.

2. Check the clutch driven plate contact surface on the flywheel for any scores, chips or evidence of overheating. Before doing so, however, make sure that the contact surface has not been previously ground and that the amount of material, available for removal is going to be sufficient for elimination of the existing flaws.

For this purpose, verify that dimension "b" shown in the chart is greater than the min. specified limit and that the removable stock will allow surfacing as required.

Min. limit of dimension "b"
20.95 mm (0.8248 in)

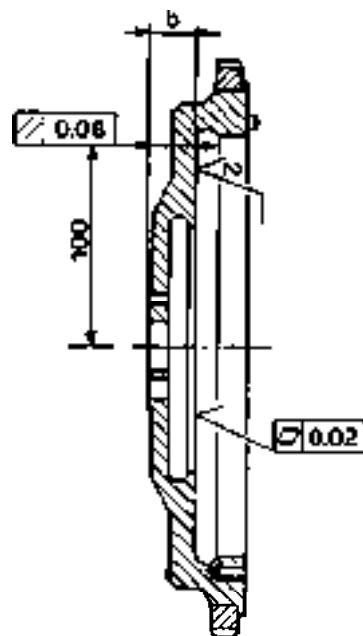

Surface grinding must be performed in accordance with the roughness, flatness and parallelism tolerances shown in the above chart.

CYLINDER BLOCK

1. Visually check cylinder block for cracks or excess wear of sliding surfaces.
2. Check cylinder walls surfaces for roughness.

Max. allowed roughness of cylinder wall surface
 $0.5 \div 1 \mu\text{m} (20 \cdot 10^{-6} \div 39 \cdot 10^{-6} \text{ in})$

3. See to which size class the cylinder walls refer to and then proceed to check them by measuring them. Cylinder walls are selected according to their inner diameter and are divided into five different classes: A, B, C, D, and E. The class identifying letters are stamped on the cylinder block upper surface next to each wall location.

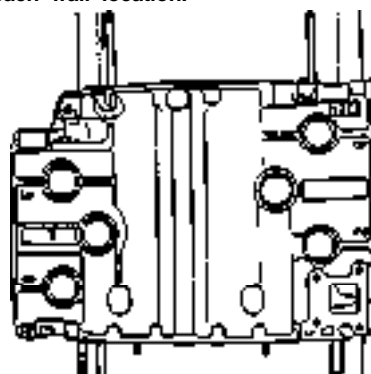

PISTONS AND CONNECTING RODS

1. Visually check pistons and connecting rods for cracks, scores and evidence of excess wear.

2. Measure the play between the rings and their seats in the piston. For relevant dimensions and tolerances see: Service Data and Specifications - "Pistons" and "Piston Rings" charts.

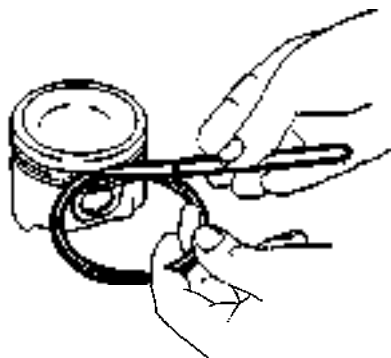

3. Check piston diameter with a

Dimensions relevant to each class are shown in: Service Data and Specifications "Cylinder block" chart.

(1) Reset the reamer by means of a micrometer.

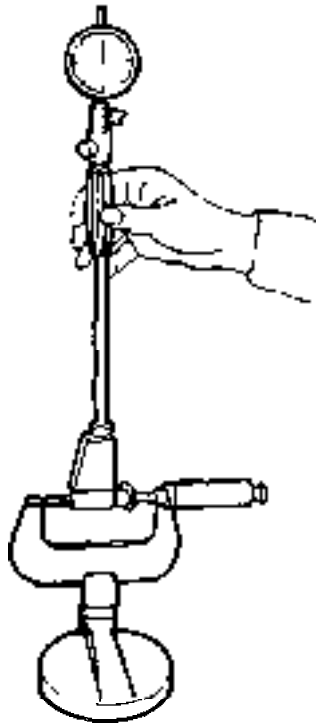

(2) Measure the diameter at the recommended depth and then determine taper and out-of-round of cylinders walls.

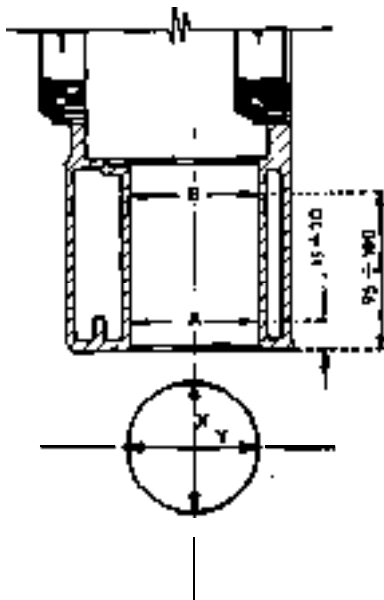

Cylinder wall max. taper:
 $A - B = 0.02 \text{ mm (0.00079 in)}$
 Cylinder wall max. out-of-round:
 $X - Y = 0.02 \text{ mm (0.00079 in)}$

(3) Compare actual values D with nominal ones C of each size class and then determine the cylinders walls max. wear.

Cylinder wall max. wear:
 $C - D = 0.04 \text{ mm (0.00157 in)}$

4. If the dimensions thus established are not within tolerance, cylinders walls must be rebored keeping in mind that three different oversize pistons are available as spare parts; this means that the diameter of walls will have to be in accordance with the tolerances shown in: Service Data and Specifications "Cylinder block" chart.

(1) Mount main bearing caps on the cylinder block and tighten screws as specified in: "Engine assembly - Engine unit".

Then proceed to bore cylinder walls so as to stay within the tolerances shown in: Service Data and Specifications - "Cylinder block" chart.

Lapping must be performed so that tool marks cross each other at an angle of $90^\circ \div 1203$

(2) If wear does not exceed the specified limit but pistons and spring rings need replacing because of some flaws or damage, cylinders walls will need at least to be lapped; in this case measure the diameter of the walls in order to identify the new size class to which they belong and that will have to be kept in mind during piston fit operations, regardless of the letter stamped on the cylinder block. Should lapping cause a size class change, cylinder wall will no longer be identifiable through the letter stamped on the cylinder block which, therefore, must be erased in order to avoid mistakes during future operations.

PISTON - CYLINDER WALL FIT

1. When original parts are involved, they will be selected by matching each cylinder wall identification letter that is stamped on cylinder block upper surface to the piston that has the same letter stamped on its head or a coloured dot painted on the inside of its crown, according to the following schedule:

Engine	Wall \emptyset identifying letter	Piston identifying letter and colour
1200	A	A - blue
	B	B - pink
1350	C	C - green
1500	D	D - yellow
	E	E - white

If the letter stamped on the cylinder block has been previously erased, matching will take place according to the identification letter stamped on the piston that needs replacing; in this instance, it is advisable to make a double check and measure the cylinder wall diameter.

2. When oversize walls are used, they will be matched to the relevant completely assembled pistons, namely with compression rings and oil scraper ring, which are available as spare parts according to the following oversize scale: G.2 - 0.4 - 0.6 mm (0.0078 - 0.0157 - 0.0236 in).

Cylinder wall to piston play
 Standard $0.03 \div 0.05$ mm
 ($0.0012 \div 0.0020$ in)
 Oversize $0.03 \div 0.06$ mm
 ($0.0012 \div 0.0024$ in)

2. Apply engine oil to piston pin, to the connecting rod small end, and to the piston pin supports.
3. Fit the connecting rod small end between the piston pin supports ensuring that holes are perfectly aligned in order to allow proper piston pin fit.
4. Fit the piston pin ② into the piston ④ and connecting rod ①, and then lock it with two spring rings ③.
- a. Position pistons so that the arrow stamped on their crown points in the direction of engine rotation, namely: upward for the right head pistons and "downward for the left head pistons.
- b. Fit connecting rods in the pistons so that the position of matching identification numbers and arrows corresponds to that shown in the below Figure.

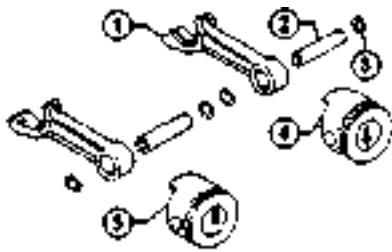

- 1 Connecting rod
- 2 Piston pin
- 3 Spring ring
- 4 Left head piston (No. 2 and 4)
- 5 Right head piston (No. 1 and 3)

5 With the help of a suitable special pliers, fit piston rings in the piston seat making sure that the marking stamped on the flat surface of the rings faces upwards.

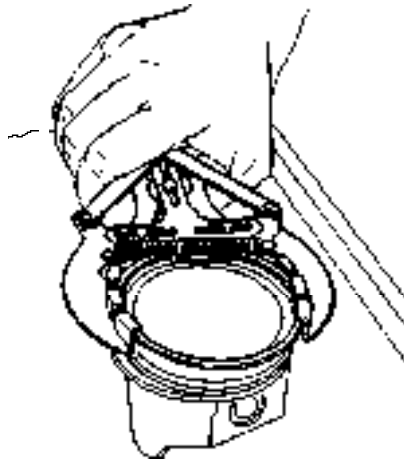
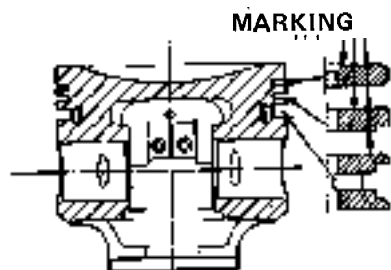

CRANKSHAFT

1. Fit rear bushing and oil pump drive gear on the crankshaft.
 - (1) Fit the crankshaft rear bushing ① by means of tool A.3.0450.
 - (2) Heat the oil pump and distributor drive gear to 150°C (302°F).
 - (3) Shrink the gear ② on the crankshaft positioning it so that the axis of the flywheel centering dowel and the front surface of one of the gear's form the specified angle.

Positioning of crankshaft rear gear
 $\alpha = 22^{\circ} \div 26^{\circ}$



- 1 Bush
- 2 Pump drive gear

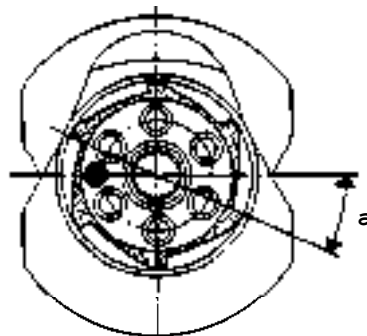

ENGINE UNIT

1. Fit crankshaft on cylinder block.
 - (1) Fit main bearings on relevant main bearings supports and lubricate

them with oil. Select bearings according to the diameter of crankshaft journals.



- (2) Fit thrust half-rings on the relevant seat obtained in the third main bearings support. Make sure that these half-rings are fitted with oil channels facing the crankshaft shoulders.



- (3) Place crankshaft on main bearing supports.
2. Fit main bearing caps on cylinder block,
 - (1) Fit main bearings to main bearing caps and lubricate them with oil.

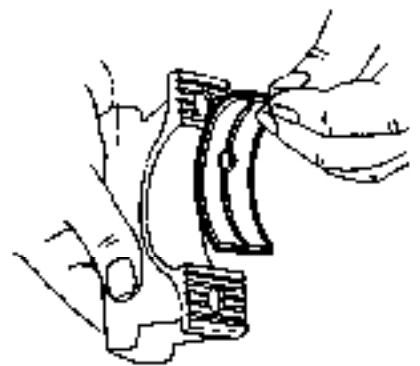

- (2) Fit main bearing caps: front ① (see markings), centre ②, and rear ③, fitted with relevant bearings, on cylinder block supports. Coat supports with engine oil and tighten oiled screws without fully locking them.
- (3) Tighten screws securing the main bearing caps to the relevant cylinder block supports in two or three

successive steps, according to specified torque and sequence (from A to F).

T: Tightening torque

Caps to cylinder supports securing screws:

- 66 ÷ 73 N · m
- (6.7 ÷ 7.4 kg · m
- 46.4 ÷ 53.5 ft · lb)

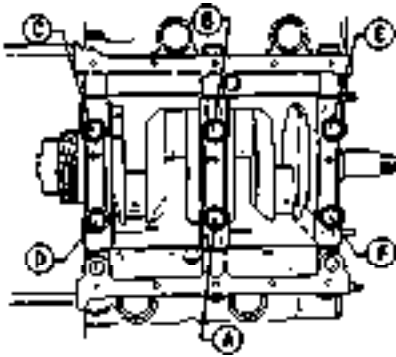

(4) Subsequently tighten screws securing the main bearing caps to the cylinder block in two or three successive steps, according to specified torque and sequence (from A to F).

T: Tightening torque

Caps to cylinder block supports securing screws

- 40 ÷ 49 N · m
- (4.1 ÷ 5 kg · m
- 29.6 ÷ 36.2 ft · lb)

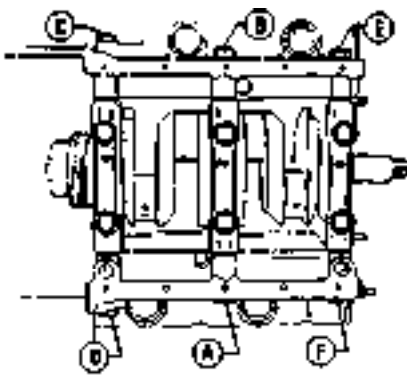

Having completed tightening of all screws, apply engine oil to the supports and rotate the crankshaft by hand.

3. Check crankshaft end play.
(1) Attach a centesimal dial gauge with magnetic base to the cylinder

block having the gauges indicating finger touch the crankshaft parallel-wise to the shaft's axis.

(2) Using a screwdriver, move the crankshaft along its axis and check the gauges reading to ensure that "g" end play is within specified values.

Crankshaft end play
0.35 mm (0.0137 in)

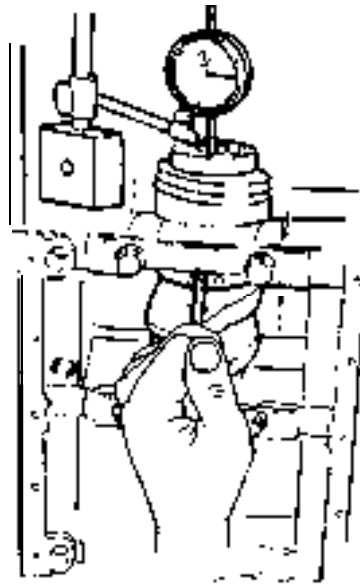

(3) If the shaft has not been previously reground and therefore the value established as per step above is greater than the specified value, it is possible to regrind the shoulders of the rear journal till its "c" length is such that it will allow fitting of the oversize thrust half-rings available as spare parts.

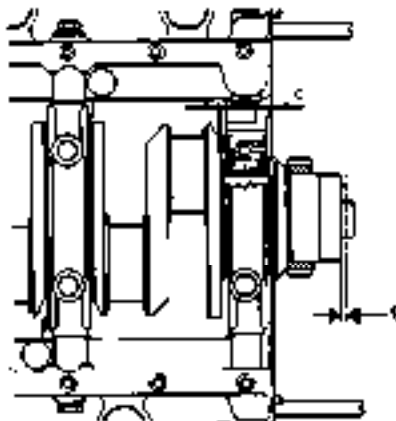

Rear journal "c" length
28.764 ÷ 28.804 mm .
(1.1324 ÷ 1.1340 in)

4. Fit seal ring in the main oil gallery of the cylinder block rear cover.

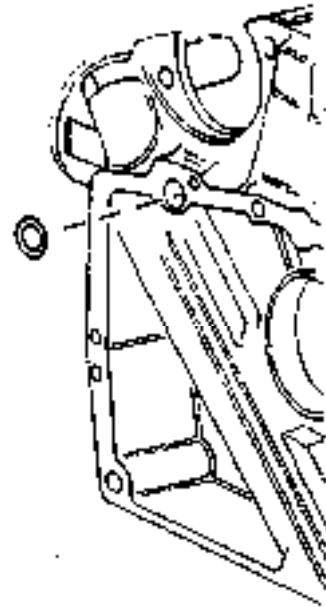

5. Fit rear cover, with relevant gasket, on the cylinder block. Tighten all cover retaining screws according to specified torque.

T: Tightening torque

Rear cover retaining screws

- 19 ÷ 24 N · m
- (1.9 ÷ 2.4 kg · m
- 13.7 ÷ 17.4 ft · lb)

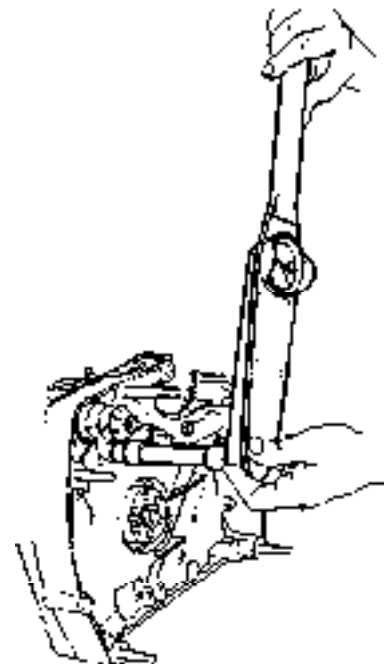

6. Fit crankshaft oil seal ring using tool A-3.0337.

a. Apply engine oil to the rings sealing lip, its external surface as well as to its working seat.

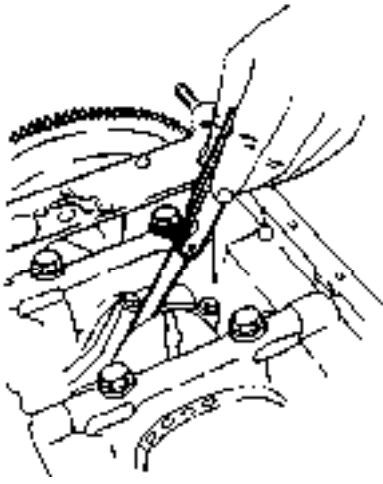

10. Fit front cover, with proper gasket, to cylinder block and tighten screws and nuts according to specified torque.

T: Tightening torque
 Front cover to cylinder block retaining screws:
 19 ÷ 24 N-m
 (1.9 ÷ 2.4 kg-m
 13.7 ÷ 17.4 ft.lb)

11. Fit the engine front support **2** and the pulleys lower guard **1** to the cover.

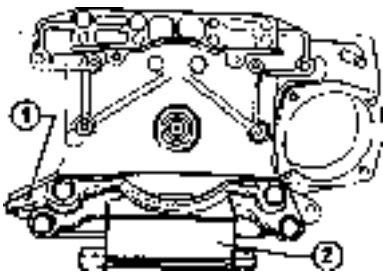

1 Pulleys guard 2 Front support

12. Fit crankshaft oil seal front ring using tool A.3.0338. Before doing so, apply a coating of engine oil to the rings sealing lip and work surface.

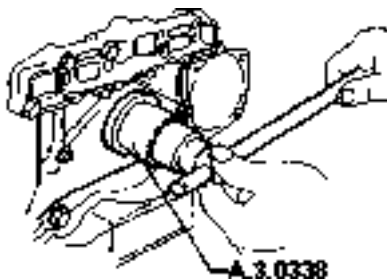

13. Fit crankshaft front pulleys. (1) Key the below mentioned parts according to the indicated sequence: the belt guide washer **8**, the left head camshaft drive toothed pulley **7**, the spacer **6**, the right head camshaft drive toothed pulley **5**, the water pump and alternator drive pulley **4**, the spacer **3**, and the washer **2**.

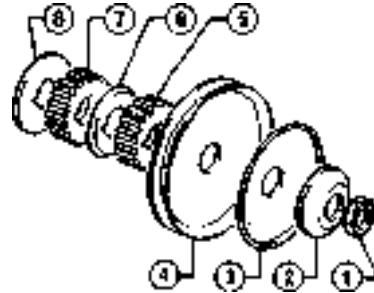

1 Nut 5 Toothed pulley
 2 Washer 6 Spacer
 3 Spacer 7 Toothed pulley
 4 Pulley 8 Washer

(2) After having suitably locked flywheel rotation, tighten pulley retaining nut according to specified torque.

T: Tightening torque
 Pulleys to cylinder block retaining nut:
 118 ÷ 144 N-m
 (12 ÷ 14.7 kg-m
 86.8 ÷ 106.3 ft.lb)

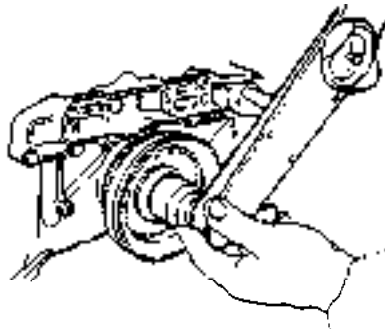

14. Fit the water pump.
 (1) Fit new gasket **1** on pump.
 (2) Fit pump **2**, without pulley, on cylinder block.
 (3) Fit screws **3** with washers and tighten them to specified torque value.

T: Tightening torque
 Screws securing water pump
 19 ÷ 24 N-m
 (1.9 ÷ 2.4 kg-m
 13.7 ÷ 17.4 ft.lb)

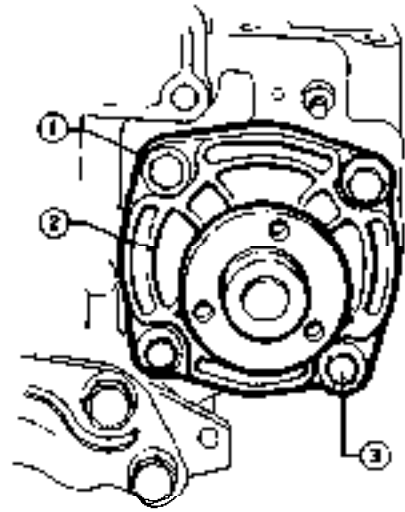

1 Gasket 3 Screw
 2 Pump

15. Fit cylinder heads.
 (1) Turn crankshaft till the piston in No. 1 cylinder is set at Top Dead Center in the compression stroke; this correct positioning is further ensured by the "T" notch **1** on the flywheel matching with the reference **2** on the rear cover **3**.

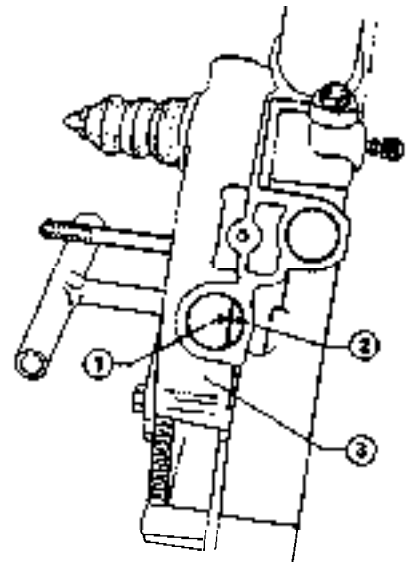

1 Notch 3 Cylinder block rear cover
 2 Reference

(2) Align the references shown on the camshaft rear journal and on the support rear side panel.

ENGINE MAIN MECHANICAL UNIT

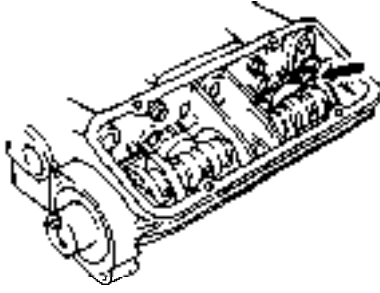

(3) Fit cylinder heads, with relevant gaskets, on the cylinder block.

By extremely careful during this assembly operation in order to avoid that opened valves, projecting above the head surface, might strike the cylinder block surface and thus be damaged.

(4) Position and then tighten the six cylinder heads retaining screws (1) in two or three successive steps, according to the specified torque and sequence (from A to F).

(5) Tighten screws (2) securing the camshaft support to the cylinder heads.

T: Tightening torque

Head to cylinder block retaining screws:

81 ÷ 87 N·m

(8.3 ÷ 8.9 kg·m)

60 ÷ 64.4 ft·lb)

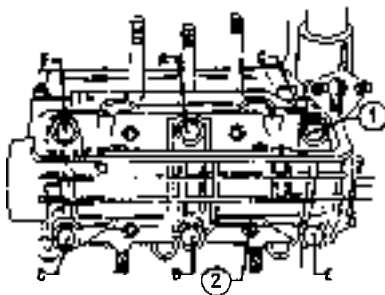

1 Head retaining screw

2 Camshaft support retaining screw

In case of in-car tightening, use extension spanner A.5.0198 in accordance with the following tightening torques:

— for torque spanner with 300 mm (11.811 in) lever arm:

57 ÷ 62 N·m

(5.8 ÷ 6.3 kg·m)

41.9 ÷ 45.6 ft·lb)

for torque spanner with 400 mm (15.748 in) lever arm
62 ÷ 67 N·m
(6.3 ÷ 6.8 kg·m
45.6 ÷ 49.2 ft·lb)

16. Fit camshaft belts rear covers.
17. Fit belt tensioner assemblies on the cylinder block pins according to the following sequence: supports (5), spring (4), washers (3) and washers (2). Lock belt jockey pulley assemblies with relevant nuts (1) after having pre-loaded belt jockey pulley in order to allow for belt passage.

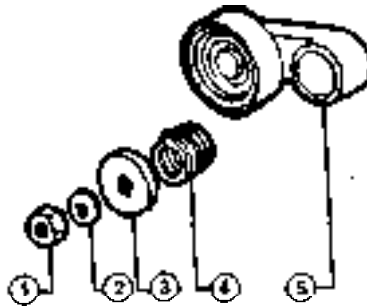

1 Nut
2 Washer
3 Washer

4 Spring
5 Support

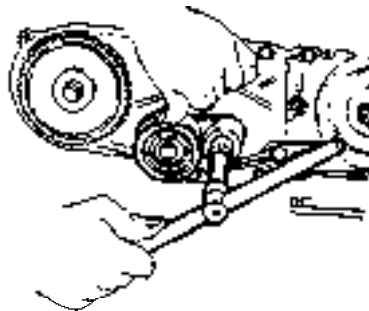

18. Fit camshaft driving belts.

(1) Fit camshaft drive pulleys and tighten the retaining screw to specified torque being careful, at the same time, to stop pulley rotation by means of toothed spanner A.5.0195.

T: Tightening torque

Camshaft pulley retaining screw:

63 ÷ 70 N·m

(6.4 ÷ 7.1 kg·m)

46.3 ÷ 51.3 ft·lb)

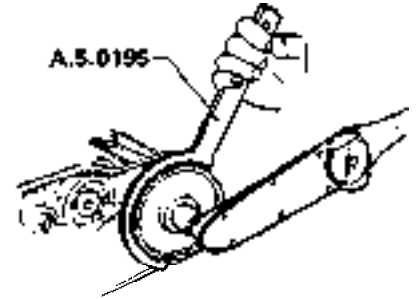

(2) Verify that the crankshaft's angular position corresponds to the Top Dead Center of cylinder No.1, as previously mentioned for heads assembly.

(3) Rotate camshaft by means of toothed spanner A.5.0195 till the reference stamped on the supports rear side panel is aligned with the one stamped on the shaft's rear journal.

(4) Key camshaft drive belts on the crankshaft inner pulleys and on the pulleys of both camshafts. Belt keying must take place with the belt pulling section, opposite the jockey pulleys, fully stretched.

(5) Check that "s" clearance between the camshaft belt and the profile of the engine front support is not below the specified min. value; if it is, modify the profile of the support till it meets the specified value.

"S" min. clearance between camshaft belt and engine from mounting
9 mm (0,3543 in)

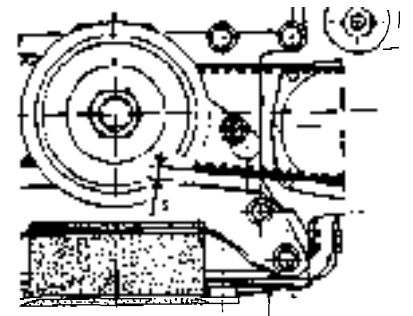

(6) Completely loosen the belt jockey pulley lock nuts and then tighten them again.

(7) Turn the crankshaft a few times in its working direction so that the belts may take up their final position.

(8) Act on the camshaft till cams are disengaged; loosen the belt jockey pulley lock nut and then retighten it according to specified torque.

T: Tightening torque
 Belt jockey pulley lock nut
 (with cold engine)
 37 ÷ 46 N·m
 (3.8 4 4.7 kg·m
 27.5 ÷ 34 ft·lb)

19. Fit oil pump.

(1) Turn crankshaft till piston No. 1 is at Top Dead Center in the compression stroke, as mentioned for heads reassembly.

(2) Turn the pump drive shaft so that the next rotation, which will follow mating of the pump drive gear with that on the crankshaft, will position the distributor coupling according to the specified β angle.

Apply a coating of engine oil to the drive shaft.

Distributor coupling positioning
 $\beta = 22^\circ$

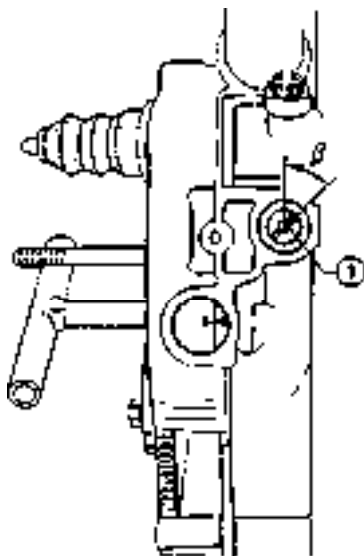

1 Distributor coupling

(3) Fit the oil sump pump on rear cover and tighten screws ① according to specified torque.

T: Tightening torque
 Oil sump to rear cover retaining screws
 19 ÷ 24 N·m
 (1.9 ÷ 2.4 kg·m
 13.7 ÷ 17.4 ft·lb)

(4) Tighten retaining screws ② between pump body and support according to specified torque.

T: Tightening torque
 Pump body to support retaining screws:
 8 ÷ 10 N·m
 (0.8 ÷ 1 kg·m
 5.8 ÷ 7.2 ft·lb)

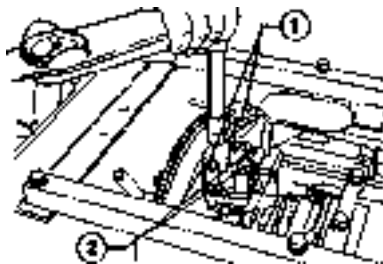

1 Pump to rear cover retaining screws
 2 Pump body to support retaining screw

(5) Reassemble oil sump with proper gasket ② and tighten all retaining screws. Before doing so, evenly apply the specified cement to the gasket (Cement Std. No. 3522-00040 DOW CORNING Silastik 732 RTV).

Before applying the sealant, remove all traces of old sealant and of oil from all surfaces.



1 Oil sump 2 Gasket

20. Fit distributor on rear cover.

(1) Turn the distributor's shaft so that the rotor arm ① is positioned on the reference mark stamped on the distributor's body.

The rotor arm ① should point toward the No. 1 cylinder. This position corresponds to ignition in No. 1 cylinder and to correct coupling of the oil pump and distributor shafts.

(2) If necessary, correct misalignment of the rotor arm with the reference mark stamped on the distributor's body by rotating the latter and then tightening the lock nut ② securing the distributor to the cylinder block rear cover.

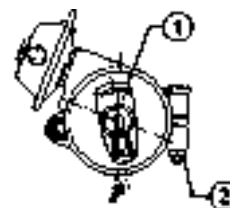

1 Rotor arm 3 Distributor shaft
 2 Distributor lock -coupling nut

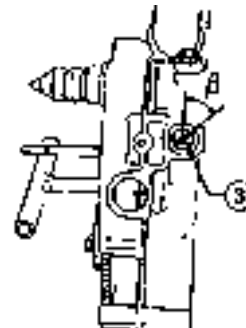

21. Adjust clearance of intake and exhaust valves while engine is cold. The relevant procedure is described in Group 00 - Engine Maintenance.

Valve clearance (cold engine):

Intake

0.35 ÷ 0.40 mm
 (0.0138 ÷ 0.0157 in)

Exhaust

0.45 ÷ 0.50 mm
 (0.0177 ÷ 0.0197 in)

22. Fill chambers of camshaft supports with engine oil.

Oil quantity required for fill-up
 0.250 kg (0.5511 lb)
 in each chamber

23. Fit support covers ① with relevant gaskets ②.

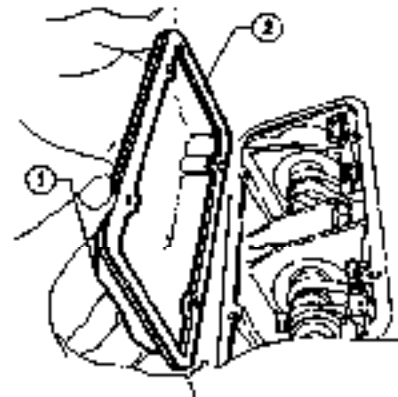

1 Cover 2 Gaskets

34. Assemble carburetor with spacer and the interposed gaskets on intake manifold studs.

T: Tightening torque
 Carburetor nuts
 19 ÷ 24 N·m
 (1.9 ÷ 2.4 kg·m
 13.7 ÷ 17.4 ft·lb)

35. Perform following connections.

- Fuel supply pipe (2) from fuel pump to carburetor.
- Vacuum advance pipe (1) from carburetor and advance controller located on distributor.

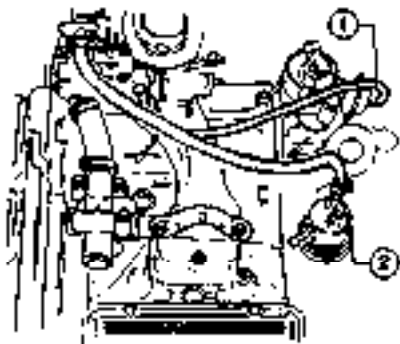

1 Advance pipe 2 Fuel supply pipe

36. Fit oil filter by manually tightening it and insert dipstick.

37. By means of adapter A.5.0115 fit spark plugs tightening them according to specified torque.

T: Tightening torque
 Spark plugs:
 25 ÷ 34 N·m
 (2.5 ÷ 3.5 kg·m
 18.1 ÷ 25.3 ft·lb)

38. Secure cap to distributor body with relevant springs, then connect ignition cables between spark plugs and distributor cap, securing them to relevant clamps.

Cables connection must take place according to the ignition sequence of cylinders.

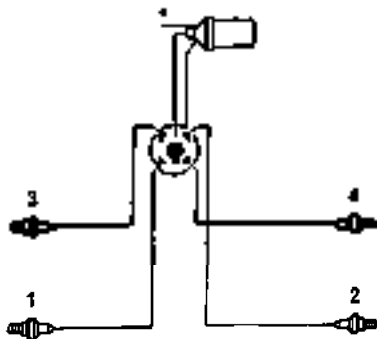

39. Fit alternator and control belt.
 (1) Secure bracket (4) to engine front cover and tightening the relevant screw (3)
 (2) Position alternator on engine support and tighten bolts (1) without fully locking them.

(3) Key alternator and water pump drive belt on relevant pulleys.

(4) Adjust belt tension according to specified value and then lock bolts (1). For adjusting procedure refer to Group 00 - Engine Maintenance.

Load: 78.40 N (8 kg) (17.4 lb)
 Arrow: 15 mm (0.5905 in)

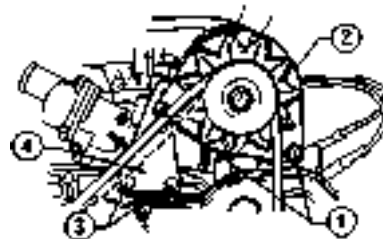

1 Bolts 3 screws
 2 Alternator 4 Bracket

40. Fill the engine with specified engine oil (AGIP Sint 2000 10W50 or IP Super Motor Oil 10W50).

Oil quantity required for fill-up
 3.6 kg (7.93 lb)

ENGINE LUBRICATION SYSTEM

DESCRIPTION

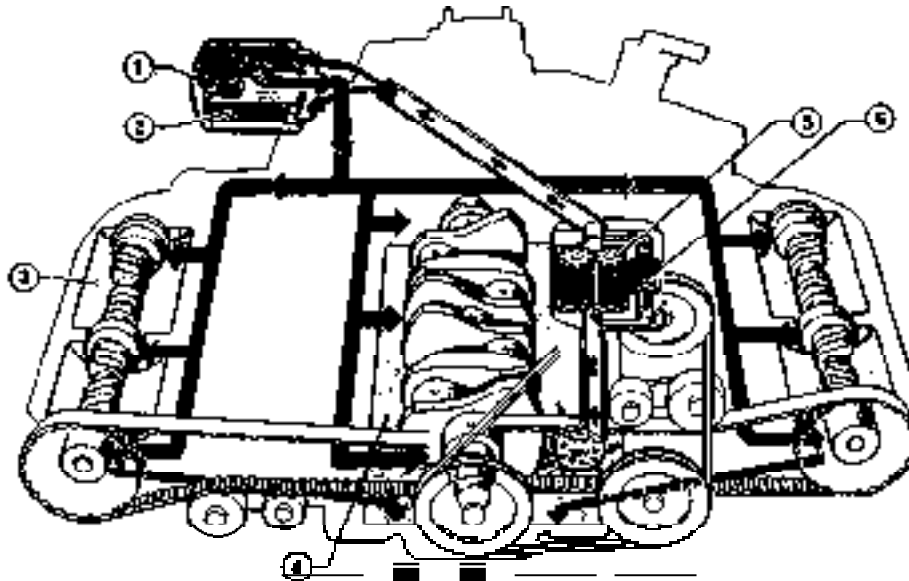

- | | |
|----------------------------|-------------------------|
| 1 Bypass valve | 4 Oil sump |
| 2 Oil filter | 5 Gear pump |
| 3 Camshaft bearing housing | 6 Pressure relief valve |

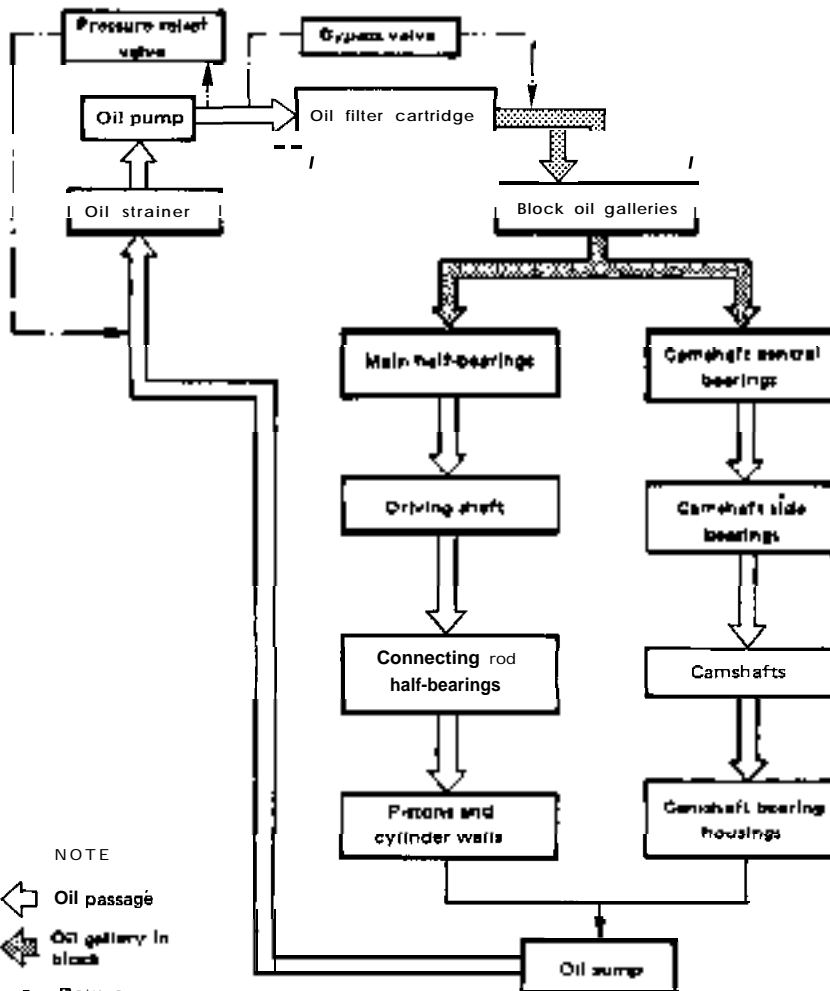

NOTE

Oil passage
 Oil gallery in block
 Return
 Bypass passage

The engine is pressure lubricated by means of a gear pump. The pump is mounted on the rear cover of the engine and is actuated by a shaft which is driven by a gear fitted to the crankshaft.

The maximum oil pressure is adjusted by means of a proper valve fitted on the pump.

Oil is completely filtered in the suction head by a strainer then by a filter with cartridge placed on the oil passage and provided with a bypass safety valve, should the cartridge become clogged.

The oil filter, on the engine rear cover, has unions for the recirculation of the oil vapours at minimum and high running.

The insufficient oil pressure is indicated on the combination meter by means of a warning light connected to a manual contact inserted on the main oil gallery of the block.

OIL PUMP

OIL PRESSURE CHECK

1. Start engine and heat oil to 90°C (194°F).
2. Remove oil pressure checking manual contact.
3. Fit gauge to manual contact hole.
4. Start engine and record oil pressure as shown on gauge.

Engine	Engine speed r.p.m.	Oil pressure kPa (bar, kg/cm ² , psi)
1200	800	117.7 ÷ 274.6 (1.18 ÷ 2.75, 1.2 ÷ 2.8, 17.07 ÷ 39.82)
1350		
1500	5500	411.8 ÷ 568.7 (4.12 ÷ 5.69, 4.2 ÷ 5.8, 59.74 ÷ 82.49)

5. Remove gauge and refit manual contact.

If the oil pressure value is not within the limits shown in table, the oil pump is to be checked.

REMOVAL

Remove fuel pump from cover (see: Engine Disassembly - Engine Unit).

1. Drain engine oil and remove oil sump. If required, tap with a wooden mallet on attachment side of sump to block.
2. Unscrew screws (7) and withdraw pump from its seat.

DISASSEMBLY AND ASSEMBLY

1. Unscrew screws (6) securing pump body to pump support.
2. Withdraw driven gear (3), valve (12), spring (11) and washer (10).
3. Reassemble pump carrying out the above procedure but in the reverse sequence. Slightly tighten screws (6) without locking fully home.
4. Manually rotate driving shaft checking for crawling and regular rotation.

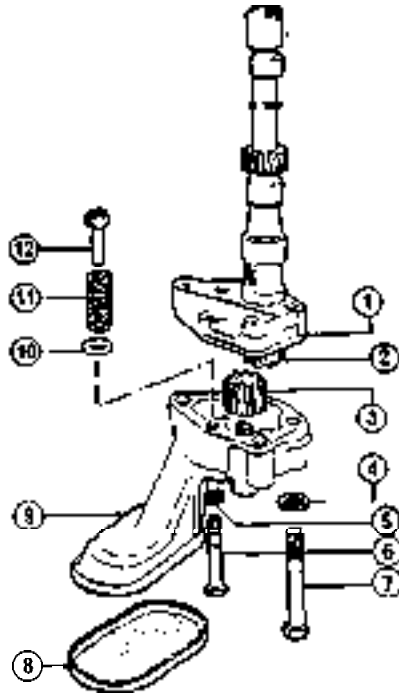

- | | |
|-----------------|-------------|
| 1 Upper support | 7 Screw |
| 2 Driving gear | 8 Strainer |
| 3 Driven gear | 9 Pump body |
| 4 Washer | 10 Washer |
| 5 Washer | 11 Spring |
| 6 Screw | 12 Valve |

CHECKS AND INSPECTIONS

1. Check gears for wear, ensure that teeth are free from cutting or chipping or that wear is regular and not excessive on all the face length.
2. Check driven gear pin for indications of seizing and cutting.
3. Carry out same check as above for the pressure regulator valve, additionally ensuring that it slides in its seat on pump body without crawling. If the spring of the pressure regulator valve is supposed to have yielded, also considering the trouble shown, replace valve.
4. Check that driving gear is correctly positioned on driving shaft of oil pump and that crankshaft driving gear has the pin regularly fitted.
5. Finally check working surfaces of shaft and rear cover, of driving cam of fuel push rod, and the attachment point to the distributor for cutting and signs of seizure.

INSTALLATION

1. Lubricate driving shaft with engine oil as per step 4.
2. Refit oil pump carrying out procedure detailed in: Engine As-

sembly Engine Unit.

3. Tighten screws (2) securing pump to engine rear cover then screws (1) fastening pump body to pump support to the specified torque value.

- (T): Tightening torque
- Screws securing pump to engine rear cover
 19 ÷ 24 N-m
 (1.9 ÷ 2.4 kg-m
 13.7 ÷ 17.4 ft-lb)

- Screws fastening pump body to pump support
 8 ÷ 10 N-m
 (0.8 ÷ 1 kg-m
 5.8 ÷ 7.2 ft-lb)

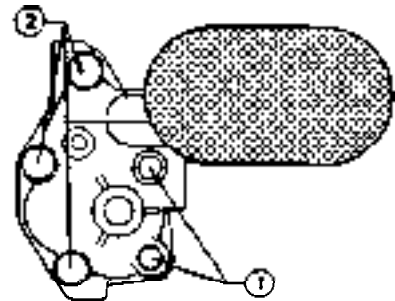

- 1 Screw fastening pump to pump support
 2 Screw securing pump

4. Fill engine with the specified engine oil (AGIP Sint 2000 10W50 or IP Super Motor Oil 10W50).

OIL FILTER REPLACEMENT

1. Drain hot oil of engine from sump.
2. Remove filter using proper tool.

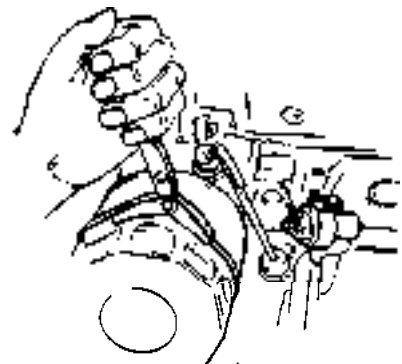

3. Fit a new filter of the prescribed type. Manually screw in the filter.
4. Fill engine with prescribed engine oil. After fitting new filter, let engine run for a few minutes and check for oil leakages.

-ENGINE MAIN MECHANICAL UNIT

INSPECTION AND ADJUSTMENT

CAMSHAFT SYSTEM

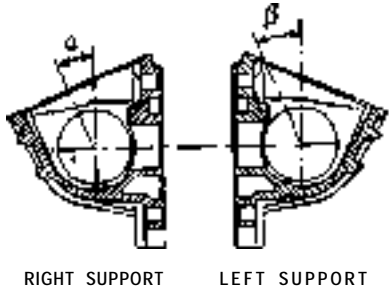

Unit: mm (in)

Engine		
1200	1350	1500
306.00	305.02	305.04

Camshaft		531.364	531.364	531.364
Tappet clearance	Intake	0.35 ÷ 0.40 (0.0138 ÷ 0.0157)		
	Exhaust	0.45 ÷ 0.50 (0.0177 ÷ 0.01971)		
Value of the angle of timing marks on camshaft supports	Right support	23°		
	Left support	23°		

All values are with cold engine

CHECKING VALVE OPENING AND CLOSING ANGLES

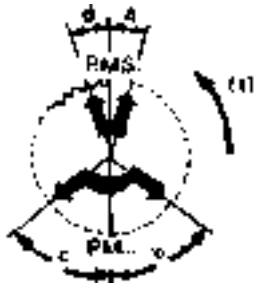

Unit: mm (in)

Engine		
1200	1350	1500
305.00	305.02	305.04

Intake	Valve clearance for checking	m m (in)	0.7 (0.0276)
	Opening BTDC	a	12°
	Closing ABDC	b	48°
Exhaust	Valve clearance for checking	m m (in)	0.7 (0.0276)
	Opening BTDC	c	45°
	Closing ABDC	d	7°

(1) Crankshaft rotation ACW seen from flywheel side.

ENGINE MAIN MECHANICAL UNIT

CYLINDER BLOCK

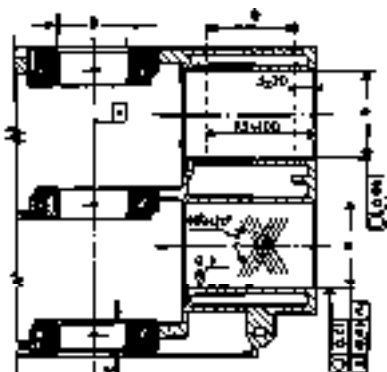

Unit: mm (in)

inspection data			Engine		
			1200	1350	1500
Cylinder bore "a"	Standard	Class A	80.00±80.01 (3.1496 ÷ 3.1500)		84.00±84.01 (3.3071 - 3.3075)
		Class B	80.01 ÷ 80.02 (3.1500 ÷ 3.1504)		84.01 ÷ 84.02 (3.3075 ÷ 3.30791)
		Class C	80.02 - 80.03 (3.1504 ÷ 3.1508)		84.02 G-84.03 (3.3079 ÷ 3.3083)
		Class D	80.03 ÷ 80.04 (3.1508 ÷ 3.1512)		84.03 ÷ 84.04 (3.3083 ÷ 3.3087)
		Class E	80.04 ÷ 80.05 (3.1512 ÷ 3.1516)		84.04 ÷ 84.05 (3.3087 ÷ 3.3091)
	Oversize	1st	80.20 ÷ 80.21 (3.1575 ÷ 3.1579)		84.20 ÷ 84.21 (3.3150 ÷ 3.3154)
2nd		80.40 ÷ 80.41 (3.1654 ÷ 3.1658)		84.40 ÷ 84.41 (3.3229 ÷ 3.3233)	
3rd		80.60 ÷ 80.61 (3.1733 ÷ 3.1737)		84.60 ÷ 84.61 (3.3307 ÷ 3.3311)	
Out-of-square between cylinder bore centreline and centreline of main bearings			0.05 (0.00197)		
Taper and out-of-round limit		Standard	0.01 (0.00041)		
		Max	0.02 (0.0008)		
Cylinder bore surface roughness			$0.5 \cdot 10^{-3} \div 1 \cdot 10^{-3}$ (0.0197-1 0 ⁻³ ÷ 0.0394-10 ⁻³)		
Cylinder bore grinding angle			90° ÷ 120°		
Main bearing diameter "b"		Front	63.663 ÷ 63.673 (2.5064 ÷ 2.5068)		
		Rear	63.673 - 63.683 (2.5068 ÷ 2.5072)		
		Central	63.673 - 63.683 (2.5068 ÷ 2.5072)		
Width of rear main bearing support "c"			23.68 ÷ 23.73 (0.9323 ÷ 0.9343)		

ENGINE MAIN MECHANICAL UNIT

PISTONS, COMPRESSION RINGS AND PINS

Pistons

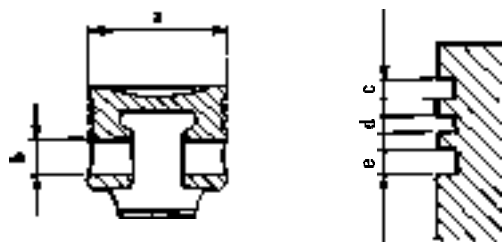

Unit: mm (in)

Inspection data			Engir		
			1200	1350	1500
Piston diameter "a" (1)	Standard	Class A (Blue) Class B (Pink) Class C (Green) Class D (Yellow) Class E (White)	79.96 ÷ 79.97 (3.1480 ÷ 3.1484) 79.97 f79.98 (3.1484 ÷ 3.1488) 79.98 ÷ 79.99 (3.1488 ÷ 3.1492) 79.99 ÷ 80.00 (3.1492 e-3.14961) 80.00 G-80.01 (3.1496 ÷ 3.1500)		83.96 ÷ 83.97 (3.3055 ÷ 3.3059) 83.97 ÷ 83.98 (3.3059 ÷ 3.3063) 83.98 -83.99 (3.3063 ÷ 3.3067) 83.99 ÷ 84.00 (3.3067 ÷ 3.3071) 84.00-84.01 (3.3071 f3.3075)
	Oversize	1st 2nd 3rd	80.15 ÷ 80.17 (3.1555 ÷ 3.1563) 80.35-80.37 (3.1634 ÷ 3.1642) 80.55 ÷ 80.57 (3.1713 ÷ 3.1720)		84.15 ÷ 84.17 (3.3130 ÷ 3.3138) 84.35f84.37 (3.3209 ÷ 3.3217) 84.55 ÷ 84.57 (3.3287 -3.3296)
First compression ring groove height "c"			1.525 ÷ 1.545 0.0600 ÷ 0.0608)	1.525 ÷ 1.550 (0.0600 ÷ 0.0610) (2) 1.525 ÷ 1.545 (0.0600 ÷ 0.0608) (3)	1.525 ÷ 1.545 (0.0600 ÷ 0.0608)
Second compression ring groove height "d"			1.775 ÷ 1.795 0.0699 ÷ 0.0707)	1.775 ÷ 1.800 (0.0699 ÷ 0.0709) (2) 1.775 ÷ 1.795 (0.0699-0.0707) (3)	1.775 ÷ 1.796 (0.0699 ÷ 0.0707)
Oil scraper ring groove height "c"			4.015 G-4.035 0.1581 ÷ 0.1589)	4.015 ÷ 4.040 (0.1581 -0.1590) (2) 4.015 ÷ 4.035 (0.1581 ÷ 0.1589: (3)	4.015 e-4.035 (0.1581 ÷ 0.1589)
Pin seat bore "b"			21.002 ÷ 21.006 (0.8269 ÷ 0.8270)		

- (1) To be measured to right angle to the piston pin at 17 mm (0.6693 in) from piston skirt
- (2) Borg0 Piston
- (3) Mondial Piston

ENGINE MAIN MECHANICAL UNIT

CONNECTING ROD AND CONNECTING ROD BEARINGS

Connecting rod



Unit: mm (in)

Inspection data	Engine		
	1200	1350	1500
Small end bush bore diameter "a"	21.007 ÷ 21.015 (0.8270 ÷ 0.8274)		
Big end bore diameter "b"	52.696 ÷ 53.708 (2.0746 ÷ 2.1145)		

Connecting rod bearings

Unit: mm (in)

Inspection data		Engine				
		1200		1350		1500
<p>Connecting rod bearing thickness "a"</p>	Standard	Blue	1.831 ÷ 1.835 (0.0721 ÷ 0.0722)	Blue	1.830 ÷ 1.836 (0.0720 ÷ 0.0722)	
		Red	1.827 ÷ 1.831 (0.0719 ÷ 0.0721)	Red	1.826 ÷ 1.832 (0.0719 ÷ 0.0721)	
Connecting rod bearing thickness "a"	Oversize	1st	1.966 ÷ 1.962 (0.0770 ÷ 0.0772)			
		2nd	2.083 ÷ 2.089 (0.0820 ÷ 0.0822)			
		3rd	2.210 ÷ 2.216 (0.0870 ÷ 0.0872)			
		4th	2.337 ÷ 2.343 (0.0920 ÷ 0.0922)			

ENGINE MAIN MECHANICAL UNIT

FLYWHEEL

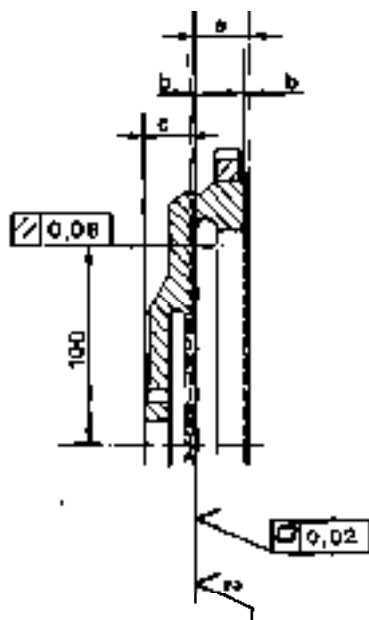

Unit: mm (in)

Inspection data		Engine		
		1200	1350	1500
Regrinding dimensions (1)	a	$24.0 \div 24.2$ (0.9449 \div 0.9528) ≤ 0.2 (0.0079) ≥ 20.95 (0.8248)		
	b			
	c			
Parallelism of the driven plate contact face compared with flywheel-to-crankshaft support face (as read at a 100 mm radius)		0.08 (0.0031)		
Maximum out-of-flat of driven plate contact face		0.02 (0.0008,		
Surface roughness of driven plate contact face		$2.1 \cdot 10^{-3}$ (0.0787~10")		

(1) The depot of regrinding, dimension "b", must be the same both on clutch driven plate contact face and on the face of the register for the clutch cover, so that dimension "a" kept constant. Dimension "c" must not be lower than the specified limit.

ENGINE MAIN MECHANICAL UNIT

Unit: mm (in)

Inspection data	Engine		
	1200	1350	1500
Max. misalignment between the centrelines of the two pairs of crankpins and the journals centreline	0.25 (0.0098,		
Max. out-of-square between thrust ring face and main journals	0.03 (0.00121		
Rear crankshaft bush diameter "b"	16.065 ÷ 16.080 (0.6325 ÷ 0.6331)		
Fitment of rear crankshaft gear "U" (distributor/oil pump drive)	22° ÷ 26°		

(1) Re-cutting equally spaced on both shoulders

Thrust rings

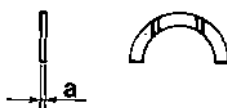

Unit: mm (in)

Inspection data		Engine		
		1200	1350	1500
Thickness "a"	Standard	2.310 ÷ 2.362 (0.0909 ÷ 0.0930)		
	Oversize	2.437 ÷ 2.489 (0.0959 ÷ 0.0980)		

Main -bearings



Unit: mm (in)

Inspection data		Engine		
		1200	1350	1500
Thickness "a"	Standard	1.832 ÷ 1.841 (0.0721 ÷ 0.0724)		
	Oversize	1st	1.959 ÷ 1.968 (0.0771 ÷ 0.0775)	
		2nd	2.086 ÷ 2.095 (0.0821 ÷ 0.0825)	
		3rd	2.213 ÷ 2.222 (0.0871 ÷ 0.0875)	
		4th	2.340 ÷ 2.349 (0.0921 ÷ 0.0925)	

ENGINE MAIN MECHANICAL UNIT

CAMSHAFT SUPPORT, CAMSHAFT AND TAPPET BUCKET

Camshaft support

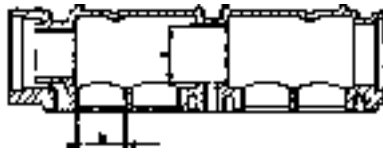

Unit: mm (in)

Inspection data		Engine		
		1200	1350	1500
Bore of camshaft journal bearing diameter "a"	Front	35.015 ÷ 35.040 (1.3786 ÷ 1.3795)		
	Central	46.500 ÷ 46.525 (1.8307 ÷ 1.8317)		
	Rear	47.000 G-47.025 (1.8504 ÷ 1.8514)		
Seat tappet bucket diameter "b"		36.000 ÷ 36.025 (1.4173 ÷ 1.4183)		

Camshaft

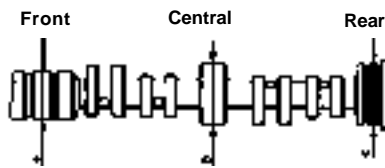

Unit: mm (in)

Inspection data		Engine		
		1200	1350	1500
Cam height	Intake Exhaust	8.5 (0.3346)		
Camshaft journal diameter	Front "a"	34.940 ÷ 34.956 (1.3756 ÷ 1.3762)		
	Central "b"	46.440 ÷ 46.456 (1.8283 ÷ 1.8290)		
	Rear "c"	46.940 ÷ 46.956 (1.8480 ÷ 1.8487)		

Tappet bucket

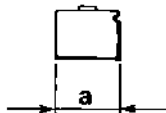

Unit: mm (in)

Inspection data		Engine		
		1200	1350	1500
Diameter "a"		35.973 ÷ 35.989 (1.4163 ÷ 1.4169)		

ENGINE MAIN MECHANICAL UNIT

CYLINDER HEAD, VALVES AND SPRINGS

Cylinder head

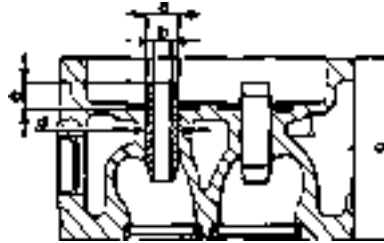

Unit: mm (in)

Inspection data		Engine		
		1200	1350	1500
Valve guide seat diameter "d"		13.000 ÷ 13.018 (0.5118 ÷ 0.5125)		
Valve guide 0.0. "a"	Standard	13.050 ÷ 13.068 (0.5138 ÷ 0.5145)		
	Spare	13.064 ÷ 13.082 (0.5143 ÷ 0.5150)		
Diameter of valve guide bore "b"		8.013 ÷ 8.031 (0.3155 ÷ 0.3162)		
Valve guide protrusion "e"		9.8 ÷ 10 (0.3858 ÷ 0.3937)		
Min. cylinder head thickness after resurfacing "c"		77.25 (3.04131 (1))		
Max. error of parallelism between head surfaces		0.05 (0.00201)		
Max. out of flat		0.03 (0.0012)		
Surface roughness		$1.6 \cdot 10^{-3}$ ($0.0630 \cdot 10^{-3}$)		

(1) Resurfacing of cylinder head with hemispherical combustion chamber must be done on both banks of the same engine

Valves

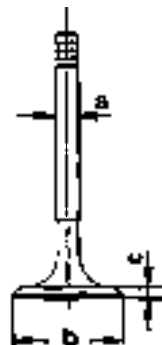

Unit: mm (in)

		Engine		
		1200	1350	1500
Valve stem diameter "a"	Intake	7.985 ÷ 8.000 (0.3144 ÷ 0.3150)		
	Exhaust	7.968 ÷ 7.983 (0.3137 ÷ 0.3143)		
Valve head diameter "b"	Intake	38.00 ÷ 38.20 (1.4961 ÷ 1.5040)		
	Exhaust	33.00 ÷ 33.20 (1.2992 ÷ 1.3071)		

ENGINE MAIN MECHANICAL UNIT

Springs

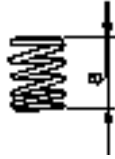

		Engine		
		1200	1350	1500
Length of valve spring with valve open "a"	mm (in)	25.25 (0.9941)		
		23.25 (0.9154)		
Spring rating at length "a"	N (kg) (lb)	425.32 ÷ 452.76 (43.4 ÷ 46.2) (95.68 ÷ 101.85)		
		194.53 ÷ 208.25 (19.85 ÷ 21.25) (43.76 ÷ 46.85)		

VALVE SEAT RECUTTING

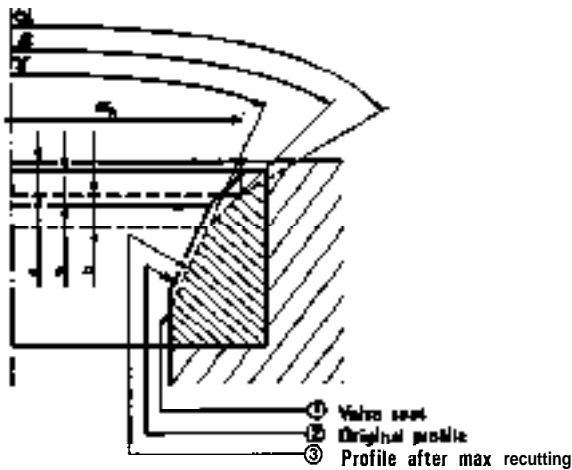

Unit: mm (in)

		Engine		
		1200	1350	1500
Reference diameter "Ø _R "	Intake	37.3 (1.4685)		
	Exhaust	31.9 (1.2559)		
Cut limit of valve seat top surface "a"		2.9 (0.1142)		
Cut limit of valve seat mating surface "b"	Intake	1.07 ÷ 1.37 (0.0421 ÷ 0.0539)		
	Exhaust	1.26 ÷ 1.56 (0.0496 ÷ 0.0614)		
Valve seat top surface limit angle "α"		120°		
Valve seat mating surface limit angle "β"		90° ÷ 90° 30		
Valve seat inner face limit angle "γ"	Intake	50°		
	Exhaust	30°		

ENGINE MAIN MECHANICAL UNIT

FITMENT PLAYS OR INTERFERENCE FITS

Unit: mm (in)

Inspection data		Engine			
		1200	1	1 3 5 0	1500
Cylinder bore/piston play	Standard Oversize	0.03 ÷ 0.05 (0.0012 ÷ 0.0020) 0.03 ÷ 0.06 (0.0012 ÷ 0.0024)			
Ring/groove end float	-First compression ring	0.035 ÷ 0.067 (0.0014 ÷ 0.0026)		0.035 ÷ 0.072 (0.0014 ÷ 0.0028) ⁽¹⁾ 0.035 ÷ 0.067 (0.0014 ÷ 0.0026) ⁽²⁾	0.035 ÷ 0.067 (0.0014 ÷ 0.0026)
	Second compression ring	0.035 ÷ 0.067 (0.0074 ÷ 0.0026)		0.035 ÷ 0.072 (0.0014 ÷ 0.0028) ⁽¹⁾ 0.035 ÷ 0.067 (0.0014 ÷ 0.0026) ⁽²⁾	0.036 ÷ 0.067 (0.0014 ÷ 0.0026)
	Oil scraper ring	0.025 ÷ 0.057 (0.0010 ÷ 0.0022)		0.025 ÷ 0.062 (0.0010 ÷ 0.0024) ⁽¹⁾ 0.025 ÷ 0.057 (0.0010 ÷ 0.0022) ⁽²⁾	0.025 ÷ 0.057 (0.0010 ÷ 0.0022)
	Maximum for each ring			0.1 (0.0039)	
Pin/small end play		0.007 ÷ 0.019 (0.0003 ÷ 0.0007)			
Pin/seat bore play	Standard Maximum	0.002 ÷ 0.010 (0.0001 ÷ 0.0004) 0.018 (0.0007)			
Main bearing to-journal play	Front and rear Central Maximum (with bearing in seat)	0.024 ÷ 0.065 (0.0009 ÷ 0.0026) 0.034 ÷ 0.075 (0.0013 ÷ 0.0030) 0.1 (0.0039)			
Connecting rod bearing-to-crankpin play	Standard	Red/Blue 0.034 ÷ 0.662 (0.0013 ÷ 0.0024)		Red/Blue 0.032 ÷ 0.064 (0.0013 ÷ 0.0025)	
	Maximum (with bearing in seat)	0.090 (0.0035)			
Crankshaft end float	Standard Max	0.056 ÷ 0.25 (0.0022 ÷ 0.0098) 0.35 (0.0138)			
End float of big end bearing	Standard Max	0.2 40.392 (0.0079 ÷ 0.0164) 0.45 (0.0177)			
Radial clearance between camshaft and bearing	Front	0.059 ÷ 0.100 (0.0023 ÷ 0.0039)			
	Central	0.044 ÷ 0.085 (0.0017 ÷ 0.0033)			
	Rear	0.044 ÷ 0.085 (0.0017 ÷ 0.0033)			
Camshaft end float		0.10 ÷ 0.33 (0.0039 ÷ 0.0130)			
Radial clearance between tappet bucket and seat in camshaft support	Standard	0.011 ÷ 0.052 (0.0004 ÷ 0.0020)			
	Max	0.1 (0.0039)			

ENGINE MAIN MECHANICAL UNIT

Inspection data			Engine		
			1200	1350	1500
Valve stem-to-guide play	Intake	Standard	0.013 ÷ 0.046 (0.0005 ÷ 0.0018)		
		Max	0.07 (0.0027)		
	Exhaust	Standard	0.030 ÷ 0.063 (0.0012 ÷ 0.0025)		
		Max	0.09 (0.0035)		
Valve guide-to-seat interference fit		Standard	0.032 ÷ 0.068 (0.0013 ÷ 0.0027)		
		Spare	0.046 ÷ 0.082 (0.0018 ÷ 0.0032)		

- (1) Borgo Piston
(2) Mondial Piston

TEMPERATURES

Part	Temperature
Oil pump/distributor drive gear for shrinking onto the crankshaft	150°C (302°F)

GENERAL SPECIFICATIONS

FLUIDS AND LUBRICANTS

Application	Type	Denomination	Q.ty kg (lb)
Engine oil when full	OIL	AGIP SINT 2000 10W50 Std.rd 3631-69352	3.15 (6.94)
Filter		IP Super Motor Oil 1 0W50 Std.rd 3631-69353	0.45 (0.99)
Engine oil and filter routine maintenance			3.6 (7.94)
Camshaft supports chests (1)			0.250 (0.55) (2) into each chest

- (1) Applicable only in the case of supports dismantling
(2) This quantity relates to chests supply, completely drain, up to drain holes level

SEALING COMPOUNDS

Application	Type	Denomination	Q.ty
Joint face, cylinder block-to-oil sump	CEMENT	DOW CORNING: Silastick 732 RTV Std. no. 3522-00040	---
Plugs of water galleries in cylinder block and head	CEMENT	LOCTITE 601 (green) Std. no. 3524-00011	---

- (1) Before applying LOCTITE, remove all traces of old Loctite and degrease threads using trichlorethylene or chlorothene

ENGINE MAIN MECHANICAL UNIT

- (1) After having heated engine until intervention of radiator cooling electric fan, on cold engine, loosen, oil and tighten the six screw securing head to base by following the order shown in figure

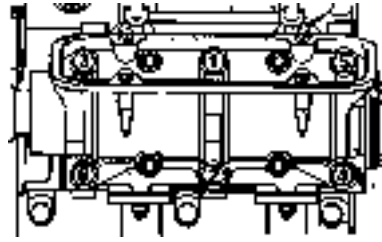

- (1) In the event of in-car tightening of head nuts with the aid of the extension A.5.0198 to be applied as shown, the torque specifications are:

torque spanner having a 300 mm (11.84 in) lever arm	<table style="width: 100%; border-collapse: collapse;"> <tbody> <tr> <td style="width: 15%;">N·m</td> <td style="width: 85%;">57 ÷ 62</td> </tr> <tr> <td>kg·m</td> <td>5.8 ÷ 6.3</td> </tr> <tr> <td>lb·ft</td> <td>41.9 ÷ 45.6</td> </tr> </tbody> </table>	N·m	57 ÷ 62	kg·m	5.8 ÷ 6.3	lb·ft	41.9 ÷ 45.6
N·m	57 ÷ 62						
kg·m	5.8 ÷ 6.3						
lb·ft	41.9 ÷ 45.6						
torque spanner having a 400 mm (15.75 in) lever arm	<table style="width: 100%; border-collapse: collapse;"> <tbody> <tr> <td style="width: 15%;">N·m</td> <td style="width: 85%;">62 ÷ 67</td> </tr> <tr> <td>kg·m</td> <td>6.3 ÷ 6.8</td> </tr> <tr> <td>lb·ft</td> <td>45.6 ÷ 49.2</td> </tr> </tbody> </table>	N·m	62 ÷ 67	kg·m	6.3 ÷ 6.8	lb·ft	45.6 ÷ 49.2
N·m	62 ÷ 67						
kg·m	6.3 ÷ 6.8						
lb·ft	45.6 ÷ 49.2						

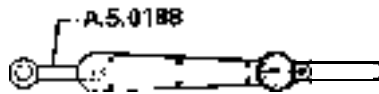







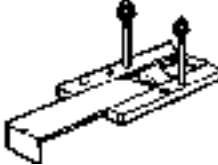

TROUBLE DIAGNOSIS AND CORRECTIONS

Condition	Probable cause	Corrective action
I. Noisy engine Knocking of crankshaft and bearing	Excessive crankshaft end play	Replace thrust bearing
Piston and connecting rod knocking	<ul style="list-style-type: none"> • Fit wrong • Pin float 	Adjust Adjust
Camshaft knocking	<ul style="list-style-type: none"> • Excessive valve play • Tappet buckets wrong fit • Weakened valve spring 	Adjust Replace Replace
Water pump knocking	Improper shaft end play	Replace water pump assembly
I I. Other mechanical trouble Seized valve seat	<ul style="list-style-type: none"> • Improper valve clearance • Weakened valve spring 	Replace and adjust Replace

ENGINE MAIN MECHANICAL UNIT

Condition	Probable cause	Corrective action
Excessively worn cylinder and piston	<ul style="list-style-type: none"> • Worn fit surfaces • Poor oil quality • Dirty air cleaner • Too rich mixture 	Adjust or replace User proper oil Replace filter Adjust or replace carburettor
Faulty connecting rod	<ul style="list-style-type: none"> • Shortage of engine oil • Poor engine oil quality • Worn or out-of-round crankpin • Wrong connecting rod bearing-to-crankpin coupling 	Add or replace oil Check oil level on daily basis Use proper oil Grind or replace Replace
Faulty crankshaft bearing	<ul style="list-style-type: none"> • Shortage of engine oil • Poor engine oil quality • Worn or out-of-round crankshaft journal • Wrong connecting rod bearing-to-crankpin coupling 	Add or replace oil Check oil level on daily basis Use proper oil Grind or replace Replace
Belt tensioner knocking	Wrong belt stretching	Restore stretch
Faulty timed	Wear of oil pump control gear	Replace
III. Lubrication oil leakage	<ul style="list-style-type: none"> • Loosen engine oil drain plug • Oil leakage from sump gasket • Oil leakage from camshaft supports gasket • Oil leakage from engine gaskets and seal rings • Oil leakage from oil filter gasket 	Tighten Replace gasket Replace gasket Replace gasket Screw in filter
Decreased of pressure	<ul style="list-style-type: none"> • Dirty pressure regulator valve • Poor-engine oil quality 	Clean Replace

SPECIAL SERVICE TOOLS

Tool number	Tool name	Refer to page
A.2.0195	Base for cylinder head support 	01-17 01-19 01-24
A.2.0226	Yoke for cylinder head support 	01-17 01-19 01-24
A.2.0378	Tool for locking the flywheel 	01-15
A.3.0103/6	Yoke to remove and refit valves 	01-17 01-24
A.3.0311	Puller of valve guides 	01-18
A.3.0312	Driver of intake valve guides 	01-18
A.3.0314	Driver of timing gear cover Seal 	01-24
A.3.0321	Support for removing and fitting valves 	01-17 01-24
A.3.0324	Lever for removing and refitting the valves 	01-17 01-24

AIR CLEANER

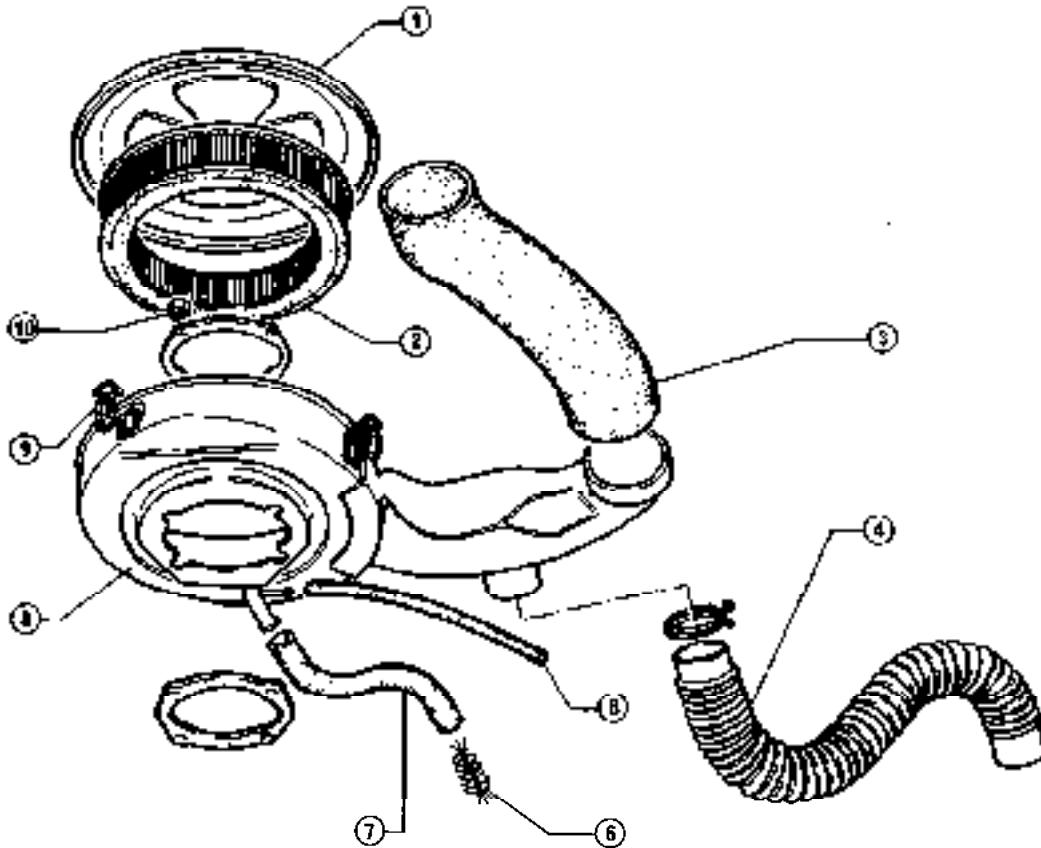

- | | |
|--------------------------|---------------------|
| 1 Cover | 6 Flame trap |
| 2 Cartridge | 7 Max. blow-by hose |
| 3 Cool air intake sleeve | 8 Air cleaner body |
| 4 Hot air intake sleeve | 9 Spring clip |
| 5 Min. blow-by hose | 10 Nut |

REMOVAL

Remove air cleaner body with carriage cartridge as follows:

1. Unfasten the five spring clips (9) that secure cover (1) to air cleaner body (8); remove cover.
2. Remove cartridge (2).
3. Disconnect cool air intake sleeve (3) as well as hot air intake sleeve (4).
4. Disconnect blow-by hoses (5) a and (7).

5. if necessary, remove flame trap (6) from max. blow-by hose@.

6. Loosen the four nuts (10) securing air cleaner body to carburetor; remove air cleaner body.

CHECKS AND INSPECTIONS

1. Thoroughly clean cartridge by blowing low pressure compressed air

from within; if necessary, replace it.
 2. Remove flame trap from blow-by hose, wash both with specific products, then dry them with compressed air. Install flame trap into blow-by hose near oil filler.

INSTALLATION

Fit air cleaner, blow-by hoses and air intake sleeves back together following removal procedure in reverse sequence.

IDLE COMPENSATOR

DESCRIPTION

The idle compensator actually consists of a thermostat (1) that checks the temperature of the engine intake air and as a consequence either opens or closes the throttle valve (4) located in the air cleaner's intake duct. The throttle valve mixes the cool air coming from outside with that coming from the hot air intake, located on the exhaust gas pipes under the left side cylinder head, or it works either fully closed or fully open.



- 1 Thermostat
- 2 Hot air intake sleeve
- 3 Cool air intake sleeve
- 4 Throttle valve
- 5 Air cleaner

CHECKS AND INSPECTIONS

HOT AIR INTAKE CLOSING TEMPERATURE

1. Warm up engine bringing it up to steady running.
2. Turn engine off.
3. Remove air cleaner cover as well as cartridge.
4. Inset-t a thermometer next to the thermostat inside the air cleaner.
5. When thermometer shows specified temperature, verify thermostat commands, i.e. opening of throttle valve thus fully closing the hot air intake.

Hot air intake closing temperature
33 ÷ 37°C (91.4 ÷ 98.6°F)

COOL AIR INTAKE CLOSING TEMPERATURE

1. With cold engine, remove air cleaner cover as well as cartridge.
2. Insert a thermometer next to the thermostat inside the air cleaner.

3. When thermometer shows specified temperature, verify thermostat commands, i.e. closing of throttle valve thus fully closing the cool air intake.

Cool air intake closing temperature
28 ÷ 32°C (82.4 ÷ 89.6°F)

THERMOSTAT REPLACEMENT

1. Remove air cleaner from engine (Refer to: Air Cleaner).
2. Remove rivets securing air intake to air cleaner body.
3. Replace air intake as well as thermostat.
4. Connect air intake back to air cleaner body by riveting it.
5. Fit air cleaner back to engine (refer to: Air Cleaner).

CHECKS AND INSPECTIONS

CAUTION:

When disconnecting fuel system hoses, use a container with safety lid to collect the petrol that is left over in the hoses.

FUEL PUMP DELIVERY PRESSURE

1. Disconnect fuel delivery hose from pump and from carburetor.
2. Replace same with a T-shaped hose equipped with cutoff cocks.
3. Connect a pressure gauge to the hose's free end.
4. Start engine up and with zero delivery (cock on carburetor side is closed), while keeping gauge at same height as pump, verify that gauge

reading is within specified values at relevant engine rpm.

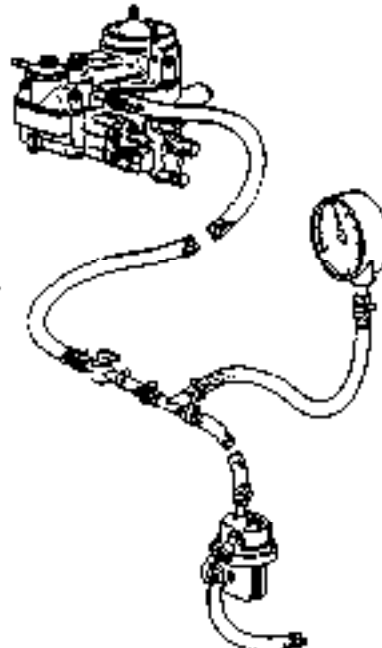

FUEL PUMP PRESSURE

FISPA P u m p
17.7 ÷ 29.4 KPa
(0.177 ÷ 0.294 bar, at 5000 rpm
0.18 ÷ 0.30 kg/cm²,
2.56 ÷ 4.27 psi)

SAVARA Pump
17.7 ÷ 29.4 KPa
(0.177 ÷ 0.294 bar, at 6000 rpm
0.18 ÷ 0.30 kg/cm²,
2.56 ÷ 4.27 psi)

5. If delivery pressure is not within specified values, replace the pump.
6. Disconnect T-shaped hose and restore normal operating conditions.

CARBURETORS

WEBER TWIN CARBURETOR

(Except Switzerland, Sweden, Australia.)

- 32 DIR 51A/250 for 1200 model
- 32 DIR 81A/250 for 1350 model
- 32 DIR 71A/250 for 1500 model

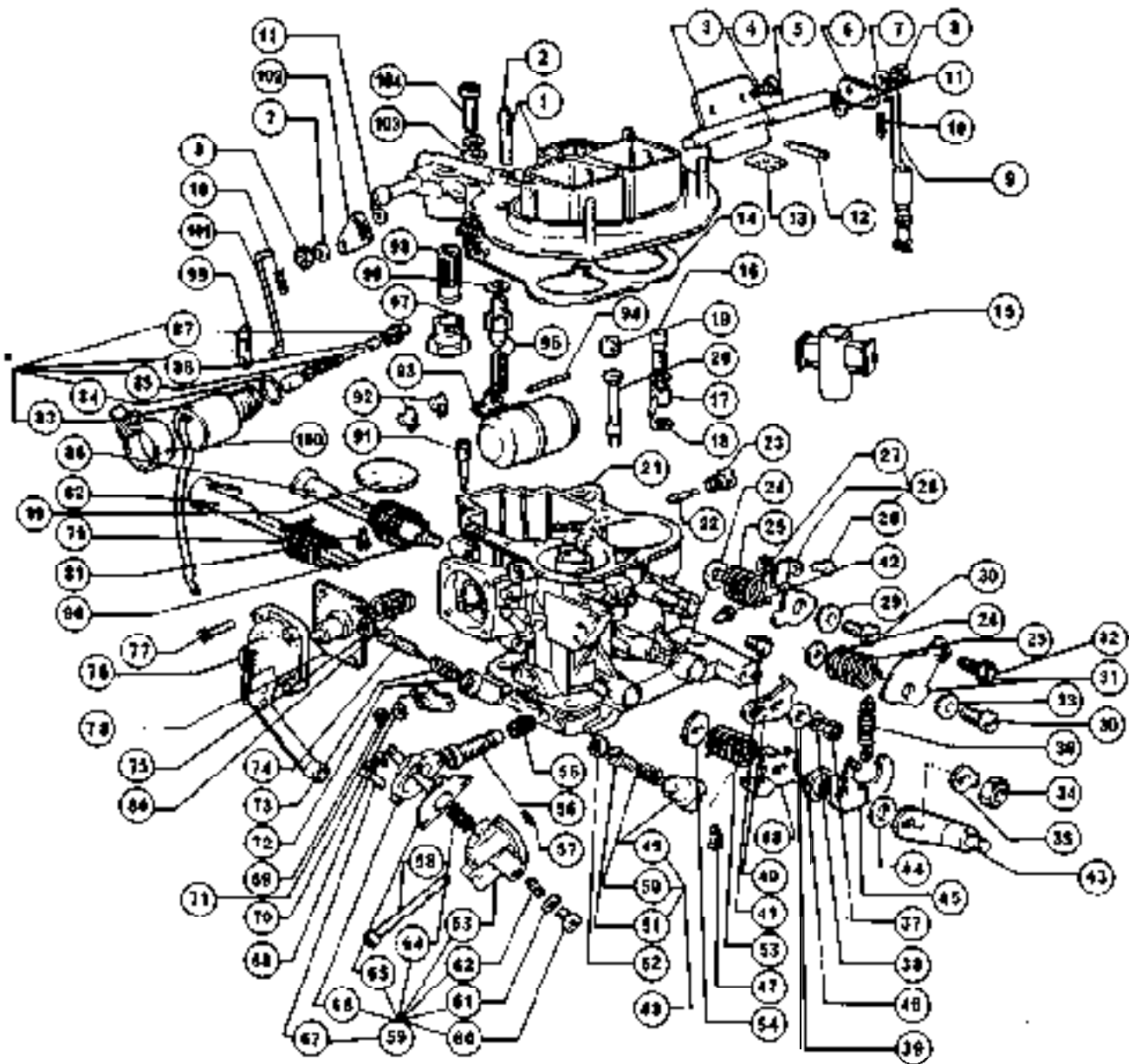

* For 32 DIR 81A/250 and 32 DIR 71A/250 only

FUEL SYSTEM

- | | | |
|-------------------------------------------------------------------------------------------------------------------------------------------------------------------------------------------------------------------------------------------------------------------------------------------------------------------------------------------------------------------------------------------------------------------------------------------------------------------------------------------------------------------------------------------------------------------------------------------------------------------------------------------------------------------------------------------------------------------------------------------------------------------------------------------------------------------------------------------------------------------------------------------------------------------------------------------------------------------------------------------------------------------------------------------------------------------------------------------------------------------------------------------------------------------------------------------------------------------------------------------------------------------------------------------------------------------------------------------------------|---------------------------------------------------------------------------------------------------------------------------------------------------------------------------------------------------------------------------------------------------------------------------------------------------------------------------------------------------------------------------------------------------------------------------------------------------------------------------------------------------------------------------------------------------------------------------------------------------------------------------------------------------------------------------------------------------------------------------------------------------------------------------------------------------------------------------------------------------------------------------------------------------------------------------------------------------------------------------------------------------------------------------------------------------------------------------------------------------------------------------------------------------------------------------------------------------------------------------------------------------------------------------------------------------------------------------------------------------------------------------------------------------------------------------------|------------------------------------------------------------------------------------------------------------------------------------------------------------------------------------------------------------------------------------------------------------------------------------------------------------------------------------------------------------------------------------------------------------------------------------------------------------------------------------------------------------------------------------------------------------------------------------------------------------------------------------------------------------------------------------------------------------------------------------------------------------------------------------------------------------------------------------------------------------------------------------------------------------------------------------------------------------------------------------------------------------------------------------------------------------------------------------------------------------------------------------------------------------------------------------------------------------------------------------------------------------------------------------------|
| <ul style="list-style-type: none"> 1 Carburetor cover including: 2 -Stud 3 Starting throttle 4 Starting securing screw 5 Starting shaft 6 Lever for starting shaft 7 Corrugated washer 8 Starting shaft lever securing nut 9 Starting control tie rod 10 Tie rod split pin 11 Tie rod washer 12 Dust cover cap 13 Dust cover plate 14 Carburetor cover gasket 15 Primary auxiliary Venturi 15 Secondary auxiliary Venturi 16 Pump delivery valve 17 Pump jet 18 Pump jet gasket 19 Primary corrector jet 19 Secondary corrector jet 20 Primary emulsifying tube 20 Secondary emulsifying tube 21 Carburetor body 22 Secondary idling jet 23 Secondary idling jet carrier 24 Shim adjustment washer 25 Lever return spring 26 Fast idling regulation lever together with: 27 - Nut 28 - Adjustment screw 29 Bush for fast idling regulation lever 30 Lever securing screw 31 Starting control lever together with: 32 Cable securing screw 33 Bush for starting control lever 34 Shaft securing nut | <ul style="list-style-type: none"> 35 Safety washer 36 Spring for loosen lever 37 Secondary shaft securing nut 38 Spring washer 39 Shim adjustment washer 40 Secondary throttle control lever 41 Sheath securing screw 42 Cap for secondary idling hole 43 Throttle control lever 44 Shim 45 Loosen lever 46 Bush for loosen lever 47 Secondary throttle adjustment screw 48 Stop lever together with: 49 - Bush for sealed idling cap 50 - Spring 51 Adjustment screw 52 Sealed cap for lever adjustment screw 53 Primary shaft return spring 54 Shim adjustment washer 55 Spring for adjustment screw of corrector idling 56 Adjustment screw for idling mixture corrector 57 Gasket for de-flood device 58 Securing screw for de-flood device 59 Economiser body including: 60 Cap for adjustment screw 61 Spring washer 62 - Diaphragm adjustment screw 63 - Device box 64 - Spring for diaphragm 65 - Diaphragm 66 - Device cover 67 - Cover securing screw 68 Retaining ring 69 Retaining ring 70 Washer for economiser body control lever 71 Economiser control lever | <ul style="list-style-type: none"> 72 Bush for sealed idling cap 73 Adjustment screw cap 74 Idling mixture adjustment screw 75 Sealed idling cap 76 Pump cover 77 Pump cover securing screw 78 Pump diaphragm 79 Primary shaft return spring 80 Pump filling spring 81 Throttles securing screw 82 Primary main shaft 82 Oversize primary main shaft 83 * Idling cut-off together with: 84 - Gasket 85 Conic seal needle 86 Bush 87 - Primary idling jet 88 Secondary main shaft 88 Oversize secondary main shaft 89 Throttle valve 90 Secondary shaft return spring 91 Closing screw for pump discharge space 92 Primary main jet 92 Secondary main jet 93 Float 94 Float fulcrum pin 95 Needle valve 96 Needle valve gasket 97 Filter inspection cap 98 Filter 99 Tie rod spring 100 *Cut-off clamp 101 Economiser body control tie rod 102 Economiser control lever 103 Washer for cover securing screw 104 Carburetor cover securing screw |
|-------------------------------------------------------------------------------------------------------------------------------------------------------------------------------------------------------------------------------------------------------------------------------------------------------------------------------------------------------------------------------------------------------------------------------------------------------------------------------------------------------------------------------------------------------------------------------------------------------------------------------------------------------------------------------------------------------------------------------------------------------------------------------------------------------------------------------------------------------------------------------------------------------------------------------------------------------------------------------------------------------------------------------------------------------------------------------------------------------------------------------------------------------------------------------------------------------------------------------------------------------------------------------------------------------------------------------------------------------|---------------------------------------------------------------------------------------------------------------------------------------------------------------------------------------------------------------------------------------------------------------------------------------------------------------------------------------------------------------------------------------------------------------------------------------------------------------------------------------------------------------------------------------------------------------------------------------------------------------------------------------------------------------------------------------------------------------------------------------------------------------------------------------------------------------------------------------------------------------------------------------------------------------------------------------------------------------------------------------------------------------------------------------------------------------------------------------------------------------------------------------------------------------------------------------------------------------------------------------------------------------------------------------------------------------------------------------------------------------------------------------------------------------------------------|------------------------------------------------------------------------------------------------------------------------------------------------------------------------------------------------------------------------------------------------------------------------------------------------------------------------------------------------------------------------------------------------------------------------------------------------------------------------------------------------------------------------------------------------------------------------------------------------------------------------------------------------------------------------------------------------------------------------------------------------------------------------------------------------------------------------------------------------------------------------------------------------------------------------------------------------------------------------------------------------------------------------------------------------------------------------------------------------------------------------------------------------------------------------------------------------------------------------------------------------------------------------------------------|

* Only for 32 DIR 8 1 A/250 and 32 DIR 7 1 A/250

CHECKS AND INSPECTIONS

Before removing carburetor from engine, perform following checking and adjusting operations:

1. Float leveling

Check float position as follows:

(1) Remove the whole air filter (see Air Cleaner) and disconnect the gasoline feeding hose from float chamber cover.

(2) Remove float chamber cover (4).

(3) Make sure float (2) is of the weight prescribed in the technical data, that no deformation is present and that it freely rotates on its pin.

(4) If checked parts are defective, replace them.

(5) Keep float chamber cover (4) in vertical position so as that float is slightly in touch on needle valve, which is of the spring-body type. Using a gauge pin, check if float

distance from float chamber cover - with gasket (3) firmly in place - is within specified "QW" value.

"QW" Dimension

6.75 ÷ 7.25 mm (0.266 ÷ 0.285 in)

(6) To correct "QW" dimension, suitably bend float stopper (1).

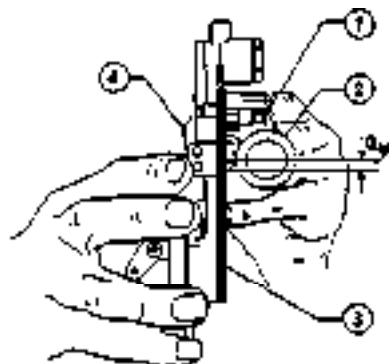

- | | |
|-----------------|-----------------------|
| 1 Float stopper | 4 Float chamber cover |
| 2 Float | |
| 3 Gasket | |

2. Needle valve tightness

Needle valve tightness is checked by means of a vacuum gauge. Keep float chamber cover turned over and in horizontal position and then proceed as follows:

(1) Connect gauge's plastic hose (2) to petrol delivery pipe (1) on float chamber cover.

(2) Load vacuum gauge air pump by acting on cam (3); as a consequence, mercury will go up the graduated scale.

(3) Wait for about ten seconds, during which mercury will have to remain steady, contraywise, replace needle valve.

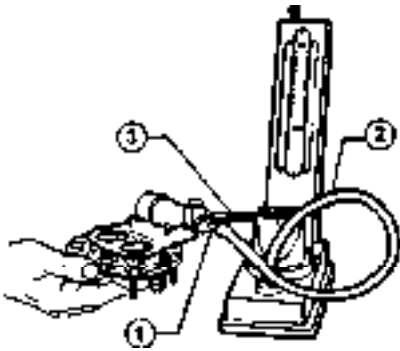

1 Petrol delivery pipe
2 Connecting hose
3 Cam

Remove carburetor from car in order to carry out the following checks (refer to: Group 01 Engine Disassembly - Engine Unit).

1. Choke opening (air valve) by economiser

To adjust choke (1) opening proceed as follows:

- (1) Fully engage choke by moving starting control lever (2) as shown in relevant figure and at the same time act on the economiser control lever pushing it all the way back.
- (2) Insert gauged point between choke edge and duct making sure dimension "G_{W1}" is within specified value.

"G_{W1}" Dimension
5.5 ÷ 6.5 mm (0.216 ÷ 0.256 in)

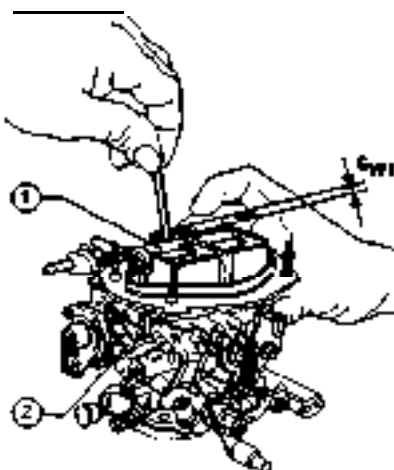

1 Choke air valve
2 Choke control lever

- (3) In case the verified dimension "G_{W1}" is not within specified value, remove cap and operate on travel adjustment screw of economiser diaphragm (see following figure).
- (4) At the end of adjustment operation, refit cap (1).

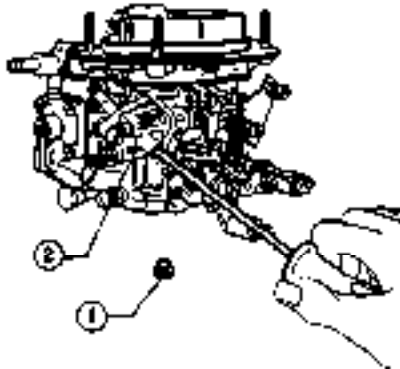

1 Cap
2 Economiser body

2. Throttle valve opening (gas valve) with choke inserted.

To adjust throttle valve (1) opening proceed as follows:

- (1) Fully engage choke by moving starting control lever (2) as shown in relevant figure.
- (2) Insert a gauged wire between throttle valve edge and first body duct making sure dimension "G_{W2}" is within specified value.

"G_{W2}" Dimension
0.9 ÷ 1 mm (0.035 ÷ 0.039 in)

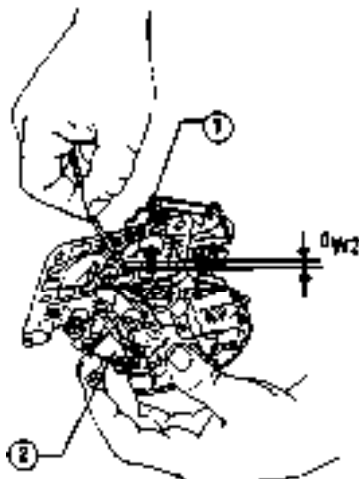

1 Throttle valve
2 Starting control lever

- (3) If "G_{W2}" dimension is not within specified value, loosen the nut and operate on control lever adjustment screw of throttle valve (see next figure).

- (4) Having completed adjusting operations, tighten the nut.

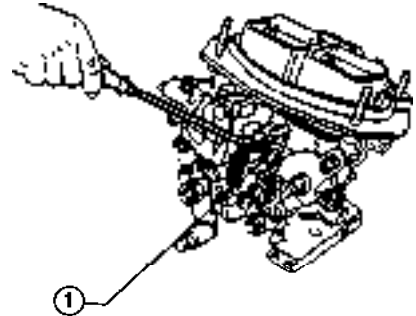

1 Nut

3. Accelerator pump adjustment

Adjust accelerator pump as follows:

- (1) Secure carburetor to support C.4.0103 (fitted with gasket) of the pump test instrument C.4.0101.
- (2) Supply the carburetor with petrol by connecting it to the tools reservoir.
- (3) Set the graduated measuring tubes C.4.0105 under the foreseen exhaust pipe -on support itself.
- (4) Carry out twenty strokes corresponding to as many complete openings and closings of throttle valve, operating on control lever (2).
- (5) Check if volume of petrol collected in the measuring tube corresponds to specified "V_W" value.

When pumping, briefly stop both in throttle valve fully open and fully closed positions.

Volume of petrol "V_W" corresponding to 20 strokes of pump control lever:

$$"V_W" = 17 \div 20 \text{ cm}^3$$

$$(1.03 \div 1.22 \text{ cu.in.})$$

- (6) If "V_W" value is not within specified limit, check diaphragm of acceleration pump and the pump jet.

WEBER TWIN CARBURETOR

For Switzerland, Sweden, Australia.

Carry out checks and adjustments following the procedures performed for the WEBER twin carburetors, previously described and referring to the tables provided in "Technical Data and Specifications" relevant to check dimensions.

WEBER TWIN CARBURETOR -- EXPLODED VIEW

(it will be provided in the next issue)

FUEL SYSTEM

KEY

(it will be provided in the next issue)

FUEL SYSTEM

- 58 Central Venturi securing screw
- 59 Sheath securing screw
- 60 Air valve control intermediate lever
- 61 Air valve control return lever
- 62 Bush
- 63 Air valve automatic opening control lever
- 64 Securing nut
- 65 Washer

- 66 Sheath support
- 67 Washer
- 68 Support securing screw
- 69 Bush
- 70 Central Venturi
- 71 Economiser gasket
- 72 Economiser assy

- 73 Air valve spring
- 74 Idling cut-off
- 75 Air valve
- 76 Air valve control tie rod
- 77 Air valve shaft assy
- 78 Air valve securing screw
- 79 Stud

CHECKS AND ADJUSTMENTS

Before removing carburetor from engine, carry out the following checks.

1. Check of float chamber hydraulic level

For float chamber hydraulic level check, operate as follows:

- (1) Remove the whole air filter (see: Air cleaner) and disconnect the fuel feeding hose from float chamber cover.
- (2) Remove float chamber cover
- (3) Make sure that float is of the prescribed weight indicated in the Technical Data, that no deformation is present and that it freely rotates around its pin.
- (4) If checked parts are defective, replace them.
- (5) Verify that value of distance "A" between fuel surface and float chamber cover surface with assembled gasket, is within specified value.

$$A = 21 \div 23 \text{ mm } (0.83 \div 0.91 \text{ in})$$

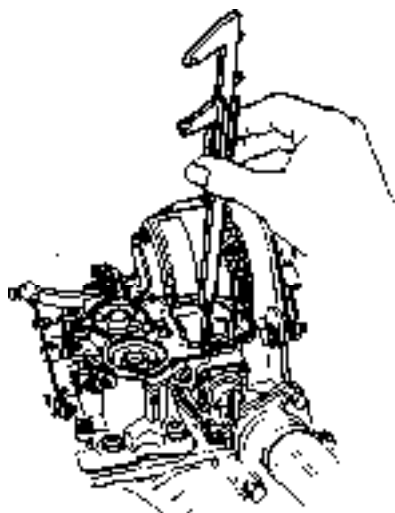

- (6) To correct "A" dimension, replace washer located under needle valve of properly bend float stopper.
- (7) Reassembly carburetor cover, let the engine executes a few rotations then repeat check operations until the prescribed dimension is obtained.

2. Needle valve tightness
- To check needle valve tightness, see Weber twin carburetor: Checks and Inspections - Needle Valve Tightness.

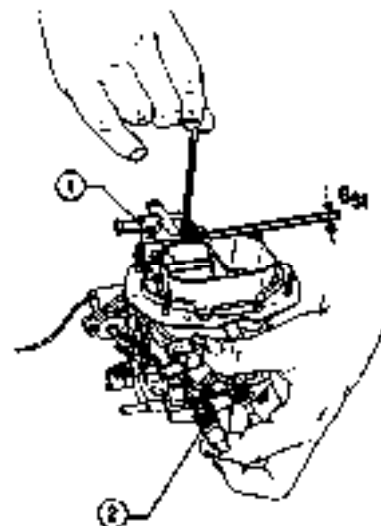
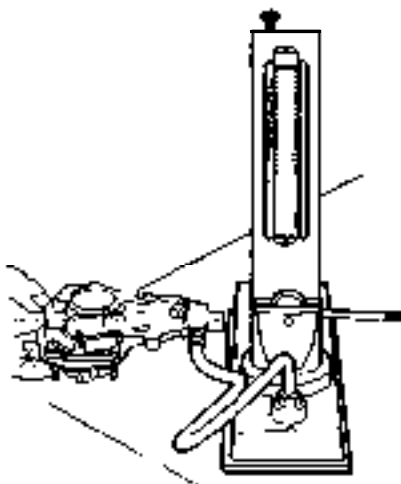

- 1 Choke (air valve)
- 2 Starting control lever

- (3) In case the verified dimension "G_{S1}" is not within specified valve loosen lock-nut and operate on diaphragm travel adjustment nut of economiser body ① (see next figure).

- (4) At end of adjustment, tighten lock-nut.

Remove carburetor from car in order to carry out the following checks (see: Group 01 - Engine Disassemble - Engine Unit).

1. Choke opening by economiser.
- To adjust choke ① opening proceed as follows:

- (1) Fully engage choke by moving starting control lever ② as shown in relevant figure and at the same time act on the economiser control lever pushing it all the way back.
- (2) Insert gauged point between choke edge and duct making sure dimension "G_{S1}" is within specified value.

"G_{S1}" Dimension
4.5 ÷ 4.75 mm (0.177 ÷ 0.187 in)

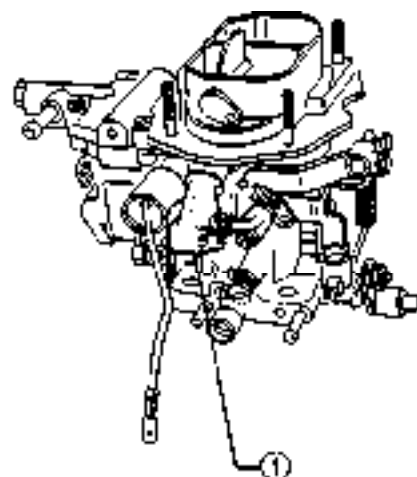

- 1 Economiser body

FUEL SYSTEM

2. Throttle valve opening (gas valve) with volet inserted.

To adjust throttle valve ① opening proceed as follows:

(1) Fully engage choke as shown in figure.

(2) Insert a gauged wire between throttle valve edge and the first body duct making sure dimension "G_{S2}" is within specified value.

"G_{S2}" Dimension
0.9 ÷ 1 mm (0.035 ÷ 0.039 in)

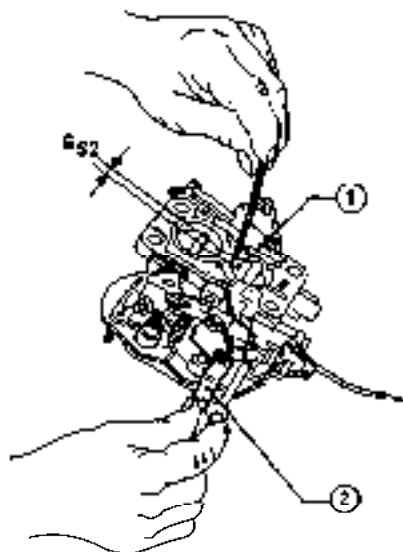

1 Throttle valve
2 Starting control lever

(3) If "G_{S2}" dimension is not within specified value loose nut and operate on control lever adjustment screw of throttle valve (see next figure).

(4) Having completed adjusting operations, tighten the nut.

3. Accelerator pump adjustment
To check and adjust accelerator pump refer to: Weber Twin Carburetor: Checks and Inspections - Accelerator Pump).

Volume of petrol "V_S" corresponding to 20 strokes of pump control lever:

Twin carburetor Solex C32 EIES 45

1st barrel	cm ³	8 ÷ 10
	(in)	(0.49 ÷ 0.61)
2nd barrel	cm ³	8 ÷ 10
	(in)	(0.49 ÷ 0.61)
Total	cm ³	16 ÷ 20
	(in)	(0.97 ÷ 1.22)

Twin carburetor Solex C32 EIES 44

1st barrel	cm ³	8 ÷ 10
	(in)	(0.49 ÷ 0.61)
2nd barrel	cm ³	9 ÷ 11
	(in)	(0.55 ÷ 0.67)
Total	cm ³	17 ÷ 21
	(in)	(1.04 ÷ 1.28)

Twin carburetor Solex C32 EIES 43

1st barrel	cm ³	8 ÷ 10
	(in)	(0.49 ÷ 0.61)
2nd barrel	cm ³	10 ÷ 12
	(in)	(0.61 ÷ 0.77)
Total	cm ³	18 ÷ 22
	(in)	(1.10 ÷ 1.34)

Fit carburetor back to engine (refer to Group 01 - Engine Assembly - Engine Unit) tightening relevant nuts according to specified torque and performing idle adjustment (refer to: Group 00 - Engine Maintenance).

Ⓣ : Tightening Torque
Carburetor retaining nuts
19 ÷ 23.5 N·m
(1.9 ÷ 2.4 kg·m)
13.74 ÷ 17.35 ft·lb)

OVERHAULING

Carburetor should be overhauled only if encountered defects cannot be corrected neither through operations described in Checks and Inspections above nor through cleaning of fuel filter, float chamber or jets. When overhauling, keep following items in mind:

a. Remove carburetor from engine and disassemble it on bench.

All disassembled parts must be thoroughly cleaned.

b. Thoroughly and carefully check most delicate parts such as needle valve, throttle valve shafts, diaphragms, accelerator pump and fuel filter.

c. Replace defective parts only with original ones and always replace all gaskets.

d. Use special care in cleaning jets so as not to damage relevant ratings; if possible blow them with a jet of compressed air.

CAUTION:

Once carburetor has been overhauled, it is advisable to perform adjustments described in preceding paragraph "Checks and Inspections".

ACCELERATOR CABLE ADJUSTMENT

1. Verify that throttle valve control cable can freely slide inside sheath.

2. Verify that clearance between clevis slot ④ and pin ③ on carburetor throttle valve opening shaft is within specified G₁ limit.

Clevis slot to pin clearance
G₁ = 1 mm (0.039 in)

3. If required, adjust as follows:

(1) Loosen adjusting screws ① lock nut ②.

(2) Turn screw ① till specified clearance is reached.

(3) Tighten lock nut.

CAUTION:

To easy adjustment buck action of return spring by manually partially opening the throttle valve.

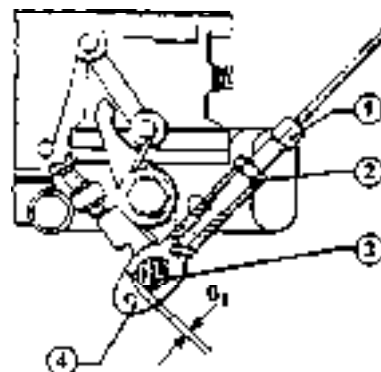

1 Adjusting screw 3 Pin
2 Lock nut 4 Clevis

REMOVAL

WARNING:

Before replacing any fuel line part, carefully follow below instructions:

- a. Make sure shop is equipped with suitable safety equipment.
- b. Disconnect battery ground cable.
- c. Place petrol drained from tank into a suitable container equipped with a safety lid.

FUEL TANK UNIT

1. Remove filler cap from filler hose and take out all petrol from tank with the help of a suitable pump.
2. Loosen clamp (2) and (3) connecting fuel filling sleeve to tank and connecting pipe to feeding hose.
3. Loosen and remove screw securing ground cable (1) to body.

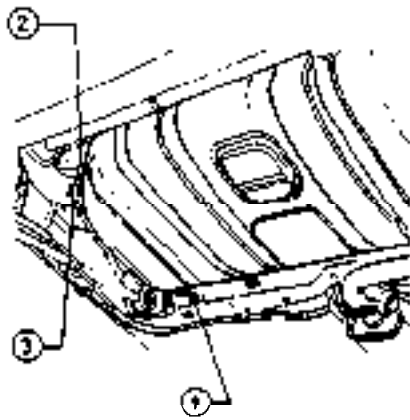

1 Ground cable 3 Clamp
2 Clamp

4. Support tank by means of column lift and loosen screws securing the clamps supporting tank to body.
5. Slowly lower column lift so as to gain access to tank upper side.
6. Remove from float the electric connections of warning lamp and indicator of fuel level, then, operating from tank rear side, remove breather pipe together with retaining valve.
7. Remove tank and, if required disassemble it.

FUEL TANK FLOAT

Remove float of fuel tank operating as follows:

1. Support tank by means of column lift and loosen screws securing the two clamps supporting tank to body.
2. Slightly lower column lift so as to gain access to float located on tank upper side.
3. Disconnect from pipe union, on float, the fuel delivery pipe (3) and remove electric connections (2) of warning lamp and fuel level indicator.
4. Loosen the six screws securing float (1) to tank and remove float.

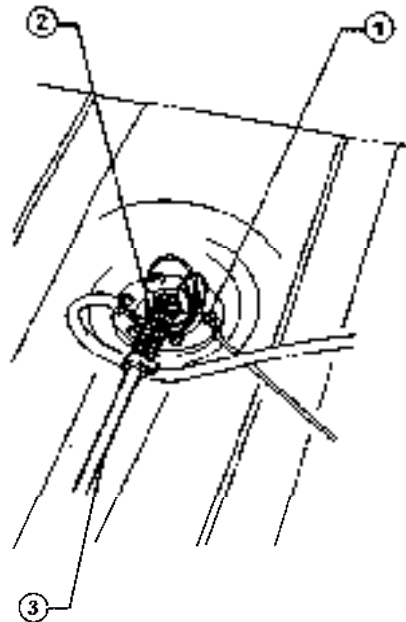

1 Float securing screw
2 Electric connections
3 Fuel delivery pipe

FUEL LINE

CAUTION:

Disconnect feedings pipes only if absolutely necessary.

1. Remove filler cap and take out all petrol from tank with the help of a suitable pump.
2. Remove clamps from hose unions; plug all hoses and pipes to prevent dust or dirt from going in during disassembly operations.
3. Free pipes from relevant holding clamps on underbody.

CHECK VALVE

Remove check valve from supporting clip on fuel tank.

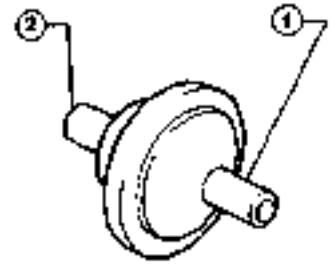

1 Tank pipe side union
2 Outer side union

CHECKS AND INSPECTIONS

TANK

Check tank for flaws or any evidence of warpage; if necessary, replace it.

HOSES

Check hoses and make sure they are not porous and show no evidence of abnormal wear; replace hoses that are not flawless.

PIPES

Check and make sure pipes are not clogged, oxidized or dented.

CHECK VALVE

1. Blow in an air into the valve located of fuel pipe side. In doing so, one should notice some resistance and some air should come out of the outer union.
2. Now blow in an air jet into the valve from outer side union. The air jet should go right through and come out of the fuel pipe side union, without encountering any resistance.
3. If check valve does not comply with above, replace it.

INSTALLATION

Carefully fit all fuel line parts back together following removal operations in reverse sequence and paying special attention to below instructions.

FUEL SYSTEM

CAUTION:

- Carefully fit clamps back to line unions without tightening them too much to avoid damaging the hoses.
- Fit fuel delivery pipes securely to relevant holding clamps on underbody, making sure same are properly fastened.
Failure to follow this caution will result in damage to pipe

- surfaces.
- Do not bend or twist pipes during installation.
- Start engine up and make sure there are no leaks from connections.

FUEL TANK UNIT

- Fit tank back into car following removal operations in reverse sequence.

- Do not twist or crush breather hoses after fitting; fasten them with relevant clamps.

FLOAT

Be sure to replace the gasket each time float is fitted back into tank.

CHECK VALVE

Be sure to fit check valve according to proper working direction.

EXHAUST SYSTEM

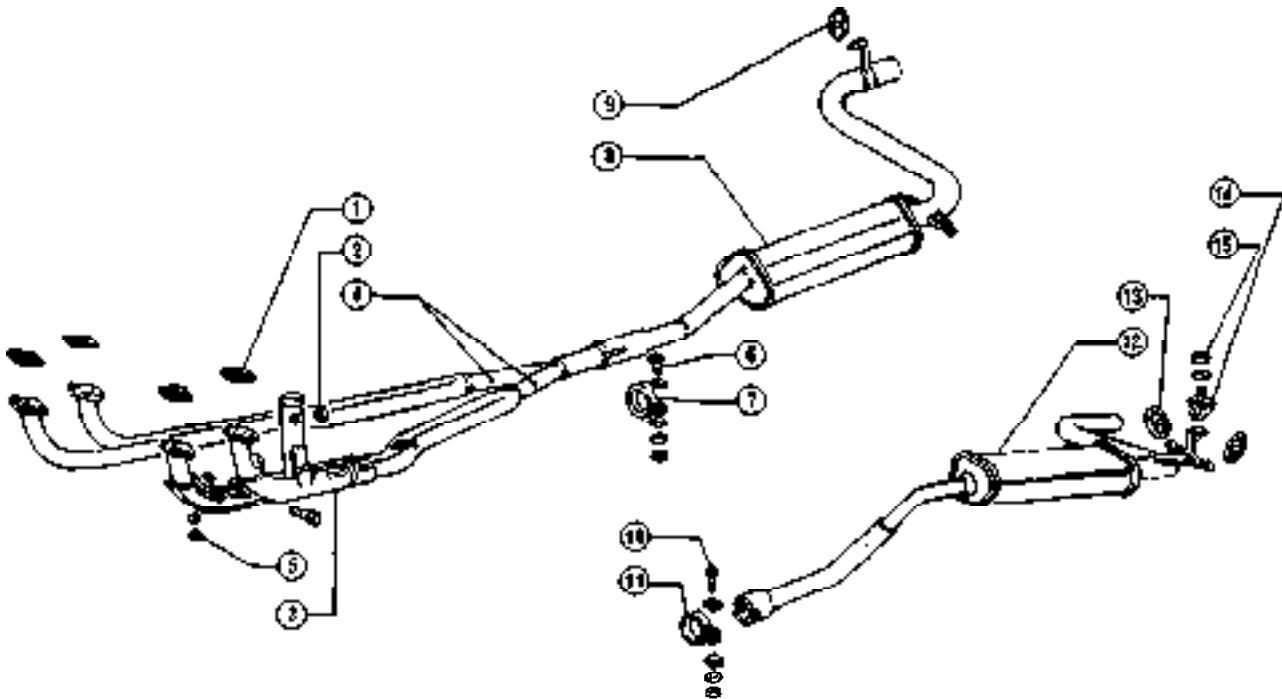

- Gasket
- Nut
- Hot air intake
- Front manifolds
- Nuts

- Bolt
- Front clamp
- Central muffler
- Support ring
- Bolt

- Rear clamp
- Rear muffler
- Support ring
- Buffer
- Nut

CHECKS AND INSPECTIONS

- Check mufflers and exhaust pipes making sure they are not in any way damaged or cracked and show no evidence of corrosion; contrarywise, replace them.
- Thoroughly check supports ring and do not hesitate to replace them if they are cracked, porous or worn.

- Check buffer on exhaust pipe end.
- Check surface of hot air intake making sure there are no warps or dents that could impair normal air flow.

REMOVAL

- Instructions hereafter described have been compiled so as to

allow separate removal of the exhaust system's single components.

- Consequently, removal procedure may be changed depending on the operation's purpose.
- When removing the entire exhaust system, it is advisable to get someone to help you with it.

FUEL SYSTEM

MANIFOLDS AND MUFFLERS

Referring to the figure on page 04-16, proceed with removal as follows:

1. Raise car on lift.
2. Remove rear muffler as follows:
 - (1) Loosen clamp (1) connecting central element with rear one and release this one from support retaining rings (13).
 - (2) With a suitable hammer, lightly and repeatedly strike all around the muffler pipes connection area and then alternately turn muffler (12) clockwise and counterclockwise so as to make separation easier.

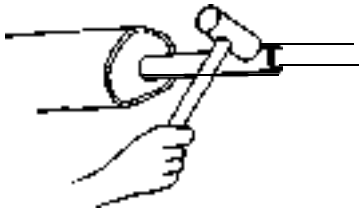

(3) If necessary, use a plastic hammer and lightly strike the muffler in the direction of removal till rear muffler comes off the central muffler.

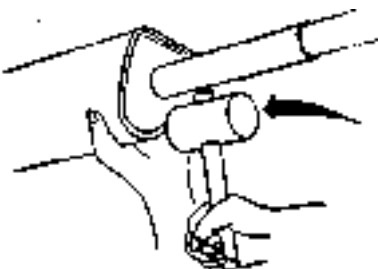

3. Remove central muffler as follows:

- (1) Remove rear muffler (refer to item 2 above).
- (2) Loosen clamps connecting central element with front one and disconnect central element from support retaining rings (9).
- (3) With a suitable hammer, lightly and repeatedly strike all around the pipes connection area and then alternately turn muffler (8) clockwise and counterclockwise so as to make separation easier.
- (4) If necessary, use a plastic hammer and lightly strike the muffler in the direction of removal till central muffler comes off front manifolds.

4. Remove front manifolds as follows:

- (1) Loosen clamp connecting front element to central one and move it from its seat.
- (2) Loosen the nut securing hot air intake bracket to cylinder head and withdraw the warm air intake sleeve.
- (3) Loosen nut (5) securing manifold flanges to cylinder heads.
- (4) Remove manifolds (4).

SUPPORT RINGS

Verify integrity of support rings and replace them if necessary.

HOT AIR INTAKE

1. Raise car on lift.
2. Withdraw sleeve (1) from air intake (2).
3. Loosen bolt (5) connecting air intake to manifolds and then remove clamp (4) thus separating the hot air intake half shells.
4. Loosen nut (6) securing support lever to left head and remove hot air intake.

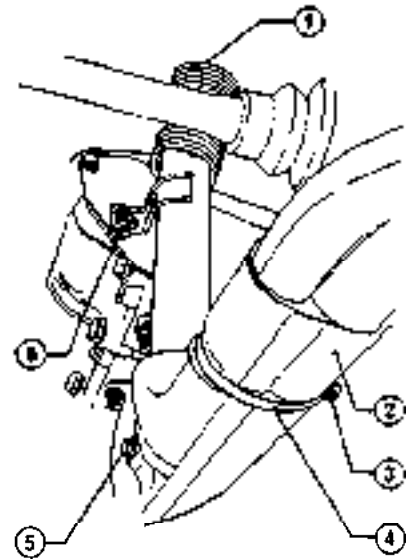

- | | |
|------------------|---------|
| 1 Sleeve | 4 Clamp |
| 2 Hot air intake | 5 Bolt |
| 3 Screw | 6 Nut |

INSTALLATION

Fit single parts back together following removal operations in reverse sequence and paying close attention to below instructions:

- Always fit new gaskets between manifold flanges and cylinder heads.
- Having completed installation, check and make sure that support rings move freely and are free of undue stress; check brackets making sure they have been properly secured.
- While engine is running check all pipe connections for gas leaks and the whole exhaust system for unusual noises.

SERVICE DATA AND SPECIFICATIONS

TECHNICAL DATA

FUEL PUMP

Type	ALFA ROMEO part No.	Brand	Model		
			1200 305.00	1350 305.02	1500 305.04
Mechanical	510.355	FISPA	4041.01	4059.01	
	531.354	SAVARA	960.084.00		
	542.140	SAVARA	906.130.00		

FUEL TANK

Overall capacity	l	50
	Imp. Gall	11
Reserve	l	6.5
	Imp. Gall	1.43

GENERAL SPECIFICATIONS

FLUIDS AND LUBRICANTS

Application	Type	Denomination	Qty
Spacer on accelerator pedal rotation pin	GREASE	AGIPF1 Grease 15 Standard 3671-69810	

CARBURETORS

ENGINE (1)	Displacement cm ³		1200		1350		1500		
	Type		309 AB		307 DC		305 AC		
	ALFA ROMEO Fuel No.		547 181		656 218		642 166		
CARBURETOR (Except Switzerland, Sweden, Australia)	Model	Twin Solex (2) (8) C 32 EIES 05		Twin Solex (2) (13) C32 EIES 04		Twin Mikar (2) (3) 32 DIR 73 R/Z00		Twin Mikar (2) (3) C 32 EIES 03	
	Position	CENTRE		CENTRE		CENTRE		CENTRE	
Venturi	Ø mm	23	24	23	24	23	24	23	
Main jet	Ø mm	122	130	120	130	122	130	122.5	
Accessory Venturi	Ø mm	4.5 norm.		4.5 norm.		4.5 norm.		-	
Mixer air corrector jet	Ø mm	180	170	170	170	180	170	180	
Mixture tube	Ø mm	F68	F67	-	F67	F68	F67	-	
Enrichment jet (if present)	Ø mm	40	99	0	85	40	85	0	
Jetting jet	Ø mm	50	50	50	50	50	50	50	
Jetting air corrector jet	Ø mm	155	115	135	120	185	135	120	
Progression holes	Ø mm	0.1 120 n. 3 0 100	0.2 0 130 n. 1 0 130	0.2 0 130 n. 2 0 130	0.2 0 120 n. 3 0 100	0.1 0 120 n. 1 0 120	0.2 0 110 n. 2 0 120	0.2 0 110 n. 2 0 120	
Acceleration pump jet	Ø mm	50	55	55	55	50	50	50	
Needle valve	Ø mm	175	160	160	175	160	175	160	
Thick part of gasket under needle valve	mm	-	1	1	-	-	-	1	
Float weight	g	11	15	15	11	11	11	7.0	
Secondary air jet	Ø mm	3.5	-	-	3.5	3.5	3.5	-	
Secondary air corrector jet	Ø mm	40	-	-	90	90	90	-	
Adjuster hole	Ø mm	60	-	-	50	50	50	-	
Adjuster air hole	Ø mm	-	0.80	0.80	-	0.80	-	0.50	
Adjuster air hole	Ø mm	-	0.90	0.90	-	0.90	-	0.50	
Adjuster axial hole	Ø mm	-	0.60	0.60	-	0.60	-	0.60	
Pump discharge	Ø mm	40	-	-	40	40	40	-	
Pump discharge jet	Ø mm	-	35	35	-	35	-	0	

1) Dimensions in 10⁻² mm
 (1) Different engine types are identified by the different progressive number (letters and numbers).
 See group 00

12) Carburetor with auxiliary screw for idling adjustment for adjustment
 13) Carburetor with throttle adjustment screw and stalling mixture

FUEL SYSTEM

RB R R

ENGINE	REPLACEMENT		1300	9580
	Type	301.56		
CARBURETOR (Switzerland, Sweden, Australia)	Alfa Romeo		306.221	305.14
	Part No			305.14
	Model			306.221
	Position			Twin Weber 32 DIR 91/150 CENTRE
		1st barrel	2nd barrel	
Venturi	mm	23	24	23
Auxiliary Venturi	mm	3.5 edge	4.5 norm	3.5 edge
Main jet	mm	122	130	122
Primary air orator jet	mm	190	170	180
Mixing tube		100	F 67	F 68
Enrichment jet	mm	40	9b	40
Jetting jet	mm	50		50
Idle air corrector jet	mm	138	116	185
Progressive holes	mm	1 hole \varnothing 120 3 holes \varnothing 100	3 holes \varnothing 120	1 hole \varnothing 120 3 holes \varnothing 100
Acceleration pump jet	mm	60	-	60
Pump discharge	mm	40	-	40
Needle valve	mm	175		75
Adjuster air hole	mm	35		35
Adjuster mixture hole	mm	90		90
Adjuster air jet hole	mm	50		50

Dimensions in 10^{-2} mm

FUEL SYSTEM

INSPECTION AND ADJUSTMENT

FUEL PUMP

	Fuel pump pressure	Pump delivery
FISPA	17.7 ÷ 29.4 KPa (0.177 ÷ 0.294 bar) (0.18 ÷ 0.30 kg/cm ²) (2.56 ÷ 4.27 psi) at 5000 rpm	—
SAVARA	17.7 ÷ 29.4 KPa (0.177 GO.294 bar) (0.18 ÷ 0.30 kg/cm ²) (2.56 ÷ 4.27 psi) at 6000 rpm	—

WARM - COLD AIR AUTOMATIC MIXER

Warm air inlet complete closing engine temperature thermostat temperature	warm > 33 ÷ 37 °C (▷ 91.4 ÷ 98.6 °F)
Cold air inlet complete closing engine temperature thermostat temperature	cold < 28 ÷ 32 °C (< 82.4 ÷ 89.6 °F)

ACCELARATOR CONTROL

Clearance between adjustment fork slot and throttle control shaft pin

G₁ mm (in) 1 (0.039)

Clearance between throttle control lever and relevant complete opening stop

G₂ mm (in) 1 ÷ 2 (0.039 ÷ 0.079)

CARBURETORS

ENGINE	1200		1250		1500	
	Displacement	306.00	305.02	305.02	306.00	306.00
CARBURETOR (Except Switzerland, Sweden Australia)	Type	534.537	538.215	542.059	535.695	536.755
	Part No	Webber 32 D1R 51 A/250	Webber 32 D1R 51 A/250	Webber 32 E1B5 44	Webber 32 D1R 71 A/250	Webber 3040x C 32 E1E5 43
	Model	Webber 32 D1R 51 A/250	Webber 32 D1R 51 A/250	Solex C 32 E1B5 44	Webber 32 D1R 71 A/250	Webber 3040x C 32 E1E5 43
	Position	CENTRE	CENTRE	CENTRE	CENTRE	CENTRE
	1st barrel	2nd barrel	1st barrel	2nd barrel	1st barrel	2nd barrel
Throttle opening with choke in use	mm	0.9±1	-	0.9±1	0.9±1	-
Choke opening by economizer	mm	5.5±0.5	-	4.5±0.75	-	4.5±0.75
Pump delivery for 20 strokes	cm ³	17±20	tot 16±20 8÷10	tot 17±21 8÷10	17±20	tot 18±22 8÷10
Float chamber height: g-cover (with gasket to float O ₂ dimensions)	mm	6.75±7.25	-	6.75±7.25	-	6.75±7.25
D-Float chamber hydraulic level (without cover)	mm	-	21±23	-	21±23	21±23

CARBURETORS

ENGINE	1860	1800
	301.66	309.14
	806.221	806.221
	T with valves 32 DIMS 91/150	
	CENTRE	
	1st barrel	2nd barrel
Throtty with choke in use	0.841	0.841
Choke-transmissives	5.548.5	5.548.5
Pump for 20 Fivobek	17-20	17-20
Fluct ranging: a. converval to first Q_{10} dimension	6.78-7.35	6.78-7.29

Displacement

Type

After-Runoff Part No

Model

Position

mm

mm

cm³

mm

FUEL SYSTEM

TIGHTENING TORQUES

Item	Unit	N·m	kg·m	ft·lb
Carburetors retaining nuts		19 ÷ 23.5	1.9 ÷ 2.4	13.74 ÷ 17.35

TROUBLE DIAGNOSIS AND CORRECTIONS

Condition	Probable cause	Corrective action
Fuel leakage	<ul style="list-style-type: none"> • Needle valve is dirty or its seat is loose on thread • Float sticks (hard on pin or sides) or is heavy • Pipes improperly tightened or broken • Gaskets are hard, worn or improperly tightened • Acceleration pump diaphragm is punctured or torn 	<p>Thoroughly clean petrol filter and needle valve; tighten seat firmly: if necessary, replace it with a new one (original parts)</p> <p>Free the float and adjust its movement: if necessary replace it (original parts)</p> <p>Tighten pipes and unions or replace defective ones</p> <p>Replace gaskets and tighten them properly</p> <p>Replace diaphragm</p>
Petrol does not reach carburetor	<ul style="list-style-type: none"> • Fuel pump or pipes are overheated and bubbles are present • Fuel pump is mechanically defective • Pipes, fuel filter or carburetor ducts are clogged by foreign matter • Fuel tank breather hose is clogged or there is a water deposit on tank bottom 	<p>Let bubbles out and try to eliminate overheating causes</p> <p>Overhaul pump replacing defective components or replace the whole pump</p> <p>Thoroughly clean pipes, filter and carburetor</p> <p>Unclog breather hose and eliminate water also from pipes and from carburetor float chamber</p>
Cold starting is difficult or impossible	<ul style="list-style-type: none"> • Having verified that fuel level in float chamber is absolutely correct, proceed to check following possible carburetor troubles. • Starting control cable does not slide freely, is broken, unhooked, etc. • Choke sticks so that it tends to stay either fully open or fully closed • Starting jet, if any, is dirty or has been tampered with 	<p>Restore proper fuel level in float chamber</p> <p>Repair or replace cable</p> <p>Free choke movement</p> <p>Clean or replace jet</p>

FUEL SYSTEM



Condition	Probable cause	Corrective action
Cold starting is difficult or impossible (continue)	Starting control valve, if any, is sticky Ignition and starting systems are out of order	Free valve movement so that it can properly follow control cable Overhaul ignition and starting systems
Excessive fuel consumption	Carburation, ignition or compression are defective, as also mentioned in case of insufficient max speed Air cleaner intake stopped in the warm position Twin carburetor goes into action too early	Checking operations to be performed same as previously mentioned Replace thermostat located into cleaner air intake CAUTION: Special attention should be paid when checking fuel consumption since speed load, road type as well as driving habits play an important part in establishing actual running fuel consumption Adjust relevant controls
Slow pickup especially when in direct drive	Carburation, ignition or compression are defective, as also mentioned in case of insufficient max speed (presence of exhaust smoke is possible) Acceleration pump not properly adjusted or defective or pump circuit of jet and valves is defective Diffuser well is clogged or otherwise defective	Checking operations to be performed same as previously mentioned Overhaul pump and relevant circuits Carefully overhaul air jet, diffuser and relevant well making sure that all components are properly rated
Engine easily knocks, overheats or self-ignites	Carburation or ignition are defective, as also mentioned in case of insufficient max speed Octane rating of petrol used is too low Engine cooling system is defective Excessive scaling of engine cylinders Having also excluded any ignition defect, engine compression will have to be tested since there could be leaks coming from piston rings, valves or cylinder head gaskets Engine compression is poor	Checking operations to be performed same as previously mentioned Replace petrol in tank with a kind having a higher octane rating Check radiator, relevant thermostat or shutter, if any, since the latter could be improperly adjusted Proceed to scale the engine Check engine compression by means of suitable gauge screwed onto spark plug holes; overhaul or replace any defective engine parts Check compression and, if necessary, overhaul the engine

FUEL SYSTEM

Condition	Probable cause	Corrective action
<p>Improper engine idling or progression phases</p>	<ul style="list-style-type: none"> • Inadequate fuel level in float chamber or defective starter, ignition or overall engine operation as previously mentioned in connection with difficult cold starting • Adjustment of idling adjusting screws is incorrect ▸ Idling jet is dirty, loose or has been tampered with ▸ Progression holes or channels of idling circuit are clogged or have been tampered with ▸ Air leaks from fitting flanges or other connections ▸ Throttle valve shaft has air leaks from intakes ▸ Throttle valve or relevant controlling parts are sticky ▸ Twin carburetor's second throttle valve does not work properly 	<p>Perform same checks and repairs as previously described</p> <p>Carefully repeat all relevant adjustments as per maintenance instructions</p> <p>Check or replace idling jet</p> <p>Check and thoroughly clean holes and channels</p> <p>Tighten as required and, if necessary, replace relevant worn gaskets</p> <p>Replace shaft and, if necessary, fit an oversize shaft after having suitably reamed relevant holes in the body</p> <p>Free throttle valve</p> <p>Overhaul and clean</p>
<p>Power shortage (insufficient max speed)</p>	<ul style="list-style-type: none"> ▸ Inadequate fuel level in float chamber or defective starting, ignition or compression as previously mentioned ▸ Main jet, power jet, air adjusting screw or diffuser are clogged, loose or have been tampered with ▸ Fuel filter in tank or in carburetor is clogged ▸ Air cleaner clogged ▸ Throttle valve does not fully open 	<p>Perform same checks and repairs as previously described</p> <p>Check, thoroughly clean or replace defective parts</p> <p>Clean the filter</p> <p>Clean air cleaner and replace cartridge</p> <p>Check throttle valve and relevant controlling parts</p>
<p>Exhaust system is unusually or excessively noisy</p>	<ul style="list-style-type: none"> • Holes in manifolds • Holes in pipes • Gas leaks from loose connections 	<p>Replace damaged parts</p> <p>Replace damaged parts</p> <p>Tighten properly as required</p>

FUEL SYSTEM

SPECIAL SERVICE. TOOLS

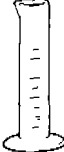
Tool number	Tool name	<i>Refer to page</i>
C.4.0101	Carburetor pump test 	04-6
C.4.0103	Twin carburetor support (to be used with C.4.0101) 	04-6
C.4.0105	Beaker for carburetor pump tests (to be used with C.4.0101) 	04-6

IGNITION, STARTING, CHARGING SYSTEM

GROUP 05

CONTENTS

BATTERY	05-2	Test stand inspection	05-24
STARTER	05-4	Service data and specifications	05-24
Wiring diagram	05-4	Trouble diagnosis and corrections ...	05-25
Disassembly	05-7	TRANSISTORIZED IGNITION	
Checks and inspections	05-10	WITHOUT CONTACTS	05-26
Reassembly	05-12	Wiring diagram	05-26
Test stand inspection	05-12	Description	05-27
Service data and specifications	05-12	Checks and adjustments	05-28
Trouble diagnosis and corrections ...	05-13	Disassembly	05-31
CHARGING	05-15	Checks and inspections	05-32
Wiring diagram	05-15	Reassembly	05-33
Disassembly	05-18	Test stand inspections	05-33
Checks and inspections	05-21	Service data and inspections	05-33
Reassembly	05-24	Trouble diagnosis and corrections ...	05-36

BATTERY

WARNING:

- a. Do not touch both the positive and negative terminals of the battery at the same time with your bare hands.
- b. In case of necessity use a 12-volt booster battery with jumper leads for starting the engine.

CHECKS

1. The container has no cracks in it.
2. Verify that electrolyte level covers electrodes of about 4 ÷ 5 mm (0.16 4 0.2 in).
3. The top of the battery is clean and the terminals are not oxidized or dirty.
4. The lead terminals are well fastened on to the battery terminals and make good contact.

CLEANING

1. Clean the top of the battery, its terminals and the lead terminals with a solution of sodium bicarbonate in water.
2. Before reassembling terminals, it is necessary to grease them with the prescribed grease: Grease REINACH E 10 Tac.

WARNING:

Do not let the cleaning fluid get into the battery: it will react with the electrolyte. The electrolyte is acid and therefore dangerous to eyes, hands and clothes.

SPECIFIC GRAVITY

1. Verify that electrolyte is at correct level.
2. By means of a bulb hydrometer, extract electrolyte from each cell and check the specific gravity.

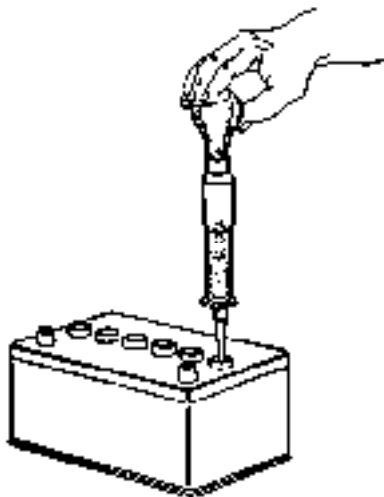

3. Take the temperature "t" of the electrolyte with a thermometer.
4. Calculate the specific gravity at 25°C (77°F) from the formula

$$sg_{25} = sg_t + 0.0007 (t - 25) \text{ (kg/dm}^3\text{)}$$

where:

sg_t = Specific gravity of electrolyte at t°C

t = Electrolyte temperature

Examples

1. Electrolyte s.g. at 15°C (59°F): 1.290 kg/dm³
s.g. at 25°C (77°F) will be:

$$sg_{25} = 1.290 + 0.0007 (15 - 25) = 1.283 \text{ kg/dm}^3 \text{ (35.51 lb/cu in)}$$

2. Electrolyte s.g. at 35°C (95°F): 1.275 kg/dm³
s.g. at 25°C (77°F) will be:

$$sg_{25} = 1.275 + 0.0007 (35 - 25) = 1.282 \text{ kg/dm}^3 \text{ (35.48 lb/cu in)}$$

5. Compare then the density calculated at 25°C (77°F) with the value prescribed for an efficient battery.

An efficient battery electrolyte specific gravity is

$$d = 1.28 \pm 0.01 \text{ kg/dm}^3$$

6. If necessary charge the battery.

Batteries left on the shelf or in cars unused for long periods gradually lose their charge. Therefore they need to be charged up again when they are to be used.

CHARGING

WARNING:

- a. Remove the negative connection before starting to charge the battery.
- b. Do not let the electrolyte heat up above 45°C (113°F) during charging.

CAUTION:

- a. Do not use naked flames near the battery while charging.
- b. First connect the battery to the charger and then switch on the charger.

CELLS TEST

This test should be performed with the correct electrolyte s.g. Measure the discharge voltage at the terminals of each cell.

1. Remove the plugs from the filler holes.
2. Put the test probes in two adjacent holes (positive and negative) as shown. The needle should flip over to the green zone (charged).
3. Repeat for the other two pairs of holes.



4. If the needle stops in the red zone (low charge) at the same point for each cell, charge the battery.

IGNITION, STARTING, CHARGING SYSTEM

5. If the needle stops in the red zone (low charge) but at quite different points for the different cells, put in another battery.

USING THE ELECTRONIC BATTERY TESTER (MOTOROLA)

Connect the positive instrument clip to battery positive (+) and negative to negative (-). Set battery voltage switch ③ to 12V, temperature compensator ② to the estimated battery temperature, and current calibrator ④ to the battery amps according to type.

Voltage test

1. Switch selector ① to VOLT.
2. The reading on the VOLT scale must be greater than 12.4 V.

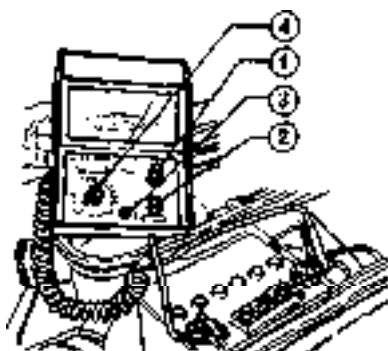

- 1 Selector switch
- 2 Temperature compensation
- 3 Battery voltage switch
- 4 Current calibration

3. If battery voltage shows less than 12.4V, charge the battery and repeat the test. If the voltage again shows less than 12.4V, a cell may be shortcircuited. Change the battery for another one.

Battery state

1. Set the instrument selector switch to "Cond. Batt."
2. The needle should flip over to the GREEN zone on the RED-GREEN scale.
3. If it does not, put in another battery.

Power test

1. Set instrument selector switch to "kW".
2. The needle should read between 2 and 4 kW on the kW scale.
3. If it does not, put in another battery.

Charge test

1. Set instrument selector switch to VOLT.
2. Start the engine and let it idle until the needle settles to its reading.
3. The reading should be between 13.6 and 15V.
4. If the reading is outside (above or below) these limits, check the alternator for defects, especially the voltage regulator (see Charging - Checks and Inspections).

Also check alternator belt tension (see: Group 00 Engine Maintenance).

Starting test

1. Set instrument selector switch to VOLT.
2. Take the ignition HT lead off the coil.
3. Start the engine and check the needle does not drop below 9 V on the Volt scale.
4. If it does, examine the starting system (see: Starting).

SERVICE DATA AND SPECIFICATIONS

Technical Data

	Car	1200 1350 - 1500		1500 Quadrifoglio
Battery				
Voltage	V	12		
Capacity	Ah	43		55
		45		60
Discharge current	A	181		255
		185		275
Electrolyte s.g.	kg/dm ³ (lb/in ³)	1.28 ± 0.01 (35.43 ± 0.27)		

IGNITION, STARTING, CHARGING SYSTEM

General Specifications

FLUID AND LUBRICANTS

Application	Type	Denomination	Q.ty
Battery terminals	GREASE	Grease REINACH: E 10 Tac Std. no. 3671 - 69812	—

STARTER

WIRING DIAGRAM

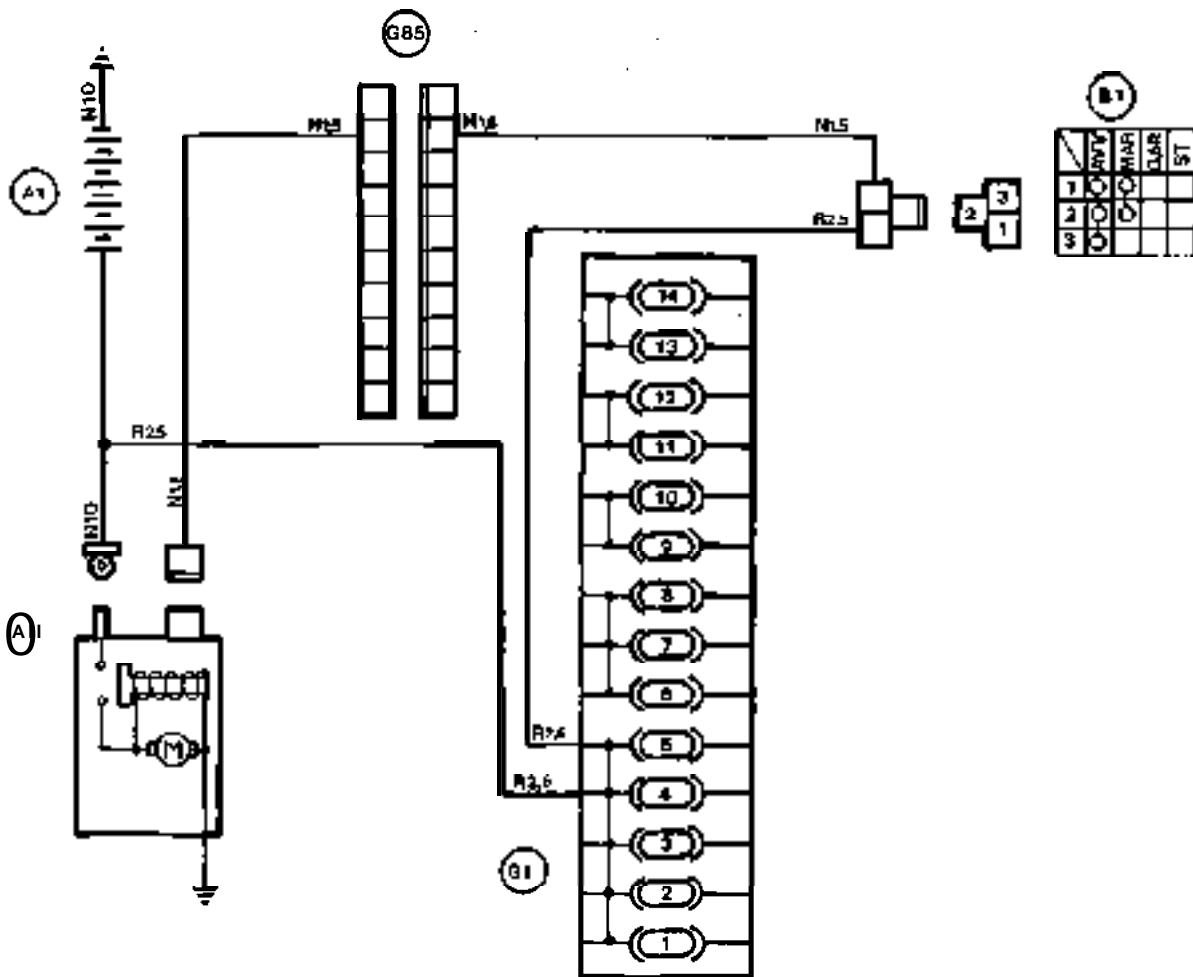

- A1. Battery
- A1.1. Starter
- G1. Fuseholder box
- G85. Front service junction
- E1. Ignition switch

IGNITION, STARTING, CHARGING SYSTEM

BOSCH STARTER MOTOR

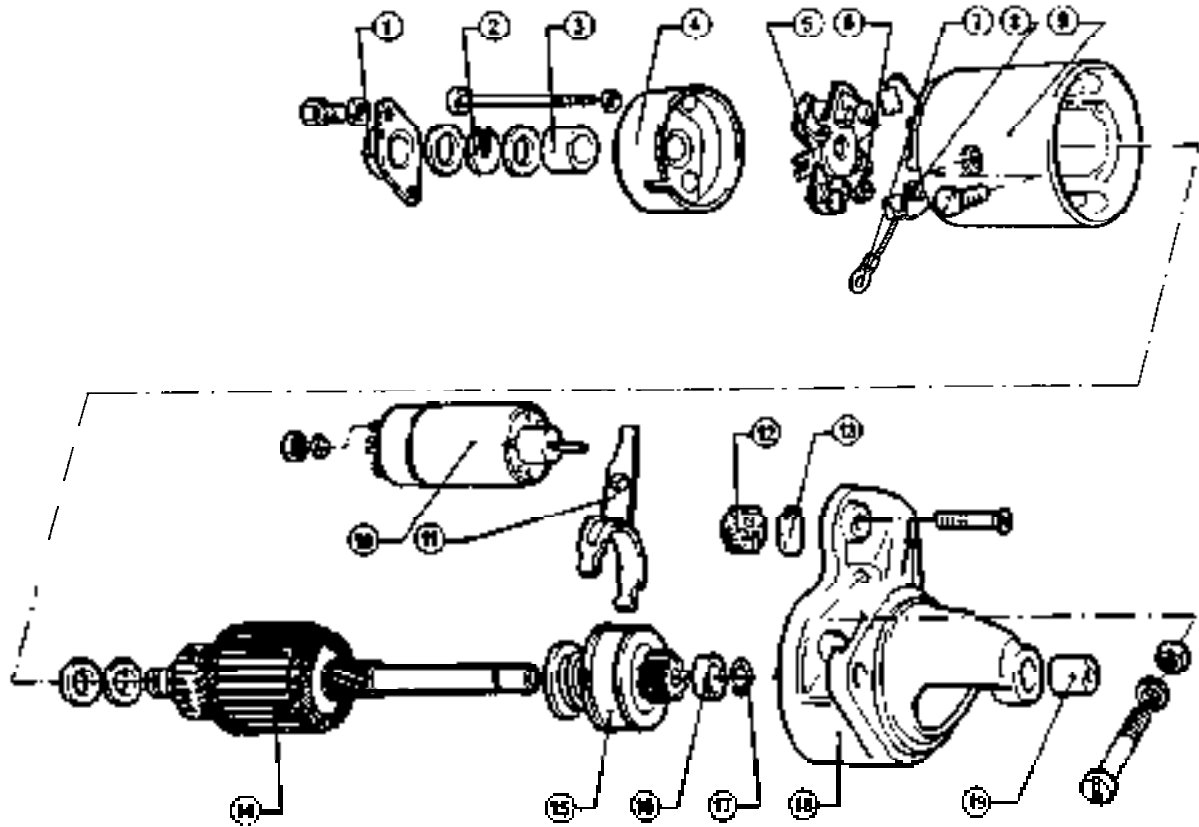

- | | | | |
|----|------------------------|----|------------------|
| 1 | Dust cover | 11 | Fork |
| 2 | Retaining ring | 12 | Rubber block |
| 3 | Bush | 13 | Lamination |
| 4 | Commutator casing | 14 | Rotor |
| 5 | Brush holder | 15 | Starting clutch |
| 6 | Brush spring | 16 | Snap ring |
| 7 | Excitation winding lug | 17 | Pinion stop ring |
| 8 | Brush | 18 | Drive housing |
| 9 | Yoke | 19 | Bush |
| 10 | Electromagnet | | |

DUCELLIER STARTER MOTOR

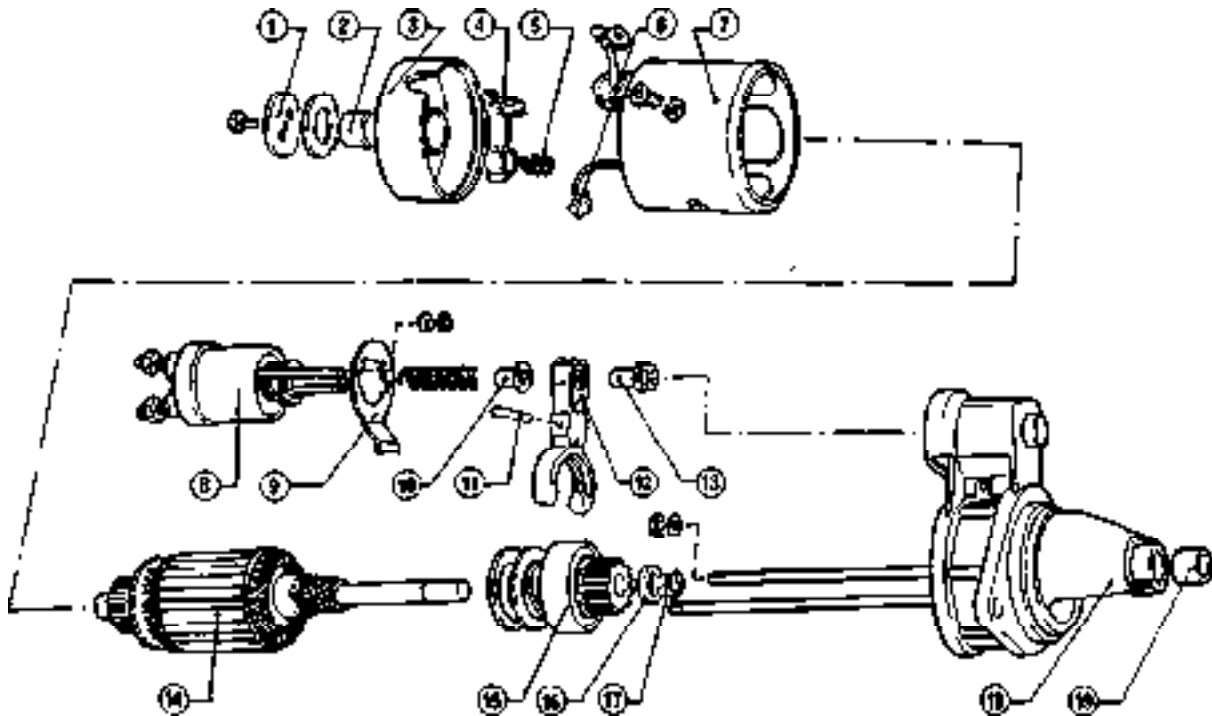

- | | |
|---------------------|---------------------|
| 1 Washer | 11 Trunnion |
| 2 Bush | 12 Fork |
| 3 Commutator casing | 13 Screw |
| 4 Brush holder | 14 Rotor |
| 5 Brush spring | 15 Starting clutch |
| 6 Brush | 16 Snap ring |
| 7 Yoke | 17 Pinion stop ring |
| 8 Electromagnet | 18 Drive housing |
| 9 Plate | 19 Bush |
| 10 Locator | |

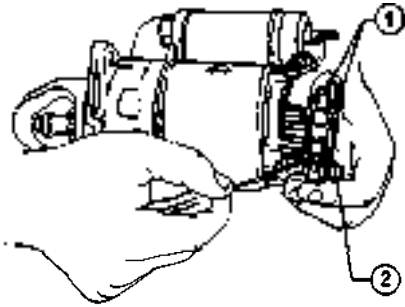

1- Brush spring 2 Brush holder

6. Extract the two positive brushes ① from the brush holder ② and take off the brush holder with the two negative brushes ③.

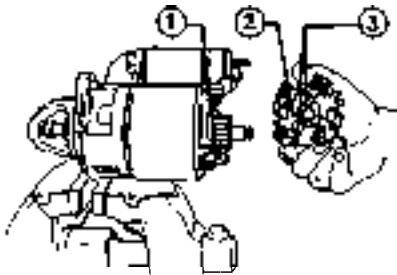

1 Positive brushes 3 Negative brushes
2 Brush holder

7. Unscrew the excitation winding lug ② securing nut ③ from the electromagnet terminal ① and withdraw the yoke ④ complete with excitation winding.

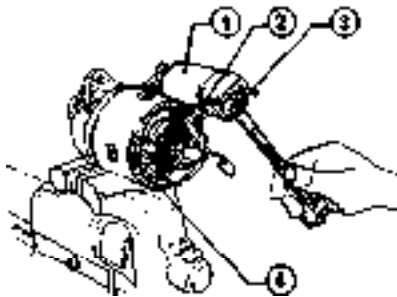

1 Electromagnet 3 Nut
2 Excitation winding lug 4 Yoke

8. Unscrew the two screws ① securing the electromagnet ② to the drive housing ③ and take out the electromagnet.

9. Remove the rubber block ④ with the lamination.

10. Unscrew the bolt ⑤ serving as clutch fork pivot.

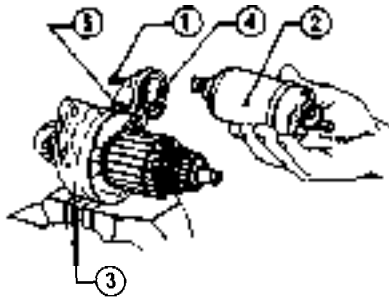

1 Electromagnet screw 3 Drive housing
2 Electromagnet 4 Rubber block 5 Bolt

11. Withdraw the rotor ② together with the starting clutch ③ and the forked lever ①.

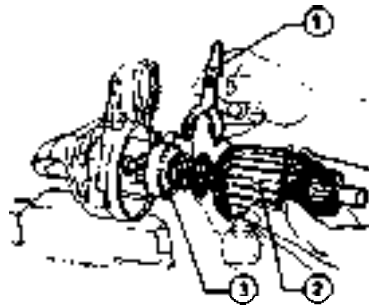

1 Fork 3 Clutch
2 Rotor

Hold the rotor in a vice with caps.
12. Free the pinion stop ring ① from the snap ring ② with a box spanner.

13. With a pair of pliers remove the snap ring ② from the rotor shaft and slip off the pinion stop ring.

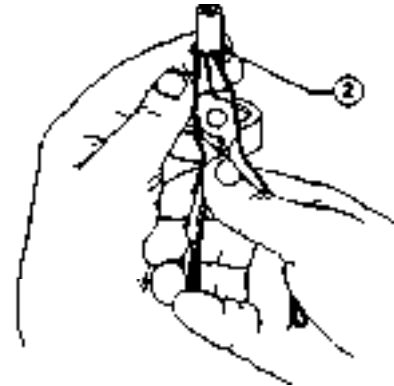
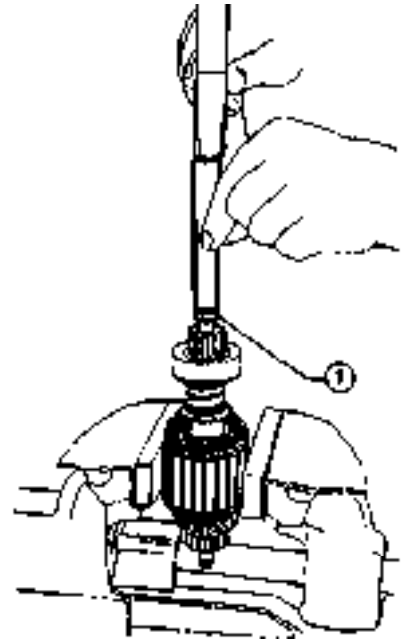

1 Pinion stop ring 2 Snap ring

14. Withdraw the starting clutch ①.

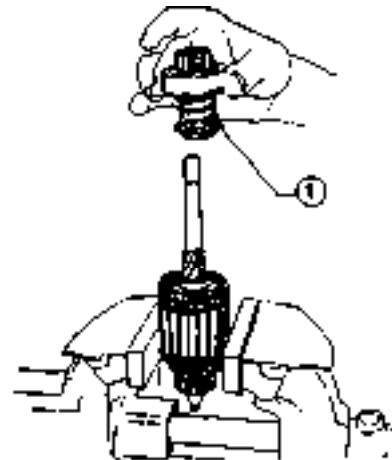

1 Starting clutch

15. Unscrew the inductor winding 1 securing screw on the yoke 2 and extract the winding.

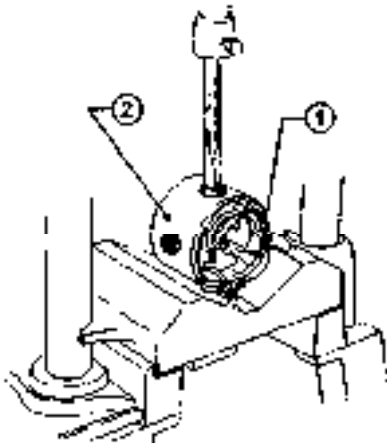

1 Inductor winding 2 Yoke

16. If necessary, extract the bushes from the commutator casing and the drive housing with the use of a punch.

DUCELLIER STARTER MOTOR

Hold the motor in a vice with caps.
1. Hold the pinion firm with pliers and unscrew the pinion adjusting screw (2). Take out the screw and the washers under it.

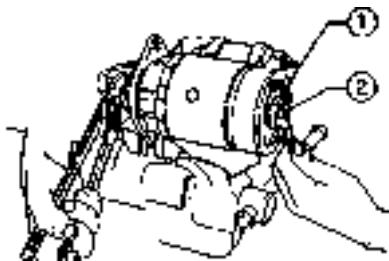

1 Washer 2 Screw clamping

2. Unscrew the two nuts clamping the commutator casing (2) and the stator yoke on the pinion housing on to the stud bolts. Remove the commutator casing with the brush holder (3).

3. Unscrew the excitation winding lug (1) fixing nut on the electromagnet. Remove the stator and the rotor (4).

4. Punch on the trunnion (6) for the fork on the pinion housing (5).

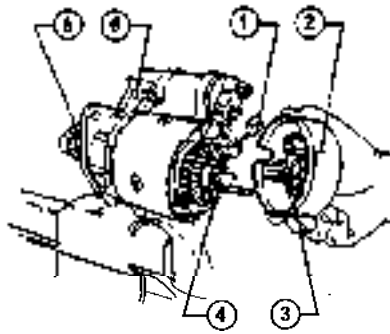

1 Lug 2 Commutator casing 3 Brush holder 4 Rotor 5 Pinion housing 6 Trunnion

5. Unscrew the nuts (2) and remove the electromagnet (1).

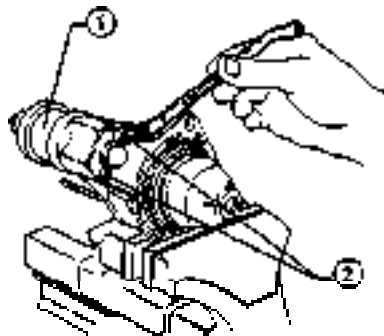

1 Electromagnet 2 Nuts

6. Hold the electromagnet in a vice with caps. Use a screwdriver to keep the electromagnet shaft from turning and unscrew the pinion clutch fork (2) clamping nut (1). Remove the fork, spring and striker.
7. If necessary take the inductor winding out of the yoke (see: Bosch Starter Motor, step 15.) and the bushes from out of the commutator casing and the drive housing.

CAUTION:

When unscrewing nut (1), count the exact number of threads to when it is free so that it may be screwed up the same amount in re-assembly and correct fork adjustment had.

8. Strip the rotor as for the Bosch (see: Bosch Starter Motor, steps 12 and 13).

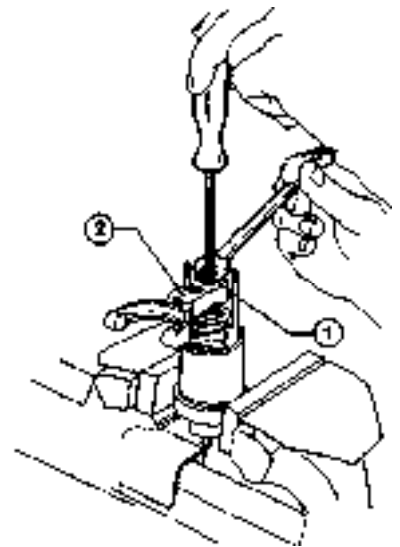

1 Nut 2 Fork

MARELLI STARTER MOTOR

Hold the starter motor in a capped vice.

1. Unscrew the two screws (3) securing the dust cover and take it off.

2. Unscrew the two nuts (2) with washers securing the commutator casing (1) and remove it.

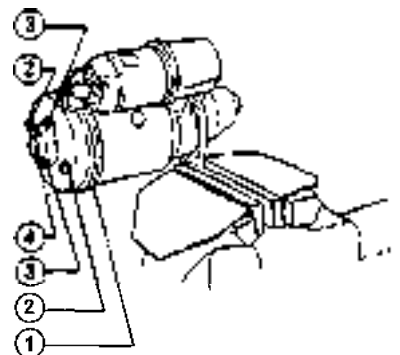

1 Commutator casing 2 Nut 3 Screws 4 Dust cover

3. Unscrew the electromagnet excitation winding lug nut and take the yoke out of the starter motor containing the stator windings.

4. Extract the pivot cotter pin and take the starter engaging fork pivot.

5. Remove the rotor electromagnet assemblage and take the rotor to pieces as for the Bosch starter motor (see: Bosch Starter Motor, steps 12., 13. and 14.).

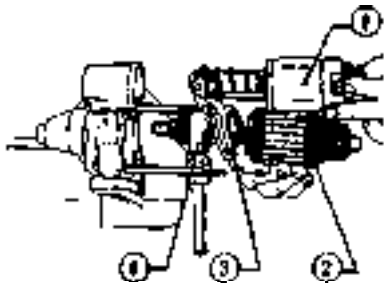

1 Electromagnet 3 Fork
2 Rotor 4 Clutch

6. If necessary, take the field winding out of the yoke (see: Bosch starter motor, step 15) and the bushes out of the commutator casing and out of the drive housing.

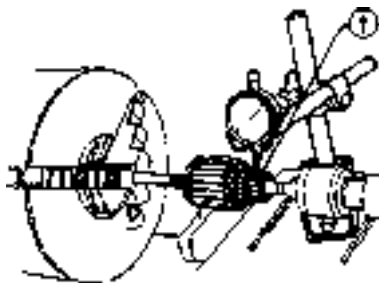

1 Commutator

4. If greater errors than these are found or if the commutator is badly scored, put in a new rotor unless it would seem enough to turn the rotor and smooth it with a piece of cloth for rotors.

Bosch and Marelli Starter Motors

Max turning depth on nominal thickness
0.25 mm (0.0098 in)

Commutator continuity test

1. Set the tester to the $\Omega \times 100$ scale.
2. Put the prods on the commutator segments of the pack under test:
3. The test should show current flow.

Rotor insulation test

1. Set the tester to $\Omega \times 1$ scale.
2. Put one prod on the commutator and the other on the segment pack or shaft.
3. There should be no sign of current flow by the tester.

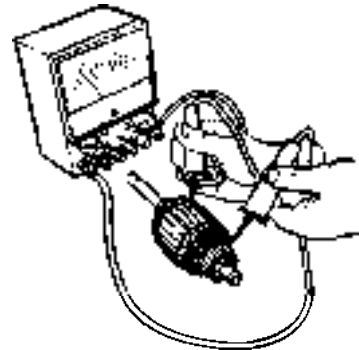

4. If the insulation is broken (short circuit) put in another rotor.

CAUTION:

Repeat steps 2. and 3. for all the commutator segments.

Rotor shortcircuit test on test stand

1. Position the rotor between the pole pieces of the rotor testing apparatus and switch on.
2. Slowly rotate the rotor and rest the steel blade on the rotor pack.



3. The blade will stick to the pack in correspondence with the faulty lead cables if there is a short circuit.

Excitation winding insulation test

1. Set the tester to the $\Omega \times 1$ scale.
2. Put one prod on the lug of the induction windings and the other prod on the yoke.

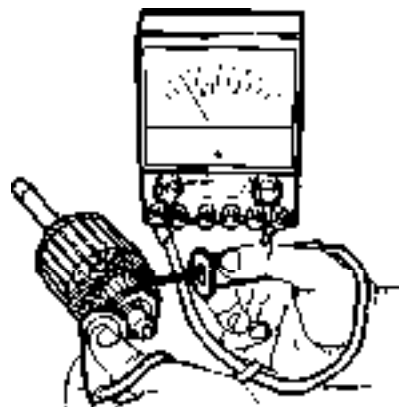

If there is no electrical continuity, put in a new rotor.

CAUTION:

Repeat steps 2. and 3. for all the pairs of commutator segments.

CHECKS AND INSPECTIONS

Before making any electrical inspection thoroughly blow-clean the components and especially the ends of the winding with compressed air and clean the commutator with a cloth slightly wetted with petrol.

Commutator wear

1. Put the rotor on a lathe.
2. Place a magnetic-based centesimal dial gauge on the lathe carriage with the gauge feeler in contact with the commutator ①.
3. Bosch and Marelli Starter Motors Eccentricity should not be more than the stated maximum.

Max permissible commutator eccentricity
b.06 mm (0.0024 in)

3. The tester should give no sign of current flow.

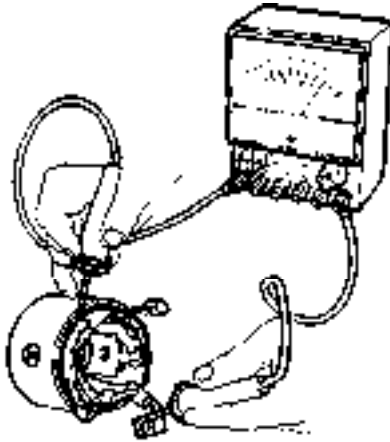

4. If insulation is broken, remove the excitation winding from the yoke and put another winding in its place (see: Bosch Starter Motor, step 15).

Excitation winding continuity test

- f. Set the tester to the $\Omega \times 100$ scale.
2. Put one prod on the induction winding cable and the other prod on the positive brush. (Repeat with the other brush).
3. The tester should show current flow.

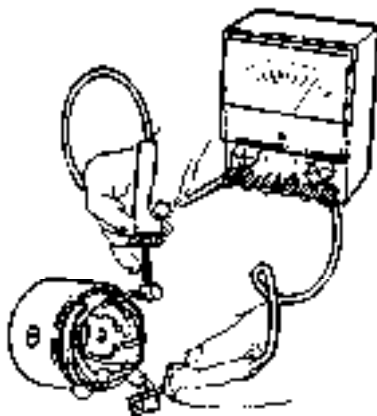

4. If continuity is broken in the windings, remove the windings from the yoke and put in others in their place (see: Disassembly Bosch Starter Motor, step 15).

Positive brush holder insulation test

1. Set the tester to the $\Omega \times 1$ scale.

2. Put one prod on the brush holder plate and the other prod on a positive brush holder.

3. The tester should give no sign of current flow.

4. Repeat the test on the other positive brush holder.

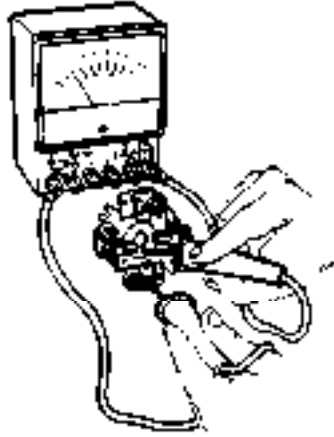

5. If insulation is broken, put in another brush holder plate.

Electromagnetic efficiency check

1. Shortcircuit the electromagnet with the starter pin ② and connect its positive pole ③ to the positive terminal of a battery.
2. Connect the battery's negative terminal to the electromagnet's yoke ①.

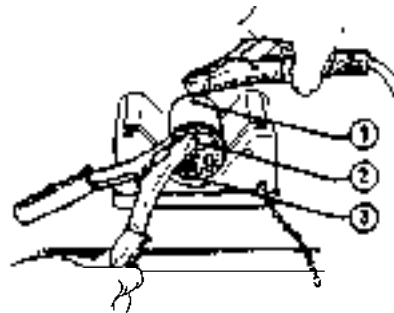

1 Yoke 3 Electromagnet positive pole
2 Pin

3. The starter drive fork actuator should trip. If it does not, put in another electromagnet.

Pinion efficiency check

1. Rotate the pinion clockwise as shown in the figure. It should rotate freely.
2. Rotate the pinion counter-clockwise, i.e. in the direction of meshing. It should lock.

3. Eye check the pinion teeth.

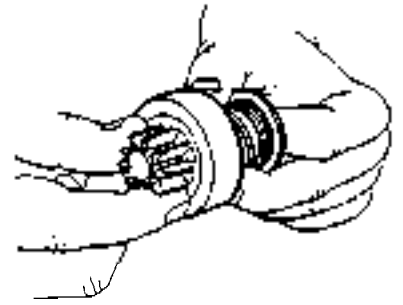

4. If the pinion does not work properly or the teeth show excessive signs of wear replace the starter clutch.

Brush spring check

1. Check that the brush springs have not lost their elasticity and still ensure good brush contact on the commutator.
2. If necessary, put in new springs.

Brush wear inspection

Check that the stator and rotor brushes are not chipped or dirty with carbon deposits and check that their lengths are within the prescribed limits.

Brush lengths (min)

Bosch 11 mm (0.433 in)
Ducellier 9 mm (0.354 in)
Marelli - mm (— in)

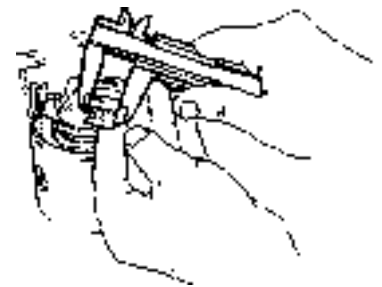

Bush wear inspection

1. Check that the two bushes on the front and rear rotor shaft bearings are not excessively or unevenly worn. Side play between shaft and bush should lie within the limits.

Shaft-bush clearance
(0 bush 0 shaft) =
0.02 ÷ 0.05 mm
(0.00079 ÷ 0.00197 in)

2. If wear is excessive, put in new bushes (see: Disassembly Bosch

Starter Motor, step 16).

CAUTION:

Make sure the bushes are assembled properly and the rotor shaft turns easily and without play.

REASSEMBLY

Follow the disassembly steps in the opposite order and lubricate the following parts with the prescribed grease.

Surfaces in motion relative to the starter motor

- Commutator casing bush
- Drive housing bush
- Pinion gear
- Starting system sliding spiral coupling
- Electromagnet push rod

TEST STAND INSPECTION

Put the starter motor on the test

stand to correspond with the crown wheel and connect up to the electrical system.

CAUTION:

The battery used in the test should have a high enough capacity to avoid voltage variations.

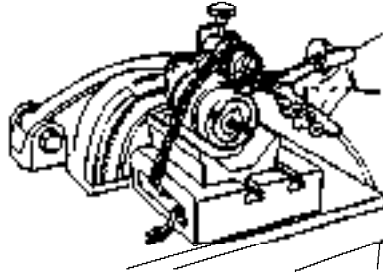

1. Under-load test

- (1) Apply the rated voltage to the starter motor. Switch on the starter so that the pinion turns the crown wheel and check for good working.
- (2) Brake the crown wheel and

adjust the absorber current to the value in the under-load test.

The torque should be that shown in the technical particulars.

2. Across-line test

- (1) Apply the rated voltage to the starter motor.
- (2) Lock the crown wheel brake.
- (3) Start up the starter motor and take a quick reading. Current, voltage and torque should be those given in the technical particulars.

3. Test with e.m. switch on the starter motor

- (1) Remove the starter motor away from the crown wheel so that the pinion will not engage it.
- (2) Apply the rated voltage to the starter motor. Switch on the starter motor. The absorbed current should be that given in the technical data.
- (3) PICK-UP/CUT-IN voltage should be that given in the technical data.

SERVICE DATA AND SPECIFICATIONS

TECHNICAL DATA AND INSPECTION

Starter Motor

			Mfg Romeo Class		
Type			533.051	533.052	536.611
Name			BOGOM EF 12V 0.9 kW 0001211 205	DUCELLER 6346/0	MARELLI E95 0.9 kW 12 v
Voltage	V		12	12	12
Min brush length	mm (in)		11 (0.433)	8 (0.315)	-
Max commutator eccentricity	mm (in)		0.08 (0.0031)	-	0.08 (0.0031)
Shaft-bush side play	mm (in)		0.02 ÷ 0.05 (0.0008 ÷ 0.002)		
Under-load test (pinion meshed with crown wheel with torque dynamometer)					
- Voltage	V		10	10	9.8
- Absorbed current	A		≤ 230	≤ 200	215
- Speed	rpm		≥ 1,450	≥ 1,450	1,800
- Torque	N·m (kg·m) (ft·lb)		5 (0.5) (3.62)	5 (0.5) (3.62)	5 (0.5) (3.62)
Across-line test (pinion meshed with locked crown wheel)					
- Voltage	V		8	8	8
- Absorbed current	A		≤ 400	≤ 380	400
- Torque	N·m (kg·m) (ft·lb)		≥ 10.5 (1) (7.231)	≥ 11 (1.1) (7.95)	12 (1.2) (8.68)

IGNITION, STARTING, CHARGING SYSTEM

Starter Motor

		533.051	533.052	536.611
<i>Alfa Romeo Class</i>				
<i>Type</i>				
<i>Item</i>				
		BOSCH EF 12V 0.8 kW 0001211215	DUCELLIER 6246/C	MARELLI E95 - 0.9 kW 12 v
Over running torque	N·cm (kg·cm) (in·lb)	13 ÷ 22 (1.3 ÷ 2.2) (1.13 ÷ 1.91)	11317 (1.1 ÷ 1.7) (0.95 ÷ 1.48)	15 ± 3 (1.5 ± 0.3) (1.30 ± 0.261)
EM Switch on starter motor				
-- Max absorption current at rated voltage	A	≤ 40	≤ 40	55
-- Min pickup voltage	v	8	≤ 8	7
Pinionmodule		2.116	2.116	2.116

TROUBLE DIAGNOSIS AND CORRECTIONS

Condition	Probable cause	Corrective action
Starter motor does not turn and no current flows	<ul style="list-style-type: none"> ▸ Break in electric circuit between battery and starter motor ▸ Break in electric circuit between starter motor and starter switch ▸ Battery terminals dirty or loose connections ▸ Starter motor electromagnet or winding or is earthed ▸ Excessively worn brushes not making contact on the commutator 	<p>Locate and repair it Check battery terminals and starter cable terminals. Tighten up the securing screws</p> <p>Locate and repair it. Check switch contacts and replace if necessary</p> <p>Clean the terminals and tighten up the connections</p> <p>Clean the moving and fixed contacts of the switch when possible and replace it if necessary</p> <p>Replace the brushes with other original ones after checking state of commutator</p>
Current flows but starter motor does not turn, or turns slowly, or starting does not take place	<ul style="list-style-type: none"> ▸ Rotor is rubbing against the pole pieces or is being held between the poles ▸ Rotor shaft seized up ▸ Field winding short circuited or earthed • Broken or earthed rotor • Rotor short circuited 	<p>Replace the bearings if the bushes are too worn. Check bearing alignment. Examine rotor shaft. See that the poles are well located and securely clamped into the yoke</p> <p>Replace the rotor and the piece with the seized-up bush</p> <p>Take out the field coils and put in new ones</p> <p>Replace the rotor</p> <p>Clean the carbon and copper dust off-the commutator and brush holders and if necessary replace the rotor</p>
Starter motor turns but starting does not take place	<ul style="list-style-type: none"> ▸ Crown wheel teeth worn: pinion does not engage 	Replace starting ring gear

IGNITION, STARTING, CHARGING SYSTEM

Condition	Probable cause	Corrective action
<p>Starter motor turns but starting does not take place (continued)</p>	<ul style="list-style-type: none"> • Wrong assembly: pinion engages only partially • Impurities in the coupling: Clutch does not slide on rotor shaft • Pinion engages ring gear properly but the engine does not start 	<p>Check concentricity and pinion-ring gear distance</p> <p>Clean and lubricate. If necessary clean the coupling completely</p> <p>Pinion free wheel defective and must be replaced. Faulty clutch to overhaul or replace. Electro-magnet not working properly: repair or replace</p>
<p>Starter motor turns normally but makes excessive or unusual noise</p>	<ul style="list-style-type: none"> • Defective mechanical parts • Foreign bodies have got into it 	<p>Check bearings. Examine bushes and if necessary replace bearings</p> <p>Clean them out</p>
<p>Starter motor does not develop max power</p>	<ul style="list-style-type: none"> • Brush contact on commutator not good • Brushes do not slide freely in the guides 	<p>Replace brushes or snug them by running the motor on no-load for some time. Check brush spring loading and replace them if they have lost their elasticity</p> <p>Clean the brush-holder guides or replace the brush holders if necessary</p>
<p>Excessive brush wear</p>	<ul style="list-style-type: none"> • Ovalized commutator • Mica projecting out of commutator copper sections • Brushes press excessively on commutator • Wrong brushes 	<p>Turn within in prescribed limits, remove mica and clean commutator</p> <p>Remove mica and clean commutator</p> <p>Check brush spring loadings for prescribed values</p> <p>Replace with others of prescribed type</p>
<p>Sparking at the commutator</p>	<ul style="list-style-type: none"> • Electrical overload in general • Slack brush springs • Mica projecting from copper 	<p>Overhaul the engine</p> <p>Replace brush springs</p> <p>Remove mica and clean the commutator</p>

BOSCH ALTERNATOR

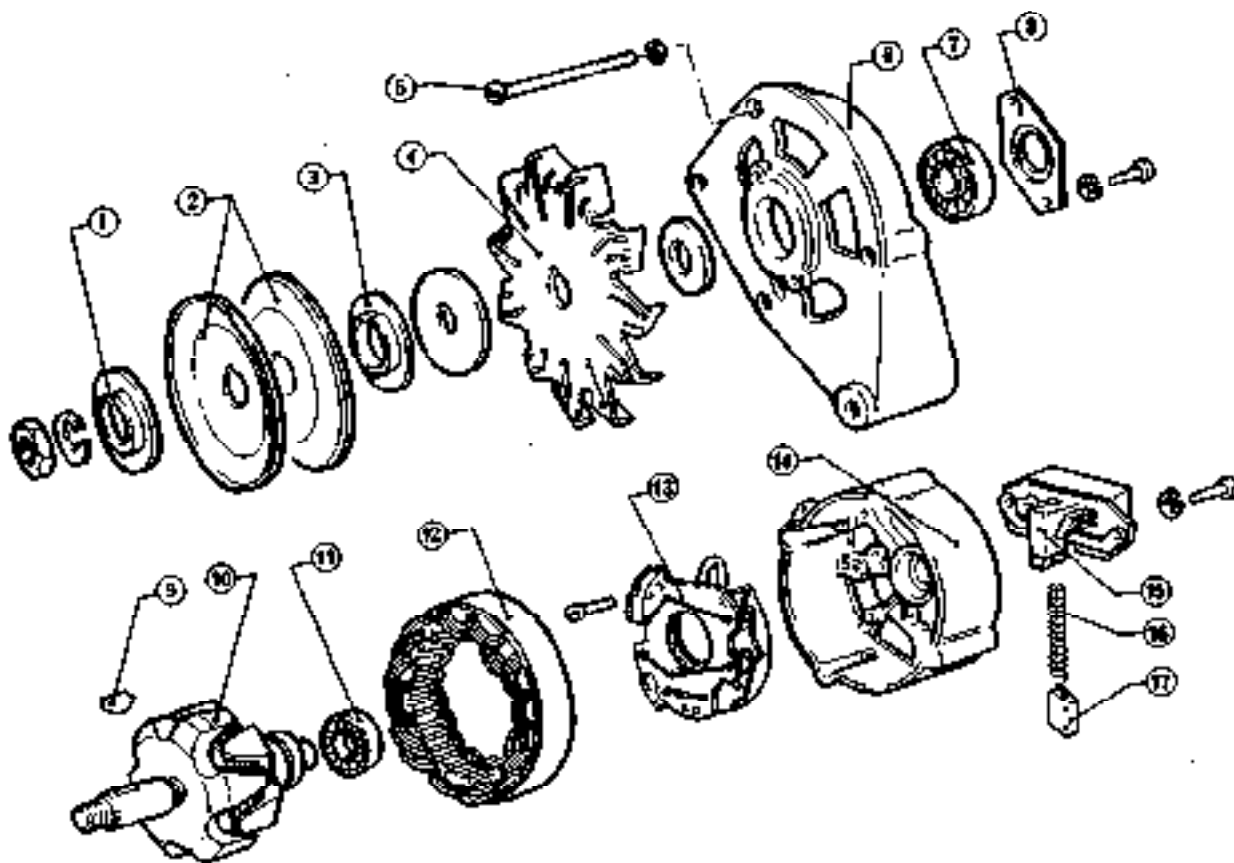

- | | | | |
|---|----------------------|----|--------------------------------|
| 1 | Distance piece | 10 | Rotor |
| 2 | Semipulleys | 11 | Regulator side bearing |
| 3 | Distance piece | 12 | Stator |
| 4 | Fan | 13 | Diode - holder plate |
| 5 | Stay bolt | 14 | Regulator mounting |
| 6 | Drive housing | 15 | Brush holder-voltage regulator |
| 7 | Control side bearing | 16 | Brush spring |
| 8 | Plate | 17 | Brush |
| 9 | Feather key | | |

MARELLI ALTERNATOR

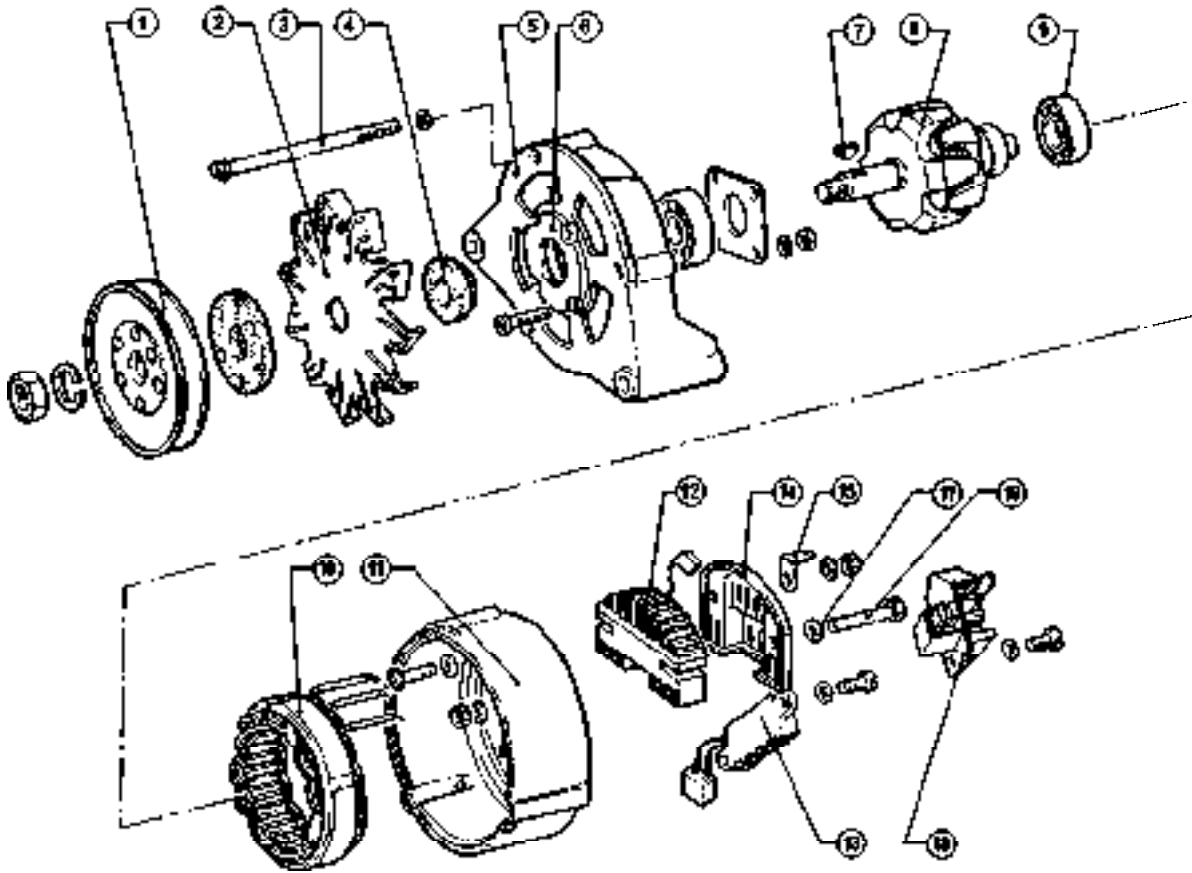

- | | | |
|----------------------------------------|------------------------------|---------------------------|
| 1 Pulley | 7 Feather key | 13 Brush holders |
| 2 Cooling fan | 8 Rotor | 14 Rectifier bridge guard |
| 3 Stay bolt | 9 Bearing-regulator side | 15 Excitation Tang |
| 4 Distance piece | 10 Stator | 16 Positive terminal |
| 5 Drive housing | 11 Voltage regulator support | 17 Insulating washer |
| 6 Bearing retaining plate-control side | 12 Diode rectifier bridge | 18 Voltage regulator |

DISASSEMBLY

CAUTION:

The following procedures are intended for part replacement. If used for component checking and inspection purposes, do not unsolder.

BOSCH ALTERNATOR

1. Hold the alternator pulleys 2 in a vice with caps, Release fan 1 and pulley to rotor shaft 4 securing nut 3. Take off the nut, the lock washer, the two semipulleys with distance pieces and the fan with washers and feather key.

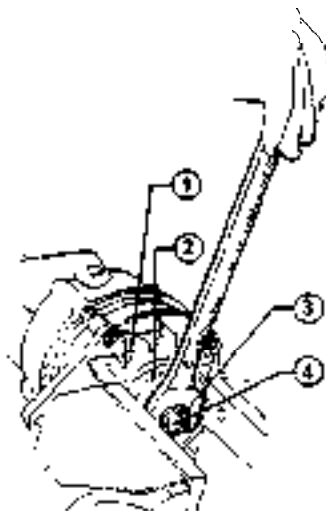

- | | |
|----------|---------|
| 1 Fan | 3 Nut |
| 2 Pulley | 4 Shaft |

2. Unscrew the two screws securing the voltage regulator 1 to its mounting 2 and take out the brush holder regulator unit.



- | |
|----------------------|
| 1 Voltage regulator |
| 2 Regulator mounting |

3. Hold the drive housing (1) in a vice and unscrew the stay bolts clamping the regulator mounting (2) to the housing (1).

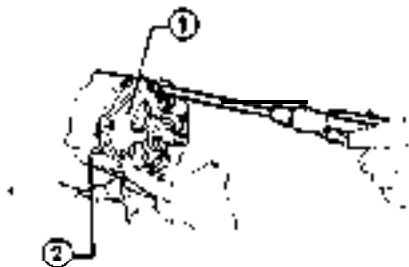

1 Drive housing
2 Regulator mounting

4. Remove the regulator mounting by tapping it on its edge with a plastic hammer as shown in the illustration.

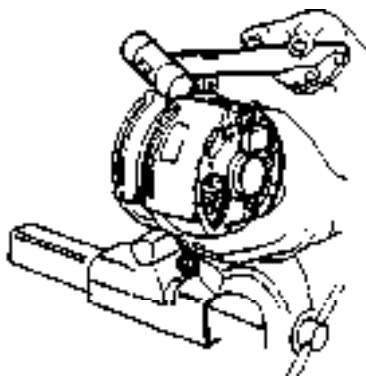

5. Extract the rotor (1) by tapping the rotor shaft (2) on its end with a plastic hammer as shown in the illustration.

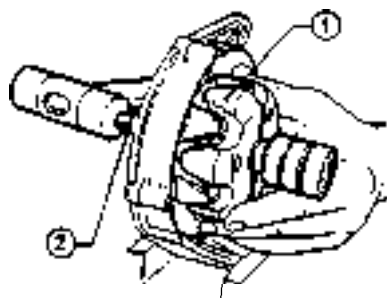

1 Rotor 2 Rotor shaft

6. Unsolder the stator (1) (rotor) three-phase connections to the diode holder plate (2).

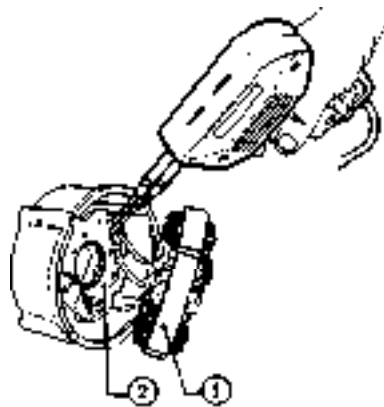

1 Stator
2 Diode holder plate

7. Unscrew the screws (1) securing the diode holder plate to the regulator mounting and extract the diode holder plate.

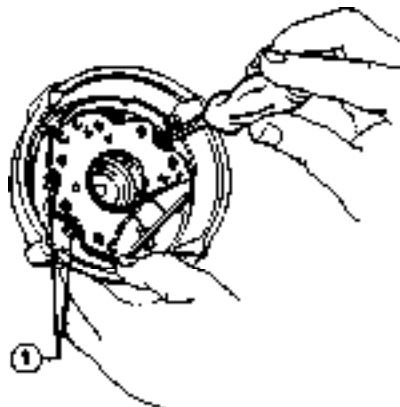

1 Diode holder plate securing screws

8. Unscrew the two screws (1) securing the bearing retaining plate (2) to the drive housing and extract the bearing.

CAUTION :
At reassembly, use a new bearing if the old one is worn or damaged.

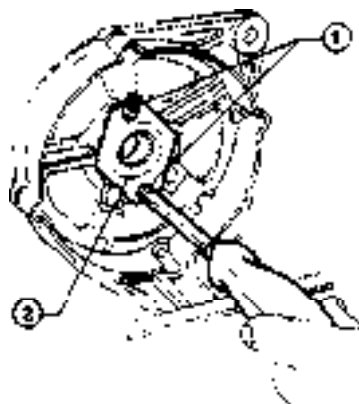

1 Screws 2 Plate

9. Extract the bearing (1) on the drive housing end of the rotor shaft (2) with an extractor (see following figure) or a punch press with half-plates.

CAUTION:

At reassemble use a new bearing if the old one is worn or damaged and put it on the press with the help of a pipe which must rest only on the inner ring of the bearing.

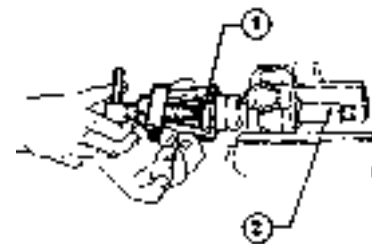

1 Bearing 2 Shaft

DUCELLIER ALTERNATOR

1. Hold the alternator in a vice with caps. Unscrew the screws (1) and (2) securing the voltage regulator (3) to its mounting and extract the voltage regulator.

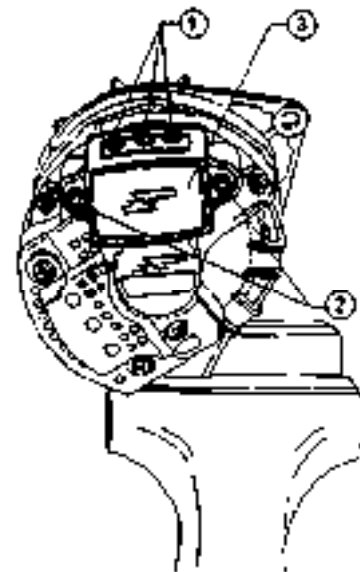

1 Top screws 3 Voltage regulator
2 Side screws

2. Unscrew the two screws (2) securing the brush holder (1) and the earthing plate (4).

3. Unscrew the cable terminal securing screw (3) and take out the brush holder.

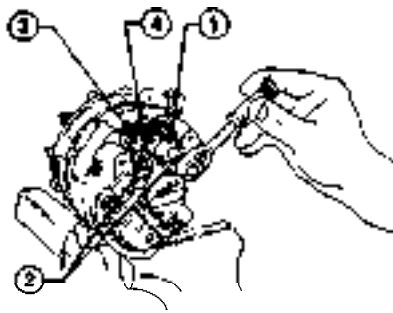

1 Brush holder 3 screw
2 Screws 4 Plate

4. Unscrew the two diode cover (2) nuts (3), take out the excitation pin (1) and take off the cover.

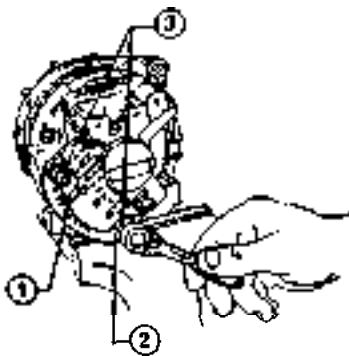

1 Pin 3 Nuts
2 Cover

5. Unscrew the alternator charge indicator pin (1) screw,
6. Unscrew the three alternator pack assembly stud bolts nuts (2).

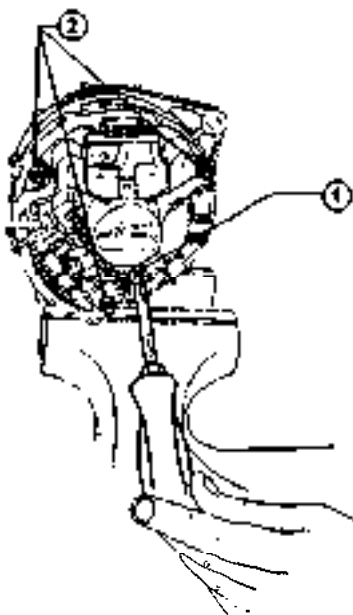

1 Pin 2 Nuts

7. Remove the regulator mounting complete with stator and rectifier bridge (the diode plate) by tapping it on its edge with a plastic hammer.



8. Unsolder the stator three-phase connections to the rectifier bridge tabs.

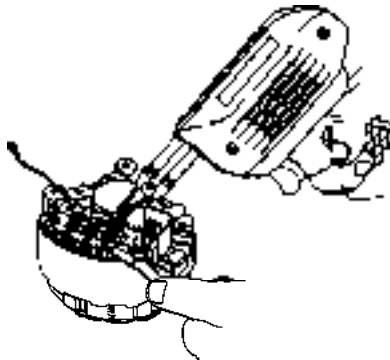

9. Hold the rotor in a vice with caps. Unscrew the nut securing the pulley (1) and the fan (2) to the rotor shaft. In order take off the nut, the washer, the distance piece, the pulley, the second distance piece and the fan with washers and feather key.

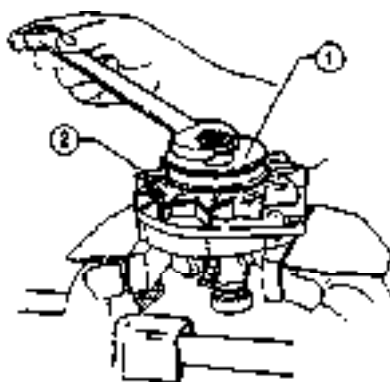

1 Pulley 2 Fan

10. Extract the rotor (1) by tapping the end of the shaft with a plastic hammer as shown in the illustration.

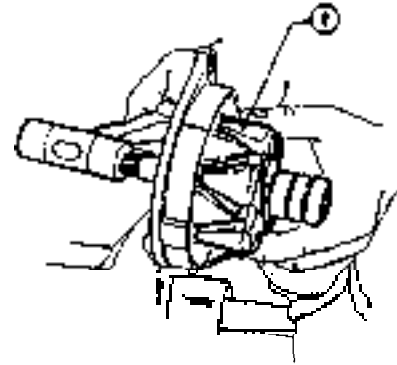

1 Rotor

11. Unscrew the three screws securing the bearing retaining plate to the drive housing and extract the bearing (see: Bosch Alternator - step 6).
12. Take the bearing off the drive housing side of the rotor shaft (see: Bosch Alternator - step 7).

MARELLI ALTERNATOR

1. On a vice fitted with protective jaws, secure pulley (1) of alternator. Loosen nut (2) securing pulley and fan (3) to rotor shaft (4); remove nut, washer, pulley and fan together with spacers and feather.

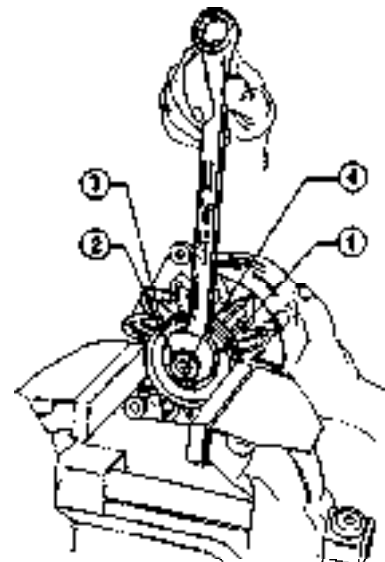

1 Pulley 3 Fan
2 Nut 4 Shaft

2. Disconnect voltage regulator connectors ① and ② of rectifier bridge. Unscrew screw securing brush holder ④ to voltage regulator support ③ and withdraw it.

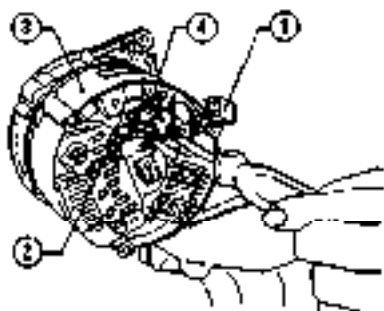

- 1 Voltage regulator
- 2 Rectifier bridge connector
- 3 Rest voltage regulator
- 4 Sliding brush holder

3. Unscrew tie rods ① assembling control support ② to voltage regulator support ③.

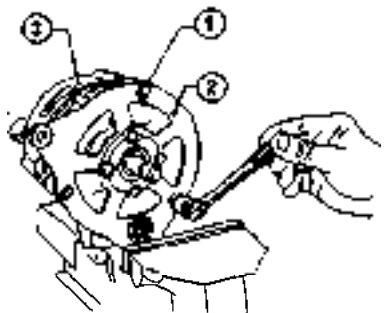

- 1 Tie rod
- 2 Control support
- 3 Voltage regulator support

4. Remove voltage regulator support by hammering on its edge by means of a plastic hammer, as shown in figure.

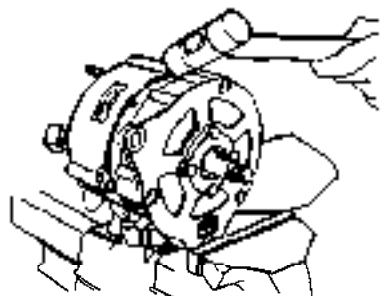

5. Withdraw rotor ① hammering by means of a plastic hammer on shaft ② of rotor itself, as shown in figure.

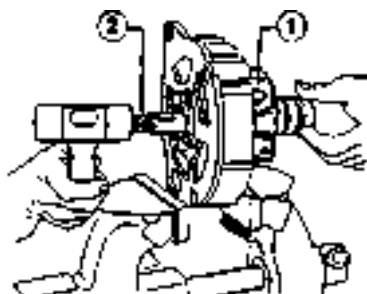

- 1 Rotor
- 2 Shaft

6. Unscrew nut and screw of rectifier bridge guard ①; withdraw power pin ② and remove guard.

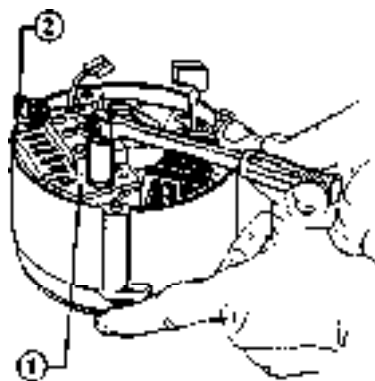

- 1 Guard
- 2 Pin

7. Unsolder connections of stator three phases to finned rectifier bridge,

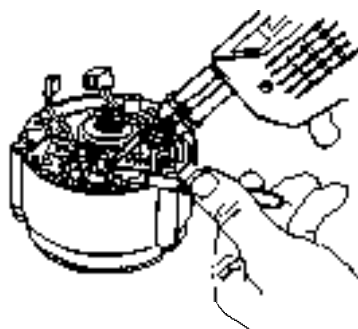

8. Withdraw rectifier bridge and stator from voltage regulator support; then unscrew positive terminal with relevant washer.

9. By means of an extractor (see: Regulator Alternator Bosch) or a

suitable press with plates and punch, withdraw bearing on voltage regulator support side from rotor shaft.

CAUTION:

On reassembly, use a new bearing (in case bearing is damaged or worn) by mounting it on press with the aid of a tube which must face bearing retaining ring.

10. On a vice fitted with protective jaws, tighten control support ①.
11. By means of a drilling machine, remove then rivets ② securing plate ③ retaining bearing to control support.

12. Withdraw bearing.

CAUTION:

On reassembly, use a new bearing, in case the removed one is damaged or worn.

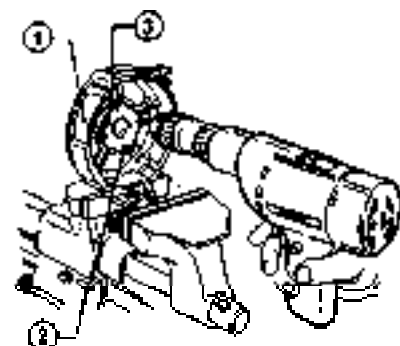

- 1 Control support
- 2 Rivets
- 3 Plate

CHECKS AND INSPECTIONS

CAUTION:

Before starting electrical checks blow-clean all the components thoroughly with compressed air.

1. Slip rings

- (1) Inspect for wear,
- (2) If the rings are scored, but not badly, put the rotor on a lathe and rectify the rings with rotor cloth. If the rings are badly scored, put in a new rotor.

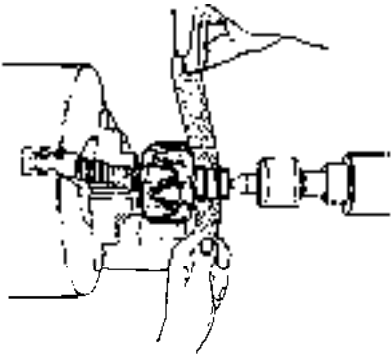

2. Rotor winding continuity test

- (1) Set the tester to the $\Omega \times 1$ scale.
- (2) Put the prods on the slip rings.
- (3) Winding resistance should be:

Bosch alternator $4 \pm 0.1 \Omega$
 Marelli alternator $3.1 \pm 0.2 \Omega$
 Ducellier alternator $6.5 \pm 0.2 \Omega$

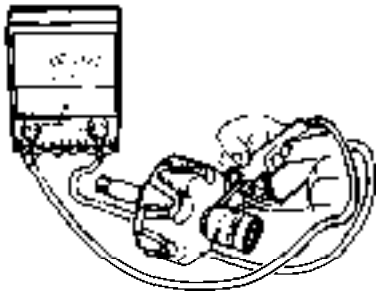

(4) If there is no electrical continuity, put in a new rotor.

3. Rotor insulation test

- (1) Set the tester to the $\Omega \times 1$ scale.
- (2) Put one prod on a slip ring and the other prod on the rotor core. (Repeat for the other slip ring).
- (3.) The tester should show no sign of current flow.

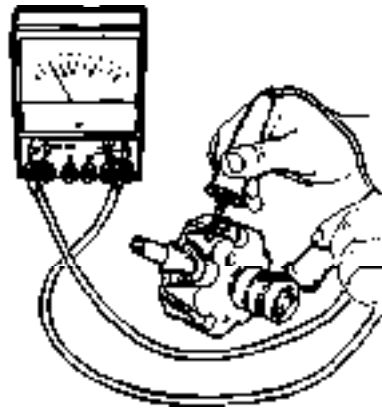

(4) If the insulation is broken, put in a new rotor.

4. Stator windings insulation test

- (1) Set the tester to the $\Omega \times 1$ scale.
- (2) Put one prod on the stator pack and the other prod on the terminals ① of the first phase, then of the second phase, and finally of the third phase.
- (3) The tester should show no sign of current flow.

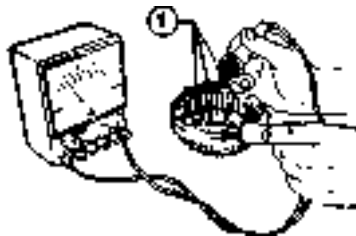

① Phase terminals

(4) If there is insufficient insulation, put in a new stator.

5. Stator windings continuity test

- (1) Set the tester to the $\Omega \times 100$ scale.
- (2) Test for electrical continuity between: 1-2, 1-3, 2-3.
- (3) In each case the tester should show current flow.

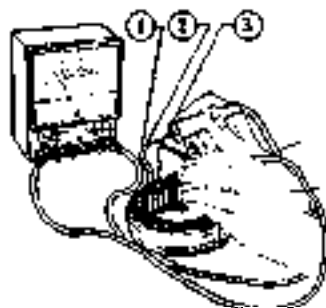

(4) If there is no continuity in the windings, put in a new stator.

6. Brush wear inspection

6-1. Bosch Alternator

- (1) The brushes in the voltage regulator should not be chipped or dirty with carbon deposits; their lengths should be within the prescribed limits.

Brush projection min.
 5 mm (0.197 in)

- (2) In case of excessive wear, unsolders the brush cable as shown in the illustration and put in new brushes.

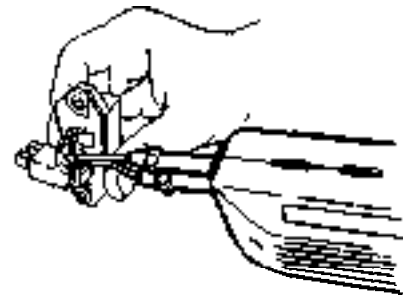

6-2. Ducellier Alternator and Marelli

- (1) The brushes in the brush holder should not be chipped or dirty with carbon deposits; their lengths should be within the prescribed limits.

Brush length min.

Ducellier Alternator 6 mm (0.236 in)
 Marelli Alternator 7 mm (0.275 in)

- (2) In case if excessive brush wear, put in new brushes: the one by simply withdrawing it from its seat on the brush holder and the other by withdrawing it after unscrewing its securing screw.

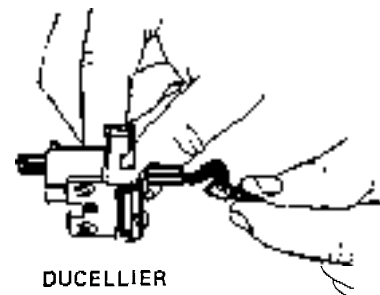

7. Brush spring inspection
The brush springs should be stiff enough to assure good brush contact on the slip rings. If they are not, put in a new voltage regulator unit.
8. Brush holder unit electrical continuity inspection
- (1) Set the tester to the $\Omega \times 100$ scale.
 - (2) Put one prod on one and then on the other brush ①.
 - (3) Put the other prod on the terminal ②.
 - (4) The tester should show current flow.
 - (5) If there is no electrical continuity, check the brush holder and if necessary put in new brushes and/or brush holder.

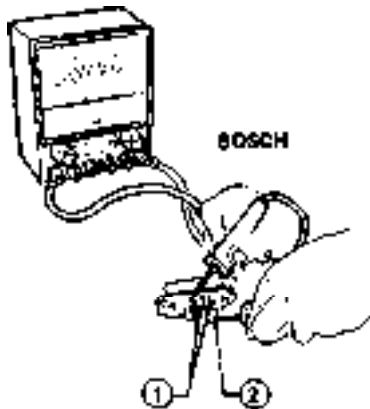

1 Brushes 2 Terminal

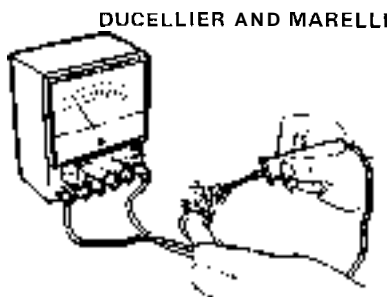

9. Diodes inspection

9-1 Bosch Alternator

- (1) Set the tester to zero on the $\Omega \times 1$ scale.
 - (2) Put the prods on a diode terminals.
- Then either:
- (2a) The tester shows no current flow (infinite resistance).

Inverse current resistance
 $R = \infty$

Reverse the two prods The tester should show the prescribed resistance.

Direct current resistance
 $R = 0 \div 10 \Omega$

(2b)The rester shows current flow and therefore the prescribed resistance.

Reverse the prods and the tester shows no current flow (infinite resistance).

CAUTION:

All excitation diodes must be tested in this way.

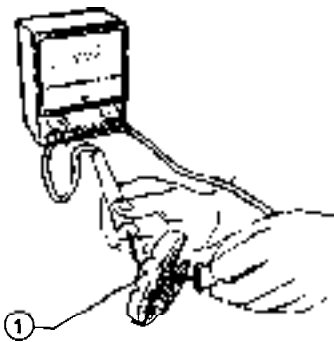

1 Diode holder plate

(3) If the tester readings are not those prescribed, put in a new diode holder plate.

9-2. Ducellier Alternator and Marelli

Power diodes - Bridge direct rest

- (1) Zero tester in the $\Omega \times 1$ range scale.
- (2) Carry out direct test of positive bridge, by setting the tester negative probe on positive heat sink of bridge and the other probe, sequentially, on each end of the three phases of bridge. Check, on tester, that resistance value for direct current is the required one.
- (3) Carry out direct test of negative bridge, by setting the tester positive probe on negative heat-sink of bridge and the other probe, sequentially, on each end of the three phases of bridge. Check on tester, that resistance values is the required one.

Diode resistance in direct conduction

$R = 0 \div 10 \Omega$

Power diodes - bridge inverted test

- (1) Zero tester in the $\Omega \times 100$ range scale.
- (2) Carry out inverted-test of bridge operating as per direct test, by inverting (in sequence) probes between positive heat sink and the three phases of bridge when testing positive bridge. Inverts (in sequence) probes between negative heat sink and the three phases when testing negative bridge.
- (3) Verify on tester that current is not present.

Diode resistance for inverted conduction

$R = \infty \Omega$

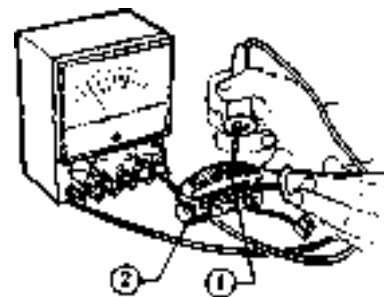

1 Positive heat sink
2 Negative test sink

Energization Diode Direct test

- (1) Zero tester in the $\Omega \times 1$ range scale.
- (2) Connect tester negative probe with output of energization diodes (terminal D+) and second probe (in sequence) with the three phases.
- (3) Verify on tester, that resistance values for direct current are the required ones.

Diode R for direct current

$R = 0 \div 10 \Omega$

Energization Diodes Inverted test

- (1) Zero rester in the $\Omega \times 100$ range scale.
- (2) Operate as per direct test by inverting tester probes between output of energization diodes (terminal D+) and the three phases (in sequence). Verify, on tester, that current is not present.

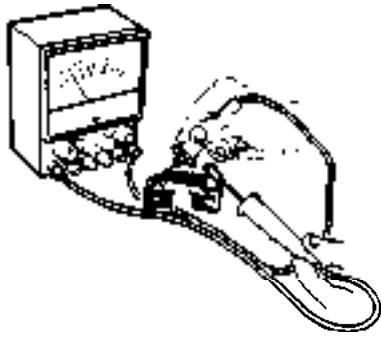

CAUTION :
If the required resistance values are not measured, replace rectifier bridge.

REASSEMBLY

Reassemble the alternator following the disassembly steps in the opposite order, and taking care that:

CAUTION:
When soldering the three stator cables on to the diode holder plate and, for the Bosch Alternator, changing the brushes, the soldering must be done as quickly as possible so the diodes are not overheated.

TEST STAND INSPECTION

1. Put the alternator on the test stand and connect it to the stand's electric motor.
2. Make the following electrical connections:
 - (1) Terminal B+ to test stand positive.
 - (2) Terminal B+ to the pilot light and to terminal D+.
 - (3) Connection for test stand feet.

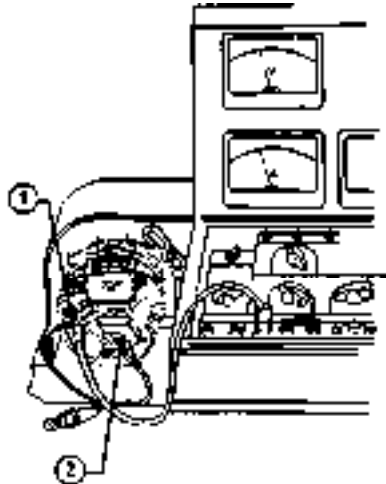

1 Terminal B + 2 Terminal D +

3. Let the alternator rotate at 3,000 rpm for an hour with rheostat load to give a voltage of $13 \div 14V$.
4. Slow down the motor until the current output is from $1 \div 2 A$ and then disconnect load rheostats to get a voltage again of $13 \div 14V$. Take the current reading and the corresponding rpm.
5. Keeping the voltage constant, vary the speed and the load rheostats and take current readings together with the corresponding rpm at different point up to max current output.
6. The output current readings at the various speeds should all be equal to or greater than those reported in the Technical Data.

SERVICE DATA AND SPECIFICATIONS

TECHNICAL DATA AND INSPECTIONS

Alternator	Alfa Romeo Cladd	636.800	643.130	637.004
	Type	BOSCH 0.120.489.798	DUCELLIER	MARELLIA 125 - 14V - 45A
Nominal Voltage	V	-	-	14
Voltage range	V	-	13,75 ÷ 14,35	-
Current output	Max current output	A	45	45 (1)
	Output starts	rpm	1250	1100 (1)
	2/3 max output	rpm	2400	2300 (1)
	max output	rpm	3000	3000 (1)
Brush wear limit	mm (in)	5 (0.197)	6 (0.236)	7 (0.276)
Rotor winding resistance	Ω	4 ± 0.1	6.5 ± 0.2	5.1 ± 0.1
Voltage regulator resistance	Ω	58 ÷ 72	-	-
Diodes resistance	Ω	0 ÷ 10	0 ÷ 10	0 ÷ 10

(1) Minimum readings when hot after 1 hours working at 5000 rpm with loading of 25 A

IGNITION, STARTING, CHARGING SYSTEM

TROUBLE DIAGNOSIS **AND CORRECTIONS**

Before starting alternator troubleshooting, the battery should be fully charged (see: Battery)

Condition	Probable cause	Corrective action
Alternator does not charge	<ul style="list-style-type: none"> • Slack belt • Broken charging or earthing circuit • Faulty brushes • Excitation diodes short circuited • Broken excitation circuit • Broken rotor winding • Inefficient voltage regulator • Stator winding earthed 	<p>Tension the belt</p> <p>Check the circuit</p> <p>Put in new brushes</p> <p>Put in new diode holder plate</p> <p>Check the circuit</p> <p>Put in new rotor</p> <p>Put in new voltage regulator</p> <p>Put in new stator</p>
Insufficient or irregular output	<ul style="list-style-type: none"> • Slack belt • Intermittent break in the charging circuit • Worn brushes • Inefficient voltage regulator • An excitation diode disconnected or earthed • Rotor partly short circuited • Stator disconnected, earthed or partly short circuited 	<p>Tension the belt</p> <p>Check the circuit</p> <p>Put in new brushes</p> <p>Put in new voltage regulator</p> <p>Put in new diode - holder plate</p> <p>Put in new rotor</p> <p>Put in new stator</p>
Excessive output	Inefficient voltage regulator	Put in new voltage regulator
Noisy alternator	<ul style="list-style-type: none"> • Worn belt • Loose pulley • Poor bearings • An excitation diode short circuited • Loose alternator 	<p>Put in new belt</p> <p>Tighten up the nut</p> <p>Put in new bearings</p> <p>Put in new diode-holder plate</p> <p>Tighten up the screws on the bracket</p>

DESCRIPTION

The electronic ignition is an inductive discharge transistorized system without contacts, constituted by the following components.

- a. ignition distributor with magnetic pulse generator (A5) with mechanic centrifugal spark advance and vacuum advance calibrator.
- b. Ignition coil (A8) with electronic module.
- c. Electronic module (N1)

The ignition distributor with magnetic pulse generator differs from the traditional type as, in the place of contacts and of capacitor, it has a magnetic pulse generator (stator) and, in the place of the cam, a toothed timer (rotor).

High voltage distribution to spark plugs is obtained by means of a rotor

arm and cap. The pulses are generated by a magnetic pulse generator located into a variable air gap circuit. During rotation of distributor shaft, each time a tooth of the timer passes in front of the fixed pole piece expansion, a signal is generated (by induction) at the winding ends of coil (pulse generator), with consequent control of the electronic module.

The electronic module, constituted by a set of integrated circuits mounted onto a ceramic support enclosed into a proof container is, in its turn, mounted together with coil, onto an aluminium finned support which also operates as heat dissipator. Between the electronic module and the support, it is interposed a grease coat with thermal high conductivity, with the purpose of ensur-

ing heat maximum elimination and stable performances.

Besides conducting or interdicting the output transistor, the electronic module has also the purpose of processing the signal provided by the magnetic pulse generator of distributor, conducting one linked with the engine rotation revolution numbers. It is thus obtained a control of the coil charge current and of time duration of conduction with generation of constant energy spark, independently of engine speed and battery voltage.

A coupling capacitor, secured to module radiator and electrically connected with coil terminal and to ground, allows optimization of primary voltage wave form on coil and, consequently, higher performances.

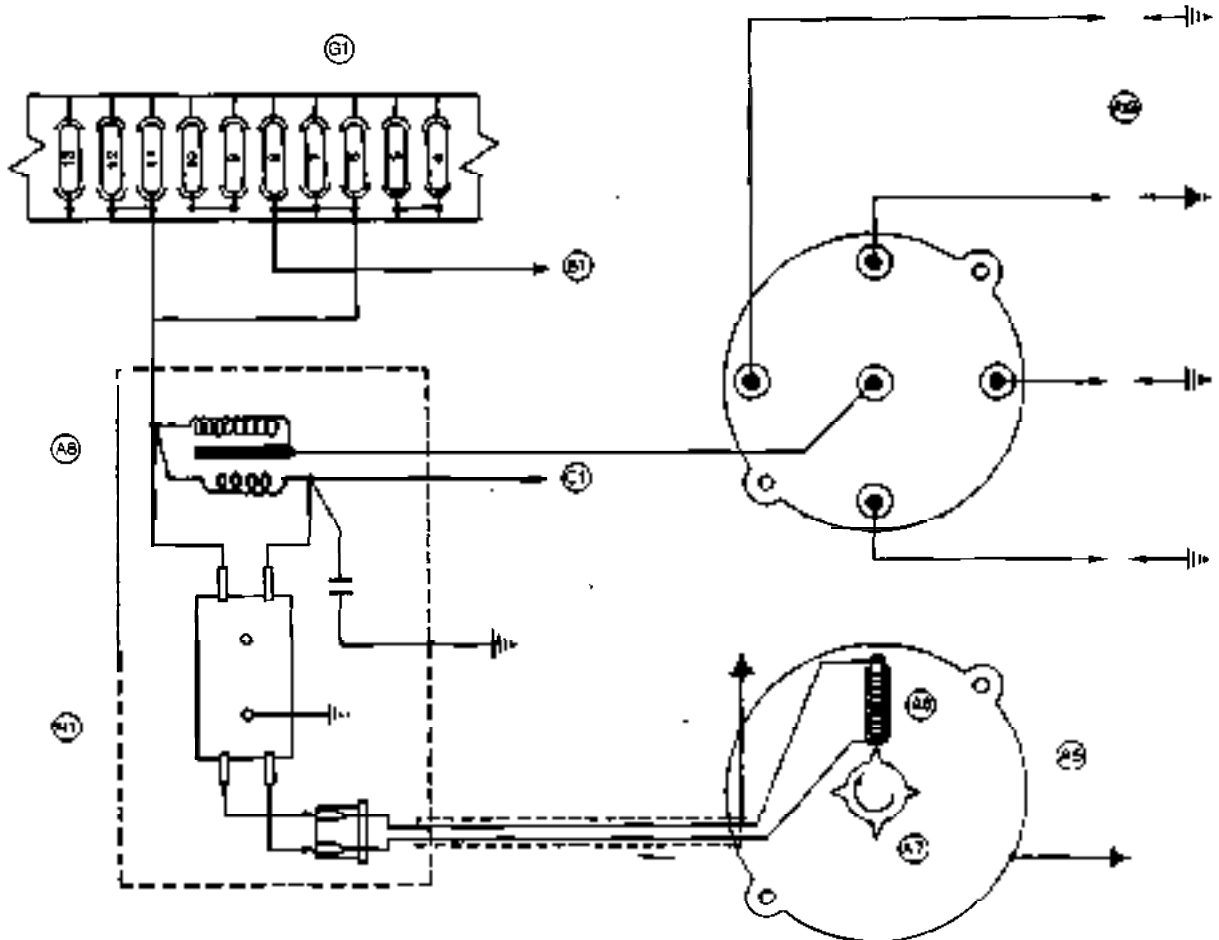

- G1. Fuseholder box
- B1. To ignition switch
- A1 2. Spark plugs
- C1. To electronic tachometer
- A6. Magnetic pulse generator

- A7. Timer (Rotor)
- A5. Electronic distributor
- N1. Electronic Module
- A8. Ignition coil

CHECKS AND ADJUSTMENTS ON CARS

1. Check general rules

CAUTION:

Each check for presence of voltage or current in electric connections, via sparking, that is, ground discharging the high-and low voltage points, must be avoided unless they are required special verifications expressly listed with application of special devices. Besides, the following operations must be avoided:

- Connection interruption between tap of coil high voltage and distributor, by disconnecting the relevant cable (coil side) when motor is running or during starting phase.
- Ground connection of coil low voltage terminal connected with tachometer.
- Use of trouble diagnosis equipments which allow the short-circuit the low voltage signal, between coil primary winding and tachometer or not allowed.

WARNING:

Before powering the unit, make sure that connectors of the electric system are properly inserted and that the module coil units is secured to ground so as to ensure an effective connection.

WARNING:

Stroboscopic gun must always be directly connected with battery terminals.

2. System functioning verification

- (1) With ignition key inserted (ignition switch closed) and engine still, check, by means of voltmeter, that the voltage on terminal 15 of coil is equal to the battery voltage (12V).
- (2) After carrying out the ignition timing operation (for timing see: Group 00 Ignition System and Supply) check possible interruptions in the coil windings. To this purpose, disconnect the tachometer cable and, with non-inserted ignition key, check via ohmmeter, that resistance values of both primary and secondary windings are the prescribed ones.

Coil		Marelli	Bosch
Primary winding resistance	Ω	$0.72 \pm 10\%$	0.7 ± 10
Secondary winding resistance	Ω	$7000 \pm 10\%$	$6700 \pm 10\%$

- (3) With ignition key not inserted (ignition switch open) verify functioning of ignition distributor by disconnecting the connector between module coil unit and distributor and checking via ohmmeter, that resistance of pulse generator coil corresponds to the prescribed value.

Distributor		Marelli	Bosch
Pulse generator for coil resistance	Ω	$730 \pm 5\%$	$1100 \pm 10\%$

- (4) Verify that resistance internal to rotor arm of ignition distributor corresponds to the prescribed value.

Distributor		Marelli	Bosch
Rotor arm resistance	Ω	5,000	1,000

- (5) Proceed as follows for system general verification with ignition key not inserted, disconnect from a spark plug the connection high voltage cable to distributor by setting the free end at 5 mm (0.2 in) from engine body.

WARNING:

Put on insulation gloves and start the engine verifying that spark occur regularly between cable and ground.

IGNITION, STARTING, CHARGING SYSTEM

BOSCH DISTRIBUTOR

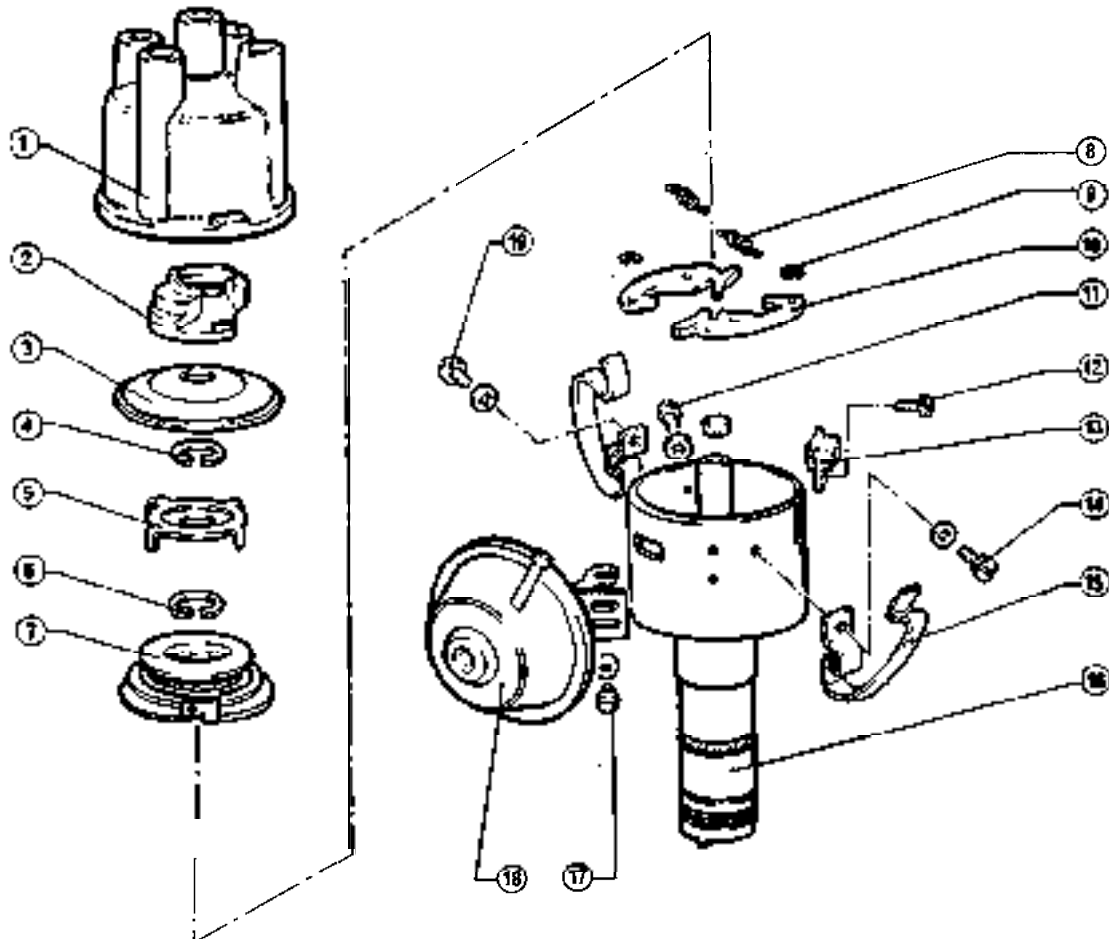

- | | | | |
|----|--------------------------|----|--------------------------------|
| 1 | Cap | 11 | Pulse generator securing screw |
| 2 | Rotor arm | 12 | Connector securing screw |
| 3 | Dust cover | 13 | Connector |
| 4 | Retaining ring | 14 | Spring securing screw |
| 5 | Timer | 15 | Spring |
| 6 | Retaining ring | 16 | Distributor body |
| 7 | Pulse generator (stator) | 17 | Advance regulator |
| 8 | Spring | 18 | Advance regulator |
| 9 | Retaining ring | 19 | Spring securing screw |
| 10 | Counterweight | | |

MARELLI DISTRIBUTOR

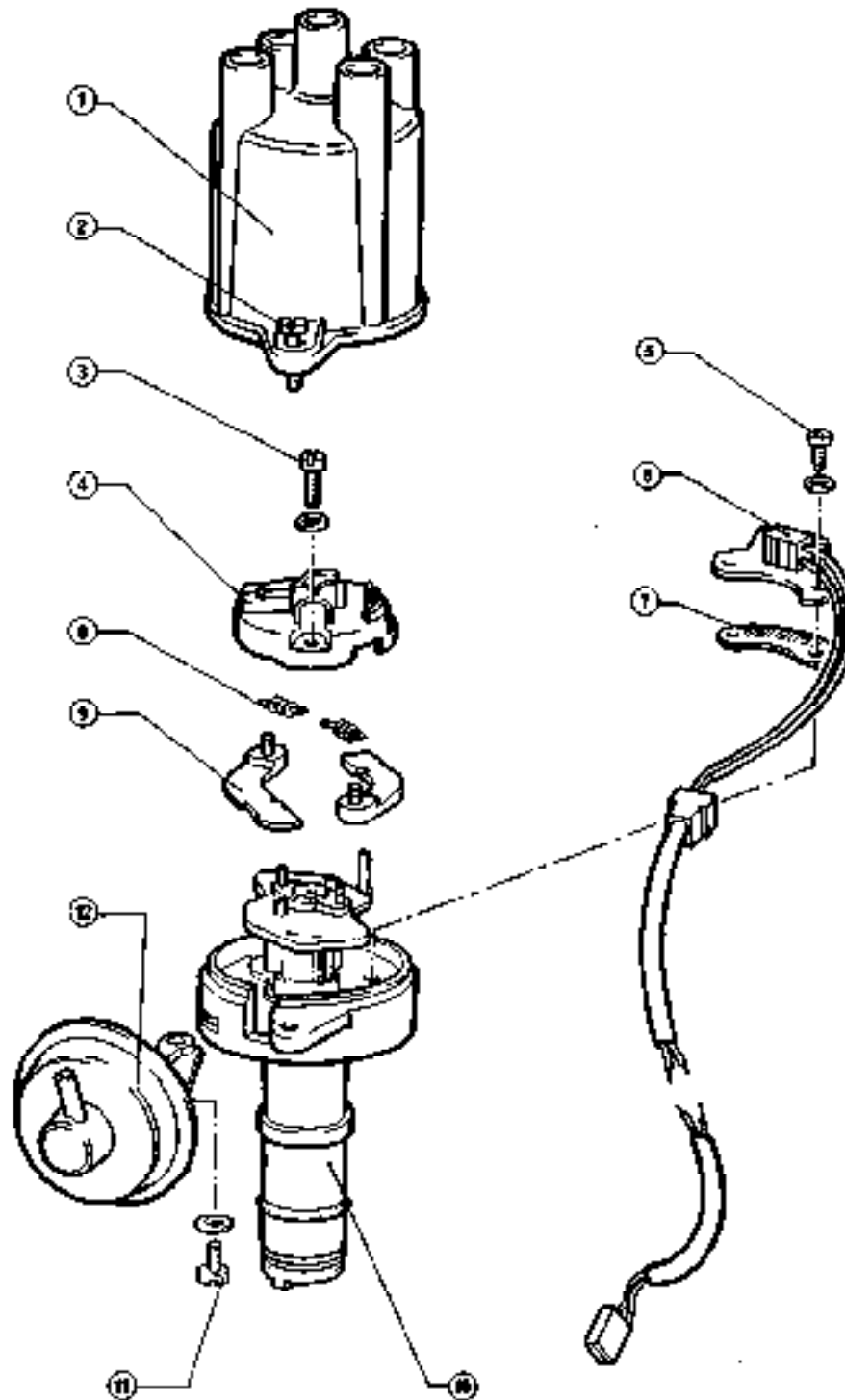

- | | |
|----------------------------------|-------------------------------------|
| 1 Cap | 7 Insulating support |
| 2 Cap securing screw | 8 Spring |
| 3 Rotor arm securing screw | 9 Counterweight |
| 4 Rotor arm | 10 Distributor body |
| 5 Pulse generator securing screw | 11 Advance regulator securing screw |
| 6 Pulse generator (stator) | 12 Advance regulator |

DISASSEMBLY

In the following are provided the disassembly operations relevant to ignition distributors, limited to the part on which maintenance is carried out.

BOSCH DISTRIBUTOR

Clamp distributor on a vice fitted with protective jaws.

1. Remove cap ① and withdraw first the rotor arm ② with rev limiter and then the lubrication felt.

The rev limiter is a centrifugal located on the head of rotor arm which interrupts the ignition distribution when the engine exceeds 6800 rpm.

2. Remove dust cover ③.

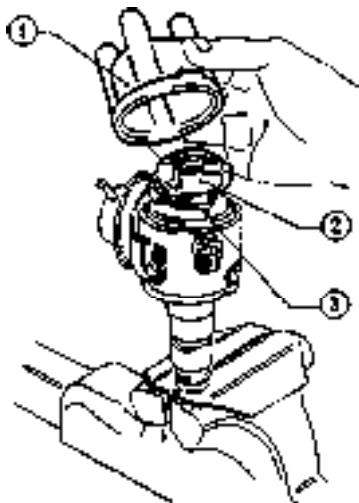

1 Cap
2 Rotor arm
3 Dust cover

3. Operating as per figure, remove retaining ring of timer.

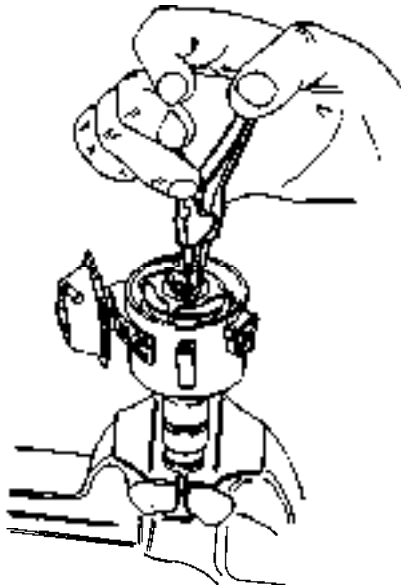

4. Remove cap securing springs ④ after unscrewing the relevant screws ②. Then unscrew ① securing stator to distributor body and screws ③ securing advance regulator to distributor body.

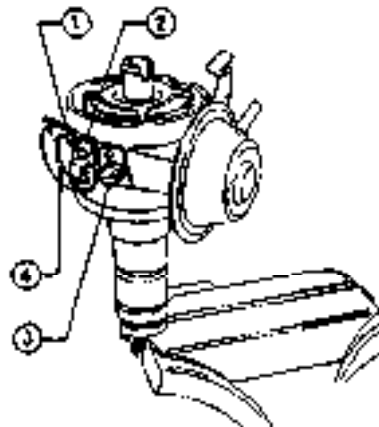

1 Stator securing screw
2 Spring securing screw
3 Regulator securing screw
4 Spring

5. Operating on screw ①, remove connector ② of distributor body.

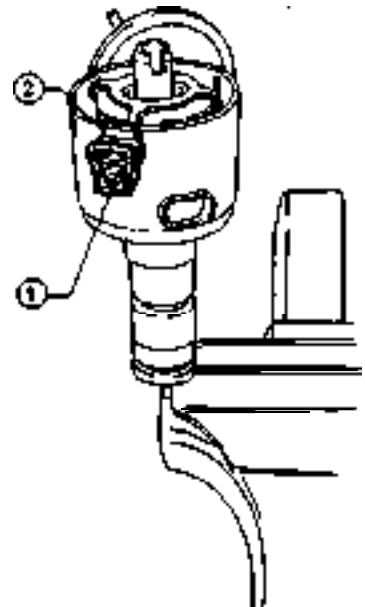

1 Screw
2 Connector

6. Lift inductive winding ①, then remove the advance regulator ②.

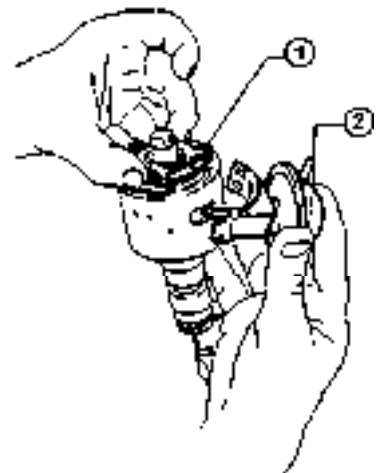

1 Inductive winding
2 Advance regulator

7. From distributor shaft, remove in sequence the timer, retaining ring ① and inductive winding ② complete of stator and supporting plate.

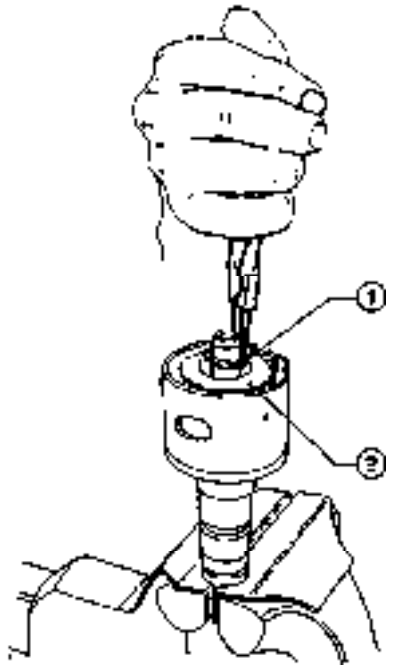

1 Retaining ring 2 Inductive winding

8. By means of a clamp, release springs (2) of counterweights 1, then remove stop retaining rings 3 and then withdraw counterweights.

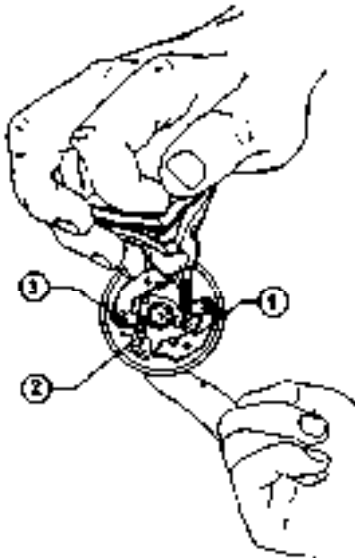

1 Counterweights 3 Retaining ring
2 Springs

MARELLI DISTRIBUTOR

Clamp distributor on a vice fitted with protective jaws.

1. Unscrew screws (4) securing cap to distributor body; then withdraw cap (1).

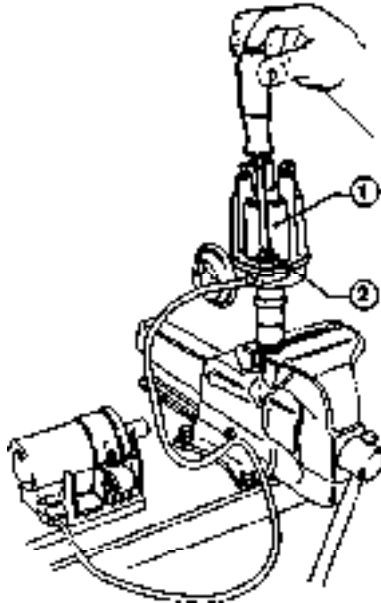

1 Cap 2 Securing screws

2. Unscrew screws (4) securing rotor arm to body; then withdraw rotor arm (1).

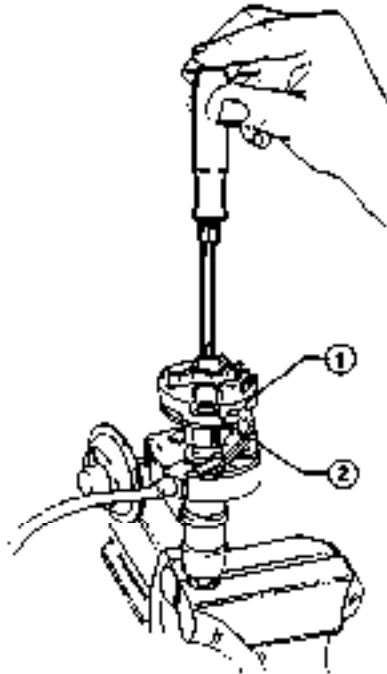

1 Rotor arm 2 Securing screws

3. Withdraw springs (2) and remove counterweights (1).

4. Unscrew securing screws 4, then remove pulse generator 3 (stator) and magnetic insulating support (5).

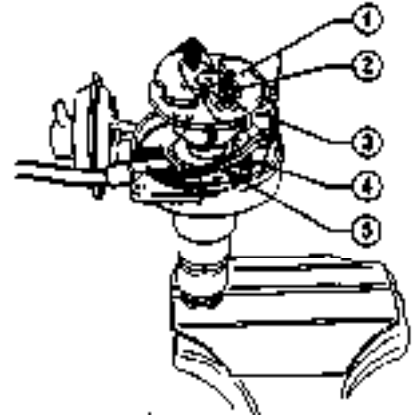

1 Counterweights 4 Screws
2 Springs 5 Insulating support

5. Unscrew the four screws securing advance regulator to lower base of distributor body, then withdraw body from its seat by using as fulchrum the regulator shaft.

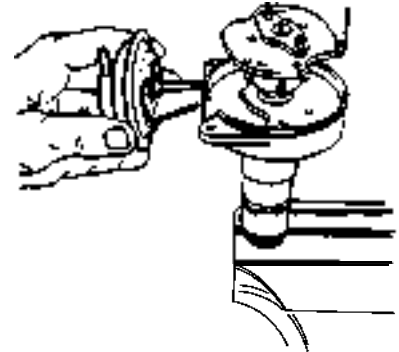

CHECKS AND INSPECTIONS

MARELLI DISTRIBUTOR

By means of a feeler gauge, verify that air gap between pulse generator (2) and timer (1) corresponds to the "S" prescribed value.

$$\text{Air gap} \\ S = 0.4 \div 0.5 \text{ mm } (0.016 \div 0.02 \text{ id})$$

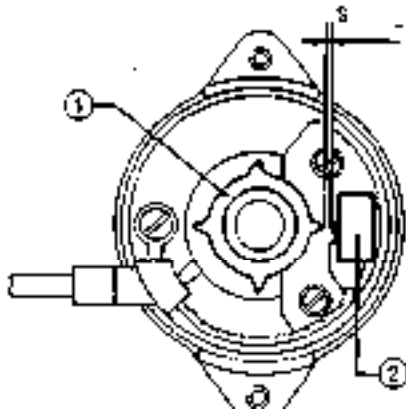

1 Timer

2 Pulse generator

CAUTION:

Marelli Distributor

Every time it is carried out a disassembly or replacement operation of magnetic pulse generator, it is anyway required to reassemble the magnetic spacer of pulse generator support.

TEST STAND INSPECTIONS

1. Vacuum advance

(1) Mount the ignition distributor on a test bed and carry out electric connections.

(2) Carry out spark resetting on goniometer disc of test bed by rotating distributor manually or with the test bed motor without exceeding 50 r.p.m. speed.

(3) Carry out connection of vacuum pipe to vacuummeter of test bed.

(4) On increasing vacuum, read the advance curve (see Service Data and Specifications).

(5) If the read curve is not within the prescribed deviations, replace the vacuum advance device.

2. Counterweights advance

(1) Carry out steps 1 and 2 relevant to vacuum advance verification.

(2) On vacuum spark advance control disconnected from test bed vacuummeter, read, on increasing r.p.m., the automatic advance curve (see: Service Data and Specifications).

(3) If the particulars are not within the prescribed values, carefully examine the distributor and, particularly the counterweights and relevant return springs, timer, and pulse generator. Replace faulty the parts.

REASSEMBLY

For reassembly reverse the order of disassembly and comply with the following:

1. **Lubricate** the following components by means of distributor special grease.

- Counterweights springs
- Counterweights

2. **Lubricate** felt of distributor shaft with few oil drops.

SERVICE DATA AND SPECIFICATIONS

TECHNICAL DATA AND INSPECTIONS

Ignition Distributor

Alfa Romeo Class		542.168	542.161
Type		MARELLI SM 802 AX	BOSCH 0.237.005.004
Firing order		1 - 3 - 2 - 4	
Pulse Generator Coil Resistance	Ω	730 \pm 5%	1100 \pm 10%
Internal resistance of distributor 1 rotor arm	Ω	5000	1000
Air gap	mm (in)	0.4 \div 0.5 (0.015 \div 0.019)	

ELECTRONIC MODULE

Supply voltage	V	4 \div 16
Maximum controllable current	A	6
Radiator limit temperature		- 30 \div + 185°C (- 22 \div + 365°F)

IGNITION, STARTING, CHARGING SYSTEM

AUTOMATIC AND PNEUMATIC ADVANCE CURVES

BOSCH			MARELLI		
Rpm	Automatic advance curve		Rpm	Automatic advance curve	
	Over	Lower		Over	Lower
100	15'	1° 15'	250	0°	0°
270	-30'	45'	450	30'	-1°
370	0°	0°	600	3° 30'	30'
380	30'	-45'	700	5°	2° 15'
420	15'	- 1°	800	6°	4°
500	1° 30'	- 1°	1750	14°	12°
700	4°	2°	2300	14°	12°
800	5° 45'	3° 45'			
1700	13° 45'	11° 15'			
1800	14°	12°			
2500	13°	11°			
3000	12° 15'	10° 15'			

BOSCH			MARELLI		
Vacuum in.Hg	Pneumatic advance curve		Vacuum in.Hg	Pneumatic advance curve	
	Over	Lower		Over	Lower
0	30'	-30'	100	0°	-
90	30'	-30'	150	2° 45'	0°
105	45'	-30'	190	4° 30'	2°
150	7° 45'	-30'	230	6°	3° 45'
180	4°	1°	280	7° 30'	5° 30'
267	7° 30'	4° 45'	300	7° 30'	5° 30'
293	7° 30'	5° 30'			
338	7° 30'	5° 30'			

IGNITION, STARTING, CHARGING SYSTEM

IGNITION COIL

Alfa Romeo Class		542.167	542.162
Type		MARELLI BAE 207B	BOSCH 0.221.600.002
Primary winding resistance	Ω	$0.72 \pm 10\%$	$0.7 \div 1$
Secondary winding resistance	Ω	$7900 \pm 10\%$	$6700 \div 9600$

SPARK PLUGS

Alfa Romeo Class	535.420
Type	LODGE 25 HL

FLUID AND LUBRICANTS

Application	Type	Demmination	Q.ty
Spark plug thread	OIL	ISECO Molykote A Standard 4500 - 18304	

TIGHTENING TORQUES

Item	Unit	N·m	kg·m	ft·lb
Spark plugs in ISECO oil: Molykote A		$25 \div 34$	$2.5 \div 3.5$	$18.08 \div 25.31$

ENGINE COOLING SYSTEM



CONTENTS

COOLING SYSTEM	07-2	ELECTRIC FAN CONTROL	
General description	07-2	THERMAL CONTACT	07-6
Removal	07-3	Removal and installation	07-6
Hydraulic system leak test.	07-3	Checks and inspections	07-6
WATER PUMP	07-3	HEADER TANK PRESSURIZED	
Checks and inspections	07-4	PLUG	07-6
Installation	07-4	Leak test	07-6
THERMOSTAT	07-4	SERVICE DATA AND	
Removal	07-4	SPECIFICATIONS	07-6
Checks and inspections	07-4	Inspection and adjustment	07-7
Installation	07-5	Tightening torques	07-8
RADIATOR	07-5	TROUBLE DIAGNOSIS AND	
Removal and installation	07-5	CORRECTIONS	07-8
Leak test	07-6		

COOLING SYSTEM

GENERAL DESCRIPTION

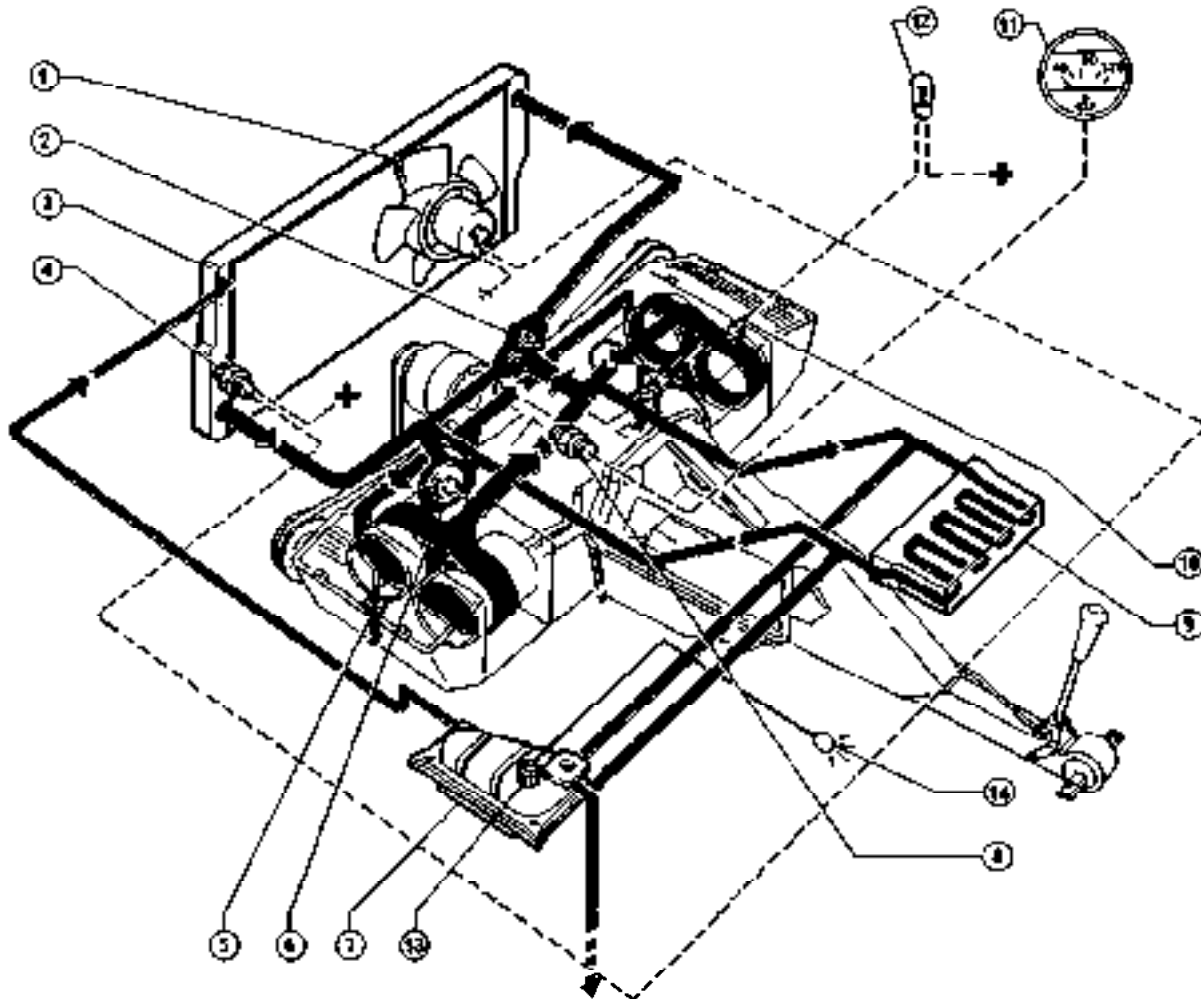

- 1 Electric fan
- 2 Thermostat
- 3 Radiator
- 4 Electric fan thermal contact
- 5 Cooling drain plugs
- 6 Centrifugal pump
- 7 Header tank
- 8 Cooling temperature transmitter
- 9 Heater
- 10 Cooling temperature warning light thermal contact
- 11 Cooling temperature indicator
- 12 Cooling temperature warning light
- 13 Cooling water level sensor for check control
(1 500 Quadrifoglio model)
- 14 Cooling water minimum level warning light
(1500 Quadrifoglio model)

CHECKS AND INSPECTIONS

The water pump cannot be overhauled and in case of failure must be replaced.

1. Check pump body and impeller for indications of wide oxidation and corrosion; if any, replace pump.
2. Verify that there is no excessive play in the rotation and axial movement of impeller.



INSTALLATION

1. Fit water pump with new relevant gasket to block and tighten securing screws to specified torque value.

: Tightening torque
Screws securing water pump
19 ÷ 24 N-m
(1.9 ÷ 2.4 kg-m
13.74 ÷ 17.35 ft-lb)

2. Check correct timing of engine and key camshaft belt on camshaft

pulley. For the timing and belt keying procedure refer to: Group 00 - Engine Maintenance.

3. Refit front cover of camshaft belt, pulley, alternator, pump and alternator driving belt, in reverse order of removal.

4. Stretch pump-alternator driving belt.

For the stretching procedure of belt refer to: Group 00 - Engine Maintenance.

5. At end of pump installation, pour the coolant and letting the engine run for a few minutes check against coolant leakages.

THERMOSTAT

REMOVAL

1. Drain coolant up to the lower level of thermostat housing.
2. Detach coupling ① connecting thermostat cover to radiator.
3. Screw out screws ④ and remove cover ③ with relevant gasket ⑦.
4. Withdraw thermostat ⑥ from housing ⑧.

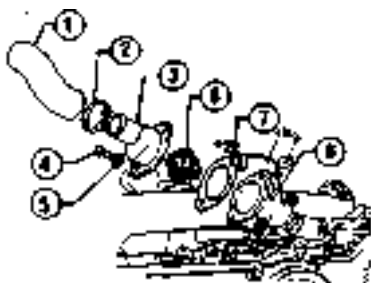

- | | |
|------------|--------------|
| 1 Coupling | 5 Washer |
| 2 Clamp | 6 Thermostat |
| 3 Cover | 7 Gasket |
| 4 Screw | 8 Housing |

CHECKS AND INSPECTIONS

Thermostat should be checked in accordance with the following procedure:

1. Fit thermostat ② to suitable test equipment.
2. Fill container with water and switch on equipment to heat water.
3. Check that, when thermostat opens, temperature value read on thermometer ① dial indicator is 84 ÷ 88°C (183.2 ÷ 190.4°F).
4. Additionally check that thermostat is fully open at 98°C (208.4°F) and valve travel greater than 7 mm (0.28 in).

If above values are not met, thermostat must be replaced.

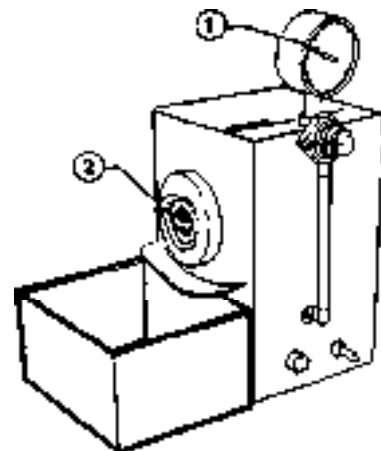

1 Thermometer 2 Thermostat

LEAK TEST

1. Remove radiator from car (Refer to: Radiator Removal and Installation).
2. Close radiator outlet and inlet unions.
3. Immerse radiator in a tank previously filled with water and check for possible leakages inflating

compressed air through radiator breather pipe until a pressure of $98.1 \div 107.9$ kPa; (0.9 \div 1.0 bar; $1 \div 1.1$ kg/cm²; 14.22 \div 15.64 psi) is reached.

4. If leakages are found, clean area to be soldered by a wire brush and deoxidate by "baked" hydrochloric acid (zinc chloride).
5. Solder the leaking area.,

6. Test again radiator for leakages as described above and then refinish radiator with black synthetic enamel. In case of leakages from radiator fitted with side tanks (with gaskets), replace the radiator.

7. Refit radiator to car (Refer to: Radiator - Removal and Installation). Fill with coolant and check for leakages.

ELECTRIC FAN CONTROL THERMAL CONTACT

REMOVAL AND INSTALLATION

1. Drain coolant.
2. Disconnect thermal contact cables.
3. Unscrew thermal contact from radiator.
4. Installation is carried out in reverse order of removal.
5. At the end of installation procedure, fill the circuit with coolant and let the engine rotates until coolant reaches the temperature of $88 \div 92^{\circ}\text{C}$ ($190.4 \div 197.6^{\circ}\text{F}$) and verify that electric fan inserts.

CHECKS AND INSPECTIONS

Check thermal contact according to the following procedure:

1. Fit thermal contact (2) to the test equipment used for thermostat test.
2. Fill container with coolant and switch on equipment to heat water.
3. When warning light (1) illuminates, verify that temperature shown on thermometer dial indicator corresponds to the thermal contact setting value $88 \div 92^{\circ}\text{C}$ ($190.4 \div 197.6^{\circ}\text{F}$).

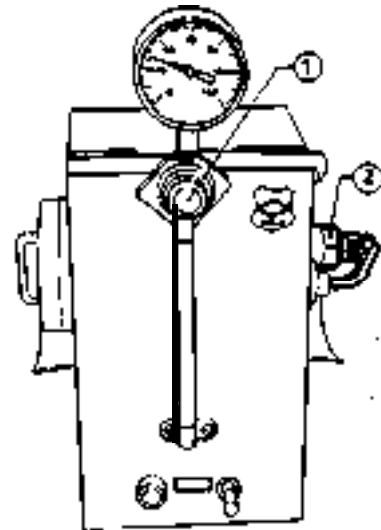

1 Warning light 2 Thermal contact

HEADER TANK PRESSURIZED PLUG

LEAK TEST

1. Screw fitting (1) to test equipment and insert on header tank pressurized plug.
2. Act on tool to increase pressure and check on dial indicator that blowoff valve opens at the required setting pressure.

Pressurized plug setting pressure
 69.6 kPa; (0.69 bar;
 0.7 kg/cm²; 9.95 psi)

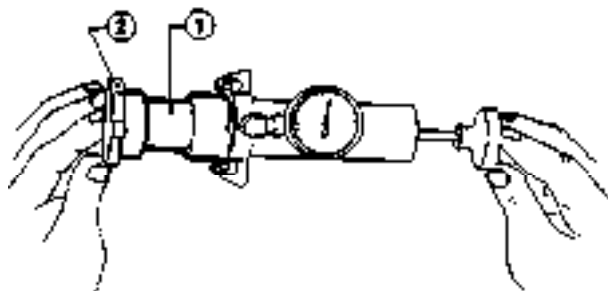

1 Pipe fitting 2 Pressurized plug

SERVICE DATA AND SPECIFICATIONS

INSPECTION AND ADJUSTMENT

BELT TENSIONING

Load to be applied: 78.4 N
(8 kg
17.64 lb)

Resultant arrow 15 mm
(0.6 in)

THERMOSTAT

TEMPERATURE

— Start of opening 84 ÷ 88°C
(183.2 ÷ 190.4°F)

— End of opening 98°C
(208.4°F)

— Bulb travel > 7 mm
(> 0.28 in)

RADIATOR

Radiator leak control pressure 1 07.9 kPa
(1.0 bar;
1.1 kg/cm²;
15.64 psi)

PRESSURIZED PLUG

Pressurized plug setting pressure 68.6 kPa
(0.69 bar;
0.7 kg/cm²;
9.95 psi)

ELECTRIC FAN

Electric fan intervention temperature 88 ÷ 92°C
(190.4 ÷ 197.6°F)

GENERAL SPECIFICATIONS

COOLANT

Summer				
Water		l	7.3	
		Imp. Gall	1.61	
Winter				
Min. temperature	°C	-10	-20	-35
	°F	(14)	(-4)	(-31)
Antifreeze cat. 3 6 6 1 - 6 9 9 5 6 l		1.8	2.6	3.65
	(Imp. gall)	(0.391)	(0.57)	(0.80)
Water	l	5.5	4.7	3.65
	(Imp. gall)	(1.2)	(1.03)	(0.801)
Antifreeze ready for use cat. 3 6 8 1 - 6 9 9 5 8 l		—	7.3	—
	(Imp. gall)	—	(1.6)	—

CAUTION:

Produit harmful to the paint. Avoid contact with painted parts.

COOLING SYSTEM SCALES REMOVER

NALCO: 1006
INTERPOIND: Jal Auto Cat.
3681-69955

SEALING AND FIXING COMPOUNDS

Application	Type	Denomination	Q.ty
Sealing compound for cooling system	Sealing powder	AREXONS Cat. 3522-00101	7.3 g 0.20 (oz)

ALUMASEAL can be used as an alternative.

TIGHTENING TORQUES

	Unit	N·m	kg·m	ft·lb
Cooling temperature transmitter on feeding manifold		33-44	3.4 ÷ 4.2	24.58 ÷ 30.37
Water pump securing screws		19 ÷ 24	1.9 ÷ 2.4	13.74 ÷ 17.35

TROUBLE DIAGNOSIS AND CORRECTIONS

Condition	Probable cause	Corrective action
Water leakage	<ul style="list-style-type: none"> • Radiator damaged • Leaks in system couplings • Loose or broken clamps • Leakages from thermostat • Damaged cylinder head gasket • Loose cylinder head tightening screws 	Repair or replace Repair Tighten or replace Replace gasket or thermostat Replace. Check engine oil for contamination Restore correct tightening
Poor circulation	<ul style="list-style-type: none"> • Pipes obstructed • Insufficient coolant • Inoperative water pump • Water pump and alternator driving belt loosen 	Check pipes and clean system Top up Replace Adjust
Corrosion and scales		Periodically change coolant at intervals recommended. Follow instructions for use shown on packaging.
Overheating	<ul style="list-style-type: none"> • Inoperative thermostat • Dirty and scaled radiator • Ignition out-of-phase • Poor lubrication • Faulty water pump • Insufficient coolant 	Replace Clean pipes flushing with the specified descaling compound. Follow instructions for use shown on packaging. Retime Restore oil level Replace Restore coolant level and check system for leaks

DESCRIPTION

This is a hydraulic controlled, dry, singledisc clutch provided with a thrust bearing (13) which is always in contact with pressure plate spring (15). Diaphragm spring (10) pressure engaged driven plate. Disengagement is obtained by a ped-

al (8) operated through a master cylinder (7) which transmits fluid pressure increase to operating cylinder (3) piston.

The latter operates on the withdrawal lever (9) by a push rod (4),

moves thrust bearing (self centering) and wins diaphragm spring action. By means of gaskets performing on cylinder, piston takes up possible slacks and therefore driven plate wear recovery is automatic.

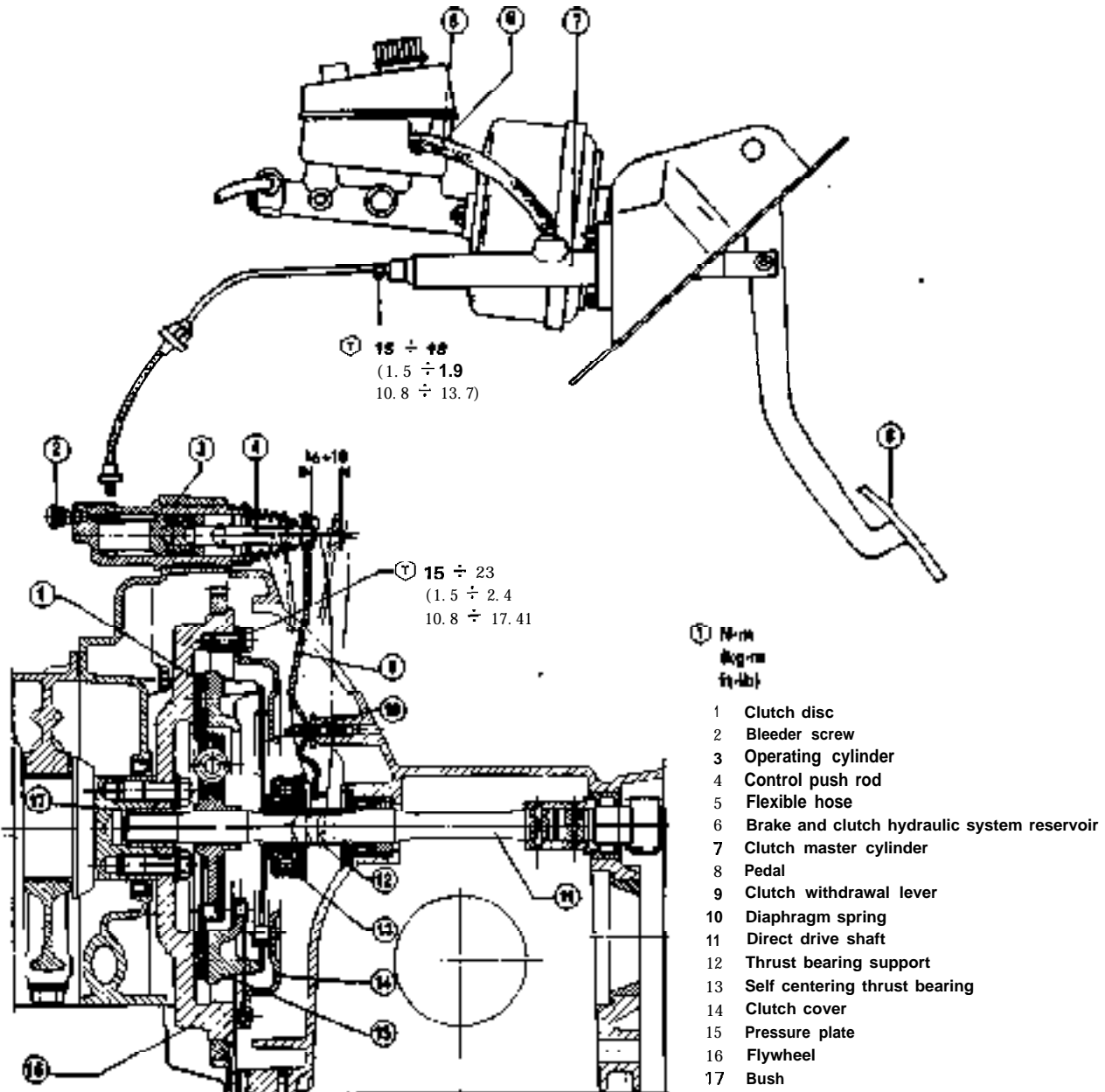

HYDRAULIC CONTROL UNIT

CLUTCH PEDAL

REMOVAL

1. Operating from the interior compartment, remove stopper ring (4), and remove pin (2) disconnecting pedal (3) from master cylinder control fork (1) and return spring.

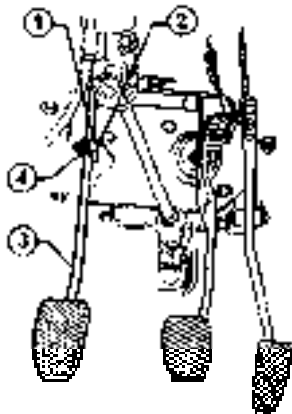

- 1 Fork
- 2 Pin
- 3 Pedal
- 4 Stopper ring

2. Operating from the engine room, remove pedal pin stopper spring (1) and relevant washer. Unscrew screw (3) securing the bracket (2) for sheath stopper of accelerator control cable, in order to be able to withdraw pedal pin enough to recuperate the clutch pedal from the interior compartment.

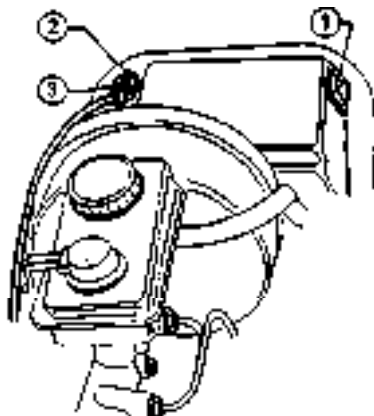

- 1 Stopper spring
- 2 Bracket
- 3 Screw

3. Remove the two plastic bushes from pedal.

CHECKS AND INSPECTIONS

1. Inspect pedal and pedal pad for deformation or damage.
2. Inspect bushes of clutch pedal, pin and spacer for excessive wear or seizing.
3. Inspect return spring for fatigue or damage.

INSTALLATION

Install clutch pedal on car in reverse order of removal and apply grease to bushes of clutch pedal and to master cylinder fork connection pin (AGIP F1 Grease 15).

CLUTCH MASTER CYLINDER

REMOVAL

1. Remove filler plug (1) on reservoir (7), relevant gasket and filter then, with a syringe, drain enough fluid to make level fall below connection to master cylinder (4).
2. Disconnect supply flexible hose (2) from master cylinder.
3. Loosen connection and disconnect rigid pipe (6) from master cylinder.
4. Operating from inside the car, remove stopper ring, remove pin and disconnect cylinder control fork from pedal (see: Clutch Pedal - Removal).
5. Unscrew screws (3) fixing master cylinder to pedal assy and then remove master cylinder.

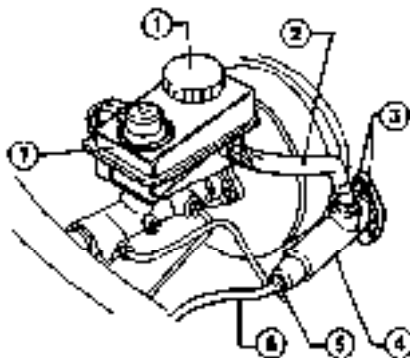

- 1 Plug
- 2 Flexible pipe
- 3 Screws
- 4 Master cylinder
- 5 Connection
- 6 Rigid pipe
- 7 Reservoir

DISASSEMBLY

1. Remove boot (6), remove stopper ring (2), then remove push rod with fork (7), gaskets (5) and (3), piston (4), washer (8) and spring (9).
2. Remove connection (11) and gasket (10).

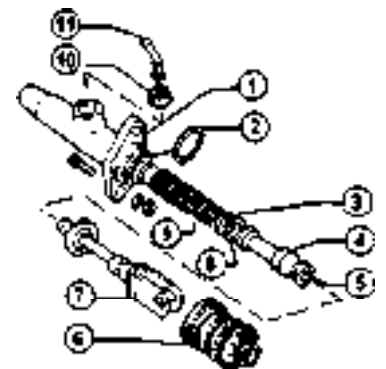

- 1 Master cylinder
- 2 Stopper ring
- 3 Gasket
- 4 Piston
- 5 Gasket
- 6 Boot
- 7 Fork
- 8 Washer
- 9 Spring
- 10 Gasket
- 11 Connection

CHECKS AND INSPECTIONS

CAUTION:

To clean or wash all parts of master cylinder, recommended clean brake fluid must be used. Never use mineral oils or gasoline and kerosene to avoid damaging rubber parts.

1. Check cylinder bore and piston for score or rust and if found replace.
2. Check cylinder bore and piston for wear. If the clearance between cylinder bore and piston exceeds specified value, replace piston assembly or master cylinder assembly.
3. Check condition of boot and replace it if damaged.
4. Check all recesses, openings and internal passages to ensure that they are clean and free from foreign matter.

CLUTCH

ASSEMBLY

1. Lubricate sliding part surfaces.
2. Install piston assembly to cylinder body.
3. Make sure that master cylinder operates normally.
4. Make sure that piston can move maximum stroke smoothly.

INSTALLATION

1. Install clutch master cylinder in reverse order of disassembly.
2. Top up oil to correct level in reservoir.
3. Bleed air out of hydraulic system (Refer to: Hydraulic System Bleeding).

T : Tightening torque
Clutch hydraulic piping connections
15 ÷ 18 N·m
(1.5 ÷ 1.9 kg·m
10.8 ÷ 13.7 ft·lb)

CLUTCH OPERATING CYLINDER

REMOVAL

1. Remove operating cylinder control hose, then remove clutch operating cylinder lock ring ① from its seat on engine back cover ③.
2. Remove operating cylinder.

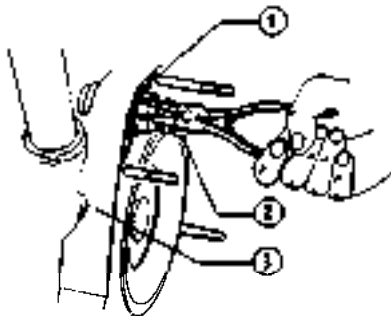

- 1 Lock ring
- 2 Clutch operating cylinder
- 3 Back cover

DISASSEMBLY

1. Remove push rod ① with boot ②, piston ⑨ and piston spring ④ from operating cylinder ⑥.
2. Remove push rod from boot.
3. Remove bleeder screw ⑦.

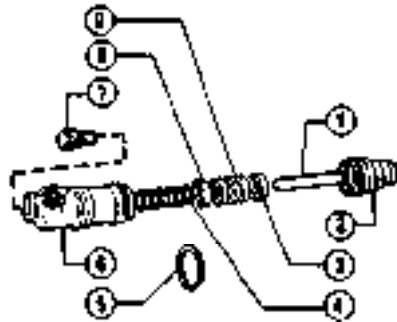

- | | |
|------------|-----------------|
| 1 Push rod | 6 Cylinder body |
| 2 Boot | 7 Bleeder screw |
| 3 Gasket | 8 Gasket |
| 4 Spring | 9 Piston |
| 5 Ring | |

CHECKS AND INSPECTIONS

Visually inspect all disassembled parts and replace parts which are worn or damaged.

CAUTION:

To clean or wash all parts of operating cylinder, recommended clean brake fluid must be used. Never use mineral oils or gasoline and kerosene. It will ruin the rubber parts of the hydraulic system.

1. Check cylinder bore and piston for score or rust.
2. Check cylinder wear, spring efficiency and integrity of seal rings.
3. Check whether bleeder hole is clean.

ASSEMBLY

Assemble clutch operating cylinder in reverse order of disassembly.

INSTALLATION

Assemble clutch operating cylinder in its seat on engine back cover together with retainer ring.

HYDRAULIC SYSTEM PIPING

CHECKS AND INSPECTIONS

Visually inspect clutch lines for evidence of its integrity. Replace damaged parts. If leakage occurs at joints due to loosening, retighten and if necessary replace damaged parts.

DISASSEMBLY

1. Remove filler plug on supply reservoir, together with gasket and filter, and by means of a syringe drain enough fluid to make level fall below connection to master cylinder.
2. Remove flexible hose connecting reservoir and clutch master cylinder and remove pipe.
3. Loosen the rigid and flexible pipes connections, connecting master cylinder and clutch operating cylinder and remove pipes.

INSTALLATION

1. Install clutch line in the reverse order of disassembly.
2. Top up oil in reservoir to correct level.
3. Bleed air out of hydraulic system. (Refer to: Hydraulic System Bleeding).

HYDRAULIC SYSTEM BLEEDING

The clutch and brake hydraulic system must be bled whenever hydraulic system has been disconnected or air has entered it.

Refer to figure on page 12-2 (see: Description) and observe the following procedure.

CAUTION:

- a. Do not re-use brake fluid drained during bleeding operation.
- b. Exercise care to prevent splashing of brake fluid on painted areas as it will damage the paint.
- c. During bleeding operation fluid level in reservoir must be kept above min. mark.

1. Remove clutch and brake hydraulic system reservoir plug and top up with recommended brake fluid (ATE "S" or AGIP F1 Brake Fluid Super HD corresponding to Alfa Romeo Part No. 3681.69905).
2. Remove bleeder screw protection boot ② on Operating cylinder ③; install a hose on same

CLUTCH

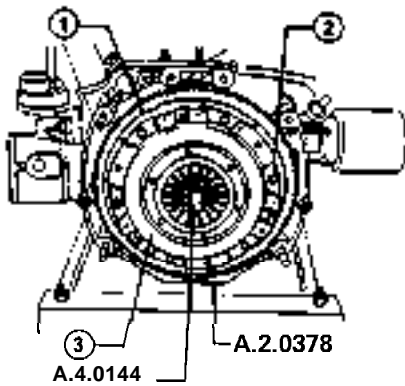

- 1 Flywheel 3 Clutch cover
2 Cover fixing screws

6. Remove cover (2) and clutch disc (1).

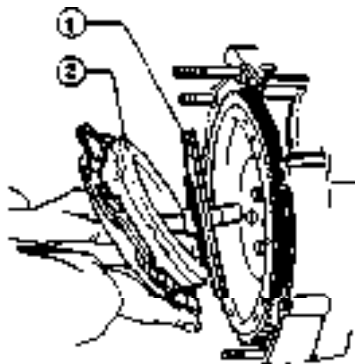

- 1 Clutch disc 2 Clutch cover

CHECKS AND INSPECTIONS

Wash all disassembled parts except clutch with suitable cleaning solvent to remove dirt and grease before making inspection and adjustment.

Clutch cover

Check pressure plate working surface (2) for overheating marks, uneven wear, scoring and material removal.

Replace clutch cover if necessary.



- 1 Clutch cover
2 Pressure plate working surface
3 Diaphragm spring

Flywheel

Check flywheel friction surface (3) for overheating, uneven wear, scoring, or removal of material. If necessary, disassemble flywheel and grind both working surface and clutch cover support plane.

Grinding limit value on planes
0.2 mm (0.01 in)

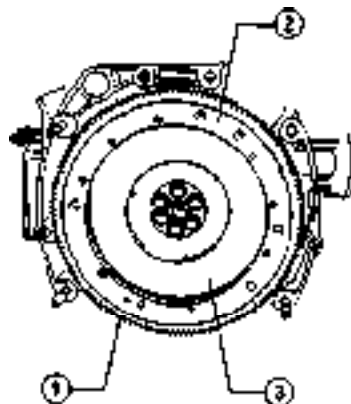

- 1 Engine flywheel
2 Pressure plate support plane
3 Working surface

Clutch disc

Inspect clutch disc for burn or oily facings, loose rivets and broken torsional springs.

1. In case of clutch abnormalities due to oil leakage at crankshaft or direct drive shaft oil seal, replace both clutch disc and seals.

2. Check with a sliding gauge (1) for even wear of both facings and whether clutch disc thickness is not near to specified limit. Replace disc if necessary.

Wear limit for disc thickness
6.5 mm (0.26 in)

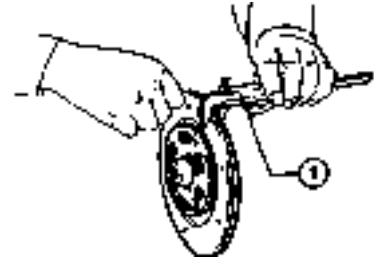

- 1 Sliding gauge

3. Check fit of clutch disc hub (3) on direct drive shaft (2) for smooth sliding or excessive backlash. If necessary replace clutch disc.

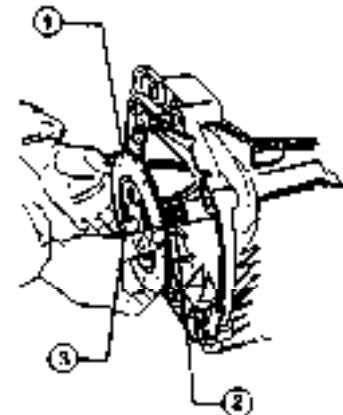

- 1 Clutch disc 3 Clutch disc hub
2 Direct drive shaft

INSTALLATION

1. If the two oil seals on crankshaft and on direct drive shaft have been removed when clutch unit was disassembled, install two new oil seals (Refer to: Group 01 Engine Assembly - Crankshaft and Group 13 5-Speed Manual Gearbox Shafts and Gears).

2. Install flywheel if removed in disassembling clutch unit (Refer to: Group 01 - Engine Assembly). Be sure to keep clutch disc, flywheel and pressure plate facings clean and dry.

3. Set clutch disc and clutch cover on flywheel.

SERVICE DATA AND SPECIFICATIONS

GENERAL SPECIFICATIONS

FLUIDS AND LUBRICANTS

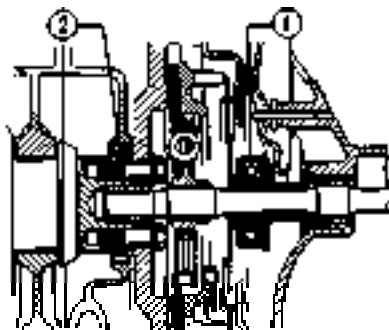

1 Thrust bearing 2 Bush

Application	Type	Denomination	Qty
Thrust bearing working seat ①	GREASE	- AGIPF1 Grease 33 FD Std. N . 367 I-69833134 - IP Autogrease FD Std. N . 367 I-69833134 - ISECO Molykote BR2 Std. N. 3671-69841	- - -
End crankshaft bush ②	GREASE	ISECO Molykote Paste G Std. N. 3671-69840	-
Clutch pedal-cylinder control fork connection pin Clutch pedal hub	GREASE	AGIPF1 Grease 15 Std. N. 3671-69810	-
Clutch hydraulic system supply	FLUID	- ATE "S" - Std. N. 3681-69905 - AGIPF1 Brake Fluid Super HD Std. N. 3681-69905 - IP Auto Fluid FR Std. N. 3681-69905	

INSPECTIONS AND ADJUSTMENTS

FLYWHEEL AND CLUTCH COVER

Grinding limit values on working surfaces 0.2 mm (0.01 in)

CLUTCH DISC

Disc thickness at wear limit 6.5 mm (0.26 in)

COMPLETE CAR

Condition	Probable cause	Corrective action
<p>Spark is good:</p> <ol style="list-style-type: none"> a. Check spark plug b. Check ignition timing c. Check fuel system d. Check cylinder compression 		
<p>Spark is not good:</p>		
<p>Ignition system is out of order</p>	<ul style="list-style-type: none"> • Low or no current in primary circuit • Rotor arm current leakage • Faulty spark plugs • Improper ignition timing • Faulty ignition coil • Cut-off in high voltage cable • Loose connection or cut-off in primary circuit 	<p>Check primary circuit for loose or disconnected terminals</p> <p>Verify that the electronic ignition unit is properly functioning</p> <p>Clean or replace</p> <p>Clean, adjust electrode gap or replace</p> <p>Adjust</p> <p>Replace</p> <p>Replace</p> <p>Repair or replace</p>
<p>Fuel system is out of order</p>	<ul style="list-style-type: none"> • Lack of fuel • Dirty fuel filter • Dirty or clogged fuel pipes • Faulty fuel pump • Faulty carburetor choke • Incorrect float level adjustment • Improper idling • Dirty or clogged carburetor jets • Clogged fuel tank breather pipe 	<p>Refuel</p> <p>Clean</p> <p>Clean</p> <p>Replace</p> <p>Check and adjust</p> <p>Adjust</p> <p>Adjust</p> <p>Disassemble and clean</p> <p>Repair and clean</p>
<p>Low compression</p>	<ul style="list-style-type: none"> • Incorrect spark plug tightening • Incorrect valve clearance • Compression leaks from valve seats • Seized valve stem 	<p>Tighten to normal</p> <p>Adjust</p> <p>Remove cylinder head and lap valves</p> <p>Replace valve and valve guide</p>

COMPLETE CAR

Condition	Probable cause	Corrective action
High engine idling	<ul style="list-style-type: none"> • Stiff accelerator cable and linkage • Incorrect idle adjustment • Malfunctioning throttle valve 	<p>Check</p> <p>Adjust</p> <p>Check</p>
ENGINE POWER NOT UP TO NORMAL		
Low compression	Previously mentioned	Previously mentioned
Ignition system out of order	<ul style="list-style-type: none"> • Incorrect ignition timing • Dirty or worn spark plugs • Incorrect advance 	<p>Adjust</p> <p>Clean or replace</p> <p>Adjust</p>
Fuel system out of order	Previously mentioned	
Other	<ul style="list-style-type: none"> • Faulty fuel pump • Clogged fuel pipes 	<p>Replace</p> <p>Clean</p>
Air intake system out of order	<ul style="list-style-type: none"> • Clogged air cleaner • Air sucking around manifold gasket or carburetor gasket 	<p>Replace cartridge</p> <p>Replace gasket</p>
Overheating	<ul style="list-style-type: none"> • Insufficient coolant • Broken water pump drive belt • Faulty thermostat • Faulty water pump • Clogged or leaky radiator • Faulty electric fan • Faulty thermal switch • Air in cooling system • Clogged jets (lean mixture) • Incorrect ignition timing 	<p>Replenish</p> <p>Replace</p> <p>Replace</p> <p>Replace</p> <p>Clean, repair or replace</p> <p>Replace</p> <p>Replace</p> <p>Restore proper cooling system tightness</p> <p>Overhaul carburetor</p> <p>Adjust</p>
Overcooling	<ul style="list-style-type: none"> • Faulty thermostat • Faulty thermal switch 	<p>Replace</p> <p>Replace</p>

COMPLETE CAR

Condition	Probable cause	Corrective action
Other	<ul style="list-style-type: none"> <li style="text-align: center;">Petrol used has low octane rating <li style="text-align: center;">Dragging brakes <li style="text-align: center;">Slipping clutch 	<p>Replace with petrol having specified octane rating</p> <p>Adjust</p> <p>Adjust or replace</p>
NOISY ENGINE (while driving) Engine knocking	<ul style="list-style-type: none"> Overloaded engine Knocking due to carbon deposit Knocking due to incorrect ignition timing Knocking due to improper petrol Preignition (due to wrong type spark plugs) 	<p>Use proper gear in driving</p> <p>Disassemble cylinder head and remove carbon deposit</p> <p>Adjust ignition timing</p> <p>Use petrol having specified octane rating</p> <p>Replace with specified type spark plugs</p>
Mechanical knocking Crankshaft bearings knocking	<ul style="list-style-type: none"> Worn crankshaft bearings <p>This strong dull noise increases as engine is accelerated</p>	<p>Replace bearings and either grind or replace crankshaft. Check lubrication system</p>
Connecting rod bearings knocking	<ul style="list-style-type: none"> Worn connecting rod bearings <p>This is a slightly higher-pitched noise than the one caused by knocking of crankshaft bearings and it also increases as engine is accelerated</p>	<p>Same as for above crankshaft bearings</p>
Noisy pistons	<ul style="list-style-type: none"> Pistons and/or cylinder liners are worn <p>This is a diffused metallic noise which increases as rpm increase and decreases when engine is warm</p>	<p>Overhaul the engine</p>
Noisy water pump	<ul style="list-style-type: none"> Play in rotor 	<p>Replace water pump</p>
Other	<ul style="list-style-type: none"> Improper adjustment of valve clearance Excessive crankshaft end play 	<p>Adjust</p> <p>Replace crankshaft axial bearings</p>

COMPLETE CAR

Condition	Probable cause	Corrective action
ABNORMAL COMBUSTION (backfire, self-ignition, detonations) Incorrect ignition	<ul style="list-style-type: none"> • Incorrect ignition timing • Wrong type spark plugs 	Adjust timing Replace with recommended type plugs
Fuel system out of order	Previously mentioned	Previously mentioned
Faulty cylinder heads	<ul style="list-style-type: none"> • Incorrect valve clearance • Excessive carbon deposit in combustion chambers • Damaged valve springs (backfire detonations) 	Adjust Disassemble cylinder heads and remove carbon deposit Replace
EXCESSIVE OIL CONSUMPTION Oil leaks	<ul style="list-style-type: none"> • Loose oil drain plug • Loose oil pan screws • Worn or damaged oil pan gasket • Worn or damaged cylinder block and cylinder head gaskets and oil seal rings • Loose oil filter • Loose oil pressure switch • Dipstick does not fit tightly 	Tighten it Tighten or replace Replace gasket Replace gaskets and oil seal rings Tighten or replace, if necessary Tighten Replace dipstick
Excessive oil consumption	<ul style="list-style-type: none"> • Worn cylinders and pistons • Improperly assembled piston rings • Worn piston rings • Worn piston rings and piston ring seats • Worn valve guides and grommets • Worn valve stems 	Grind cylinders and replace pistons Assemble properly Replace piston rings or, if required, grind cylinders and replace pistons Replace pistons and rings Replace valve guides and grommets Replace valves
Other	<ul style="list-style-type: none"> • Improper oil grade • Engine overheats 	Replace with specified oil type Previously mentioned

COMPLETE CAR

Condition	Probable cause	Corrective action
EXCESSIVE FUEL CONSUMPTION		
Engine power not up to normal	Previously mentioned	Previously mentioned
Other	<ul style="list-style-type: none"> • Idling too high • Improper accelerator recovery • Fuel leaks • Clogged air cleaner • Improperly adjusted carburetor • Worn or damaged carburetor gaskets 	Adjust idling Adjust Repair or tighten fuel line unions Replace cartridge Adjust Replace gaskets
OTHER PROBLEMS		
Reduced oil pressure	<ul style="list-style-type: none"> • Improper oil grade • Oil is missing • Overheating • Worn oil pump control valve • Worn oil pump • Excessive play of sliding parts • Clogged oil filter • Faulty oil pressure switch 	Replace with specified oil type Replenish with specified oil type Previously mentioned Disassemble oil pump, repair or replace it Repair or replace Disassemble and replace worn parts Replace cartridge Replace
Excessive wear of sliding parts	<ul style="list-style-type: none"> • Insufficient oil pressure • Improper oil grade or contaminated oil • Faulty air cleaner • Overheating or overcooling 	Previously mentioned Replace with specified type oil and replace cartridge Replace cartridge Previously mentioned
Seizing of sliding parts	<ul style="list-style-type: none"> • Insufficient oil pressure • Insufficient clearances • Overheating 	Previously mentioned Adjust to specified values Previously mentioned

CHASSIS AND BODY MAINTENANCE

CHECKING FUEL AND EXHAUST SYSTEM

1. Check fuel and exhaust systems, especially at connections, making sure there are no leaks.
2. Check condition of all fuel and exhaust pipes replacing same if required.
3. Tighten all loose connections.

CLUTCH

CHECKING CLUTCH SYSTEM

Check clutch pump ① and clutch control cylinder ② making sure there are not oil leaks. If required, tighten unions according to specified torques or either overhaul or replace faulty parts (Refer to: Group 12 - Tightening Torques).

Make sure that clutch pump and control cylinder boots are not in any way damaged.

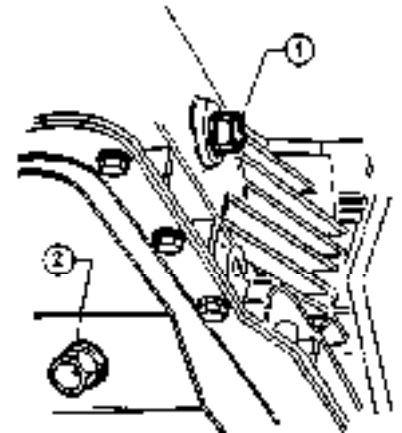

1 Oil supply plug 2 Oil drain plug

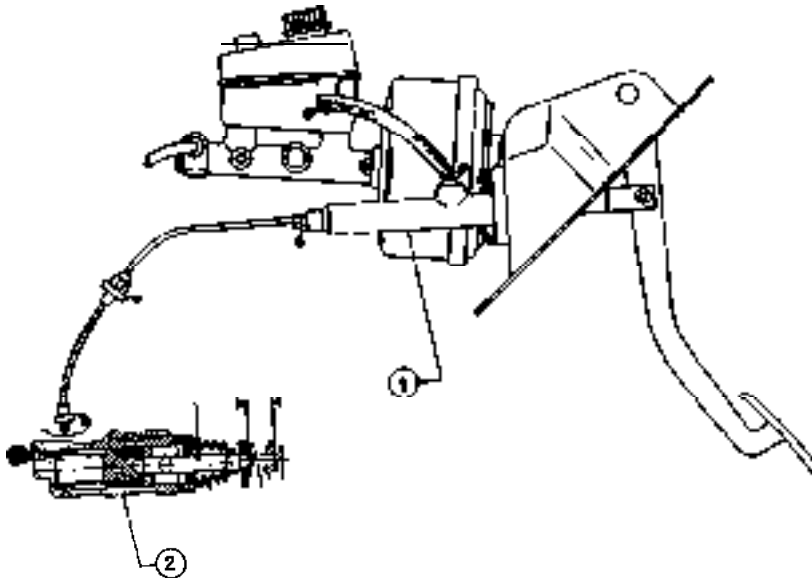

1 Clutch pump
2 Clutch control cylinder

ASSEMBLY DRIVE SHAFT

CHECKING DRIVE SHAFT ASSEMBLY

Visually check drive shaft assembly for wear or deformation of its various components, making sure protecting boots are not in any way damaged or show grease leakage. If necessary, replace damaged or worn parts.

GEARBOX-DIFFERENTIAL

CHECKING GEARBOX-DIFFERENTIAL OIL LEVEL

Check oil level making sure it reaches filler lower edge; clean relevant cap and tighten it.

REPLACING GEARBOX-DIFFERENTIAL OIL

1. While engine is warm, remove oil pan drain ② and supply ① plugs.

2. Let oil drain completely (wait at least 15 minutes); clean drain plug ② and tighten it.
3. Refill oil pan through supply hole ① with specified oil type and quantity. Refer to "LUBRICANTS" chart for recommended oil type.

Gearbox-Differential casing oil capacity
2.3 ÷ 2.4 kg (5.07 ÷ 5.29 lb)

FRONT AXLE AND FRONT SUSPENSION

CHECKING FRONT AXLE AND SUSPENSION

1. Block rear wheels with chocks and raise front of vehicle fitting jack to proper lifting points (Refer to: "Lifting Points and Towing").

2. Check front suspension parts for wear or damage.

Also check all bolts for proper tightening; refer to: Group 21 - Tightening Torques - for relevant tightening torques.

Replace worn parts according to relevant procedures described in Group 21 Front Suspension.

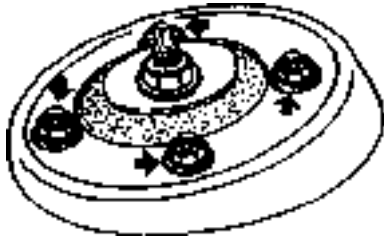

ADJUSTING WHEEL BEARING PRELOAD

After replacement or disassembly of bearings, carry out adjustment operating as follows.

For wheel bearing replacement refer to Group 25.

1. Tighten wheel bearing lock-nut according to specified torque and at the same time turn hub $4 \div 5$ times in both directions to allow bearings to settle.

T: Tightening torque
 Wheel bearing lock-nut
 $25 \div 29 \text{ N}\cdot\text{m}$
 $(2.5 \div 3 \text{ kg}\cdot\text{m})$
 $18.08 \div 21.69 \text{ ft}\cdot\text{lb}$

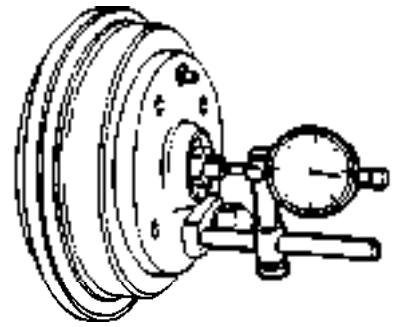

5. Caulk nut taking care to avoid rotation in order not to alter clearance play.

Apply specified grease quantity to bearings in the suspension.

CHECKING SUSPENSION HEIGHTS

Be sure to perform following preliminary operations:

- a. Set up vehicle with all refill liquids at max. level and with spare wheel.
- b. Check tire pressure; refer to "Wheels and Tires" for specified values.
- c. Place car on lift.
- d. Load weights on vehicle as shown in below figure.
- e. Move vehicle up and down on suspensions a few times.

Static load equivalent to three passengers plus luggage

Passenger equivalent to
 $A + B = 490 + 245 = 735 \text{ N}$
 $(50 + 25 = 75 \text{ kg})$
 $(110 + 55 = 165 \text{ lb})$

Luggage C = 490 N (50 kg; 110 lb)

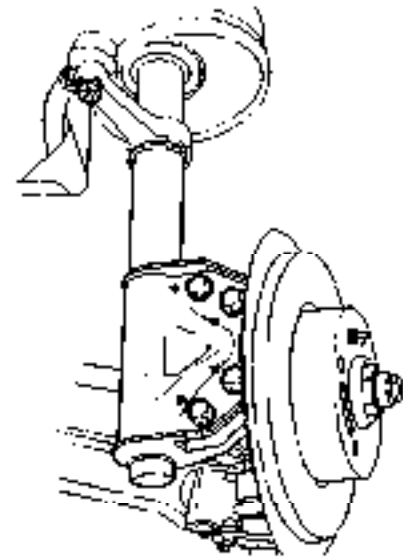

3. Check shock absorbers for oil leaks or damage.
4. Remove wheels.
5. Check brake pads for wear (Refer to: Group 22 - Front Disc Brake).

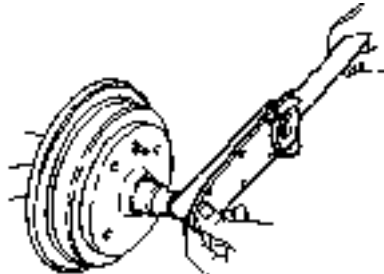

2. Partially unscrew lock-nut and hit the hub with a mallet to ensure outer bearing settling against washer and nut.
3. t-land tighten the nut (moderately, so as to obtain a less than $1 \text{ N}\cdot\text{m}$; $0.1 \text{ kg}\cdot\text{m}$; $0.72 \text{ ft}\cdot\text{lb}\cdot\text{torque}$).
4. Check and make sure axial play is within specified value.

Bearing axial play
 $0 \div 0.05 \text{ mm } (0 \div 0.002 \text{ in})$

REAR AXLE AND REAR SUSPENSION

CHECKING REAR AXLE AND SUSPENSION PARTS

1. Check rear axle and suspension for loose, worn or damaged parts.
2. With vehicle in nominal driving condition, i.e. with static load (Refer to: Checking Suspension Heights), tighten loose bolts according to specified tightening torque. Refer to: Group 25 Service Data and Specifications for relevant tightening torques.
3. Replace worn parts according to the relevant procedures described in Group 25.

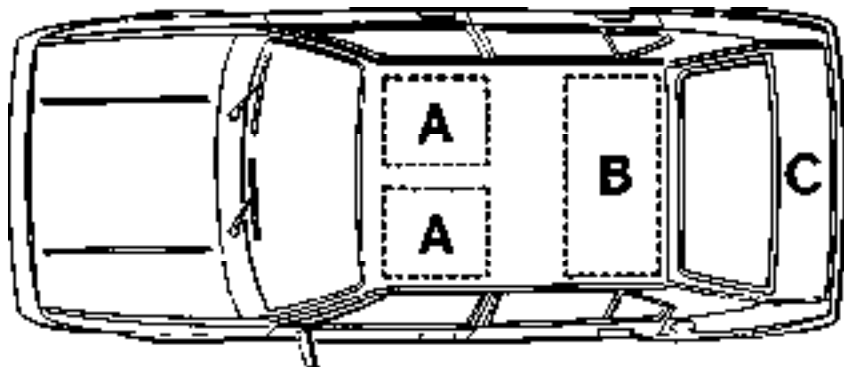

COMPLETE CAR

FRONT SUSPENSION HEIGHT

Check front wheel alignment picking up specified "A" dimension which is obtained by drawing two lines parallel to floor plane respectively passing through below defined points 1 and 2.

Point 1:
it is the intersection between the

plane passing on the base of the nut connecting hub support to control arm, and the straight line tangent to the hub support.

Point 2:
axis of the bolt securing control arm to chassis.

Front wheel alignment dimension
 $A = 12 \pm 7 \text{ mm}$
 $(0.47 \pm 0.28 \text{ in})$

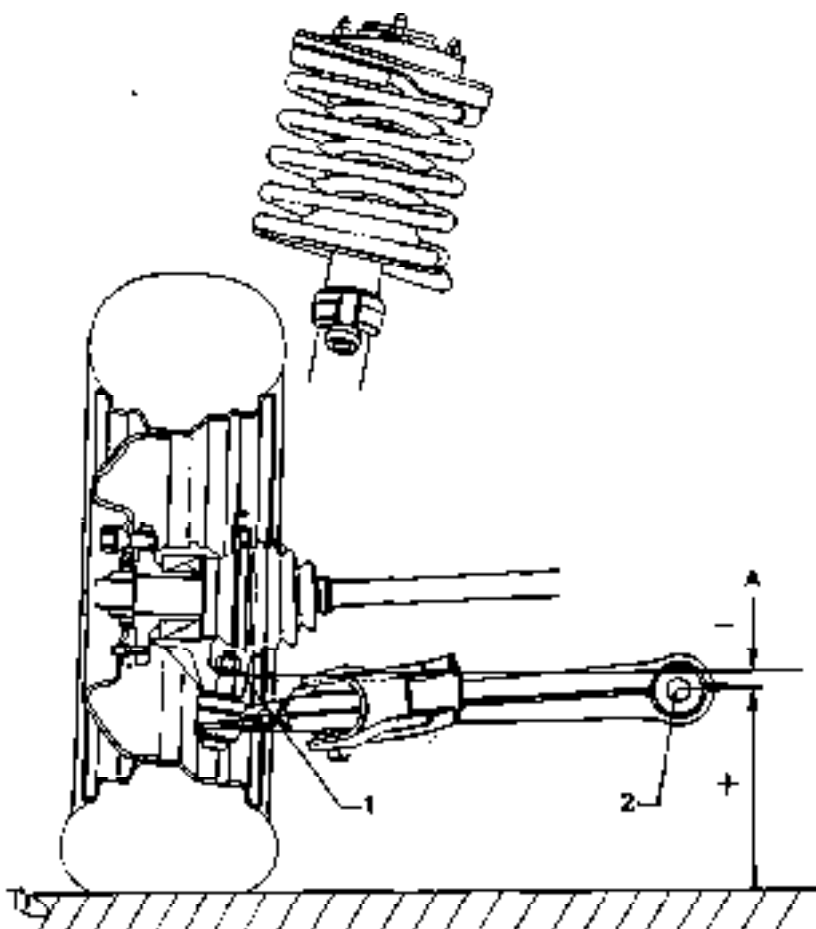

"A" dimension must be picked up for both front right and front left suspensions.

DIMENSION MEASUREMENT

1. Carry out measurement of dimension relevant to step 1. making use of the following tools and

setting the graded movable stem of check tool to the complete backward position (see following figure).

- (1) Rule (3) A-4.0146.
- (2) Tool for suspension height check @ A.4.0149.
- (3) Probe (1) A-4.0150.

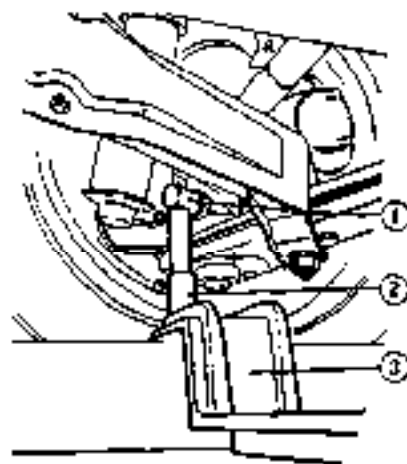

- 1 Probe
- 2 Height check tool
- 3 Rule

2. Carry out measurement of dimension relevant to step 2. making use of the following tools and moving only graded stem of check tool.

- (1) Rule (3) A.4.0146.
- (2) Tool for suspension height check @ A.4.0149.
- (3) Magnetic adapter (1) A.4.0153.

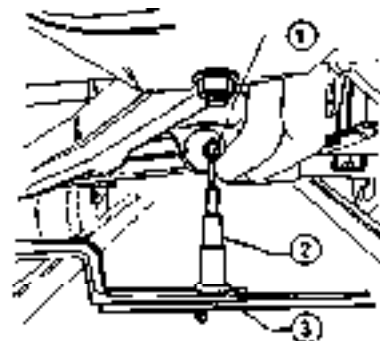

- 1 Magnetic adapter
- 2 Tool for suspension height check
- 3 Rule

3. Directly read on graded scale (located on movable stem of check tool) the "A" height dimension value.

REAR SUSPENSION HEIGHT

(1) Check rear wheel alignment by measuring specified "B" dimension which is the distance between the two lines parallel to floor plane and passing through below defined points 1 and 2.

Point 1:

Axis of bolt ① securing front rod to wheel support.

Point 2:

Axis of bolt ② securing front rod to body.

Car rear suspension height dimension
 $B = 23 \pm 7 \text{ mm} (0.90 \pm 0.27 \text{ in})$

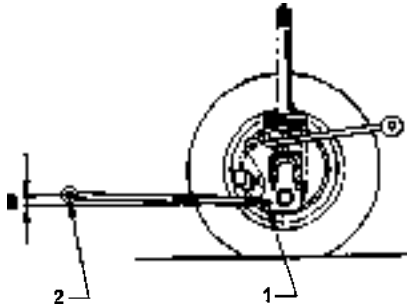

Measurement of "B" dimension must be carried out both for right tie rod and for left tie rod of rear suspension.

DIMENSION MEASUREMENT

1. Carry out measurement of dimension relevant to point 1 and 2 making use of the following tools.

- (1) Rule ③ A.4.0146.
- (2) Tool for suspension heights check ② A.4.0149.
- (3) Magnetic adapter ① A.4.0206.

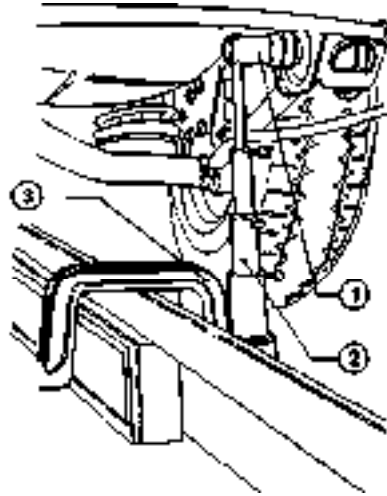
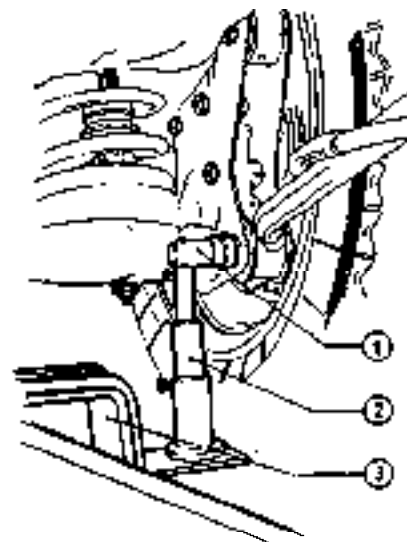

- 1 Magnetic adapter 3 Rule
- 2 Check tool

Proceed as follows to carry out dimension measurement relevant to point 1; set graded movable stem of check tool to the completely backward position, then measure dimension relevant to point 2. by moving only graded stem of tool.

2. Directly read on graded scale (located on movable stem of check tool) the value of "B" height dimension.

In case the read values differ from the prescribed ones, replace springs.

WHEEL ALIGNMENT

CHECKING FRONT WHEEL ALIGNMENT

Be sure to perform following preliminary operations prior to checking and, if necessary, adjust front wheel angles.

- a. Check tire pressure; refer to Group 28 - Checking Tire Conditions.
- b. Set up vehicle with static load.
- c. Pick up front wheel alignment & "B" dimension as well as rear wheel alignment "B" dimension (Refer to: Checking Suspension Heights).

1. Toe-out

On aligned wheels, verify that steering wheel racks are properly centred. If necessary, withdraw

steering wheel and centre racks. (1) Use suitable equipment and measure toe-out making sure it is within specified value.

Toe-out
 $H - M = +4 \pm 1 \text{ mm}$
 $(+0.157 \pm 0.04 \text{ in})$

Front toe-out angle
 $a = 10'$

Wheel rim diameter
 $O = 340 \text{ mm} (13 \text{ in})$

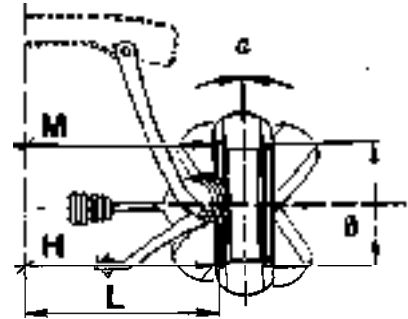

(2) If necessary, adjust toe-out as follows:

- Loosen side rod lock-nut
- By means of tool A-3.0156 disconnect vertical steering lever ball joint (Refer to: Group 21 - Coil Springs and Shock absorbers).
- Suitably turn ball joint still specified toe-out is achieved.

Min. possible toe-out adjustment is 42 mm (0,08 in) on H - M difference (variation corresponds to 1 turn - 1 mm (0,039 in) thread lead - of one ball joint) meaning that semi toe-out value is equal to:

$$L = (1/2 M + 2 \pm 0,5) \text{ mm}$$

$$(1/2 M + 0.08 \pm 0,020 \text{ in})$$

- Orientate joint body ② located on side rod ⑤ so that, after being connected to steering lever ④, the joints upper level ① is parallel to the lever's upper level ③.
- Tighten lock-nut ⑥ and then tighten to specified torque the nuts securing ball joint to steering lever.

- Ⓣ : Tightening torque
 Nut securing side rod ball joint
 onto vertical steering lever
 39 ÷ 48 N·m
 (4 ÷ 4.9 kg·m
 28.92 ÷ 35.43 ft·lb)

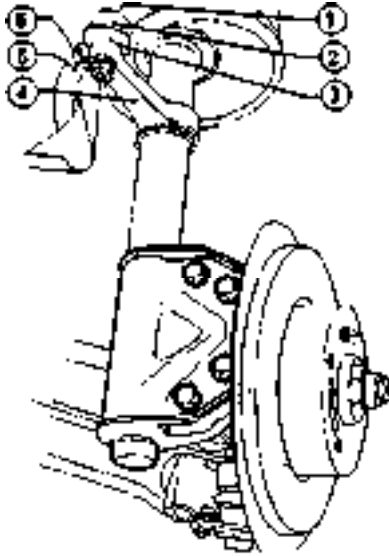

- 1 Joints upper level
- 2 Joint body
- 3 Steering lever's upper level
- 4 Steering lever
- 5 Side rod
- 6 Lock nut

(3) Recheck toe-out value.

2. Camber angle
 $\beta = 2^{\circ}15' \pm 30'$

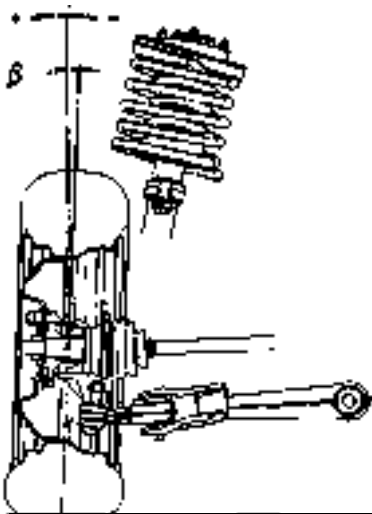

3. Caster angle
 $\gamma = 1^{\circ} \pm 30'$

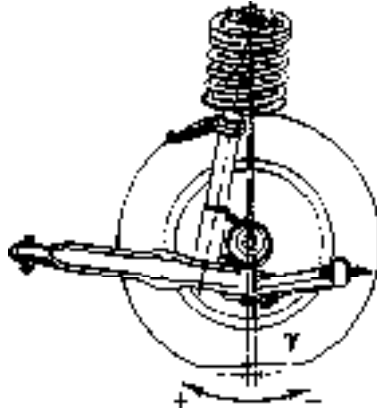

Camber and caster angles cannot be adjusted.

4. Max steering angle
 $\delta = 33^{\circ} 30'$

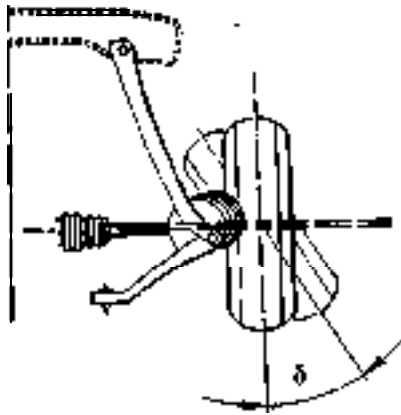

CHECKING REAR- WHEEL ALIGNMENT

Rear angles cannot be adjusted.

- Toe-in angle
 $a = 0^{\circ} \pm 25'$

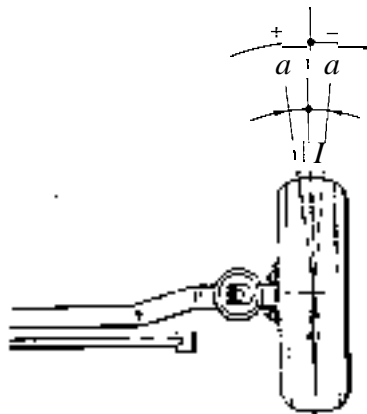

- Camber angle
 $\beta = 0^{\circ} \pm 25'$

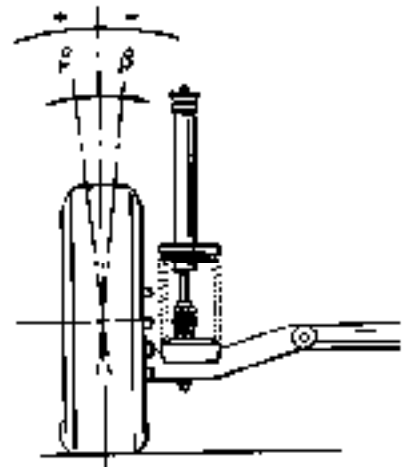

BRAKE SYSTEM

CHECKING BRAKE FLUID LEVEL

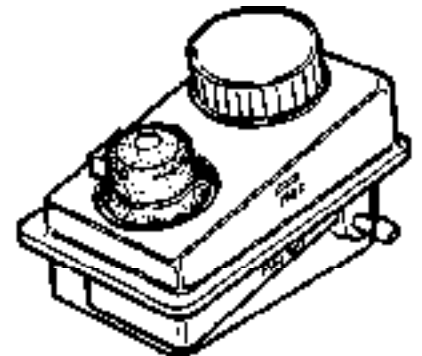

Check and make sure fluid level in reservoir is not more than 1/4 below max. level. If fluid level is extremely low, check brake system for leaks.

CHANGING BRAKE FLUID

1. Connect a hose to wheel bleeders and let brake fluid drain into a suitable container (refer to: Group 22).

CAUTION:

Be extremely careful not to drop any of the brake fluid on painted surfaces since it is highly corrosive.

2. Refill system with new oil and bleed all air from the system (refer to: Group 22 - Brake System Bleeding).

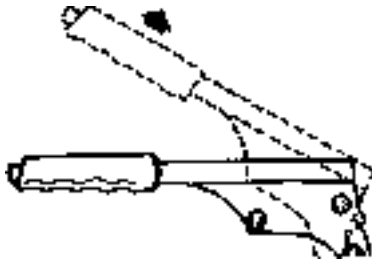

(4) Maneuverability of control lever must result to be easy and smooth running and when control lever is engaged hooking tooth must be into its seat in the scroll gear without difficulty.

3. If required, carry out travel adjustment by operating on nut and lock nut of adjustment fork located under passenger compartment central console.



4. Besides, verify the following:
 (1) With control lever in the rest position also jaws must be at rest.
 (2) When operating control lever, cables must slide freely.
 (3) Indicator lamp must switch on within one click of parking brake control lever and switch off as soon as control lever is at rest position.

STEERING SYSTEM

1. Check steering for sticking or stiffness when turning wheels in both directions,
2. Rotate steering wheel clockwise and anticlockwise checking steering system for excessive play. For relevant adjustment refer to: Group 23 - Checks and Inspections - Rack Box and Guide Tube.
3. Tighten, where required, all steering system connecting points. (Refer to: Group 23 - Tightening torques).
4. Check condition of steering box protecting boots and replace them if necessary.
5. Check steering rod ball and flexible joints; replace them if worn.

BODY

LOCKS AND HINGES

1. Lubricate hinges and locks.
2. Adjust lock striker plates.

CHECKING SEAT BELTS

CAUTION:

- If seat belts have to be washed, do not use chemical detergents or solvents since they could damage the buckles.
- After a serious accident involving belt stress, replace same even if apparently it does not seem to be damaged.

1. Check anchors making sure they are not loose on mountings.
2. Check belts for wear.
3. Check proper working condition of buckles and tongues,
4. Fasten seat belts and check if in case of sudden movement they are promptly locked. Contrarywise, check retractors' locking system.

If condition of any seat belt component is questionable, replace the entire belt assembly involved.

SERVICE DATA AND SPECIFICATIONS

ENGINE MAINTENANCE

TECHNICAL DATA - INSPECTION AND ADJUSTMENT

Engine

		Engines		
		1200	1350	1500
Valve clearance (cold engine)				
Intake	m m (in)	0.35 ÷ 0.40 (0.014 ÷ 0.016)		
Exhaust	m m (in)	0.45 ÷ 0.50 (0.018 ÷ 0.020)		
Alternator-pump belt tension				
Force applied to belt	N (kg, lb)	79 (8 ; 3.63)		
Deflection	mm (in)	15 (0.59)		
Cylinder compression				
Min compression pressure	kPa (bar , p.s.i. , kg/cm ²)	1030 (10.30, 149.39; 10.5)		
Max compression difference between cylinders	kPa (bar, p.s.i. , kg/cm ²)	98 (0.98 ; 14.22; 1)		

COMPLETE CAR

CHASSIS AND BODY MAINTENANCE

TECHNICAL DATA - INSPECTION AND ADJUSTMENT

Axles and suspensions

Vehicle static loading arrangement (1)	N (kg, lb)	$A+B = 490 + 245 = 735$ ($50+25 = 75$) $(110 + 55 = 165)$ $c = 490$ (50);(110)
Front wheel alignment	mm (in)	$A = 12 \pm 7$ (0.47 ± 0.28)
Rear wheel alignment	mm (in)	$B = 23 \pm 7$ (0.90 ± 0.27)
Front wheel toe-out (2)(3)	mm (in)	$M - H = 4 \pm 1$ (0.157 to 0.04)
Front wheel semi toe-out (2)(3)	mm (in)	$L = (1/2 M + 2 \pm 0.5)(1/2 M + 0.08 \pm 0.02)$
Front toe-out angle		$\alpha = 10'$
Wheel rim diameter	mm (in)	$\emptyset = 340$ (13.38)
Rear wheel toe-in		$\alpha = 0^\circ \pm 25'$
Front wheel camber (3)		$\beta = -2^\circ 15' \pm 30'$
Rear wheel camber		$\beta = 0^\circ \pm 25'$
Front wheel caster (3)		$\gamma = 1^\circ \pm 30'$
Max steering angle (3)		$\delta = 33'' 30'$

- (1) Load vehicle, move it up and down on suspensions a few times. Checking operations must be performed with vehicle fully set up for driving.
- (2) When turning a steering side rod joint by 360° , M - H dimension changes by 2 mm (0.079 in).
- (3) These values are referred to a vehicle in nominal driving condition, i.e. with static load

Brake system

Disc brake		
Disc min. thickness	mm (in)	9 (0.354)
Pad min. thickness	mm (in)	7 (0.276)
Drum brake		
Lining min. thickness	mm (in)	0.5 (0.019)
Max drum inner diameter	mm (in)	229.6 (9.04)
Parking brake		
Lever stroke, when applying a pulling force of $\cong 98$ N (10 kg) (22 lb)		2 notches

CLUTCH

TIGHTENING TORQUES

Unit	N·m	kg·m	ft·lb
Clutch cover to engine flywheel unit securing screws	15 ÷ 23	1.5 ÷ 2.4	10.8 ÷ 17.4
Gearbox unit to engine rear cover securing bolts and nuts	39 ÷ 47	4 ÷ 4.9	28.9 ÷ 35.4
Hydraulic system pipe fitting securing nuts	15 ÷ 18	1.5 ÷ 1.9	10.8 ÷ 13.7



TROUBLE' DIAGNOSIS AND CORRECTIONS

Condition	Probable cause	Corrective action
<p>Clutch slip</p> <p>Symptoms:</p> <ul style="list-style-type: none"> – Car will not respond to engine speed during acceleration – Insufficient car speed – Lack of power during uphill driving – Increasing of fuel consumption 	<p>Some trouble symptoms may also be attributable to engine problems. First determine whether engine or clutch is causing the problem.</p> <p>To test for slipping proceed as follows:</p> <ul style="list-style-type: none"> – engage parking brake – disengage clutch and shift gears into 4th – increase engine speed and gradually release clutch pedal; if car does not move and engine does not stop, clutch is slipping <ul style="list-style-type: none"> • Clutch facing excessively worn • Clutch facing wet with oil or grease • Diaphragm spring weak or damaged • Flywheel or pressure plate warped • Impurities in master cylinder, piston does not return to start position 	<p>Replace clutch disc</p> <p>Replace clutch disc (replace engine/gearbox oil seals) if faulty</p> <p>Replace pressure plate</p> <p>Repair per replace flywheel or clutch cover</p> <p>Clean cylinder or replace faulty parts</p>
<p>Clutch does not disengage well</p>	<p>To test for dragging clutch proceed as follows:</p> <ul style="list-style-type: none"> – disengage clutch and shift gears into Reverse – shift gears into Neutral, then gradually increase engine speed – after a short interval, shift gears into Reverse <p>If noise is heard while gears are being shifted, clutch is dragging</p> <ul style="list-style-type: none"> • Clutch disc hub splines or rusted 	<p>Clean or replace clutch disc</p>

CLUTCH

Condition	Probable cause	Corrective action
	<ul style="list-style-type: none"> • Flywheel and/or pressure plate facings worn or warped • Engine supports not efficient 	<p>Repair or replace flywheel and/or clutch cover</p> <p>Inspect and/or replace engine supports</p>

SPECIAL SERVICE TOOLS

Tool number	Tool name	Refer to page
A.2.0378	Tool for locking the flywheel <div style="text-align: right; margin-top: 10px;">  </div>	12-5
A.4.0144	Clutch disc aligning bar <div style="text-align: right; margin-top: 10px;">  </div>	12-5 12-7

GEARBOX

GROUP 13

CONTENTS

5 - SPEED MANUAL GEARBOX.. . . .	13-2	Checks and inspections	13-25
Description	13-5	Assembly	13-25
Rear support	13-5	SERVICE DATA AND	
Rods and forks	13-6	SPECIFICATIONS	13-26
Shafts and gears	13-10	Technical data	13-26
Differential carriers	13-19	General specifications	13-26
Crown gear and pinion	13-22	Inspection and adjustment	13-28
Differential casing	13-22	Tightening torques	13-30
Gearbox - differential casing	13-24	TROUBLE DIAGNOSIS AND .	
GEARBOX OUTER LINKAGE.. . . .	13-25	CORRECTIONS	13-31
Disassembly	13-25	SPECIAL SERVICE TOOLS	13-33



5-SPEED MANUAL GEARBOX

Gearbox-differential unit and rear support

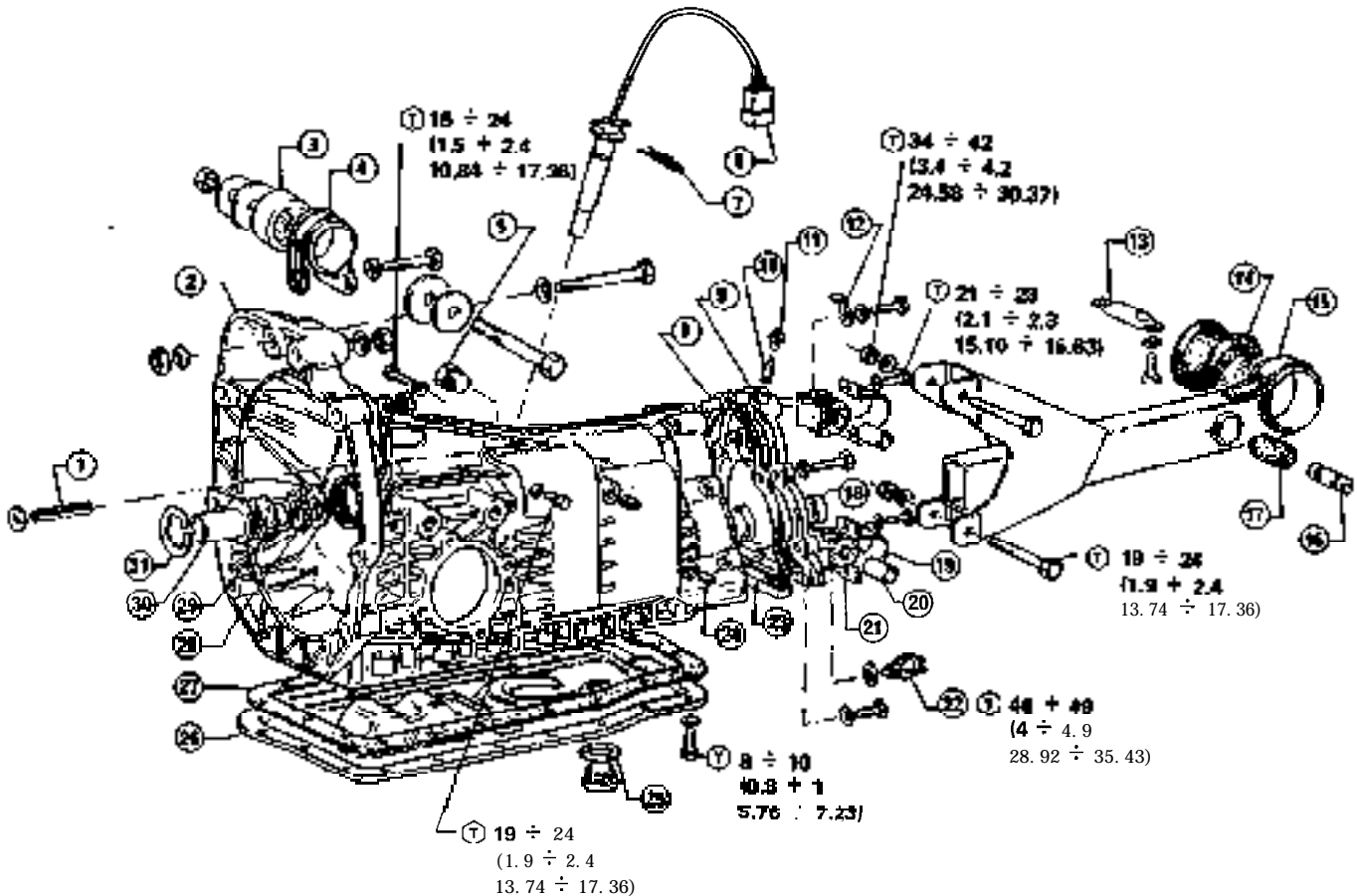

⊕ N·m
(kg·m
ft·lb)

- | | |
|----------------------|------------------------|
| 1 Pin | 17 Flexible bush |
| 2 Gearbox casing | 18 Oil seal ring |
| 3 Bushing | 19 Bracket |
| 4 Central support | 20 Bushing |
| 5 Oil plug | 21 Flexible support |
| 6 Speedometer sensor | 22 Reverse gear switch |
| 7 Spring ring | 23 Gasket |
| 8 Dowel | 24 Plug |
| 9 Rear cover | 25 Drain plug |
| 10 Valve | 26 Oil sump |
| 11 Plug | 27 Gasket |
| 12 Plate | 28 Bushing |
| 13 Pin | 29 Oil seal ring |
| 14 Flexible support | 30 Support |
| 15 Rear support | 31 Lock ring |
| 16 Spacer | |

G EARBOX

Shafts, gears and differential casing

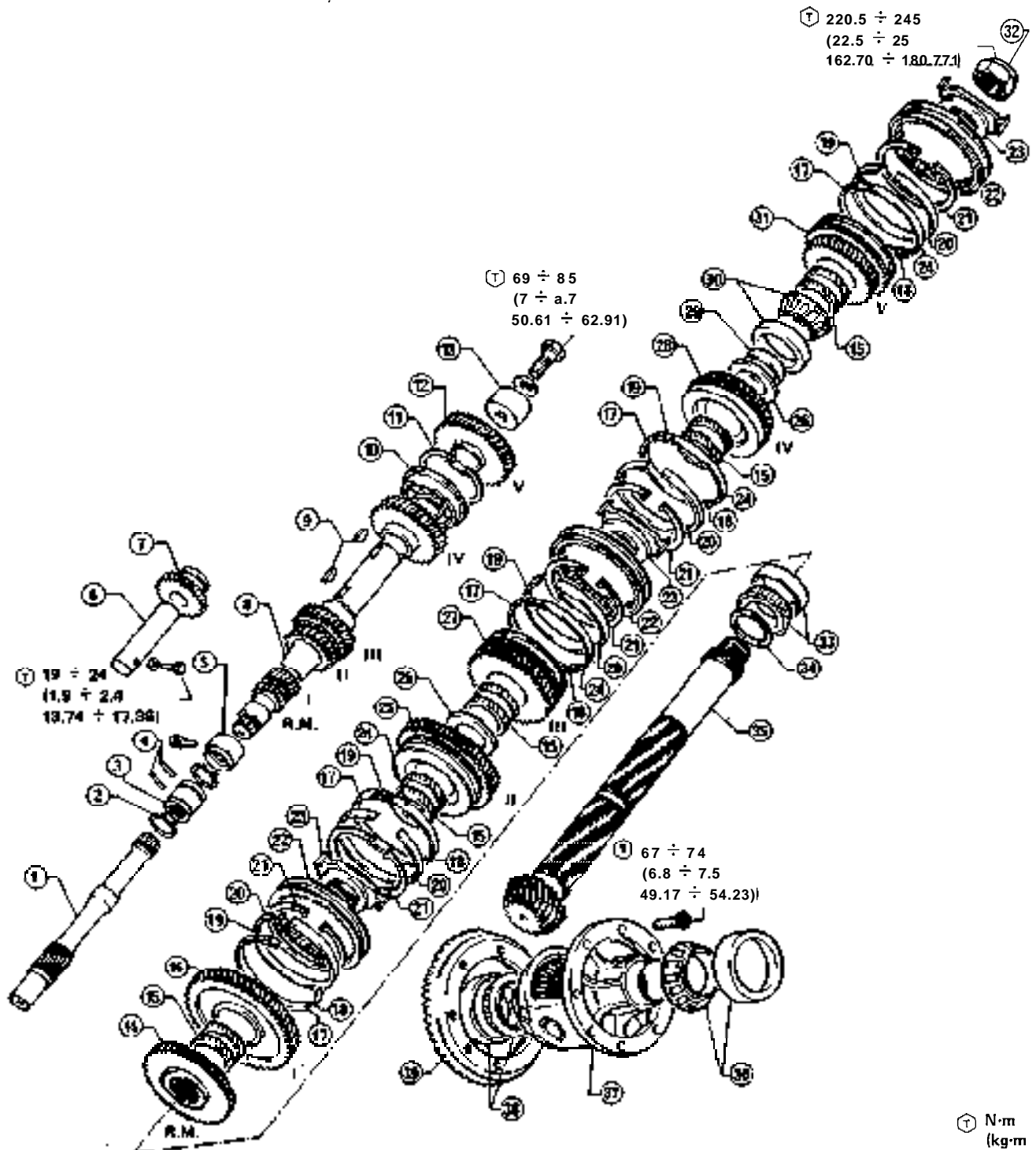

- | | | |
|---------------------------|--------------------------|--------------------------|
| 1 Direct drive shaft | 14 R.G. driven gear | 27 3rd speed driven gear |
| 2 Spring | 15 Bushing | 28 4th speed driven gear |
| 3 Bushing | 16 1st speed driven gear | 29 Shim |
| 4 P i n | 17 Retainer | 30 Bearing |
| 5 Bearing | 18 Guide sector | 31 5th speed driven gear |
| 6 Reverse gear shaft | 19 Locking sector | 32 Nut |
| 7 Reverse gear | 20 Synchronizing ring | 33 Bearing |
| 8 Primary shaft | 21 Lock ring | 34 Shim |
| 9 longue | 22 Sleeve | 35 Pinion |
| 10 Bearing | 23 Hub | 36 Bearing |
| 11 Lock ring | 24 Fietainer | 37 Differential casing |
| 12 5th speed driving gear | 25 2nd speed drive gear | 38 Bearing |
| 13 Oil deflector | 26 Shouldered ring | 39 Crown gear |

⊕ N·m
(kg·m
ft·lb)

GEARBOX

Roda and forks

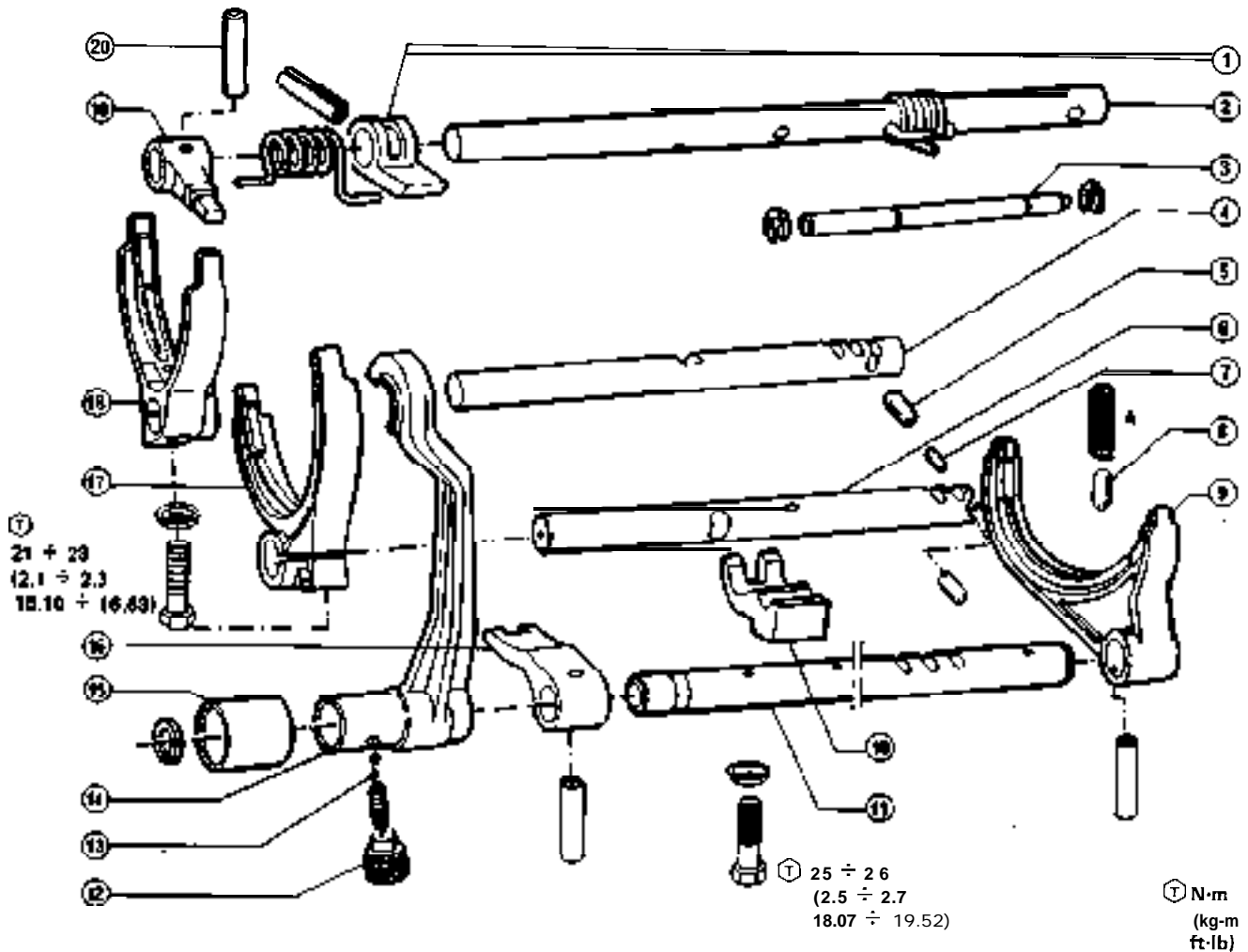

- | | | | |
|----|------------------------|----|----------------------------|
| 1 | Lever | 11 | 5th-speed R.G. rod |
| 2 | Main selector rod | 12 | Plug |
| 3 | Guide pin | 13 | Balls |
| 4 | 3rd-4th speed rod | 14 | R.G. fork |
| 5 | Interlock plunger | 15 | Bushing |
| 6 | 1 sr-2nd speed rod | 16 | 5th-speed - R.G. rod |
| 7 | Interlock plunger | 17 | 1st-2nd speed control fork |
| 8 | Detent ball | 18 | 3rd-4th speed control fork |
| 9 | 5th speed control fork | 19 | Selector lever |
| 10 | 1st-2nd speed lever | 20 | Spring pin |

GEARBOX

DESCRIPTION

The gearbox has five forward and one reverse gear. All gears have synchromesh except reverse gear. All gears are in constant mesh and have helical teeth. Reverse gear teeth are straight cut. The gears are operated by means of a floor-type gear lever connected to the selector shafts by means of a remote linkage. Connection of rear support to gearbox casing is obtained through a couple of elastic supports which reduce to a minimum the transmission of vibrations to the speed control lever.

Differential and gearbox form a single assembly. Crown gear-pinion couple is of the hypoid type and has a ratio of 9/35 or 11/39.

TRANSMISSION RATIOS

Gear	Gearbox ratio	Crown gear and pinion ratio	
		9/35	11/39
		Overall ratio	
1 st	1:3.750	1:14.580	1:13.293
2 nd	1: 2.050	1: 7.970	1: 7.267
3 rd	1:1.387	1: 5.392	1: 4.916
4 th	1: 1.027	2: 3.992	1: 3.640
5 th	1: 0.825	1: 3.207	1: 2.924
RM	1:3.091	1:12.017	1:10.957

REMOVAL AND INSTALLATION

Removal from vehicle

Should the whole drive unit be removed from the vehicle and the two units be thereafter separated, proceed as follows;

1. Remove drive unit from vehicle (refer to: Group 01 - Drive Unit Removal and Installation).
2. Separate gearbox-differential unit from engine unit (refer to: Group 01- Separation and Assembly of the Units).

Installation of vehicle

In case of assembly of groups and installation on vehicle proceed as follows

1. Assemble gearbox differential unit and engine unit (refer to. Group 01 Separation and Assembly of the Units).
2. Assemble drive unit on vehicle (refer to. Group 01 Drive Unit - Removal and Installation).

3. After installing drive unit on vehicle fill up with prescribed oil (AGIP FI Rotra MP SAE 80W90 or IP Pontiac HD 80W90), oil should be fed in slowly till the level reaches the lower rim of fillerhole, check for oil level and fit in plug.

REAR SUPPORT

DISASSEMBLY

Set gearbox-differential unit on

suitable stand provided with bracket and proceed as follows:

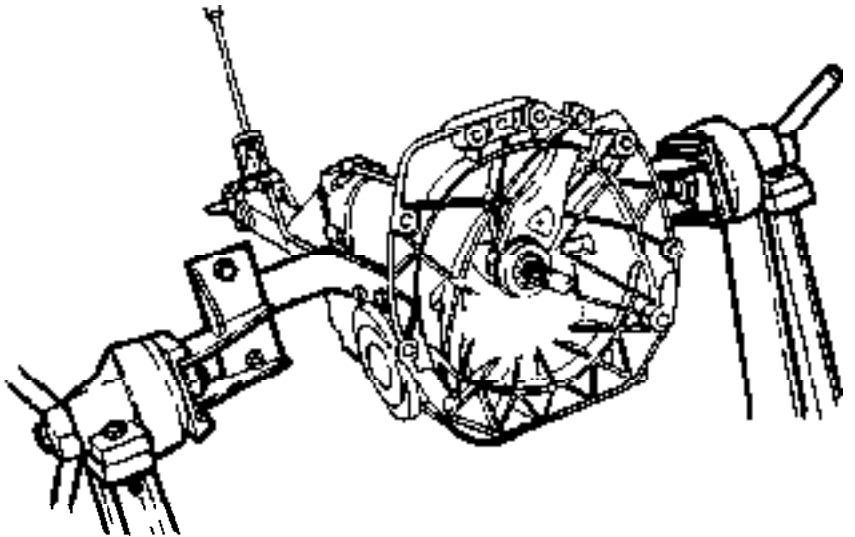

1. Remove remote linkage retaining clip (5) from lever (3) and remove rod. Remove washers (4) and bush (2).

2. Dissassemble gearbox outer linkage from rear support (see. Gearbox Outer Linkage - Disassembly).
3. Disconnect drive unit rear support from flexible supports (1) and (4) which connect it to gearbox-differential casing (2) by unscrewing the two screws (3).

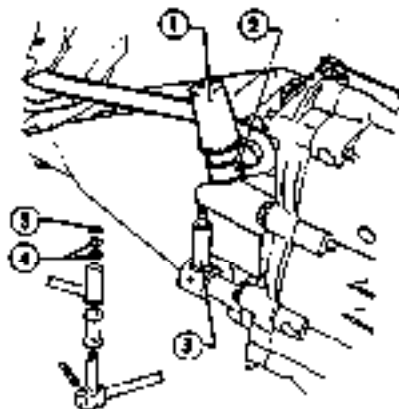

- | | |
|------------------|------------------|
| 1 Remote linkage | 4 Washers |
| 2 Bush | 5 Retaining clip |
| 3 Lever | |

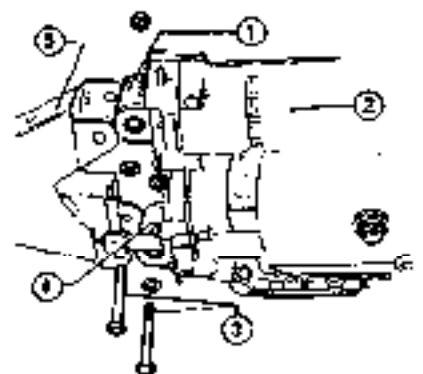

- | |
|-------------------------------|
| 1 Upper flexible support |
| 2 Gearbox-differential casing |
| 3 Screws |
| 4 Lower flexible support |
| 5 Rear support |

4. Remove pin (1) inserted into flexible support (2) and remove the flexible support itself from rear support should its replacement be required.

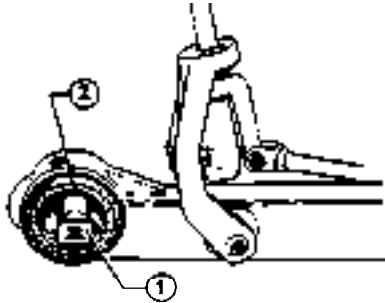

1 Pin 2 Flexible support

5. Unscrew screws connecting flexible supports (2) and (3) to rear cover of gearbox casing (1). Remove flexible supports.

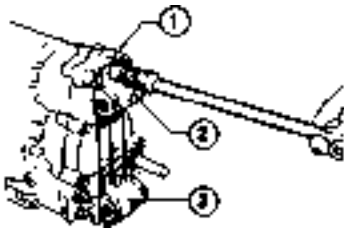

1 Rear cover 2 Upper flexible support 3 Lower flexible support

CAUTION:
Gearbox casing is made of aluminium alloy.
Handle with maximum care to avoid damaging it.

CHECKS AND INSPECTIONS

1. Clean metal parts of rear support with solvent and check for its integrity.
2. Check amount of leverage articulation wear.
3. Check on integrity of rubber bushings, and replace worn or damaged ones.

ASSEMBLY

1. Reassemble end flexible support on rear support, the pair of flexible supports on rear cover, then the rear support itself following the reverse order for disassembly and using the same tools previously used.
2. Reassemble the outer linkage of gearbox on rear support (refer to: Gearbox Outer Linkage - Assembly).

RODS AND FORKS

DISASSEMBLY

1. Remove spring pin securing lever to main selector rod (1) and remove lever.

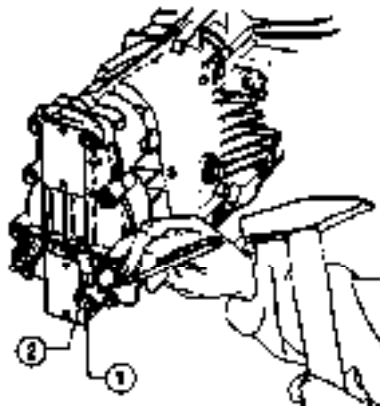

1 Main selector rod 2 Lever

2. Unscrew reverse gear light switch (1) and remove it together with relevant washer from rear cover (2).

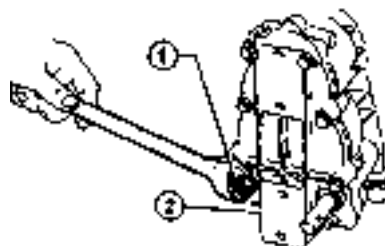

1 Switch 2 Rear cover

3. Unscrew screw (2) and remove plate (3) securing oil bleeder valve to gearbox casing cover and remove valve plug (1) and valve (4) itself.

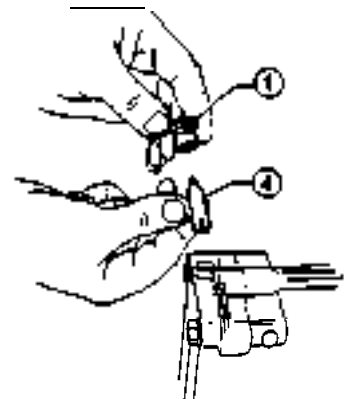
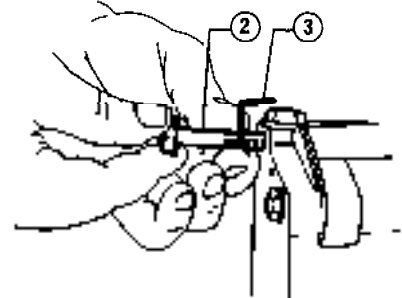

1 Valve plug 2 Screw 3 Plate 4 Valve

4. Unscrew and remove screws (1) fixing rear cover (2) to gearbox casing (3). Use a plastic hammer to loosen cover and remove it together with seal gasket (4).

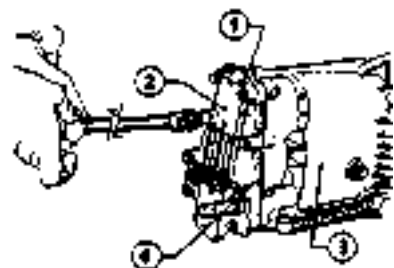

1 Screws 2 Rear cover 3 Gearbox casing 4 Seal gasket

GEARBOX

5. Remove main selector rod (2) seal ring (3) from rear cover (1)

Should removal of seal ring take place while gearbox is fully assembled (on stand or vehicle), special tool A.3.0429 must be used.

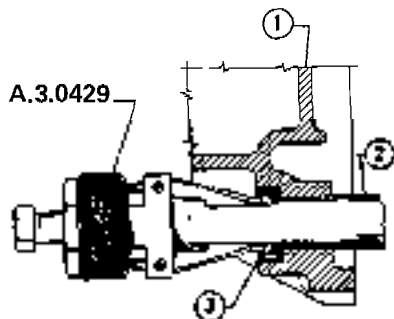

1 Rear cover 3 Seal ring
2 Main selector rod

5. Remove guide pin (2) for main selector rod (3) return spring (1).
7. Unscrew and remove screws (4) with relevant fixing washers from oil sump; remove oil sump (5) together with relevant gasket.

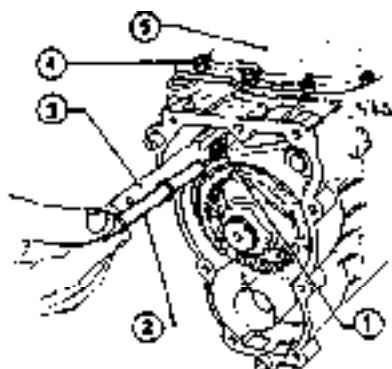

1 Return spring 4 Screws
2 Guide pin 5 Oil sump
3 Main selector rod

8. Unscrew screw (1) securing 1st and 2nd speed control fork (7) on relevant rod (2) and screw (6) securing 1st and 2nd speed lever (5). Remove lever (5) from gearbox casing. Loosen and remove screw (3) fixing 3rd and 4th speed control fork (4) on relevant rod.

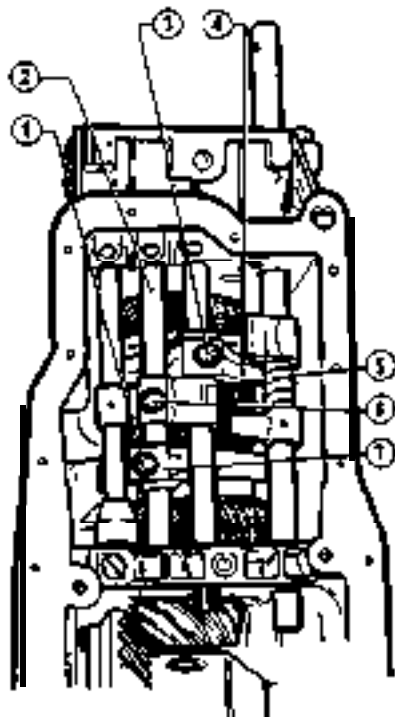

1 Screw
2 1st and 2nd speed rod
3 Screw
4 3rd and 4th speed control fork
5 1st and 2nd speed lever
6 Screw
7 1st and 2nd speed control fork

9. Use tool A.3.0322 to remove the following spring pins:

- Pin (3) securing reverse gear and 5th speed lever on rod (4)
- Pin (5) securing safety lever on rod (2)
- Pin (1) securing selector lever on rod (2).

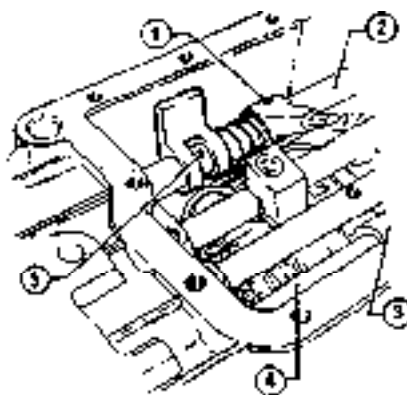

1 Speed selector lever pin
2 Main selector rod
3 Reverse gear and 5th speed lever pin
4 Reverse gear and 5th speed rod
5 Safety lever pin

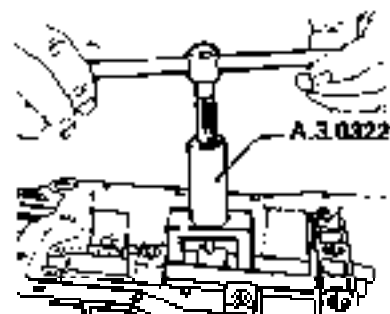

10. Remove main selector rod (4) and recover selector (1), spring (8) and lever (2).

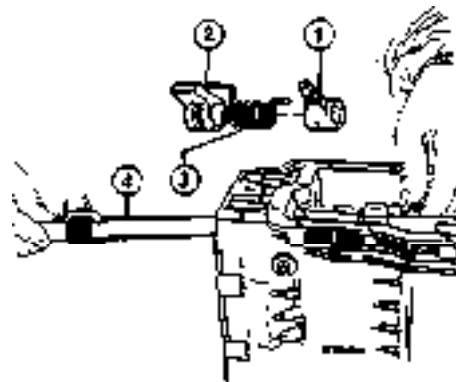

1 Selector 3 Spring
2 Lever 4 Main selector rod

11. Engage 5th speed and remove 5th speed and reverse gear rod (4) lock ring (2) place on central support (1). Unscrew and remove the two balls securing plug (3) then remove the balls themselves.

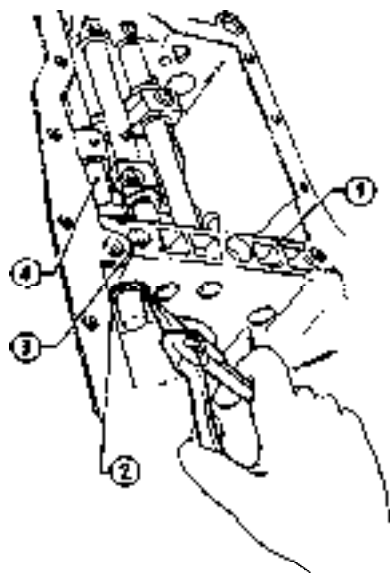

1 Central support 4 5th speed and reverse gear rod
2 Lock ring
3 Securing plug

12. Remove 5th speed and reverse gear rod (1) together with 5th speed control fork (3) and sleeve (2).

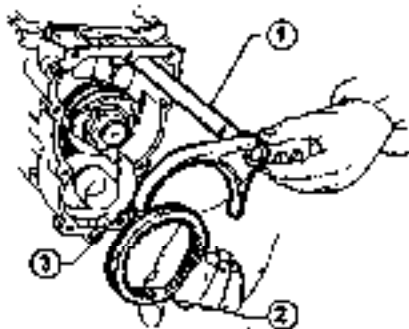

1 5th speed and reverse gear rod
2 Sleeve
3 5th speed control fork

13. Use a driftpin (3) to remove 3rd and 4th speed rod (2) and recover its relevant fork (1) from synchronizer sleeve. Proceed as above for removal of 1st and 2nd speed rod (5) together with fork (4).

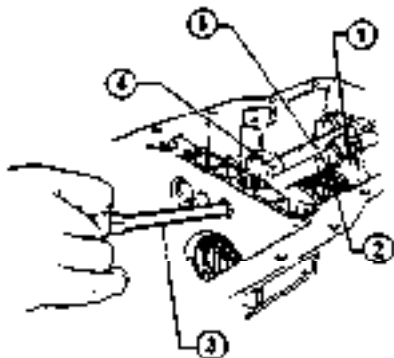

1 3rd and 4th speed control fork
2 3rd and 4th speed rod
3 Driftpin
4 1st and 2nd speed control fork
5 1st and 2nd speed rod

The withdrawal 3rd and 4th speed rods and 1st and 2nd speed rods proceeds, as the millings appear, respectively circular and rectangular shaped, in correspondance with the rear support of the gearbox, it is necessary to rotate the rods to prevent the balls from getting inserted into the millings themselves, preventing thus the withdrawal from being completed.

14. Remove the following components from the seats on the rear support of gearbox casing:

- The three detent balls (2) from the three rods
- The two interlock plungers (3) after unscrewing screw (4) which give access to a channel which can be inspected by a screwdriver able to move the interlock plungers considered.

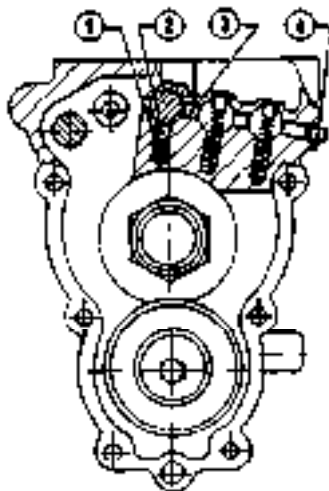

1 Spring
2 Detent balls
3 Interlock plungers
4 Screw

During removal of speed rods, depending upon the operation to be carried out, it may be useful to keep in their seats detent balls and interlock plungers: use for this purpose tool A.3.0303.

CHECKS AND INSPECTIONS

Wash parts carefully before operating on them. Superficial faults, wear and efficiency of certain organs can be better detected.

1. Inspect whether speed control forks are not excessively worn or warped.
2. Inspect whether rods are not warped.
3. Inspect whether slots on rods bear any nicks.
4. Inspect whether detent balls and interlock plungers bear any nicks or seizing marks.

ASSEMBLY

1. Set the corresponding 1st-2nd and 3rd-4th speed control forks on relevant synchronizer sleeve.
2. Insert dummy rod. A.3.0303 into assembly seat of 3rd and 4th speed rod. Assemble through hole on dummy rod a new spring with relevant detent ball, after greasing, then by means of the driver tool A.3.0309 insert and compress them so as to be able to move backward tool rod to keep them into position.
3. Insert relevant rod into gearbox casing seat pushing at the same time tool rod. Complete assembly of rod by introducing it into the small hub of the fork and by aligning the hole on the latter with the slot on the rod.

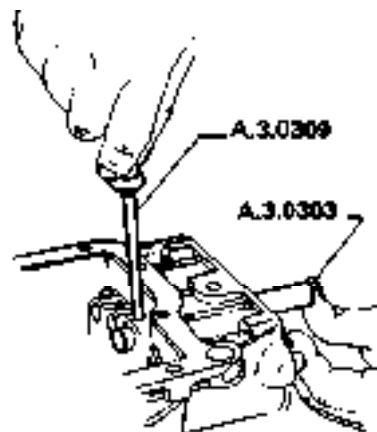

4. Grease and assemble the two interlock plungers in the horizontal seats on the gearbox casing using guide tool A.3.0304 and driver tool A-3.0309.

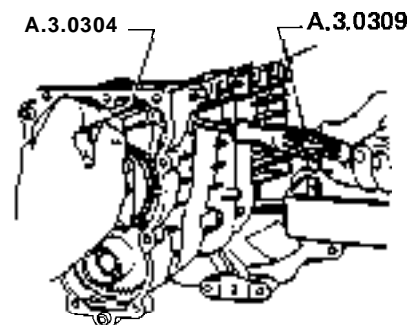

GEARBOX

5. Grease and assemble spring and 1st-2nd speed rod detent ball, using tools A.3.0304 and A.3.0309. Grease and insert relevant ball into radial hole on rod. Insert then rod itself into its seat on the gearbox casing, paying attention to the reciprocal position of milling and of detent ball, and make it pass through the small hub of relevant fork.

6. Use relevant securing plug to close interlock plunger hole.

7. Grease and use tools A.3.0303 and A-3.0309 to assemble spring and 5th speed and reverse gear rod detent ball.

Insert then rod (2), together with 5th speed control fork (3), into small hubs of 5th speed and reverse gear lever (1) and into reverse gear control fork (4) together with relevant sliding sleeve.

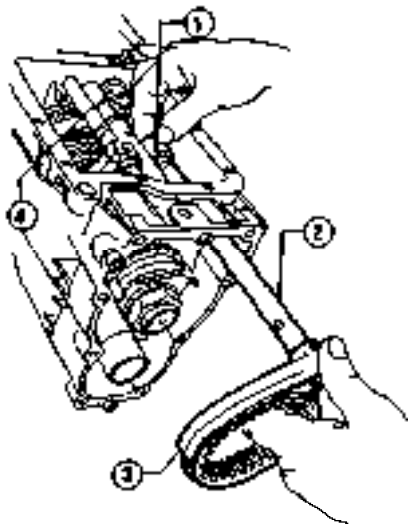

- 1 5th speed and reverse gear lever
- 2 5th speed and reverse gear rod
- 3 5th speed control fork
- 4 Reverse gear control fork

8. Align axes of holes and insert spring pin of 5th speed and reverse gear lever by means of tool A.3.0322.

Insert the two balls into their seats on central support of gearbox casing

together with relevant spring, then lock securing plug and unscrew it by one quarter of a rotation.

Mount lock ring of 5th speed and reverse gear rod on the end of the rod itself, on the differential side.

9. Assemble partially main selector rod, by introducing it from the rear side of the gearbox casing, insert it then into the selector lever, into the spring and into the lever. Complete then introduction of rod.

Align axes of lever holes with the corresponding ones on rod and mount spring pins using tool A.3.0322.

The speed selector lever pin (2) must be shim fitted while the other lever's pin (1) must be fitted as a striker on the edges of the pin itself, with the excess portion of the pin protruding on the selector's side.

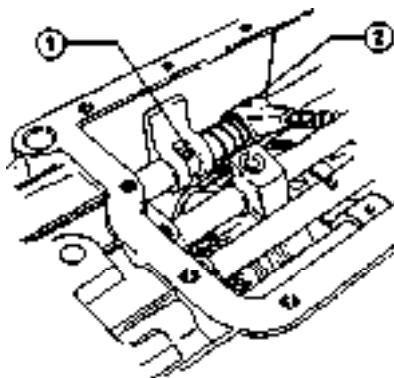

- 1 Pin
- 2 Pin

10. Fit the guide pin for the main selector rod return spring.

11. Position the 1st-2nd speed lever (8) on the relevant rod (2). Turn rod (2) so that specified "S" clearance is established between lever (8) and rod (5).

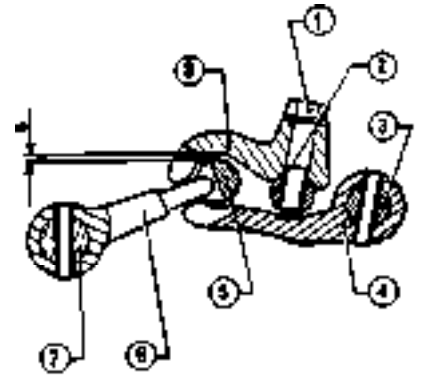

- 1 Screw
- 2 1st-2nd speed rod
- 3 6th speed and R.G. rod
- 4 R.G. fork
- 5 3rd-4th speed rod
- 6 Selector
- 7 Main selector rod
- 8 1st-2nd speed lever

"S" clearance between 1st-2nd speed lever and 3rd-4th speed rod
 $1.4 \div 1.9 \text{ mm} (0.055 \div 0.075 \text{ in})$

12. Align the holes and then fit the retaining screw (1). Tighten it according to specified torque.

(T): Tightening torque
 Screw securing 1st-2nd speed selector lever to rod:
 $25 \div 26 \text{ N}\cdot\text{m}$
 $(2.5 \div 2.7 \text{ kg}\cdot\text{m})$
 $18.07 \div 19.52 \text{ ft}\cdot\text{lb}$

13. For gear synchronizing center 1st-2nd and 3rd-4th speed control forks - in that order - on toothed rings with the help of a gauge; now fit retaining screws and tighten them according to specified torque.

CAUTION:
 Prior to tightening, thoroughly clean the retaining screw thread with OMNIFIT surface-active agent and then coat it with OMNIFIT 150 H cernent

(T): Tightening torque
 Screw securing fork to 1st-2nd and 3rd - 4th speed rod.
 $21 \div 23 \text{ N}\cdot\text{m}$
 $(2.1 \div 2.3 \text{ kg}\cdot\text{m})$
 $15.10 \div 16.63 \text{ ft}\cdot\text{lb}$

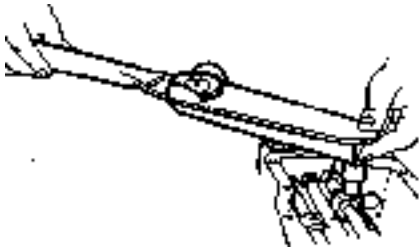

Check working condition of spring-plunger-rod assembly making sure that speed selection is smooth and that speeds do not jump out of their position and become disengaged.

14. Fit oil sump, with a new gasket, on the gearbox casing and tighten relevant screws.

15. Position rear cover, with a new gasket, on both gearbox casing centering seats; fit the oil bleeder valve with relevant retaining plate, and then tighten all screws.

16. Apply a coating of ISECO Molykote BR2 grease to the main selector rod seal ring as well as to its work seat on the rod.

Using tool A.3.0294, fit the seal ring on the rod.

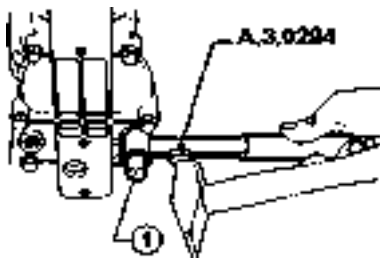

1 Main selector rod

17. Fit the relevant lever on the main selector rod and then, using a punch, fit the retaining pin.

18. Fit reverse gear switch on rear cover.

- Ⓣ: Tightening torque
 R.G. switch to gearbox casing
 40 ÷ 49 N-m
 (4 ÷ 4.9 kg-m
 28.92 ÷ 35.43 ft-lb)

TESTING

Check working condition of spring-plunger-rod assembly making sure that speed selection is smooth and that speeds do not jump out of their position and become disengaged.

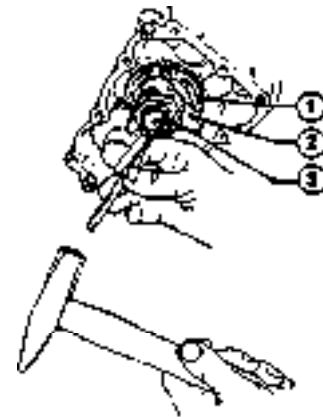

1 5th speed gear 3 Nur
 2 Hub

SHAFTS AND GEARS

DISASSEMBLY

Pinion shaft gears

1. Remove rods and forks (refer to: Rods and Forks - Disassembly).
2. Acting on relevant sleeves, engage two speeds in order to prevent pinion from turning.
3. With a punch, eliminate all caulking from the gear train to pinion locking nut (3).
4. With spanner A-5.0196, loosen thenut and remove the hub (2), the 5th speed gear (1) with relevant synchronizing unit, and the bushing.

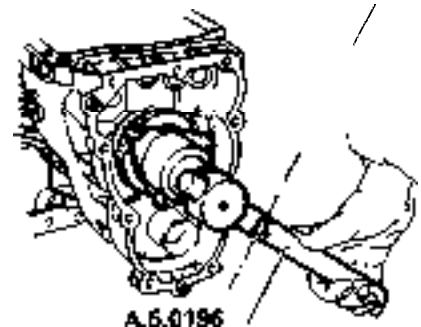

5. Remove differential casing (Refer to: Group 17 - Differential Differential Casing).
6. Slowly push pinion shaft toward the differential casing and remove all parts making up the train on the pinion (1st, 2nd, 3rd and 4th speeds), being careful to mark the sequence and the position of gear bushings to be later followed during reassembly.

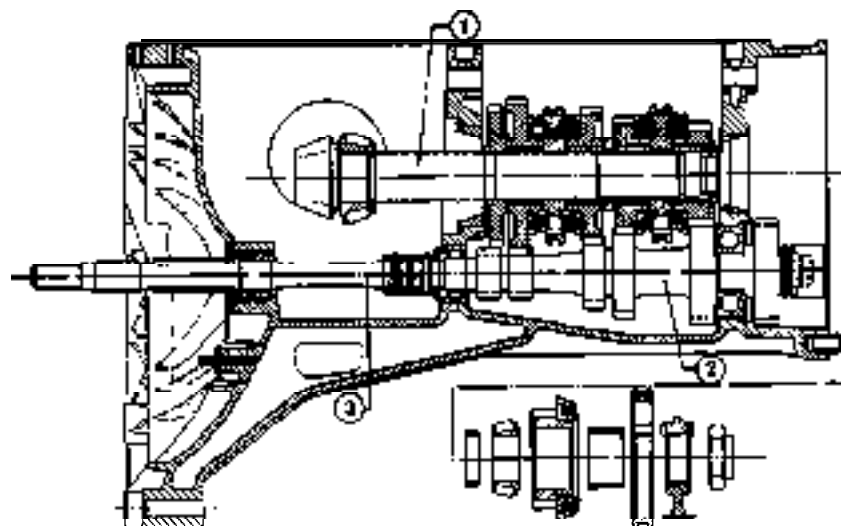

1 Pinion 3 Direct drive shaft
 2 Primary shaft

GEARBOX

CAUTION:

If friction between the pinion and the inner race of the rear taper roller bearing hinders withdrawal of the pinion shaft, use tool A.3.0296.

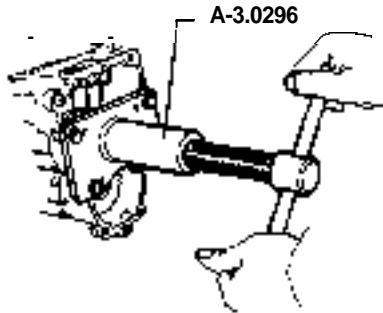

7. Remove the pinion (3), with relevant taper roller bearing (1) and adjusting washer (2), from the gearbox-differential casing.

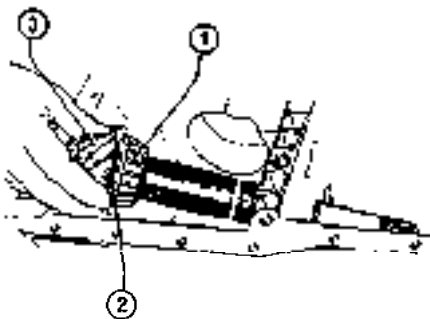

- 1 Taper roller bearing
- 2 Adjusting washer
- 3 Pinion

8. With tool A.3.0296 remove the rear bearing outer race from the gearbox-differential casing.

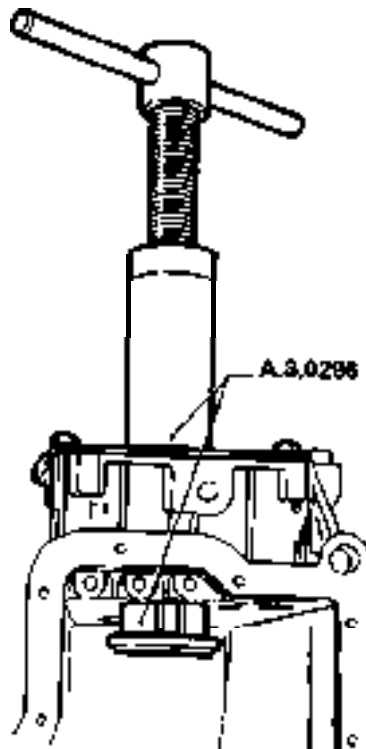

9. Using tools A.3.0296 and A.3.0297, remove the pinion front bearing outer race from the gearbox-differential casing.

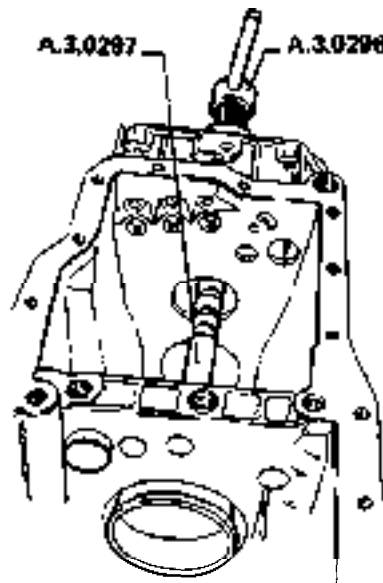

10. With the help of a press and of plates A-3.0306, remove the front bearing (1) inner race and the adjusting washer (2) from the pinion shaft (3).

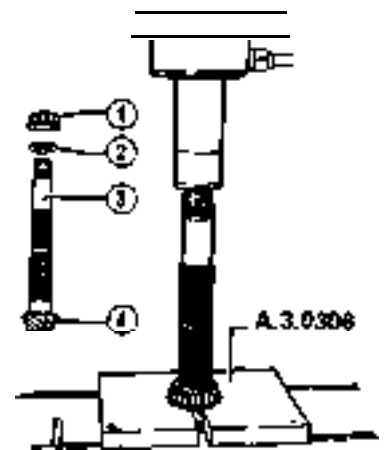

- 1 Pinion shaft front bearing
- 2 Adjusting washer
- 3 Pinion shaft
- 4 Pinion

Synchronizing units

Remove the lock ring (1) and then remove in sequence: the synchronizer ring (2), the guide sector (3), the locking sector (4), and the retainers (6).

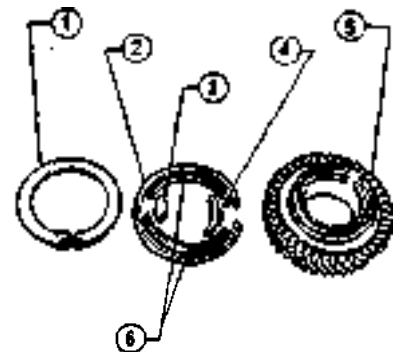

- 1 Lock ring
- 2 Synchronizer ring
- 3 Guide sector
- 4 Locking sector
- 5 Gear
- 6 Retainer

The 1 st speed synchronizing unit has only one retainer.

Direct drive shaft

1. Remove the lock ring (1) of the clutch drive thrust bearing support and then remove the support (2).

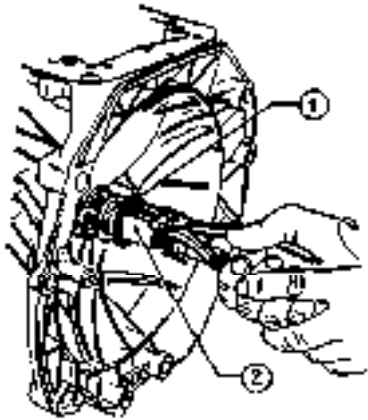

1 Lock ring
2 Thrust bearing support

2. Remove the direct drive shaft oil seal ring located on the front of the gearbox casing.

To remove oil seal ring, with mounted unit, operate as per figure making use of tool A.3.0452.

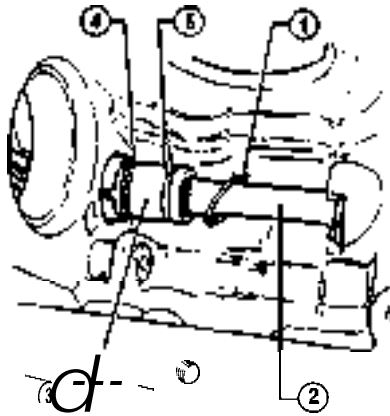
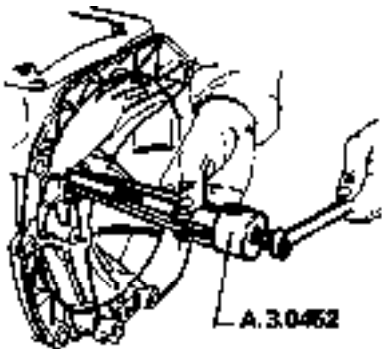

1 Pin retaining spring ring 3 Joint
2 Direct drive shaft 4 Spring ring 5 Pin

4. Having removed the direct drive shaft, if necessary, remove the direct drive shaft bush with the help of tool A.3.0291. This tool removes also the oil seal ring.

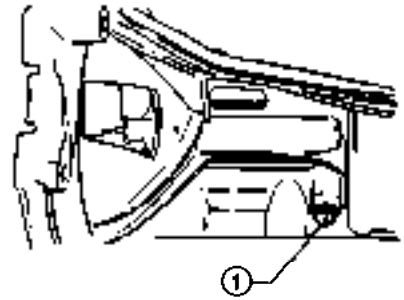
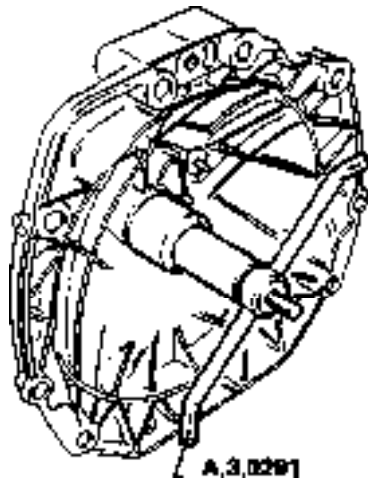

1 R.G. shaft retaining screw

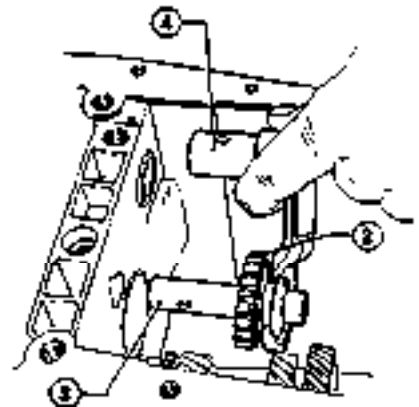

2 Reverse gear 4 R.G. control fork
3 R.G. shaft

Primary shaft

1. Fit lock tool A.2.0300 at the end of the primary shaft (1) in order to prevent it from turning.

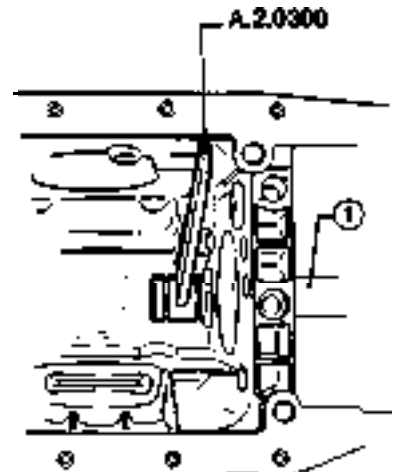

1 Primary shaft

3. Remove the spring ring (1) retaining the pin (5) connecting the direct drive shaft (2) to the joint (3).

Remove the pin in question and pull out the direct drive shaft. Now remove the spring ring (4) retaining the pin that connects the primary shaft to the joint; remove this latter pin and pull out the joint from the primary shaft.

Reverse gear shaft

1. Loosen and remove the R.G. shaft (3) retaining screw (1) and then remove the shaft, with relevant sliding gear (2) and R.G. fork (4) from its location on gearbox-differential casing.

GEARBOX

2. Loosen the screw securing the primary shaft to its rear bearing and remove the oil deflector.
3. Using tool A.3.0495 remove the 5th speed driving gear ①.

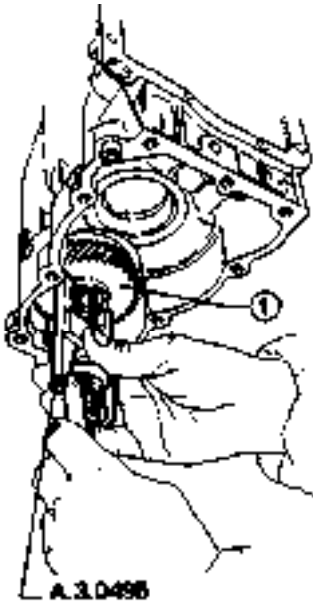

1 5th speed driving gear

4. Pull out the tongue securing the 5th speed driving gear to the primary shaft.
5. Loosen and remove the screw ⑤ securing the primary shaft ③ front: floating bearing ④.

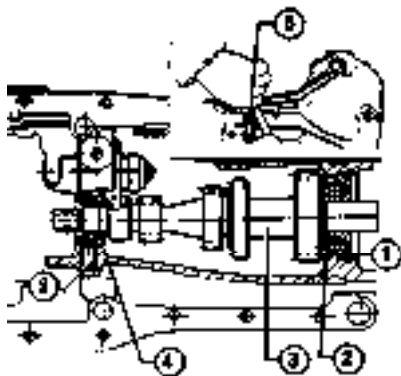

1 Bearing lock ring 4 Front bearing
2 Rear bearing 5 Bearing retaining screw
3 Primary shaft

6. Remove lock ring ② from rear bearing ①.

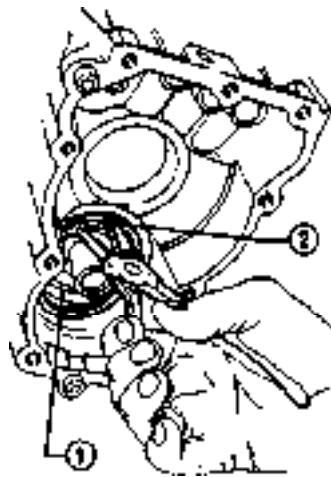

1 Ball bearing 2 Lock ring

7. Fit pinion ① back into the gearbox-differential casing.

8. Fit rear bearing on pinion shaft ①, together with the first section (fork shaped) of tool A.3.0490, at the location of the 4th speed driving gear. Now fit the second section of tool A.3.0490 locking it on the pinion, by means of the relevant nut, at the location of the 5th speed driven gear.

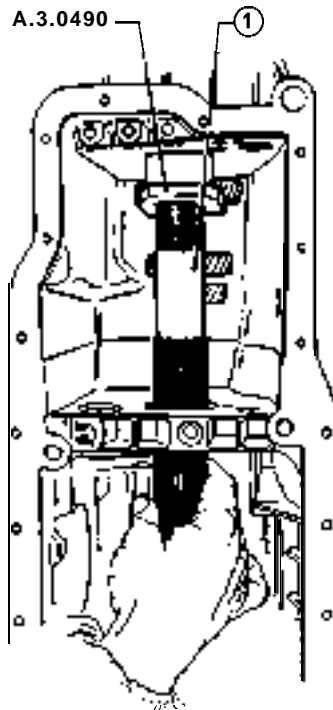

1 Pinion

9. Fit tool A.3.0296 on the gearbox-differential casing and then fit the A-3.0492 end piece.

Carefully tighten the screws securing tool A.3.0296 to the gearbox-differential casing to avoid damaging the casing's threads.

10. With the above mentioned tool, push the primary shaft toward the differential casing.

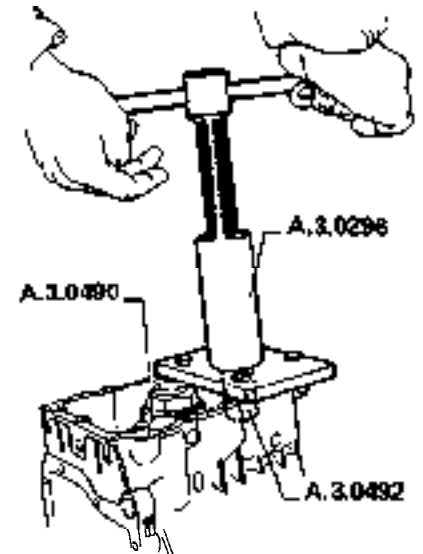

- Now remove the front floating bearing from the primary shaft.
11. Remove the 4th speed driving gear and relevant tongue.

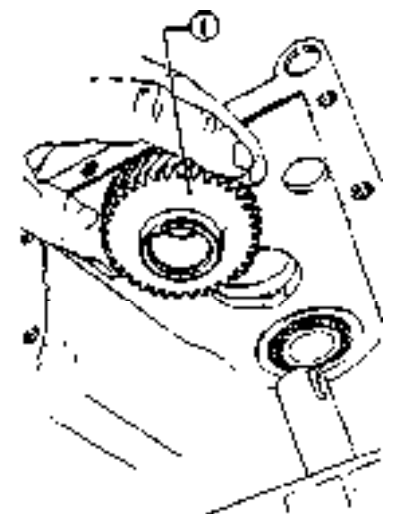

1 4th speed driving gear

12. Keeping tool A.3.0296 in place, remove pinion shaft with all the parts that are fitted on it; now totally remove tool A.3.0490.

13. Completely screw the tool A.3.0296 and insert tools A.3.0491 and A.3.0500 on its nut thread. Unscrew tool A.3.0296 and remove primary shaft rear bearing from its seat, then separate it from the tool.

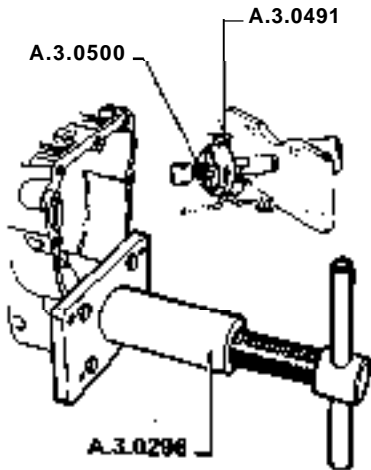

14. Remove the primary shaft ① from the gearbox-differential casing passing through the seat of the rear bearing.

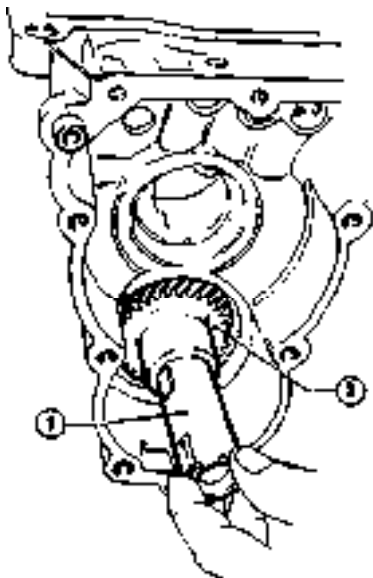

1 Primary shaft 2 3rd speed gear

CHECKS AND INSPECTIONS

Thoroughly wash all parts and visually check them with extreme care for any surface flaws.

Gears and splines

1. Check that teeth contact pattern of primary shaft and bevel pinion gears extends to the entire working surface. Unevenly worn gears or gears with broken teeth must be replaced making sure that relevant mating gears have not been damaged. Follow the same checking procedure for splines of primary shaft, direct drive shaft, and of the pinion.
2. Also check that above mentioned toothings as well as the groove on the synchronizing ring do not show any scores, evidence of pitting or excessive wear. Replace all parts that are not flawless.

Bushings

Check pinion bushings for excessive wear making sure that working surfaces in contact with gears do not show any scratches or evidence of pitting. Replace all parts that are not flawless.

Synchronizing unit

Check sliding surfaces for scores and make sure that sleeves slide smoothly on relevant hubs; check synchronizing rings for excess wear.

Bearings

1. Carefully inspect all bearings by slowly rotating them: no vibrations, noise or sticking should be noticed if bearings are in good working condition.
2. Check surface of all rings and rotating parts making sure there are no scores, marks or roughness due to friction of foreign matter. Replace all parts that are not flawless.

Reverse gear shaft

If any of the parts making up the reverse gear shaft assembly are defective or damaged, replace them with new ones available as spare parts.

ASSEMBLY

Primary shaft

1. First fit on the primary shaft the tongue for keying of the 4th speed driving gear.
2. Fit the shaft in its seat on the gearbox-differential casing and then fit the 4th speed gear on the shaft.
3. Lock the primary shaft's front end with tool A.2.0300 (refer to: Primary Shaft - Disassembly).
4. Fit tool A.3.0300 on the primary shaft's rear end using it to key the 4th speed gear.

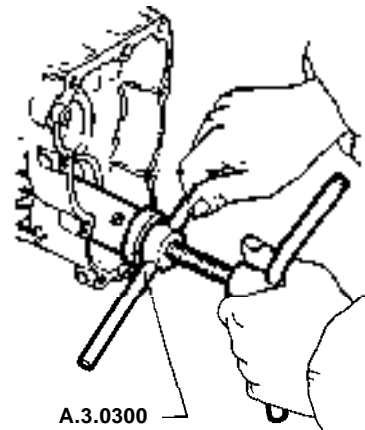

5. Using tools A.3.0491 and A.3.0296, fit rear ball bearing on primary shaft.

Carefully tighten screws of tool A.3.0296 on the gearbox casing to avoid damaging the casing's threads.

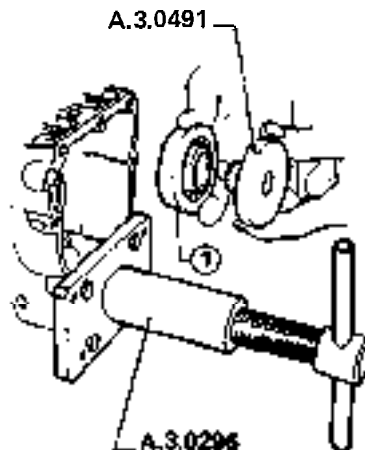

1 Ball bearing

GEARBOX

6. With the help of suitable plyers fit the lock ring in its seat on the primary shaft's rear bearing support.

Make sure the lock ring is properly lodged in its seat.

7. Keeping the primary shaft locked by means of tool A.2.0300, fit tool A.3.0300 on same shaft's rear end; center the shaft in the rear ball bearing.

Fit primary shaft on rear bearing.

8. Fit roller bearing on the primary shaft's front end being careful to align the hole of the bearing's outer race with the corresponding hole in the gearbox-differential casing. Fit securing screw into the hole in the gearbox-differential casing.

Fit securing screw into the hole and fully tighten it.

Having completed primary shaft assembly, check and make sure it turns freely on the bearings, without sticking.

9. Fit on primary shaft the longue for keying of the 5th speed driving gear.

10. With tool A.3.0300 fit the 5th speed gear in its seat on the primary shaft by the gearbox casing's outer rear side.

11. Fit oil deflector in its seat on the 5th speed gear and tighten the primary shaft retaining screw, without fully locking it.

Reverse gear shaft

1. Fit reverse gear shaft, with relevant sliding gear and driving fork into its seat on gearbox casing.

2. Tighten to specified torque the screw securing the R.G. shaft to the gearbox casing.

Ⓣ: Tightening torque
R.G. shaft to gearbox casing retaining screw
19 ÷ 24 N·m
(1.9 ÷ 2.4 kg·m)
13.74 ÷ 17.36 ft·lb)

Pinion shaft gears

1. Coat with grease (AGIP FI Grease 33 FD) the outer surface of the pinion taper roller bearings

outer races and then fit them on the gearbox casing, using the same tools used during disassembly (Tool A.3.0296 for the rear bearing race, and tool A.3.0296 - together with tool A.3.0297 - for the front bearing race).

CAUTION:

Take special care during assembly making sure that bearing races are exactly flat against casing surface.

2. Fit the proper shim, selected in advance, on the pinion shaft (refer to: Adjustments - How to determine pinion height).

Using a press and tool A.3.0307, fit the taper roller bearing inner race on the pinion shaft.

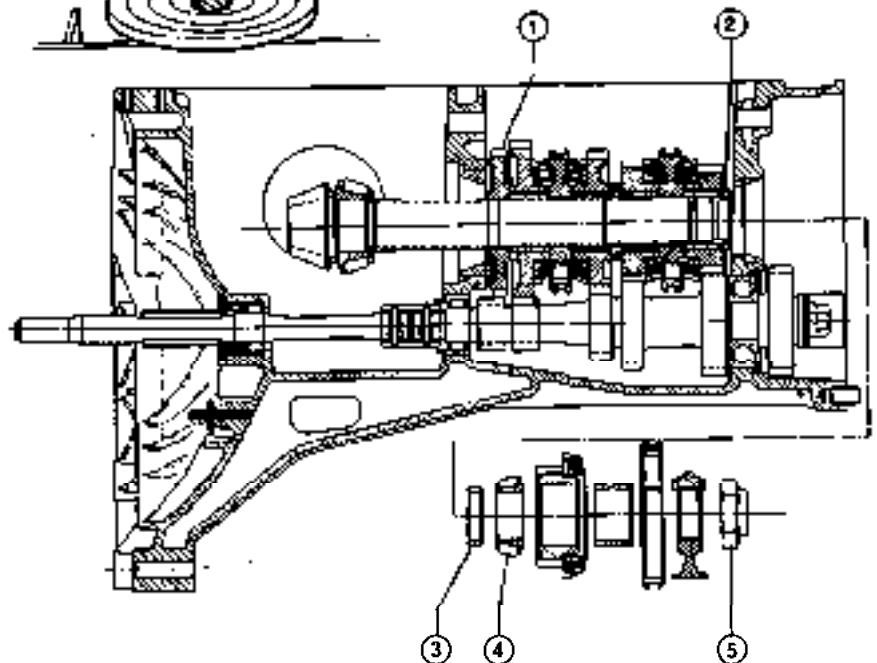
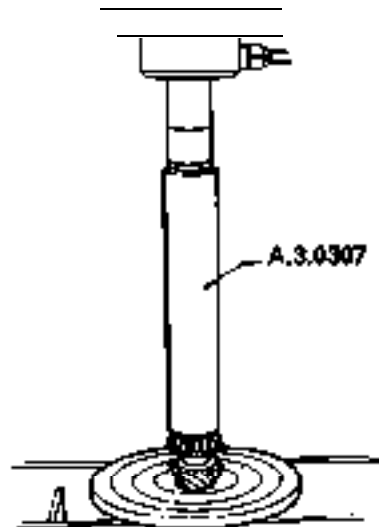

- | | |
|----------------------|-----------------------------|
| 1 Reverse gear | 4 Rear taper roller bearing |
| 2 4th speed shoulder | 5 Lock nut |
| 3 Standard shim | |

3. If previously disassembled for overhaul purposes, reassemble synchronizing units (refer to: Synchronizing units).

4. Apply the prescribed engine oil to outer surface of bushings and then fit them on gears according to their relevant position at time of disassembly thus restoring the original working surface pattern.

5. Partially insert bevel pinion into the gearbox casing and then fit all parts making up the train, while slowly pushing the pinion in till it reaches its final position. During this operation be sure to follow the sequence and positioning show in the relevant figure, paying special attention to the R.G. driven gear ① and to the 4th speed shoulder washer ②.

Fit standard shim A.4.0141 ③ (9.60 mm (0.378 in) thick) and the inner race of the rear taper roller bearing ④, making sure that it fits flat against the shoulder washer.

In case of friction between the bearing's inner race and the pinion, use tools A.3.0300, A.3.0301 for easier fitting.

6. Fit the bushing and the hub of the 5th speed driven gear and then tighten by hand the pinion gear train lock nut.

7. Engage two gears and then tighten the nut according to specified torque, without caulking.

T: Tightening torque
Pinion gear train to pinion shaft lock nut
 220.5 ÷ 245 N · m
 (22.5 ÷ 25 kg · m
 162.70 ÷ 180.77 ft · lb)

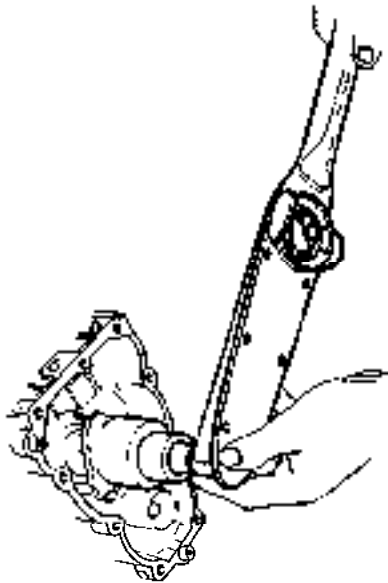

It is advisable not to exchange the parts belonging to the different synchronizing units.

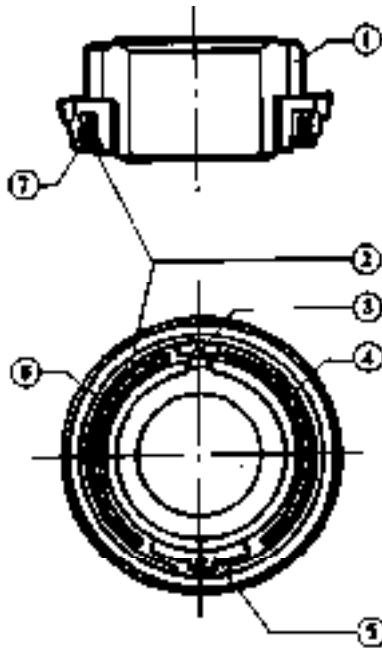

- | | |
|----------------|----------------------|
| 1 Gear | 5 Locking sector |
| 2 Retainer | 6 Synchronizing ring |
| 3 Guide sector | 7 Lock ring |
| 4 Retainer | |

2. Now follow the same procedure for the 1st speed gear remembering, however, that in this case there is only one retainer (refer to: Disassembly- Synchronizing units).

ADJUSTMENTS

How to determine pinion height

CAUTION:
 Use only metric system in order to avoid confusion in computations.

To determine pinion height, and therefore shim thickness, proceed as follows:

1. Fit inner race of the pinion shaft front taper roller bearing on dummy pinion A.4.0142.
2. Insert dummy pinion in gearbox casing.

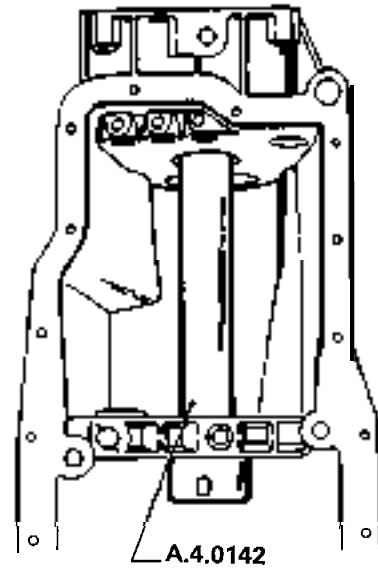

3. Fit rear taper roller bearing inner race (2) and relevant lock nut onto dummy pinion (1).

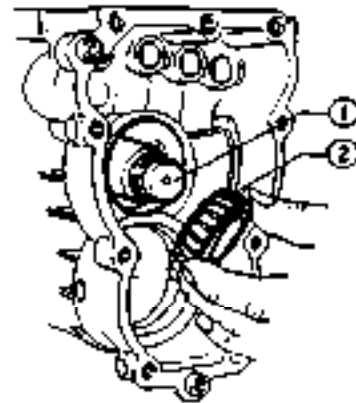

- 1 Dummy pinion
- 2 Taper roller bearing inner race

4. Tighten the nut according to specified rolling torque using coupling tool A.2.0274, 1 dm. dia. sheave C.5.0124 and weight C.2.0037.

T: Dummy pinion rolling torque

- a. For original bearings being used again:
 3 ÷ 6 N · dm
 (0.3 ÷ 0.6 kg · dm
 0.217 ÷ 0.434 ft · lb)
- b. For replacement bearings (new)
 12 ÷ 14 N · dm
 (1.2 ÷ 1.5 kg · dm
 0.867 ÷ 1.085 ft · lb)

8. Now select the shim for final fitting (refer to: How to determine Pinion Shaft Taper Roller Bearing Pre-load).

Synchronizing units

1. As far as 2nd, 3rd, 4th and 5th speed gears are concerned fit retainers (2) (4) and on gear body (1) placing locking sector (5) and guide sector (3) between them. Fit synchronizing ring (6) on retainers and sectors and then lock into place all parts with relevant lock ring (7).

GEARBOX

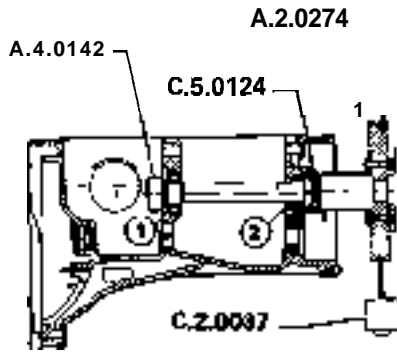

- 1 Front taper roller bearing inner race
- 2 Rear taper roller bearing inner race

- 5. Turn dummy pinion a few times in both directions to allow bearings to settle.
- 6. Fit a centesimal dial gauge to bracket A.4.0136 and reset it by means of reference gauge C.6.0161.

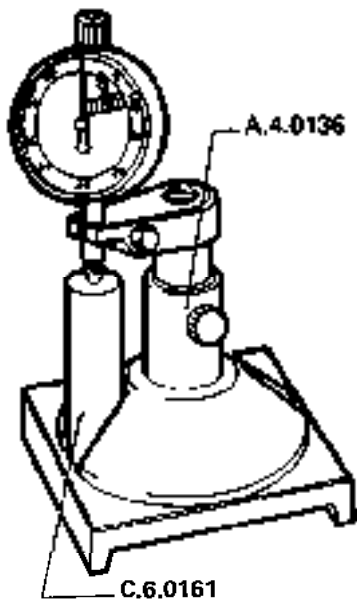

- 7. Fit crown axis reference tool C.6.0162 into the differential carrier seat; tighten, in bias sequence and according to specified torque, the four screws securing it to the gearbox-differential casing.

Ⓣ: Tightening torque
Screws securing tool C.6.0162 to gearbox-differential casing:
40 ÷ 49 N·m
(4 ÷ 4.9 kg·m
28.92 ÷ 35.43 f-t-lb)

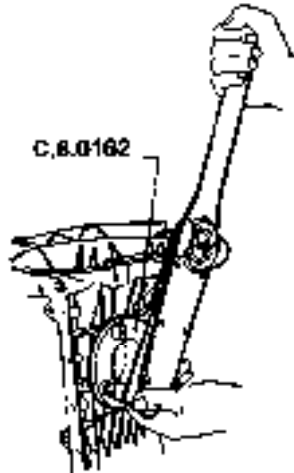

- 8. Place the differential carrier, with dial gauge, on the head of dummy pinion and then take reading of "L₁" value.

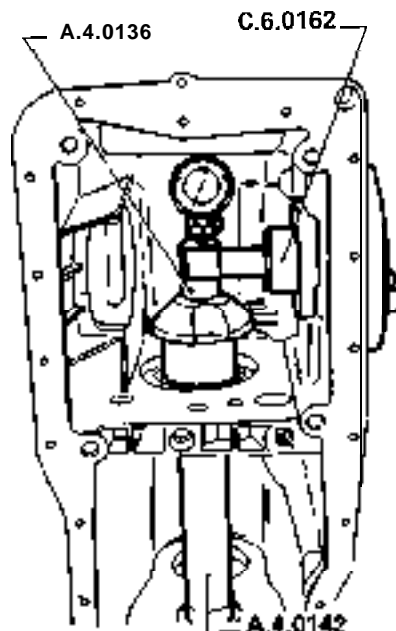

- 9. Repeat above operation by fitting tool C.6.0162 into the seat of the opposite side differential carrier and take reading of "L₂" value.
- 10. Read dimension "C" (plus or minus) etched on pinion.

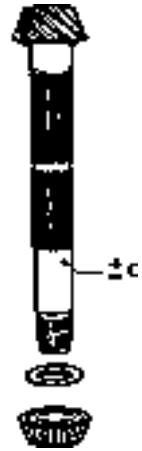

- 11. Determine as follows the "S" thickness of the shim that is to be fitted behind the pinion head:

$$s = \frac{L_1 + L_2}{2} - (\pm C)$$

- 12. Among the various shims available as spare parts, select the one with thickness nearest to the value determined as per above instructions.

Example:

L₁ = 0.86
L₂ = 0.88
c = 0.13

$$S = \frac{L_1 + L_2}{2} - (\pm C) = \frac{0.86 + 0.88}{2} - (0.13)$$

(1)	0.86
	+ 0.88
	1.74
(2)	1.74 : 2 =
	0.67
(3)	0.67
	- 0.13

Computed shim thickness s = 0.74

Selected shim thickness S = 0.75 m m

Shim thickness thus determined in this one ensuring correct pinion height since readings have been taken with pinion in its actual operating position.

GEARBOX

T: Rolling torque of pinion with gear train.

- a. For original bearings being used again
 - $4 \div 7 \text{ N}\cdot\text{dm}$
 - $(0.40 \div 0.70 \text{ kg}\cdot\text{dm})$
 - $0.289 \div 0.506 \text{ ft}\cdot\text{lb}$
- b. For replacement bearings (new)
 - $13 \div 16 \text{ N}\cdot\text{dm}$
 - $(1.3 \div 1.6 \text{ kg}\cdot\text{dm})$
 - $0.939 \div 1.157 \text{ ft}\cdot\text{lb}$

In case of rolling torque values greater or lower than specified ones, correct them by fitting a rear shim either 0.05 mm thinner or thicker than the one previously fitted. In this instance, rechecking of rolling torque is required.

11. Caulk the nut with punch and hammer.

12. First prevent shafts from rotating by engaging two speeds and then tighten the screw securing the oil deflector to the primary shaft according to specified torque.

T: Tightening torque

- Oil deflector retaining screw
- $69 \div 85 \text{ N}\cdot\text{m}$
 - $(7 \div 8.7 \text{ kg}\cdot\text{m})$
 - $50.61 \div 62.91 \text{ ft}\cdot\text{lb}$

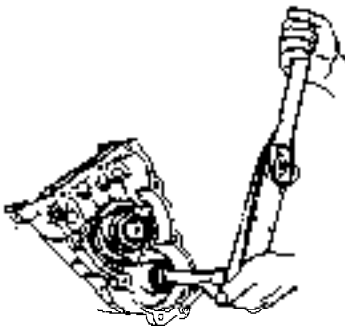

Direct drive shaft

1. If previously disassembled, fit direct drive shaft bushing **1** to gearbox casing using tool A.3.0308.

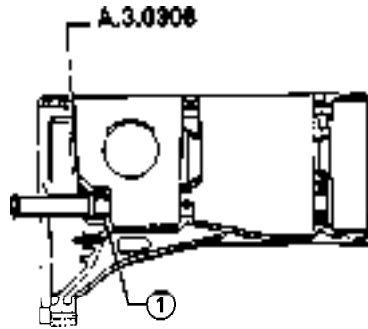

1 Bushing

2. Fit bushing on primary shaft making sure that holes for subsequent pin fitting are aligned; fit the pin and a new retaining spring ring.

3. Insert direct drive shaft into its seat and connect it to the bushing by fitting the pin and a new retaining spring ring.

Make sure that retaining spring rings are properly lodged in their respective seats so as to prevent pins from dropping out.

4. After having applied grease (ISECO: Molykote BR2) to its sealing lip and to its work seat on the shaft, fit a new oil seal ring on the direct drive shaft with the help of tool A.3.0323. During this operation be careful not to damage the sealing lip of coupling splines.

Use tool A.3.0453 to assemble oil seal ring on direct drive shaft, on assembled unit.

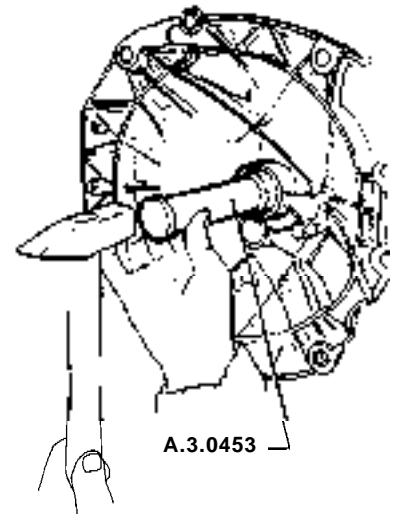

CAUTION:

Cover direct drive shaft splines with tape.

5. Fit the clutch drive thrust bearing support and secure it to its seat on the differential casing by means of the relevant lock ring.

Make sure that lock ring is correctly lodged; check that its tongues are facing the sleeve seat and thus pressing it on the casing.

TESTING

Check that hubs and synchronizing rings are in perfect working condition and that engagement of gears is noiseless and easy.

DIFFERENTIAL CARRIERS

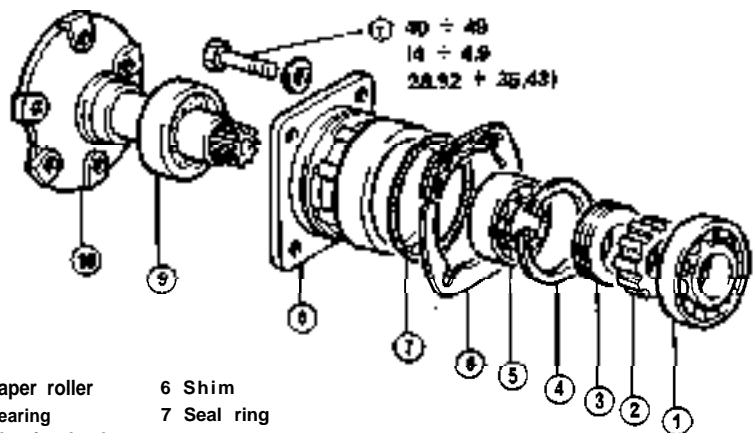

- | | |
|------------------------|-----------------------|
| 1 Taper roller bearing | 6 Shim |
| 2 Phonic wheel | 7 Seal ring |
| 3 King nut | 8 Carrier |
| 4 Lock ring | 9 Seal ring |
| 5 Ball bearing | 10 Differential shaft |

T N·m
(kg·m
ft·lb)

GEARBOX

DISASSEMBLY

IMPORTANT:

The following procedure refers to the right hand differential carrier.

Difference between left differential support and right one is only constituted by absence of phonic wheel in the left differential support

1. Loosen and remove oil sump retaining screws with relevant washers, now remove the sump and the seal gasket.

2. Loosen and remove the screws ① securing the differential carrier ② to the gearbox casing. Partially pull back the carrier and remove the two shims ③, being careful to mark the relevant position to be later followed during reassembly. Now completely disassemble differential carrier.

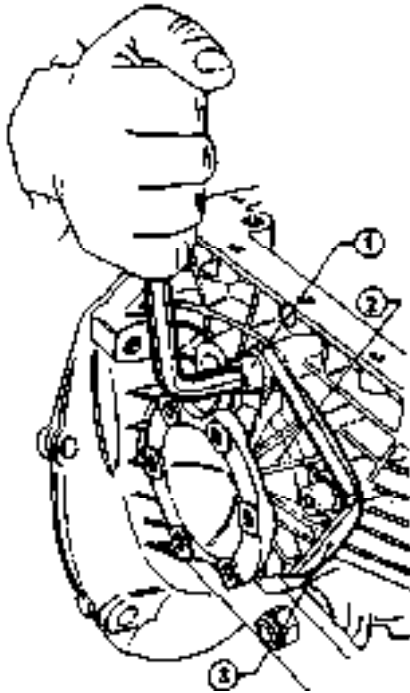

1 screw 3 Shim
2 Differential carrier

3. Remove seal ring ⑦ from

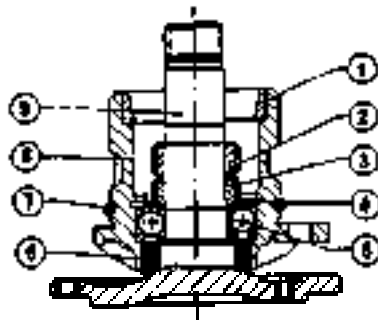

1 Taper roller bearing outer race
2 Phonic wheel
3 Ring nut
4 Spring ring
5 Bearing
6 Oil seal ring
7 Seal ring
8 Differential carrier
9 Differential shaft

4. Lock differential carrier in a vice and remove the ring nut securing the differential carrier on the bearing and phonic wheel using tool A.3.0298.

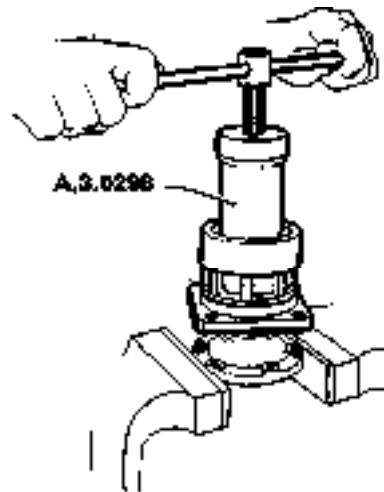

5. With the help of a press and of plates A.3.0295, remove differential shaft ① from the carrier ②. Remove the oil seal ring.

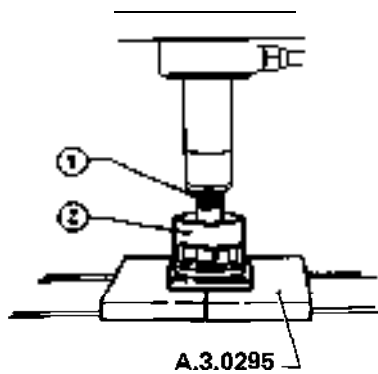

1 Differential shaft

6. Using tool A.3.0299, remove the differential carrier taper roller bearing outer race.

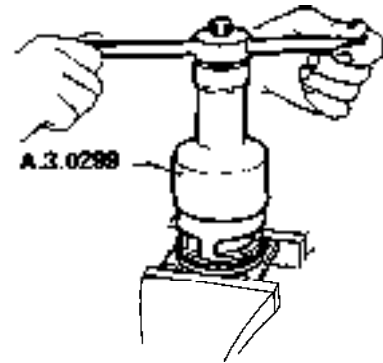

7. Remove the bearing lock ring from its seat in the differential carrier.

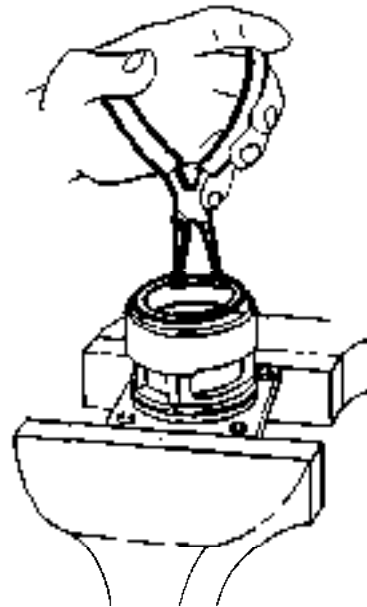

8. Now with tool A.3.0302, remove the ball bearing from the differential carrier.

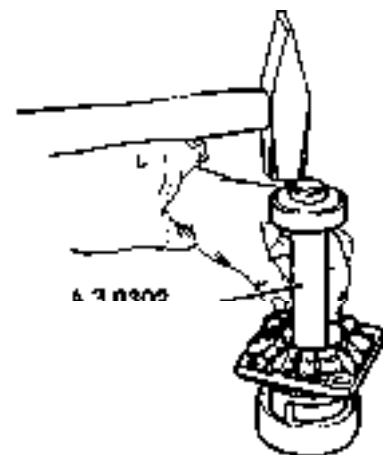

GEARBOX

Following the same procedure, disassemble the left hand differential carrier.

9. In case of malfunction of speed indicator device, remove sensor ② from gearbox after removing retaining spring ① and replace it.

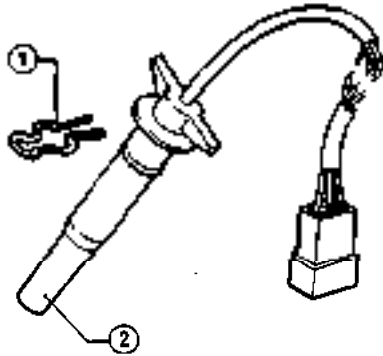

1 Spring ring 2 Sensor

CHECKS AND INSPECTIONS

Having thoroughly washed all parts, perform following checking operations:

1. Carefully inspect all bearings while slowly rotating them: no vibrations, noise or sticking should be noticed if bearings are in good working condition.

2. Check the surface of all rings and rotating parts making sure that there are no scores, marks or roughness due to friction of foreign matter.

If surfaces of rings and of rotating parts show scores, evidence of abnormal wear, pitting or overheating, replace them without hesitation.

3. Check that contact surface of differential shaft splines extends to the entire working surface; if any of the teeth is chipped or show evidence of abnormal wear, replace shafts making sure that relevant mating parts have not been damaged.

ASSEMBLY

Referring to the right hand differ-

ential carrier, proceed as follows:

1. Apply gearbox oil to the oil seal ring outer surface and fit it into its seat on the differential carrier using tool A.3.0430.

CAUTION:

Make sure the crowfoot on the oil seal ring points in the direction of the differential shaft rotation.

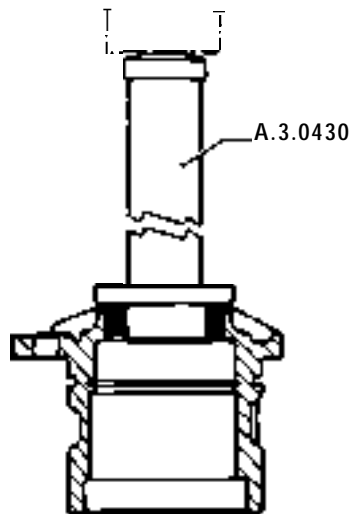

2. With tool A-3.0302 and the help of a press, fit the differential shaft bearing into the carrier.

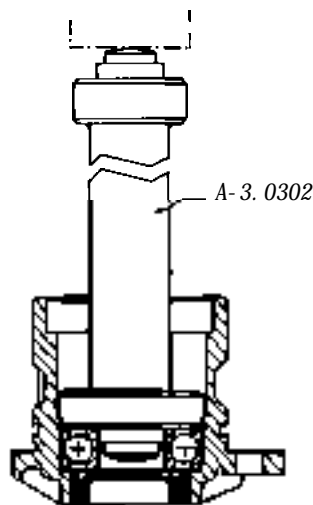

3. Fit the differential shaft bearing lock ring.

4. Using tool A-3.0292 fit the taper roller bearing outer race into the carrier.

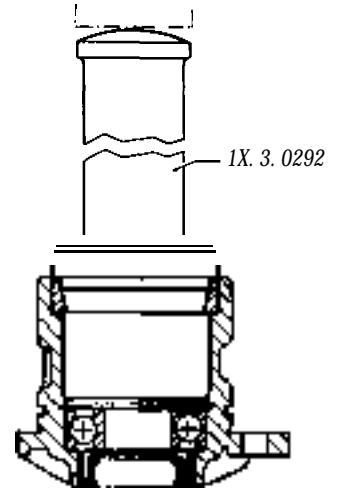

5. Apply grease (ISECO Molykote BR2) to the oil seal ring inner surface and to its seat on the differential shaft. With tool A-3.0293 and the help of a press and a rest plate, fit now the differential shaft.

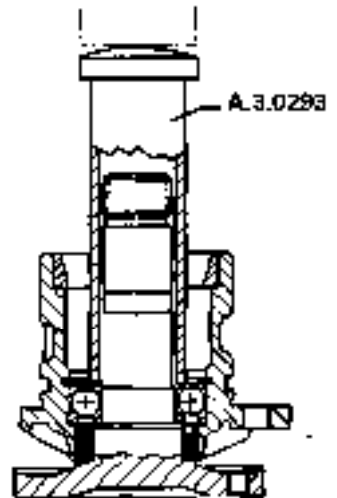

6. Apply gearbox oil (AGIPF1 Rotra MP SAE 80W90 or IP Pontiax HD80W90) to the mating surfaces on differential shaft of the bearing retaining ring nut. Make sure to fit a new ring nut.

7. On differential shaft install first ring, nut and then phonic wheel, using tool A.3.0293 together with a press and a rest plate.

8. After having applied a coating of gearbox oil, fit the small seal ring in the carrier's groove.

9. Fit the right hand differential carrier in its seat on the gearbox casing

GEARBOX

Following the same procedure, reassemble the left hand differential carrier.

10. Fit oil sump with relevant sealing gasket.

CROWN GEAR AND PINION

DISASSEMBLY

Crown gear

1. Remove differential carriers from the gearbox-differential casing (refer to: Differential Carriers - Disassembly).
2. Remove differential casing from the gearbox-differential casing (refer to: Differential casing - Disassembly).
3. Loosen and remove the screws securing the crown gear to the differential casing and then remove the crown gear.

Pinion

1. Remove gears from pinion shaft and then withdraw the shaft from its seat in the gearbox-differential casing, with relevant bearings (refer to: Shafts and Gears).

CHECKS AND INSPECTIONS

Having thoroughly washed all parts, proceed as follows:

1. Slowly rotate bearings checking them for vibrations, noise or sticking.
2. Check surface of all rotating parts and of rolling tracks for scores or any evidence of abnormal wear, pitting or overheating; in the affirmative, replace the parts involved.
3. Make sure that contact pattern of bevel pinion teeth extends to their entire working surface. If any of the teeth are nicked, replace the pinion and make sure the crown gear has not been damaged as a consequence. Check both toothings for scores and any evidence of pitting or excess wear.

ASSEMBLY

Crown gear

1. Following the procedure de-

scribed in paragraph "Differential Casing - Assembly", fit crown gear to differential casing.

2. Fit differential casing back to gearbox casing.

Pinion

Position the pinion into its seat in the gearbox-differential casing and fit bearings and gears (refer to: Shafts and Gears).

TESTING

Verify back-lash between crown gear and pinion in four diametrically opposite positions. Irregular back-lash, with excessive differences between the measured points, is an indication of crown gear deformation with consequent flatness error between gearbox casing/crown gear place and differential casing plane. Make sure the differential works properly and is completely noiseless. Incorrect assembly of crown gear and pinion or worn taper roller bearings could be the cause of the trouble.

DIFFERENTIAL CASING

DISASSEMBLY

1. Remove left and right hand differential carriers (refer to: Differential Carriers - Disassembly).
2. Remove differential casing from gearbox-casing,

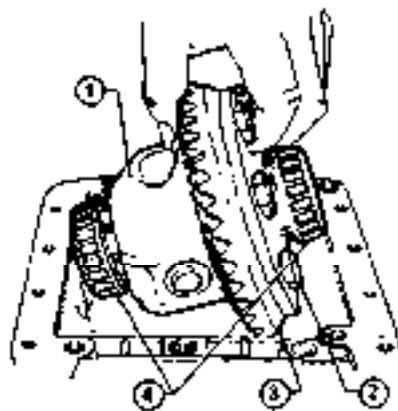

- | | |
|-----------------------|------------------------|
| 1 Differential casing | 3 Crown gear |
| 2 Retaining screw | 4 Taper roller bearing |

3. With tool A.3.0287 remove inner races of taper roller bearings from the differential casing.

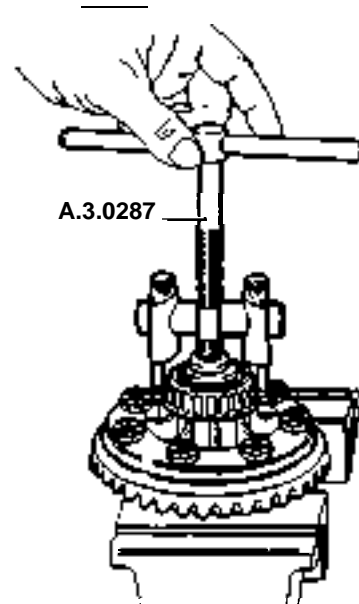

4. Loosen and remove the screws and washers securing the crown gear to the differential casing. Now remove the crown gear.

CHECKS AND INSPECTIONS

Having thoroughly washed all parts, perform the following checking operations:

1. Slowly rotate bearings checking them for vibrations, noise or sticking.
2. Check the surface of all rotating parts and of all rolling tracks for scores and any evidence of abnormal wear, pitting or overheating; in the affirmative, replace the parts involved.
3. Visually check gears, both planetary and side gears, making sure that there are no scores or evidence of pitting, that contact pattern extends to their entire working surface and further that mating is noiseless and smooth.

If necessary, replace the whole differential casing; in this case also replace taper roller bearings.

CAUTION:

Use only metric system in order to avoid confusion in computations.

5. Compute, as shown below, the average value "Hm" of the four measurements picked-up as per item 4 above and determine the thickness of "B" shims that will have to be fitted behind the crown gear side carrier for pre-loading of taper roller bearings.

$$B = Hm - 0.20$$

whereas 0.20 is correcting factor for bearing pre-loading.
Example of computation of the four picked-up measurements:

$$H_1 = 1.88 \quad H_2 = 1.94;$$

$$H_3 = 1.90 \quad H_4 = 1.96$$

$$B = Hm - 0.20 =$$

$$= \frac{1.88 + 1.94 + 1.90 + 1.96}{4} - 0.20 =$$

$$= 1.92 - 0.20 = 1.72 \text{ mm}$$

6. Considering that max. allowed tolerance is ± 0.02 mm and that shims available as spare parts have a thickness variation step of 0.05 mm select the thickness nearest to the computed value (in the above instance one would select the 1.70 mm thickness).

7. Fit selected shims behind the crown gear side carrier and tighten retaining screws to specified torque (refer to: Step 2).

Crown gear to pinion backlash

Adjust crown gear to pinion backlash following the procedure hereafter described.

1. Rotate pinion and crown gear to allow relevant bearings to settle and then use tool A.2.0243 to lock the pinion.

Properly tighten screws of tool A.2.0243 on gearbox casing.

2. Fit a centesimal dial gauge to a magnetic base and place the gauge's indicating finger on the outer edge of a crown gear tooth at right angles with the tooth's side.

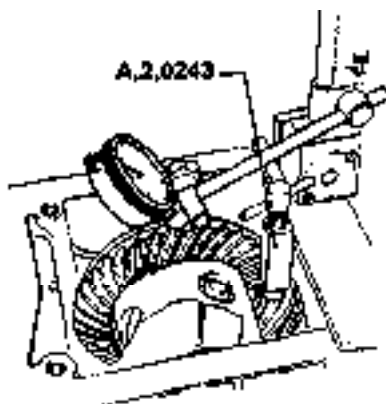

3. Rotate crown gear as far as backlash will allow and read the value shown on dial gauge.

4. Repeat the above reading on four different points of the crown gear, equally distant one from the other.

Each of the four measured values must fall within the range of 0.05 to 0.10 mm ($2 \cdot 10^{-3}$ ÷ $4 \cdot 10^{-3}$ in).

If backlash does not fall within these values, proceed as hereafter described, remembering that total shim thickness (A + B) between differential carriers and gearbox casing must remain constant otherwise it would cause bearings pre-load to change:

- in case backlash is below specified value, move crown gear away from the pinion by decreasing thickness of A shims and equally increasing that of B shims.
- in case backlash is above specified value, move crown gear closer to the pinion by increasing thickness of A shims and decreasing that of B shims by the same extent.

When correcting shim thickness it should be remembered that in order to change dial gauge reading (min. distance between crown gear and pinion teeth) by 0.01 mm ($0.4 \cdot 10^{-3}$ in), one must move a thickness of 0.015 mm ($0.59 \cdot 10^{-3}$ in) from one side to the other.

Having completed fitting of shims, tighten retaining screws to specified torque (Refer to: Adjustments - How to Determine Pre-load of Differential Casing Bearings). Double check back-

lash and if now within specified values, repeat above adjusting operations.

When refitting previously disassembled parts (carriers, differential casing, bearings and crown gear), it is essential that also same A and B shims are used - or at least new ones of same thickness - and that they are placed back exactly where they were located at time of disassembly.

GEARBOX- DIFFERENTIAL CASING

DISASSEMBLY

1. Remove rear support (Refer to: Rear Support - Disassembly).
2. Remove the clutch control fork and then withdraw the thrust bearing from the direct drive shaft (Refer to: Group 12).
3. With the help of a punch, remove the clutch control fork retaining pin.

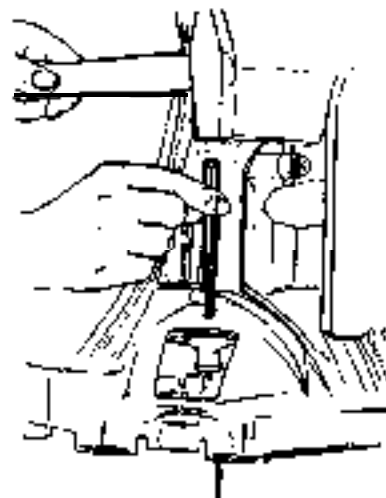

4. Remove differential carriers (Refer to: Differential Carriers - Disassembly).
5. Remove differential casing with crown gear (Refer to: Differential Casing - Disassembly).
6. Remove rods and forks (Refer to: Rods and Forks - Disassembly).
7. Remove shafts and gears (Refer to: Shafts and Gears - Disassembly).

GEARBOX

CHECKS AND INSPECTIONS

1. Thoroughly clean casing with solvent and check it for scores, nicks or evidence of pitting.
2. Check the casings mating surfaces making sure there are no nicks, no evidence of roughness nor or old sealants.
3. Check that the clutch for retaining pin is not in any way damaged.

ASSEMBLY

1. Fit shafts and gears (Refer to:

- Shafts and Gears Assembly).
2. Fit differential casing (Refer to: Differential Casing -Assembly).
3. Fit differential carriers (Refer to: Differential Carriers - Assembly).
4. Fit rods and forks. Thoroughly clean rear cover and oil sump mating surfaces; fit new gaskets with specified sealants and then fit cover and sump (Refer to: Rods and Forks - Assembly).

5. Fit clutch control fork retaining pin.

6. Fit the clutch control fork and

then fit thrust bearing on direct drive shaft (Refer to: Group 12).

7. Fit rear support (Refer to: Rear Support - Assembly).

GEARBOX OUTER LINKAGE

DISASSEMBLY

1. Loosen and remove the nut with washer (4) as well as the screw (7) securing the main selector rod (6) to the gearbox lever (1); then remove the spacer (2) and the two bushings (3).

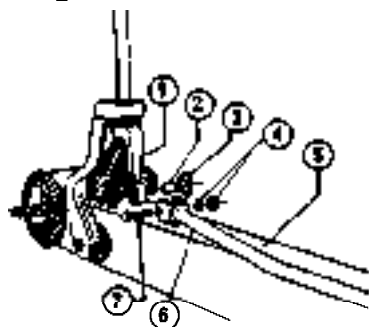

- | | |
|-------------------|---------------------|
| 1 Gearbox lever | 5 Rear support |
| 2 Spacer | 6 Main selector rod |
| 3 Bushing | 7 Retaining screw |
| 4 Nut with washer | |

2. Loosen and remove the gearbox lever guide (4) retaining screws with washers (2); now remove the guide, the boot (1) and the bushing (3) located at lever's end.

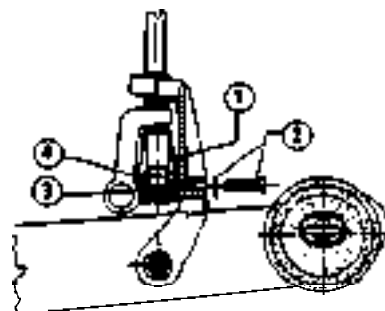

- | | |
|-----------------------|-----------|
| 1 Boot | 3 Bushing |
| 2 Screws with washers | 4 Guide |

3. Loosen and remove the nut (2) and the screw (7) securing the gearbox lever support (1) to the flexible bush (4) located on the rear extensions; now remove side washers (3) as well as the spacer (5).

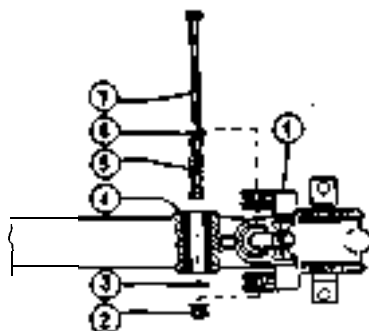

- | | |
|-----------------|----------|
| 1 Support | 5 Spacer |
| 2 Nut | 6 Washer |
| 3 Washer | 7 Screw |
| 4 Flexible bush | |

4. Remove rear support (Refer to: 5-Speed Manual Gearbox - Rear Support).

6. Lastly remove the flexible bush with the help of following tools: a press, a plate, a base and punch tool.

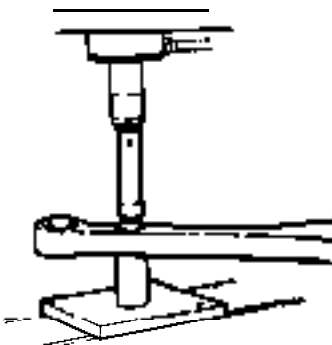

CHECKS AND INSPECTIONS

1. Thoroughly clean outer linkage metal parts with solvent and make sure they are in good condition.
2. Check linkage articulated joints for excess wear.
3. Make sure boot is in perfect condition; if damaged or worn, replace it.

ASSEMBLY

1. Fit rear support (Refer to: 5-Speed Manual Gearbox - Rear Support).

2. Apply grease (AGIPF1 Grease 15 or SHELL Retinax G) to the spacer (1) on the speed selector lever to main selector rod connection (4) and to the spacer (3) securing the fork to the flexible bush on the gearbox cover.

Apply 5 g (0.176 oz) of same grease to the speed selector lever guide (2).

3. Go on to fit all gearbox outer linkage following disassembly procedure in reverse sequence.

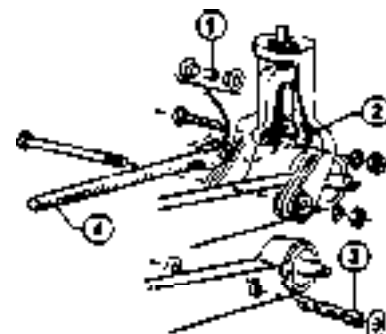

- | | |
|----------|---------------------|
| 1 Spacer | 3 Spacer |
| 2 Guide | 4 Main selector rod |

SERVICE DATA AND SPECIFICATIONS

TECHNICAL DATA

Gearbox differential	Speed selector lever positions	Speed	Gearbox ratio	Differential ratio			
				9/35		11/39	
				Gearbox-differential overall ratio	Speed at 1000 r.p.m. Km/h (mi/h)	Gearbox-differential overall ratio	Speed at 1000 r.p.m. Km/h (mi/h)
		1 2 3 4 5 R.G.	1 : 3.750 1 : 2.050 1 : 1.387 1 : 1.027 1 : 0.825 1 : 3.091	1 : 14,580 1 : 7,970 1 : 5,392 1 : 3,992 1 : 3,207 1 : 12,017	7.08 (4.39) 12.96 (8.05) 19.15 (11.89) 25.87 (16.07) 32.20 (20.0) 8.59 (5.34)	1 : 13.293 1 : 7.267 1 : 4.916 1 : 3.640 1 : 2.924 1 : 10.957	7.77 (4.81) 14.21 (8.81) 21.01 (13.05) 28.37 (17.63) 35.23 (21.89) 9.42 (5.86)
Engine		1200 1350 1500		1200 1350		1500	

GENERAL SPECIFICATIONS

FLUIDS AND LUBRICANTS

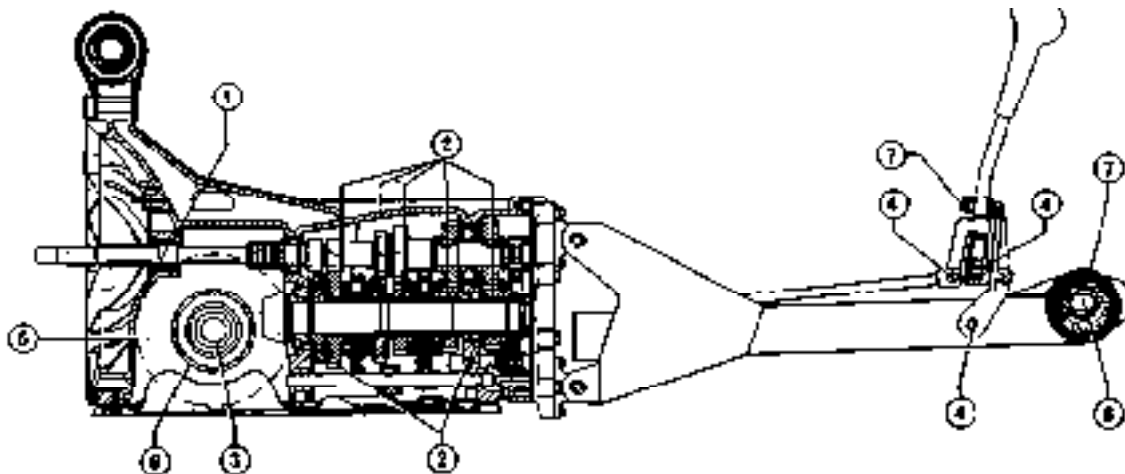

App. no.	Application	Type	Name	Qty
1	Inner surface of: - Seal ring of main selector rod - Seal ring of primary shaft - Seal ring of differential shaft - Seal lip and work seat on shaft	GREASE	ISECO Molykote BR2 Std. No. 367159941	—
	Outer surface of: - Seal rings	OIL	See item 5	—

GEARBOX

App. "0.	Application	Type	Name	Q.ty
2	Outer races of differential casing and pinion taper roller bearings	GREASE	— AGIP: F1 Grease33 FD Std. No. 3671 69833	
3	Mating surfaces of: — Ring nut securing bearing to differential shaft	OIL	See item 5	—
4	Outer surface of: — Spacer on main selector rod to speed selector lever connection — Spacer for lever to fork fitting Speed selector lever guide	GREASE	— AGIP: F1 Grease 15 — SHELL: Retinax G Std. No. 3671-69811	5 g (0.176 oz)
5	Fill-up of gearbox-differential casing	OIL	— AGIP: F1 Rotra MP SAE 80W90 — IP: Pontiax HD 80W90 Std. No. 363169408	2,300 kg +0,100 kg 5.07 lb + 0.22 lb)
6	Outer surface of differential carriers and relevant seats on gearbox casing Bushings for bevel pinion driven gears	OIL	See item 5	—
7	Outer surface of: — Gearbox rear flexible support — Flexible support for speed selector lever upper joint	GREASE	— UNION CARBIDE CHEMICAL COMPANY: Ucon lubricant 50 HE-5100 — MI LLOIL: slipping agent for rubber sections Std. No. 4500-I 7502	—
8	Outer surface of: — Fin for gearbox rear flexible support	GREASE	— SPCA: spagraph — ISECO: Ergon Rubber Grease no. 3 Std. No. 367169816	—

SEALANTS AND SURFACE-FIXING AGENTS

Application	Type	Name	Q.ty
Lower screws securing differential carriers to gearbox casing	CEMENT	DOW CORNING: Silastic RTV732 Std. No. 3522-00040	

GEARBOX

Application	Type	Name	Q.ty
— Screws securing forks to speed selector rods N.B. For surface cleaning use:	CEMENT	Omnifit 150 H Std. No. 352400023	—
	SURFACE FIXING AGENT	Omnifit — Std. No. 3514-90003	
— Inner surface of bore for oil plug on gearbox casing	CEMENT	DIRING: Heldite Std. No. 3522-00015	—

INSPECTION AND ADJUSTMENT

REAR SUPPORT

“β” positioning of gearbox rear flexible support

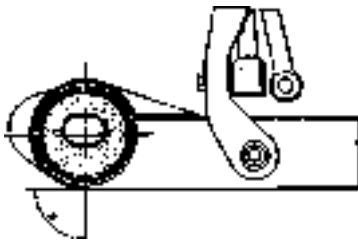

β	degree	90 ± 2
---	--------	--------

RODS AND FORKS

1. “S” clearance between 3rd-4th speed rod ② and 1st-2nd speed selector lever ①

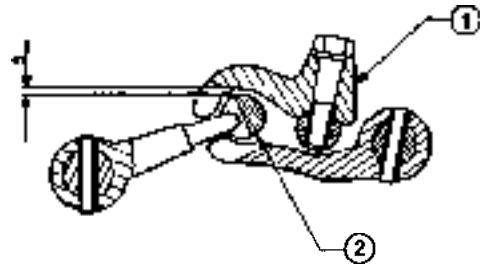

S	mm (in)	1.4 ÷ 1.9 (5.5 · 10 ⁻² ÷ 7.4 · 10 ⁻²)
---	------------	-----------------------------------------------------------------

2. End play between fork and synchronising unit sleeves

Clearance	mm (in)	0.250 ÷ 0.375 (9.8 · 10 ⁻³ ÷ 1.5 · 10 ⁻²)
-----------	------------	---------------------------------------------------------------------

ROLLING TORQUES

Item	N·dm	kg·dm	ft·lb
Dummy pinion			
— Original bearings being used again	3 ÷ 6	0.3 ÷ 0.6	0.217 ÷ 0.434
— Replacement bearings (new)	12 ÷ 15	1.2 ÷ 1.5	0.867 ÷ 1.085
Pinion with gear train			
— Original bearings being used again	4 ± 7	0.4 ÷ 0.7	0.289 ÷ 0.506
— Replacement bearings (new)	13 - 16	1.3 ÷ 1.6	0.939 ÷ 1.157

GEARBOX

DIFFERENTIAL CASING

Thickness "S" of shims B for pre-loading of differential casing taper roller bearings

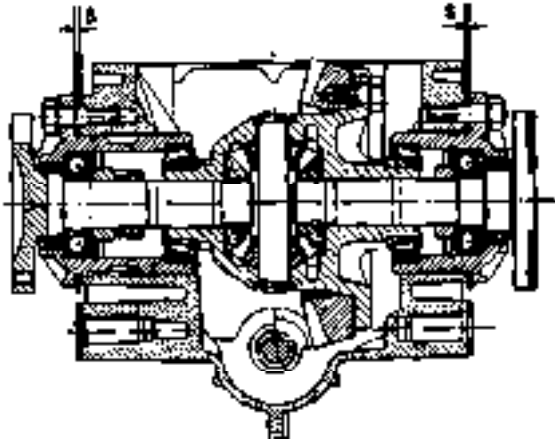

$$S = H \text{ (avg.)} - 0.20$$

H = clearance between gearbox casing and flange of L.H. differential carrier

0.20 = corrective value for bearing preloading

Thickness mm (in)		Part No.	
1.00 (0.04)	1.55 (0.062)	101452	101463
1.05 (0.042)	1.60 (0.064)	101453	101464
1.10 (0.044)	1.65 (0.066)	101454	101465
1.15 (0.046)	1.70 (0.068)	101455	101466
1.20 (0.048)	1.75 (0.07)	101456	101467
1.25 (0.05)	1.80 (0.072)	101457	101468
1.30 (0.052)	1.85 (0.074)	101458	101469
1.35 (0.054)	1.90 (0.076)	101459	101470
1.40 (0.056)	1.95 (0.078)	101460	101471
1.45 (0.058)	2.00 (0.08)	101461	101472
1.50 (0.06)		101462	

PINION

1. Thickness "S" of shims for setting of pinion height

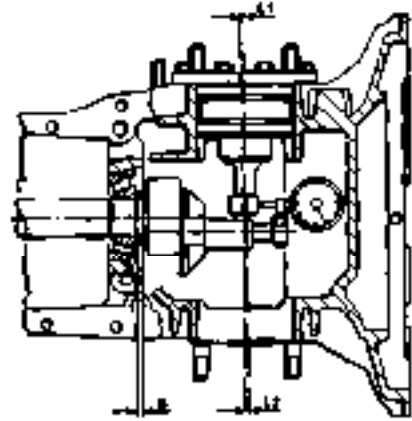

$$s = \frac{L_1 + L_2}{2} - (\pm C)$$

C = value engraved on pinion

L₁, L₂ = crown gear shaft deviation values

Thickness mm (in)		Part No.
0.75 (0.03)		101430
0.80 (0.032)		101431
0.85 (0.034)		101432
0.90 (0.036)		101433
0.95 (0.038)		101434
1.00 (0.04)		101435
1.05 (0.042)		101436
1.10 (0.044)		101437
1.15 (0.046)		101438
1.20 (0.048)		101439
1.25 (0.051)		101440

GEARBOX

2. Thickness "S" of shims for pre-loading of pinion taper roller bearings

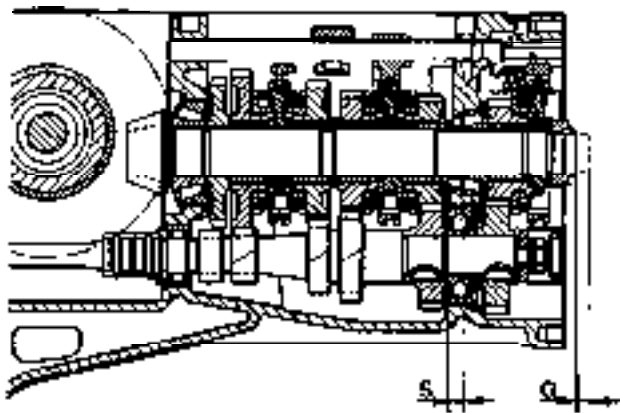

$$S = 9.60 - G - 0.10$$

9.60 = sample washer thickness

G = clearance measured by gauge

0.10 = corrective value

3. Pinion to crown gear backlash



Backlash mm 0.05 ÷ 0.10
 (in) (2·10⁻³ ÷ 4·10⁻³)

Thickness mm (in)	Part No.
4.10 (0.164)	700165
4.15 (0.166)	700166
4.26 (0.170)	700167
4.35 (0.174)	700168
4.45 (0.178)	700169
4.55 (0.182)	700170
4.65 (0.186)	700171
4.75 (0.190)	700172
4.80 (0.192)	700173

TIGHTENING TORQUES

Item	Unit	N·m	kg-m	ft-lb
LEVER AND FORKS				
Screw securing 1st - 2nd speed selector to rod		25 ÷ 26	2.5 ÷ 2.7	18.07 ÷ 19.52
Screws securing forks to speed control rods		21 ÷ 23	2.1 ÷ 2.3	15.10 ÷ 16.63
Screws securing pin for R.G. sliding gear		19 ÷ 24	1.9 ÷ 2.4	13.74 ÷ 17.36
SHAFTS AND GEARS				
Primary shaft outer bearing retaining screw		69 ÷ 85	7 ÷ 8.7	50.61 ÷ 62.91
Bevel pinion gear train retaining ring nut		220 f 245	22.5 ÷ 25	162.70 ÷ 180.77

GEARBOX

Trouble	Probable cause	Corrective action
Noisy both during acceleration and deceleration (drive shaft assy already checked)	<ul style="list-style-type: none"> • Differential gears are worn or damaged • Excess play of hypoid gears • Crown gear securing screws are loose • Bevel pinion shim is worn or damaged • Pinion shaft retaining nut is loose • Excess play in gear train 	<p>Replace gears</p> <p>Check and replace, if necessary Tighten</p> <p>Replace shim</p> <p>Check gearbox components and then tighten the nut</p> <p>Adjust gear train</p>
Transmission is noisy when in curve, both with speed engaged or when in neutral (drive shaft assy already checked)	<ul style="list-style-type: none"> • Teeth of planetary and side gears are worn, damaged or show evidence of pitting 	<p>Replace differential casing</p>
Transmission is noisy when in neutral (vehicle is not moving)	<ul style="list-style-type: none"> • Irregular variations of driving torque • Not enough oil 	<p>Adjust engine idling</p> <p>Fill up to correct level</p>
Transmission is noisy when in reverse gear	<ul style="list-style-type: none"> • Reverse gears are worn or damaged 	<p>Replace defective parts</p>
Engagement/disengagement of speed is not easy	<p>First of all it should be established if the trouble is caused by the gearbox or by the control system. If the clutch still transmits torque when the pedal is pushed-down, it means that it is not disengaged. Verify if the clutch properly couples (pedal is released) and uncouples (pedal is pushed-down) the engine to the gearbox casing. If clutch is not faulty, the trouble originates either from the gearbox or from the control system.</p> <ul style="list-style-type: none"> • Bushing on outer speed selector lever is worn • Gearbox outer linkage needs adjusting and/or lubrication of joints is insufficient • Stroke of outer linkage parts is not sufficient due to excess play • Not enough oil in gearbox-differential casing • Synchronizing units are faulty • Inner controls are deformed or worn 	<p>Replace bushing</p> <p>Check linkage, joints and controls</p> <p>Check the system and, if necessary, repair or replace worn parts</p> <p>Fill-up to correct level</p> <p>Refer to "Synchronizing unit is faulty"</p> <p>Repair or replace defective parts</p>
Speeds become disengaged	<ul style="list-style-type: none"> • Sleeves and gears are worn or defective • Excess end-play of the gear that becomes disengaged (Noisy both during acceleration and deceleration) 	<p>Replace worn parts</p> <p>Verify adjustment of gear train</p>

GEARBOX

Trouble	Probable cause	Corrective action
Speed selection is poor	<ul style="list-style-type: none"> • Bushing on outer speed selector lever is worn • Plungers are worn or damaged • Springs can no longer be used due to fatigue or because they are broken • Rod millings are worn or deformed • Selector fork and/or levers are worn or damaged 	Replace bushing Replace plungers Replace springs Replace rods Replace the selector and/or the levers
Synchronizing unit is faulty or grinds	<ul style="list-style-type: none"> • Sleeve and gear front tothing are worn or damaged • Distance between gear and sleeve front tothing is incorrect • Synchronizing ring is worn • Sleeve splines are worn or damaged 	Replace defective parts Replace defective parts Replace Replace
Reverse gear light do not light up when R.G. is engaged	<ul style="list-style-type: none"> • Switch of R.G. light is faulty 	Replace the switch
Speed selector lever vibrates and is noisy	<ul style="list-style-type: none"> • Lever return spring is out of order due to fatigue • Bushing on outer speed selector lever is faulty • Refer to other items concerning noisy gearbox 	Replace faulty parts
Seizure, pitting or breakage	<ul style="list-style-type: none"> • Oil level is below normal or oil is not of the specified type • Incorrect clearances (not enough) • Bearing and gear adjustments are incorrect • Excessive torque or improper use of clutch • Retaining screws are loose 	Replace faulty parts and use specified oil Adjust clearances and replace faulty parts Replace faulty parts Replace faulty parts and tighten screws to specified torque







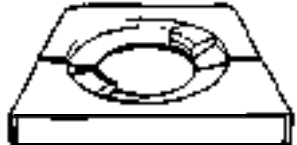

SPECIAL SERVICE TOOLS

Tool number	Tool name	Refer to page
 A.2.0234	Spacer for locking of intermediate flange (to be used with A.2.0242)	13-18



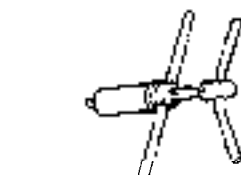

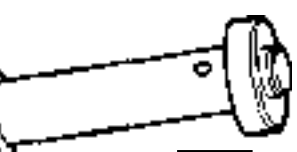

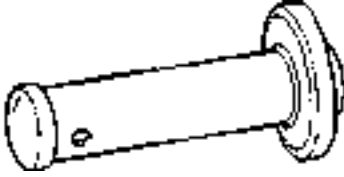

GEARBOX

Tool number	Tool name	Refer to page
A.2.0242	Support of dial gauge to read pinion spacer thickness (to be used with A.2.0234)	13-18
A.2.0243	Tool for locking pinion	13-24
A.2.0274	Adapter of sheave for checking pinion bearing pm-load	13-16 13-18
A.2.0300	Tool for locking mainshaft (to be used with A.3.0300)	13-12 13-14 13-15
A.3.0287	Adjustable span puller for differential carrier bearing cones	13-22
A-3.0291	Puller of bush shim and oil seal from mainshaft and gearshift rod	13-12
A-3.0292	Driver of differential bearing cups	13-21
A.3.0293	Driver of bearing and phonic wheel retainer onto differential spindle	13-21
A.3.0294	Driver of oil seal onto gear shift rod (with assembled unit)	13-10

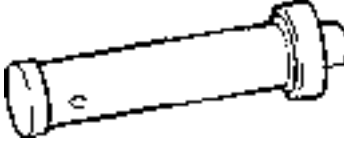
GEARBOX

Tool number	Tool name	Refer to page
A.3.0295	Plate for whith drawal of differential spindle 	13-20
A.3.0296	Puller / driver of rear pinion bearing cup and puller of pinion shaft and mainshaft 	13-11 13-13 13-14 13-15
A.3.0297	Puller / driver of front pinion bearing cup (use with A.3.0296) 	13-11 13-15
A.3.0298	Puller of speedometer pinion and ring nut from shaft 	13-20
A.3.0299	Puller of differential bearing outer races 	13-20
A.3.0300	Driver of mainshaft and 5th speed driver gear 	13-15 13-16
A.3.0301	Driver of pinion 	13-16
A.3.0302	Puller / driver of drive flange bearing 	13-20 13-21
A.3.0303	Guide for fitting striking rod balls of 3rd. 4th and rev. striking rods (use with A.3.0309) 	13-8 13-9

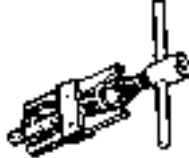
GEARBOX

Tool number	Tool name	Refer to page
A.3.0430	Driver of output shaft seal 	13-21
A.3.0452	Puller of drive spindle seal (with unit assembled) 	13-12
A.3.0453	Driver of drive spindle seal 	13-19
A.3.0490	Puller of 4th - speed gear from mainshaft (to be used with A.3.0296 and A.3.0492) 	13-73 13-14
A.3.0491	Puller / driver of rear mainshaft bearing (to be used with A.3.0296) 	13-14
A.39492	Auxiliary shaft for removing 4th-speed gear from mainshaft [to be used with A.3.0296 and A.3.0490] 	13-13
A.3.0495	Puller of 5th - speed drive gear 	13-13
A.3.0500	Tool for removing rear mainshaft bearing (to be used with A.3.0296 and A.3.0491) 	13-14
A.4.0136	Support of dial gauge for pinion setting (to be used with C-6.01 61) 	13-17

GEARBOX

Tool number	Tool name	Refer to page
C.5.0124	<p>Sheave for checking differential bearing pm-load (to be used with A.2.0274 and C.2.0037/.....)</p>	<p>13-16 13-17 13-18</p>
C.6.0161	<p>Reference gauge for pinion setting (to be used with A.4.0136)</p>	<p>13-17</p>
C.6.0162	<p>Tool for checking pinion setting (to be used with A.4.0136)</p>	<p>13-17</p>

DIFFERENTIAL AND DRIVE SHAFT ASSEMBLY

GROUP 17

CONTENTS

DIFFERENTIAL	17-2	Installation	17-5
Crown gear and pinion	17-2	SERVICE DATA AND	
Differential casing	17-2	SPECIFICATIONS	17-6
DRIVE SHAFT ASSEMBLY	17-2	General specifications	17-6
Removal	17-3	Tightening torques	17-6
Disassembly	17-3	TROUBLE DIAGNOSIS AND	
Checks and inspections	17-4	CORRECTIONS	17-6
Assembly	17-4	SPECIAL SERVICE TOOLS	17-6



DIFFERENTIAL

CROWN GEAR AND PINION

For crown gear and pinion overhauling procedure refer to: Group 13 -5-Speed Manual Gearbox - Crown Gear and Pinion.

DIFFERENTIAL CASING

For differential casing overhauling procedure refer to: Group 13 5-Speed Manual Gearbox Differential Casing.

DRIVE SHAFT ASSEMBLY

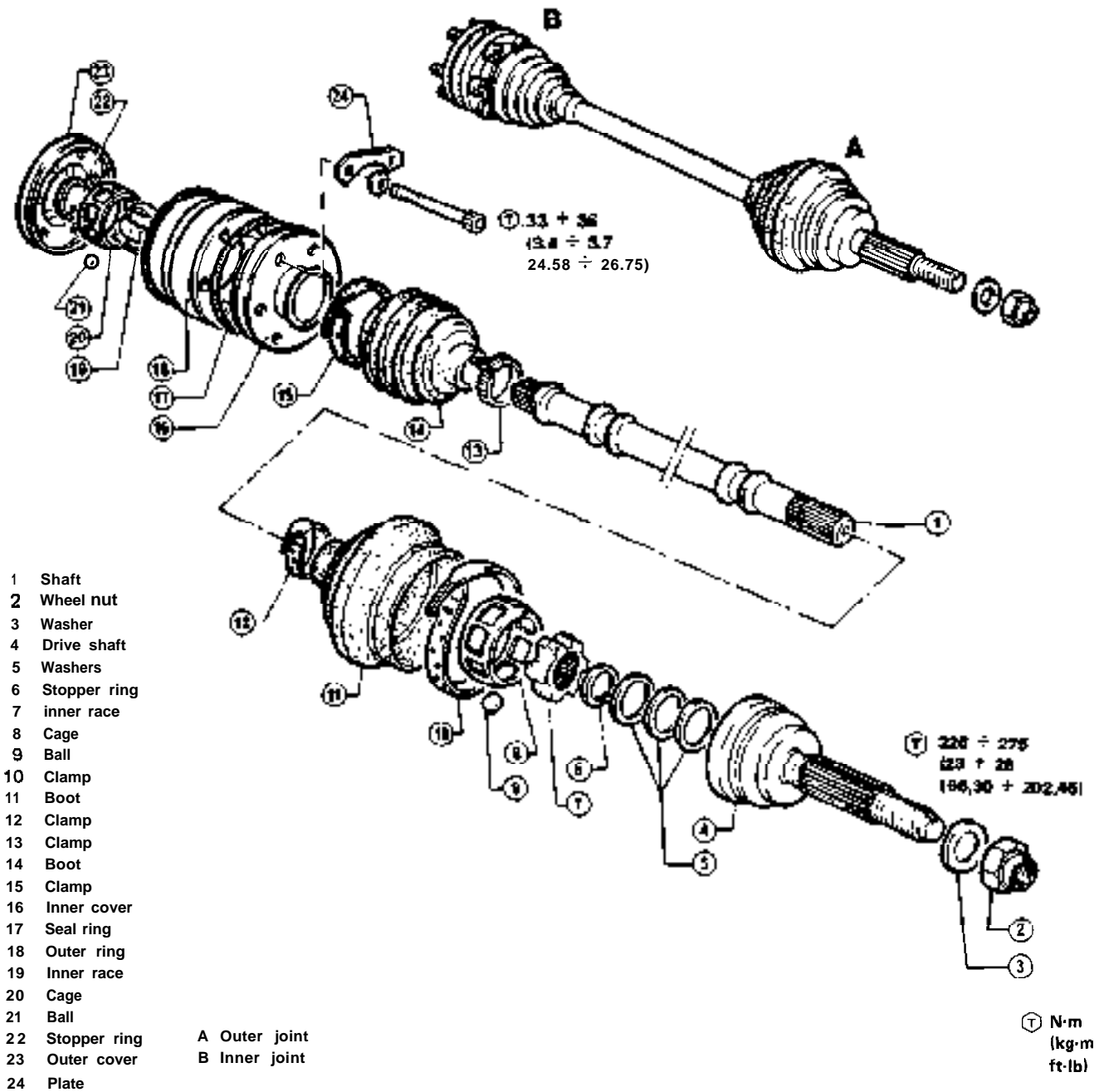

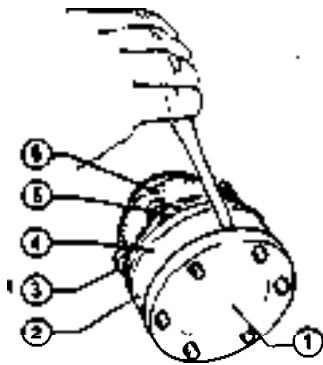

- 1 Outer cover
- 2 Outer ring
- 3 Plates retaining screws
- 4 Inner cover
- 5 Plate
- 6 Boot

5. Mark outer ring, cage and joints inner race with a reference line to ensure proper positioning when assembling.

6. Use pliers to remove lock ring.

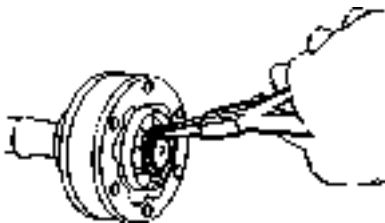

7. Now remove the constant-speed joint from the shaft with the help of a press, two half-plates, a punch and a base.

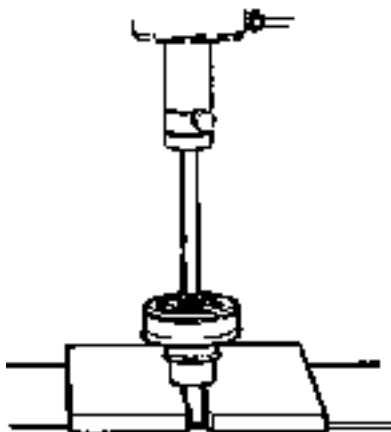

8. Slip boot off the shaft and remove inner cover from the joint.

9. Remove both seal rings from the joint's outer ring.

10. Remove steel balls from the joint and then disassemble the joint into its different components: outer ring (3), cage (2), and inner race (1).

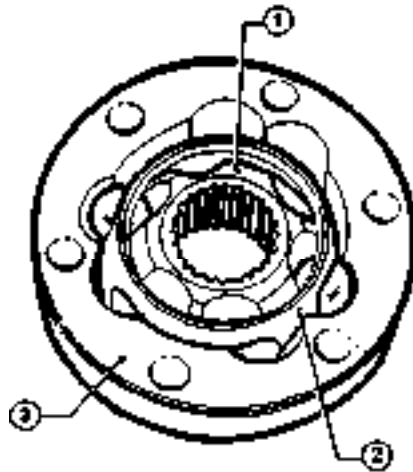

- 1 Inner race
- 2 Cage
- 3 Outer ring



CHECKS AND INSPECTIONS

1. Using suitable equipment, thoroughly clean all joint parts.

2. Check working surfaces and balls for scores or any evidence of wear due to friction of foreign matter; replace the joint, if necessary. Remember that broken boots will cause loss of lubricant and will also allow foreign matter to enter which, in turn, will cause faulty operation of the constant-speed joints; usually this problem is easily detected during testing.

3. Make sure that play in both joints is not too much since excessive play is the cause of noise during sudden torque reversal; this is evidenced by a knocking sound which is easily detected during testing.

Should disassembly be required, it is advisable to replace the joint protecting boots as well as the seal rings on the constant-speed joint on gearbox-differential side.

ASSEMBLY

Reassemble joints being careful to fit parts back into their original position, as marked at time of disassembly, and following the procedure hereafter described.

OUTER JOINT (A)

1. Thoroughly coat with grease (Molykote VN 2461 C or Optimol Olistamoly 2 L N 584) the cage, the inner race and the steel balls; pack the joint's recess with 40 g (1.41 oz) of the same type grease.

2. Fit boot on shaft being extremely careful not to damage it in any way along the splines; to this effect splines should be covered with tape.

3. Fit lock ring to groove on joint's inner race. Make sure lock ring is properly and securely lodged in its seat on the shaft.

4. Following disassembly procedure in reverse sequence, now fit the inner race and the cage.

Inner race should be fitted so that its face, on which lock ring was previously fitted, faces to outside of the joint.

5. Fit steel balls as shown in the figure.

CAUTION:

Do not exchange this joint's steel balls with those of the inner joint as their diameter is different.

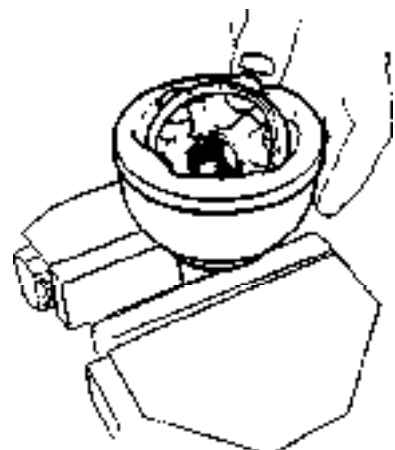

6. Fit washers on shaft, wheel side, according to numbering marked at time of disassembly. Now fit the constant-speed joint with the help of a press, of two half-plates and of tool A.3.0605.

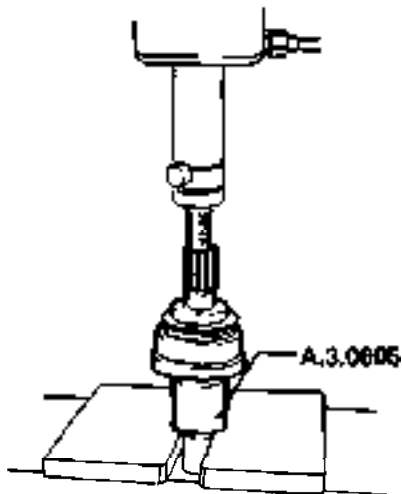

7. Finish up lubricating by packing joint with 40 g (1.41 oz) more of the above mentioned grease and make sure that balls are completely surrounded by grease.

8. Fit boot on joint; fit new clamps and tighten them using suitable pliers being careful not to damage the boot in doing so.

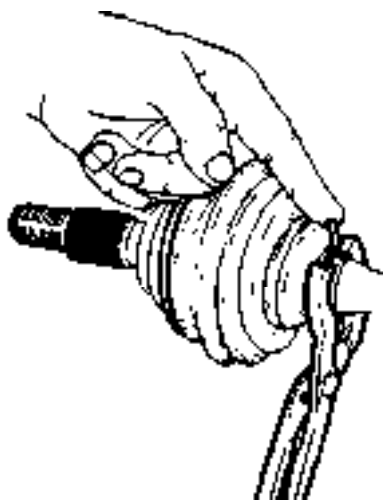

INNER JOINT (B)

Thoroughly coat with grease (Molykote 2461 C or Optimal Olistamoly 2 L N 584) the cage, the inner race and the steel balls; pack the joint's recess with 40 g (1.41 oz) of the same type grease.

1. Fit boot on shaft being extremely careful not to damage it in any

way along the splines; to this effect splines should be covered with tape.

2. Following disassembly procedure in reverse sequence, now fit the inner race and the cage.

3. Fit steel balls as shown in the figure and verify that the joint works properly.



CAUTION:

Do not exchange this joint's steel balls with those of the outer joint as their diameter is different.

4. Fit inner cover to the joint and then fit the latter on the shaft with the help of a press, of two half-plates, of a base and a punch.

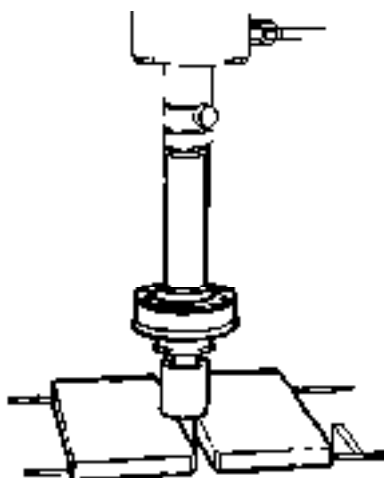

5. Pack joint with 40 g (1.41 oz) more of the above mentioned grease and make sure that balls are completely surrounded by grease.

6. Fit both seal rings on the joint's outer ring.

7. Fit lock ring following disassembly procedure in reverse sequence.

8. Fit the boot; fit new clamps and tighten them using suitable pliers being careful not to damage the boot in doing so.

9. Fit the three plates to the inner cover, insert relevant screws and washers, and lastly fit the outer cover onto the six screws.

INSTALLATION

1. Insert shaft into wheel hub.
2. Connect shaft to differential drive shaft and lock securing screws to specified torque.

T: Tightening torque
33 ÷ 36 N·m
(3.4 ÷ 3.7 kg·m
24.56 ÷ 26.75 ft·lb)



3. By means of a new nut, secure wheel hub to shaft. Tighten nut to specified torque, then caulk it.

T: Tightening torque
226 ÷ 275 N·m
(23 ÷ 28 kg·m
166.30 ÷ 202.46 ft·lb)

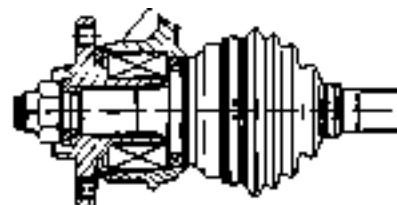

SERVICE DATA AND SPECIFICATIONS

GENERAL SPECIFICATIONS

FLUIDS AND LUBRICANTS

Application	Type	Denomination	Q.ty
Drive shaft assembly constant-speed joints (for each joint)	GREASE	Molykote VN 2461 C or Optimal Olistamoly 2 LN 584 Std. No. 3671-69843	80 g (2.82 oz)
Split grease quantity between the two sides of each joint's crown of steel balls			

TIGHTENING TORQUES

Item	Unit	N·m	kg·m	ft·lb
Screws securing (in oil), with outer spacer, drive shaft assembly to differential shaft		33 ÷ 36	3.4 ÷ 3.7	24.58 ÷ 26.75
Nuts securing drive shaft assembly to wheel hub		226 ÷ 275	23 ÷ 28	166.30 ÷ 202.46

TROUBLE DIAGNOSIS AND CORRECTIONS

Condition	Probable cause	Corrective action
Nocking during sudden torque reversal	<ul style="list-style-type: none"> Too much play between seats and steel balls Not enough lubricating grease and leakage from the boots 	Replace the joint Smear with grease and replace boots

SPECIAL SERVICE TOOLS

Tool number	Tool name	Refer to page
A.3.0605	Base for withdrawal and fitment of drive shaft from constant speed joint.	 17-3 17-5

FRONT SUSPENSION

GROUP 21

CONTENTS

DESCRIPTION	21-2	SERVICE DATA AND	
FRONT WHEELS HUB	21-3	SPECIFICATIONS	21-9
Removal	21-4	Technical data	21-9
Disassembly	21-4	General specifications	21-10
Checks and inspections	21-5	Checks and inspections	21-10
Assembly	21-5	Tightening torques	21-11
Installation	21-6	TRUBLE DIAGNOSIS AND	
FRONT SUSPENSION	21-6	CORRECTIONS	21-11
Coil spring and shock absorber	21-6	SPECIAL SERVICE TOOLS	21-13
Transverse and semi-trailing link ...	21-8		

Refer to Group 00 - Chassis and Body Maintenance
for:

- Checking Suspension Height
- Wheel Alignment

DESCRIPTION

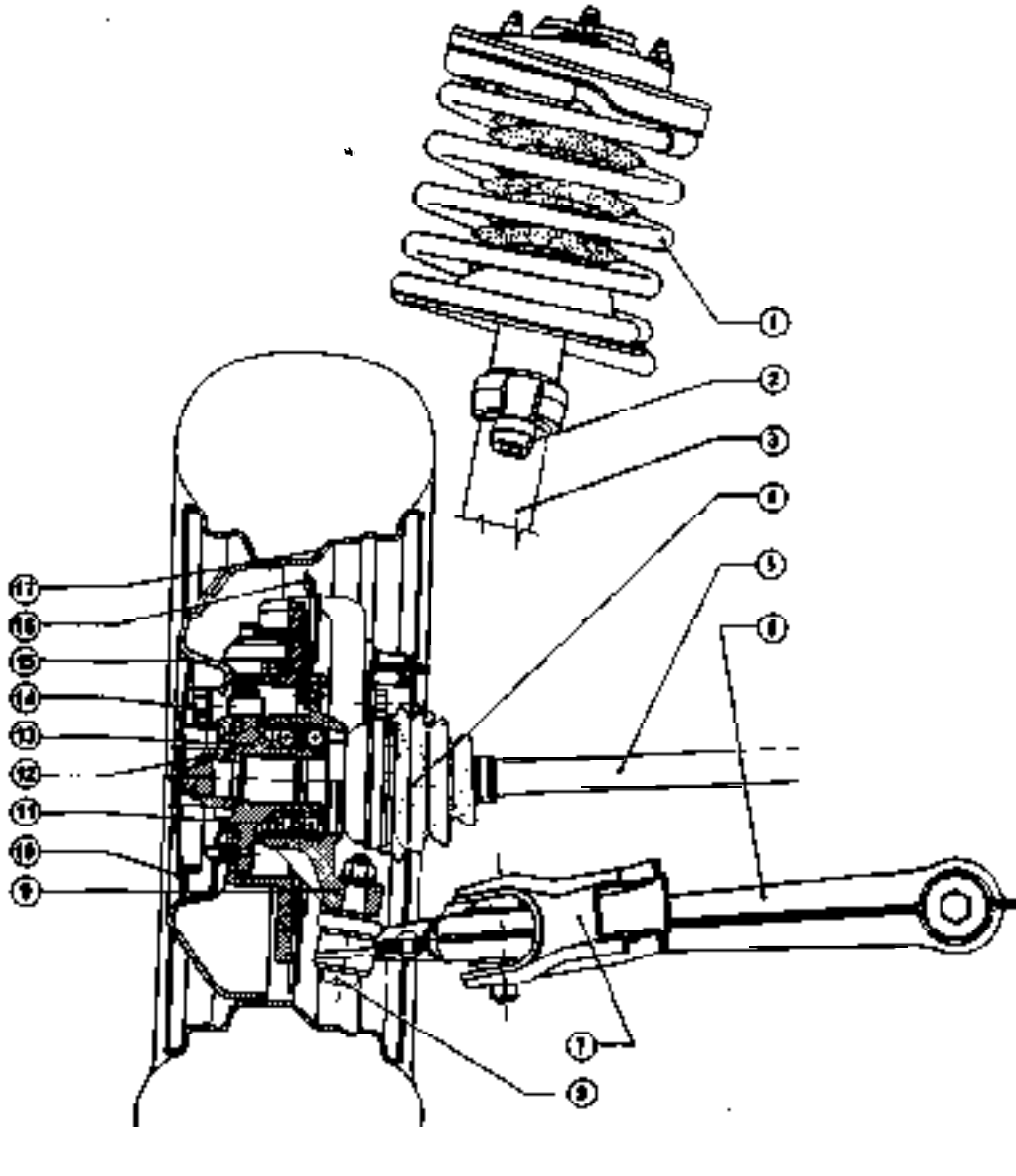

- | | |
|----------------------|----------------|
| 1 Coil spring | 10 Wheel cover |
| 2 Steering lever | 11 Bearing |
| 3 Strut | 12 Hub nut |
| 4 Joint boot | 13 Wheel hub |
| 5 Shaft | 14 Wheel screw |
| 6 Semi-trailing link | 15 Brake disc |
| 7 Transverse link | 16 Dust cover |
| 8 Ball joint | 17 Rim |
| 9 Hub support | |

REMOVAL

1. Place the car on lift, block rear wheels and lift the front by means of a jack, then support it on stands sited in adjacent position to the bearing points (refer to: Group 00 - Lifting Points and Towing).
2. Remove wheel from the operative side.
3. Remove the nut caulking (4) and unscrew it out of drive shaft (3) end.
4. Remove drive shaft from differential shaft by unscrewing the six securing screws. Remove shaft with the two constant-speed joints.
5. Detach caliper (2) from hub support, without disconnecting it from hose (1).

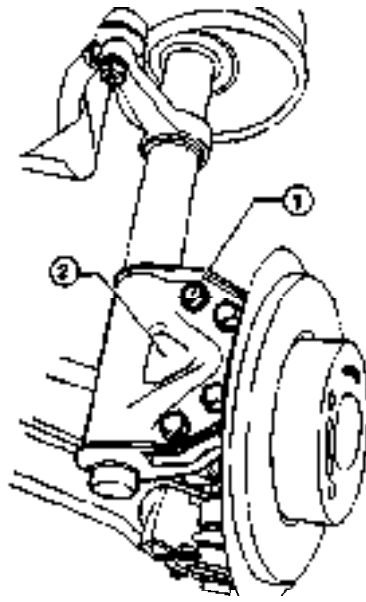

1 Screws 2 Bracket

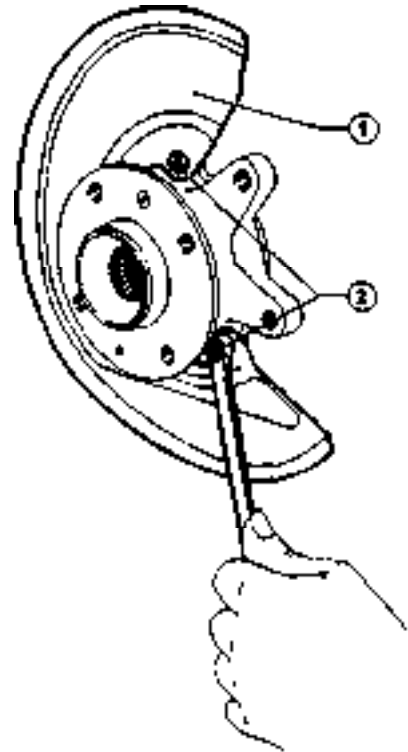

1 Dust cover
2 Dust cover securing screws

7. Unscrew and remove nut securing ball joint pin (1), on semi-trailing link (2), to hub support. Hold hub support properly, and by using the A.3.0157 withdraw pin.

2. Using a screwdriver withdraw seal ring from hub support (shaft side).

3. Withdraw hub (1) from its support (2) by means of a press, a suitable punch and two plates.

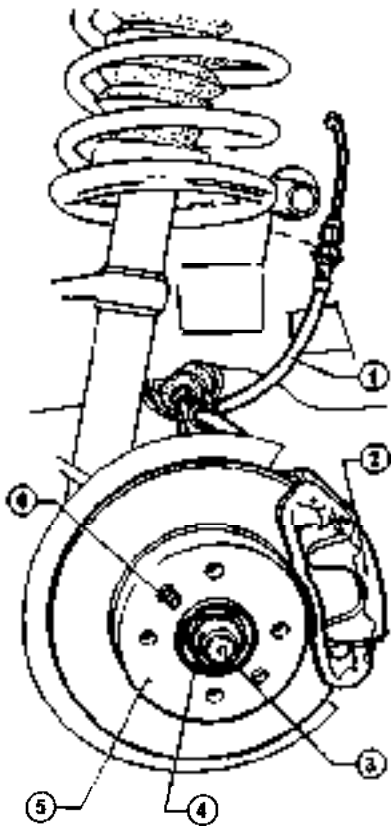

1 Hose 4 Hub nut
2 Caliper 5 Brake disc
3 Drive shaft 6 Dowel

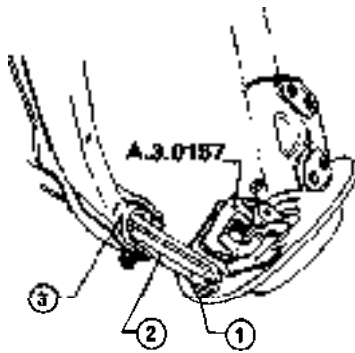

1 Ball joint 3 Link
2 Semi-trailing link

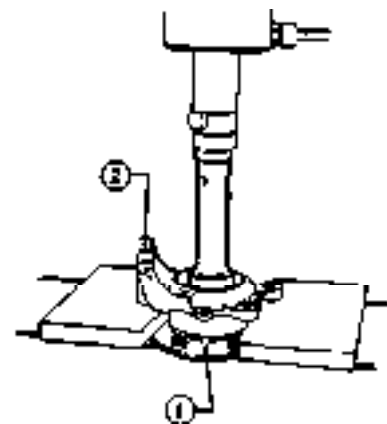

1 Hub 2 Hub support

DISASSEMBLY

6. Loosen and remove the four securing screws.

1. Clamp hub support in vice provided with protective jaws, unscrew dowel and remove brake dust cover (1) from hub support.

4. Reclamp hub support in vice provided with jaws and using a punch remove two calkings on ring nut securing bearing to support. Using and octagonal spanner with proper extension unscrew ring nut and

FRONT SUSPENSION

5. Withdraw bearing from hub support by means of press puller A.3.0302 and two plates.

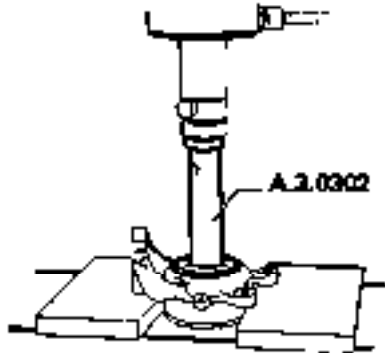

6. Reclamp hub in vice and using a suitable tool withdraw bearing inner race.

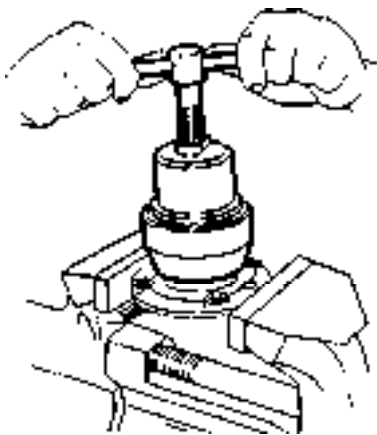

CHECKS AND INSPECTIONS

1. Carefully clean hub and hub support and visually check surfaces for damage. Replace damaged parts, if required.
2. Replace, at any rate, bearing assembly, ring nut and seal ring.

ASSEMBLY

1. Fit new bearing (2) to hub support (1) by means of press, tool A.3.0330 and stand A.3.0415.

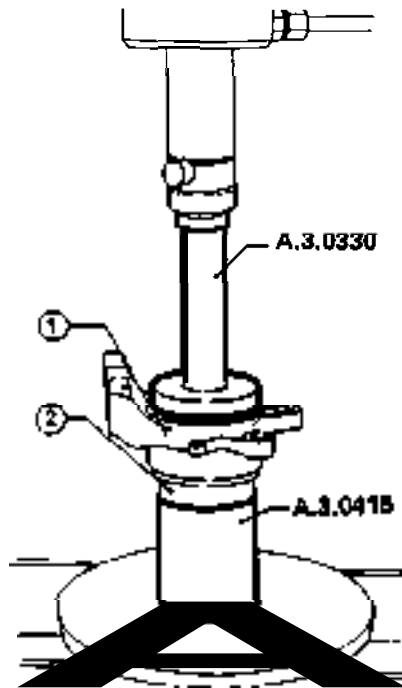

1 Hub support 2 Bearing

2. Clamp hub support in vice provided with jaws, fit a new ring and using octagonal spanner A.5.0239 screw ring nut into its seat on support, tightening it to the specified torque.

3. Caulk ring nut edge.

(T): Tightening torque
 Bearing ring nut
 $226 \div 225$ N-m
 $(23 \div 27)$ kg-m
 $116.3 \div 195.2$ ft-lb

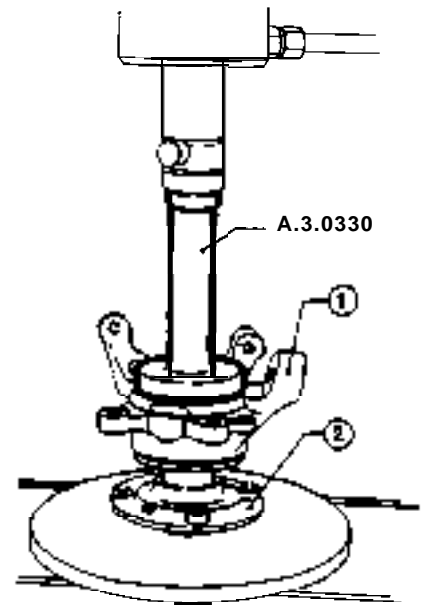
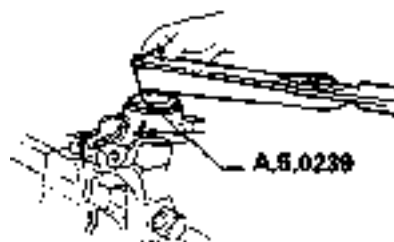

1 Hub support 2 Hub

5. Lubricate seal ring outer surface with prescribed oil (AGIPF1 Rotra HP SAE 80W90 or IP Pontiac HD 80W90) and fit ring in its seat on hub support by means of tool A.3.0330.

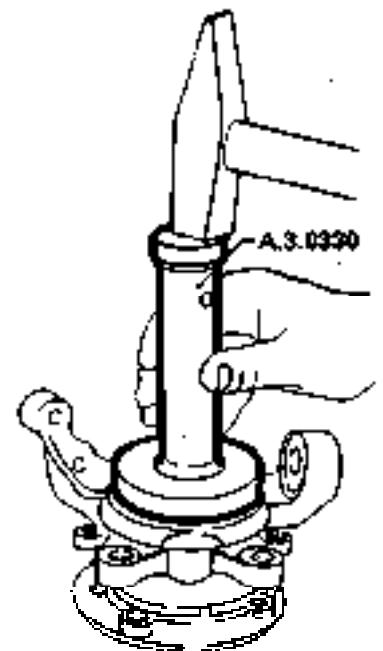

4. Insert support (1) into relevant hub (2) using press, tool A.3.0330 and plate.

6. Clamp hub support in vice provided with jaws and fit dust cover and brake disc.

FRONT SUSPENSION

INSTALLATION

1. Reinstall hub-hub support assembly in the reverse order of removal and tighten following parts to the specified torque values:

T : Tightening torques
 Nuts securing vertical guide to body
12 ÷ 15 N·m
 (1,2 ÷ 1,5 kg·m
 8,84 ÷ 11 ft·lb)

Screws securing hub support to strut bracket
39 ÷ 48 N·m
 (4 ÷ 4,9 kg·m
 28,9 ÷ 35,43 ft·lb)

Nut securing semi-trailing link ball joint to hub support
39 ÷ 48 N·m
 (4 ÷ 4,9 kg·m
 29,9 ÷ 35,43 ft·lb)

2. Refit caliper to hub support.

T : Tightening torque
 Screw fixing caliper on hub support
59 ÷ 74 N·m
 (6 ÷ 7,5 kg·m
 43,4 ÷ 54,2 ft·lb)

3. Refit shaft, by doing as follows:
 (1) Insert splined end into wheel hub.

(2) Connect shaft to differential drive shaft by locking the six securing screws to the designed torque.
 (3) By means of a **new** nut, secure shaft to wheel hub. Tighten nut to designed torque and caulk it.

T : Tightening torques
 Screws securing drive shaft to differential shaft
33 ÷ 36 N·m
 (3,4 ÷ 3,7 kg·m
 24,58 ÷ 26,75 ft·lb)

Nut securing wheel hub to shaft
226 ÷ 275 N·m
 (23 ÷ 28 kg·m
 116,3 ÷ 202,5 ft·lb)

FRONT SUSPENSION

COIL SPRING AND SHOCK ABSORBER

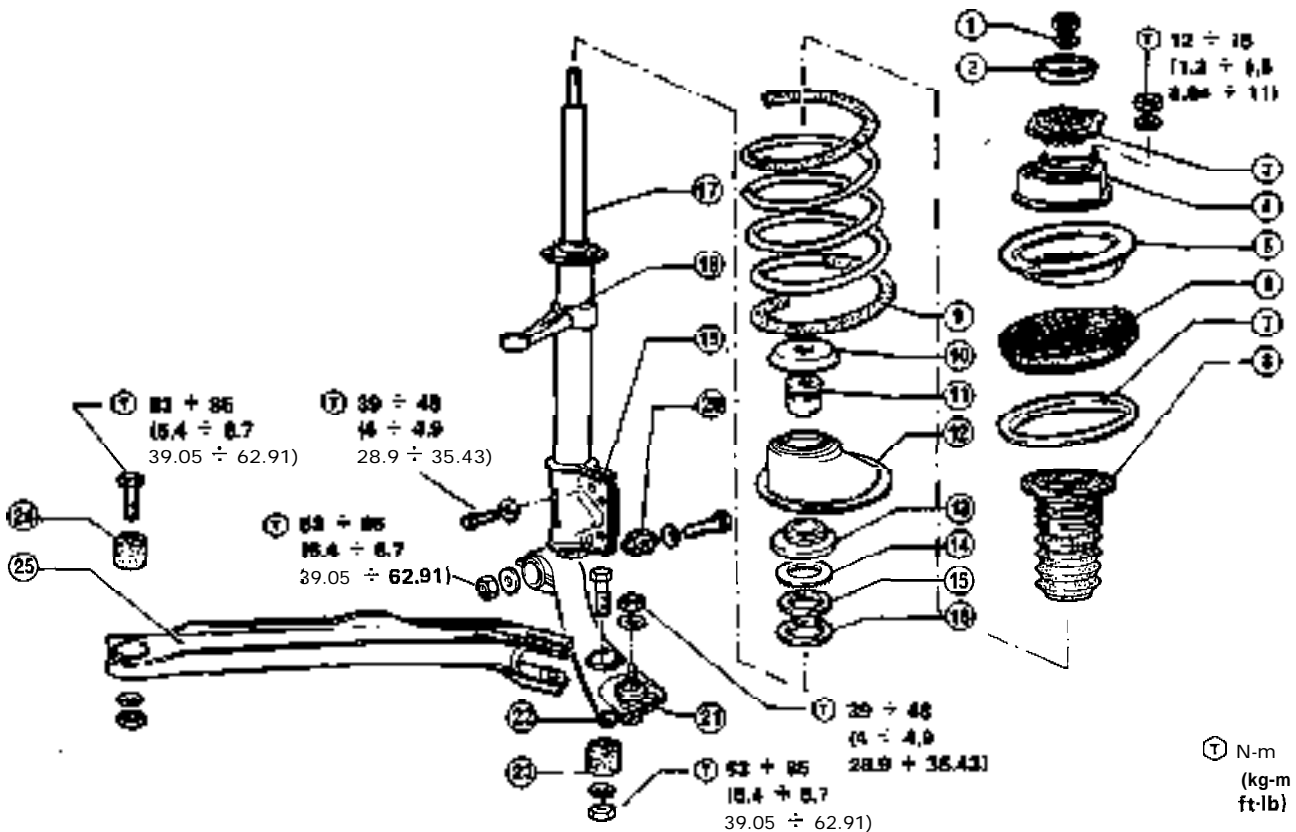

- 1 Washer
- 2 Upper washer
- 3 Rubber support
- 4 Complementary retainer
- 5 Retainer
- 6 Rubber seat
- 7 Upper cap
- 8 Boot
- 9 Spring

- 10 Lower washer
- 11 Rubber bound bumper
- 12 Lower cap
- 13 Lower retainer
- 14 Thrust bearing
- 15 Bearing washer
- 16 Seal ring
- 17 Strut
- 18 Steering lever

- 19 Strut bracket
- 20 Flexible bush
- 21 Semi-trailing link
- 22 Ball joint
- 23 Flexible bush
- 24 Transverse link
- 25 Flexible bush

T N·m
 (kg·m
 ft·lb)

FRONT SUSPENSION

REMOVAL

1. Place car on lift, block rear wheels, jack up front of vehicle, then support it by stands placed in adjacent position to jacking points (refer to: Group 00 - Lifting Points and Towing).
2. Remove four screws and wheel.
3. Unscrew nut securing ball pin of steering track rod (4) to lever (2) of strut (1).
4. Using A.3.0156 puller withdraw upwards pin of steering track rod (4) to lever (2) of strut (1).

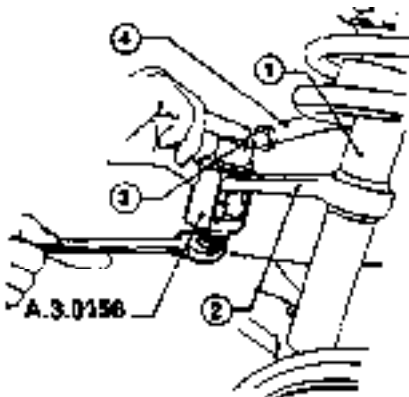

- | | |
|---------------|----------------------|
| 1 Strut | 3 Ball joint |
| 2 Strut lever | 4 Steering track rod |

5. Operating withing engine compartment, loosen and remove four nuts (2) securing strut to body (1).

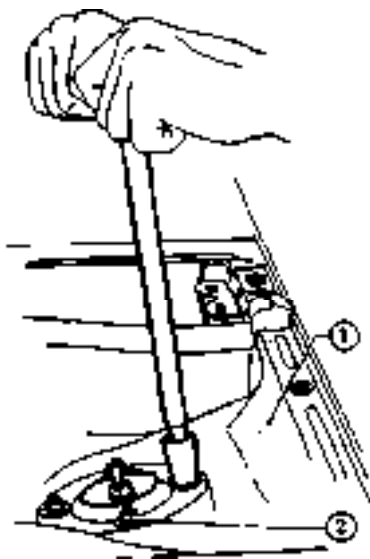

- | | |
|--------|-------|
| 1 Body | 2 Nut |
|--------|-------|

6. Hold strut properly, then loosen and unscrew the four screws (1) securing strut bracket to hub support.

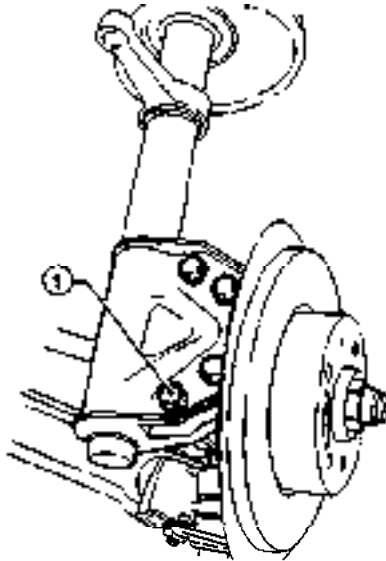

- 1 Screw

DISASSEMBLY

Clamp strut in vice and carry out disassembly as follows:

1. Hook spring by tool A.2.0251 and screw two nuts (2) of tool so as to progressively compress spring until upper cap is released.

WARNING:

Compress spring as minimum as possible so as to allow upper cap rotation with relevant gasket and retainer.

When compressing spring, ensure that tool is always hooked firmly to spring and lower cap.

2. Unscrew shock absorber securing nut (1) as shown on following figure.

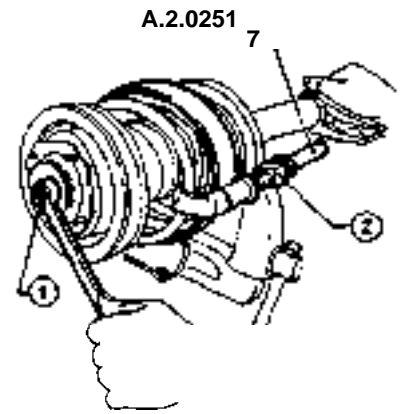

- | | |
|----------------|------------|
| 1 Securing nut | 2 Tool nut |
|----------------|------------|

3. Withdraw following parts (refer to figure of page 21-6): washer (1), upper washer (2), rubber support (3), complementary retainer (4), lower washer (10), with boot (8), spring rubber seat (6) with relevant retainer (3) and cap (7), rubber bound bumper (11), spring (9) with relevant lower cap (12) secured to compression tool.

If required, gradually release spring from tool, then separate spring from lower cap.

Then remove lever retainer (13) from spring lower cap.

4. Referring to the following figure, dismantle cap retainer (1) to following parts, taking care in numbering them and mark direction to be kept during assembly: roller thrust bearing (2), bearing washer (3) and lower seal ring (4).

Mark lower capas so as to identify them during assembly.

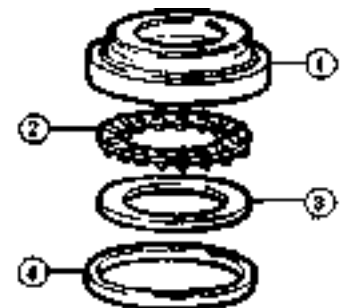

- | | |
|------------------|------------------|
| 1 Lower retainer | 3 Bearing washer |
| 2 Thrust bearing | 4 Seal ring |

CHECKS AND INSPECTIONS

Clean all the components.

Self-lubricating bush

Check self-lubricating bushes embodied in strut lower cap retainers for signs of excessive wear which are showed by metallic dust appearing on bush working surface.

Shock absorber

If required verified setting data relevant to shock absorber built-in strut. (Refer to Service Data and Specifications-Checks and Inspections).

Replace shock absorber in case they are removed because of inefficiency or oil leakages are detected.

Springs

Visually check springs for anomalous signs.

Rubber parts

Replace rubber parts if deformed, damaged or aged.

ASSEMBLY

1. Lubricate seal ring and thrust bearing of spring lower cap ① retainer with grease (AGIPF1 Grease 33 FD, IP Autogrease FD).

Refit all parts of retainer to strut complying with direction and order marked during disassembly.

2. If previously removed, refit tool A.2.0251 to spring ② and lower cap ① with tool clamped in vice; compress spring so that subsequent assembly procedure can be carried out.

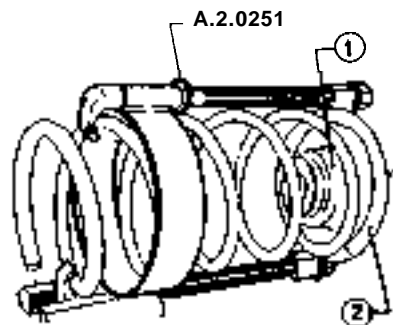

1 Lower cap 2 Spring

Refit remaining parts of strut assembly complying with sequence shown on figure.

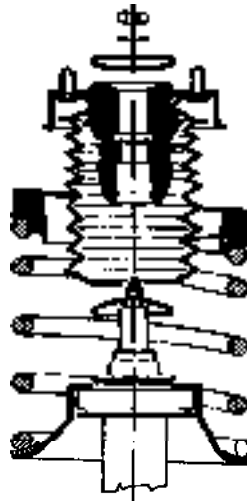

Spring lower and upper caps should be those corresponding with the side (righthand or lefthand) to which strut is installed.

INSTALLATION

1. Install strut in the reverse order of removal and tighten following parts to the specified torque:

Ⓡ : Tightening torque
 Screw securing hub support to strut bracket
 39 ÷ 48 N·m
 (4 ÷ 4.9 kg·m
 28.9: 35.43 ft·lb)

Nut securing strut to body
 12 ÷ 15 N·m
 (1,2 ÷ 1,5 kg·m
 8,84 ÷ 11 ft·lb)

Nut, steering tie rod ball joint on bracket lever
 39 ÷ 48 N·m
 (4 ÷ 4.9 kg·m
 28.9 ÷ 35.43 ft·lb)

TRANSVERSE AND SEMI-TRAILING LINK

REMOVAL

1. Place car on lift. Support front of vehicle on stands sited in adjacent position to jacking points and block rear wheels by hand brake.

2. Remove wheel from the operative side.
3. Loosen and remove shaft securing nut (wheel side).
4. Detach constant-speed joint from differential drive shaft by loosening the six securing screws and remove shaft.
5. Remove nut securing semi-trailing link ball joint pin ④ to hub support and withdraw pin using tool A.3.0157.
6. Loosen bolt ② securing transverse link ③ to engine cross member ① and bolt ⑤ securing to semi-trailing link ⑥, then withdraw the removing transverse link.
7. Loosen bolt ⑦ securing semi-trailing link to body and remove the link.

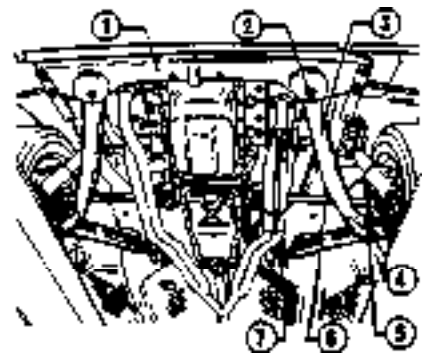

1 Cross member 5 Bolt
 2 Bolt 6 Semi-trailing link
 3 Transverse link 7 Bolt
 4 Fin

8. If required, after checking flexible joints: remove flexible joints from semi-trailing links and transverse links by means of proper tool.

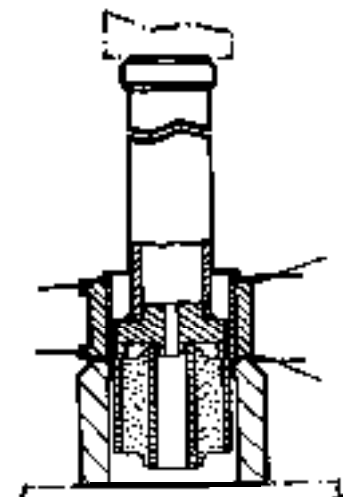

FRONT SUSPENSION

CHECKS AND INSPECTIONS

Clean all the components

1. Visually check semi-trailing links and front transverse links for blows, deformations, oxidation, cracks.
2. Examine condition of flexible bushes in semi-trailing and transverse link knuckles.
3. Check that semi-trailing link ball joint pivots free from crawlings or with notable slack in its seat.

Avoid flexible joints coming into contact with oil or grease.

INSTALLATION

1. If previously removed, it flexible joints, inserting them from the chamfered side, to semi-trailing link and front transverse link.

CAUTION:

To ease joints installation, lubricate outer surface with the fluid prescribed for rubber parts fitting to metallic seats (MILLOIL Slider for rubber sections; UNION CARBIDE CHEMICALS COMPANY Ucon Lubricant 50 HB - 5100).

2. Install transverse links and semi-trailing links to body in reverse order of removal and torque-tighten screw securing semi-trailing link ball joint pin to wheel support to the specified values.

Tighten fixing points of semitrailing and transverse link flexible joints to specified torque with car having its nominal height (see: Car Height).

 Tightening torque

Screw securing semi-trailing link ball joint pin to wheel support

39 ÷ 48 N·m
(4 ÷ 4.9 kg·m
28.9 ÷ 35.43 ft·lb)

Screw securing transverse and semi-trailing links

53 ÷ 85 N·m
(5.4 ÷ 8.7 kg·m
39.05 ÷ 62.91 ft·lb)

3. Refit drive shaft (see: Front Wheels Hub - Assembly).

SERVICE DATA AND SPECIFICATIONS

TECHNICAL DATA

COIL SPRING

Wire diameter	mm (in)	13.6 (0.535)
Coil diameter	mm (in)	160 (6.299)
Free length	mm (in)	293 (11.535)
Stiffness	N/mm (kg/mm) (lb/in)	24.5 (2.5) (140)

SHOCK ABSORBER

Shock absorber type		hydraulic
Piston rod diameter	mm (in)	20 (0.787)
Stroke	mm (in)	148.5 (5.846)

FRONT SUSPENSION

GENERAL SPECIFICATIONS

FLUIDS AND LUBRICANTS

Application	Type	Denomination	Q.ty
Seal ring and spring lower cap retainer thrust bearing	GREASE	AGIPF1 Grease 33 FD IP Autogrease FD Norm. 3671-69833/34	—
Hub support seal ring outer surface	FLUID	AGIPF1 ROTRA HP SAE 80W90 IP Pontiax HD 80W90 Norm. 3631-69408	—
Outer surface of the semitrailing link and front link silent block	FLUID	MILLOI L: Slider for rubber sections UNION CARBIDE CHEMICALS COMPANY Ucon Lubricant 50 HB-5100 Norm. 1500-I 7502	—

CHECKS AND INSPECTIONS

DATA OF SHOCK ABSORBERS SETTING



SHOCK ABSORBER		LEFT	RIGHT
Alfa Romeo Part Number		542.353	542.352
Low speed	Compression	N (kg) (lb)	107.9 ÷ 186.4 (11 ÷ 19) (24.25 ÷ 41.89)
	Expansion	N (kg) (lb)	215.8 ÷ 313.9 (22 ÷ 32) (48.5 ÷ 70.55)
High speed	Compression	N (kg) (lb)	421.83 ÷ 559.2 (43 ÷ 57) (94.8 ÷ 125.7)
	Expansion	N (kg) (lb)	1128.15 ÷ 1324.3 (115 ÷ 135) (253.5 ÷ 297.6)

NOTE: The shock absorbers are integrated in the strut tubes

FRONT SUSPENSION

Trouble	Probable cause	Corrective action
Steering wheel shocks, vibrations or shimmying (cont.)	<ul style="list-style-type: none"> • Excessive play in steering linkage • Loose screws securing steering box • Unserviceable shock absorber or loose securing points 	<p>Check and replace if required Tighten</p> <p>Tighten or replace</p>
Vehicle drifts or wanders	<p>Drifting becomes evident when vehicle is running on a flat surface with hands off steering wheel. Reference should also be made to: Group 25-Trouble Diagnosis and Corrections</p> <ul style="list-style-type: none"> • Worn or faulty tire • Improper tire air pressure and/or loose wheel nuts • Difference in height between right and left tire tread • Asymmetric suspension height • Incorrect steering geometry • Brake dragging • Worn suspension linkage flexible bush • Connection steering-suspension faulty 	<p>Replace</p> <p>Adjust and/or tighten</p> <p>Replace tire with thinnest tread</p> <p>Restore</p> <p>Restore</p> <p>Check and restore working conditions</p> <p>Replace worn components</p> <p>Replace faulty components</p>
Steering wheel excessive play	<ul style="list-style-type: none"> • Pinion-rack mating incorrectly adjusted • Worn steering components • Loose steering box securing screws 	<p>Adjust</p> <p>Replace worn components</p> <p>Tighten</p>
Noise	<ul style="list-style-type: none"> • Improper tire air pressure • Damaged and worn ball pin or steering parts; or lack in lubrication • Loose steering or suspension linkage • Faulty shock absorber • Faulty wheel bearing • Faulty suspension linkage bush • Damaged coil springs • Loose shock absorber securing nut 	<p>Adjust</p> <p>Replace or lubricate</p> <p>Tighten</p> <p>Replace</p> <p>Replace</p> <p>Replace</p> <p>Replace</p> <p>Tighten</p>
Tires squeal when taking a curve	<ul style="list-style-type: none"> • Improper tire air pressure • Incorrect steering geometry • Incorrect driving 	<p>Adjust</p> <p>Restore</p> <p>Avoid incorrect driving</p>
Abnormal tires wear (or uneven)	<ul style="list-style-type: none"> • Refer to: Group 28-Wheels and Tires 	<p>Wheels and tires</p>

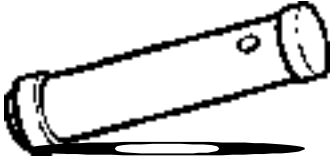
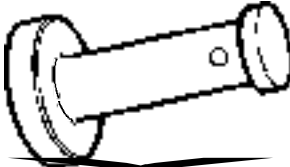
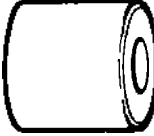
FRONT SUSPENSION

Tool number	Tool name	Refer to page
A.3.0302	Puller/driver of cup of front hub bearings 	21-5
A.3.0330	Driver of seal and bearing of front hubs (to be used with A.3.0415) 	21-5
A.3.0415	Base of withdrawal fitment (to be used with driver A.3.0330) 	21-5
A.5.0239	Wrench for bearing front hub nuts 	21-5

FRONT AND REAR BRAKES

GROUP 22

CONTENTS

DESCRIPTION	22-2	Control lever	22-17
Brake system bleeding	22-3	Control cables	22-18
Pedal assembly	22-4	SERVICE DATA AND	
Brake master cylinder	22-6	SPECIFICATIONS	22-19
Hydraulic system piping	22-8	General specifications	22-19
Brake pressure regulator valve	22-8	Inspection and adjustment	22-20
Servobrake	22-9	Tightening torques	22-21
Vacuum system	22-10	TROUBLE DIAGNOSIS AND	
Front disc brake	22-10	CORRECTIONS	22-22
Rear drum brake	22-15	SPECIAL SERVICE TOOLS	22-26
PARKING BRAKE	22-17		

Refer to Group 00 - Chassis and Body Maintenance
for:

- Brake System

SERVICE BRAKE

BRAKE SYSTEM BLEEDING

Bleed brakes following the procedure described hereafter and being careful to perform the following:

- a. Check that during bleeding the fluid level in the reservoir does not go below the "MIN" level.

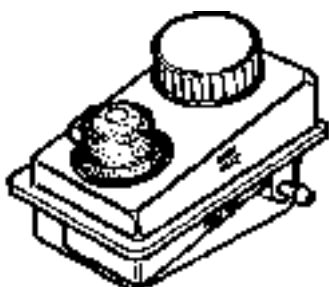

- b. Do not reuse the oil drained during bleeding operation.
- c. Work with extreme care in order to avoid damaging painted surfaces through contact with the fluid.

1. Place car on a lift.
2. If required, refill reservoir with specified fluid (ATE "S" or AGIPF1 Brake Fluid Super DE or IP Auto Fluid FR).
3. Remove dust covers from bleeders located on calipers or on wheel cylinders.
4. Carry out bleeding operations closely following the instructions described hereafter.

(1) Fit a small hose to the bleeder of each front brake caliper, of each rear wheel cylinder, and of bleed screw of brake pressure regulator. Place the hose other end into a transparent container previously partially filled with specified brake fluid.

(2) Loosen the above mentioned bleeders and press a few times the brake pedal all the way down, releasing it very slowly and waiting a few moments in between pressings. Repeat this operation till the fluid coming out of the hoses is free of air bubbles and then press once more

the pedal all the way down; now tighten the bleeders.

It is up to the operator whether to carry out the operation by operating at the same time or separately on the fire bleeder screws.

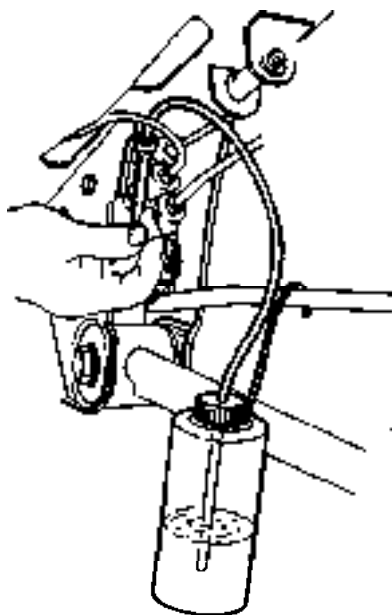
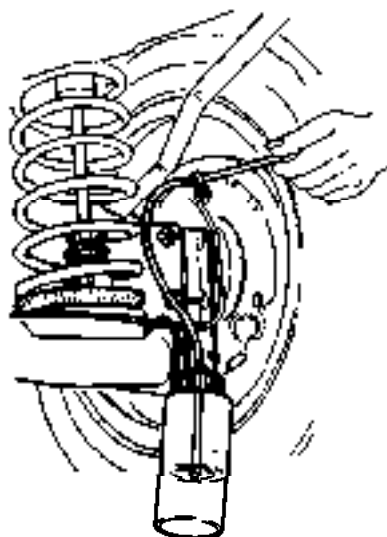
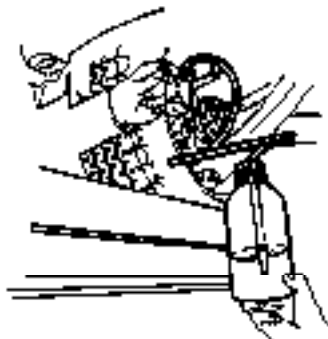

CAUTION:

During bleeding operation always keep the level of fluid in reservoir above the "MI N" level.

(3) Remove hoses from bleeders and fit relevant caps.

5. Press brake pedal all the way down and check whether; immediately after the pedal's initial free travel, you feel a direct action on the fluid without elasticity, if not so, repeat bleeding operation.

6. Restore fluid level in the reservoir and close it with relevant cap.

PEDAL ASSEMBLY

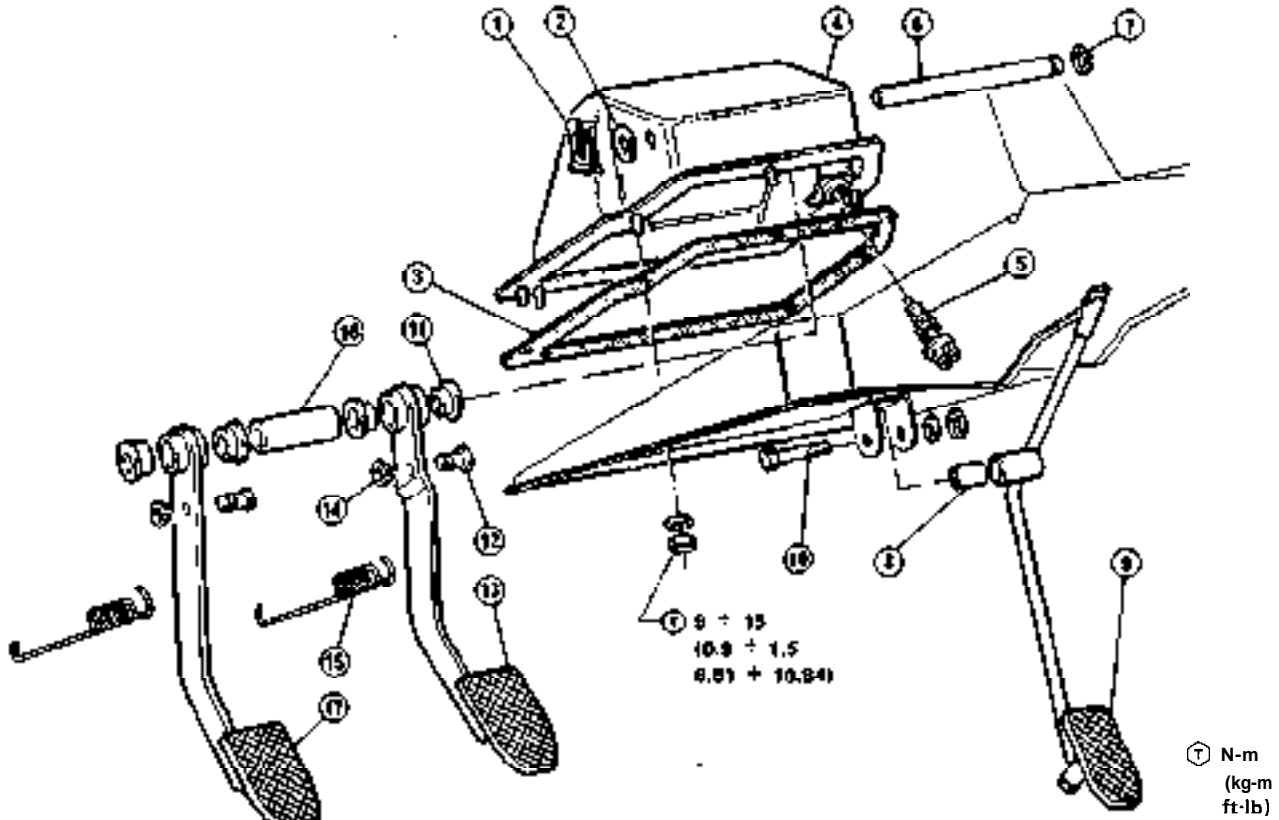

- 1 Retainer
- 2 Washer
- 3 Gasket
- 4 Pedal assy bracket
- 5 Stop light switch
- 6 Pin

- 7 Bull ring
- 8 Spacer
- 9 Accelerator pedal
- 10 Bolt
- 11 Plastic bush
- 12 Pin

- 13 Brake pedal
- 14 Bull ring
- 15 Spring
- 16 Spacer
- 17 Clutch pedal

Ⓣ N-m
(kg-m
ft-lb)

DISASSEMBLY

Carry out removal of pedal assembly operating as follows:

a. Engine seat

1. Disconnect electrical wiring ⑦ of brake fluid level warning light and with a syringe take out all brake and clutch fluid from reservoir ⑥.
2. Unscrew unions ④ connecting the four pipes that start out from the brake master cylinder ⑤. From clutch master cylinder ② remove the pipe ③ and the hose ① connecting it to the reservoir.
3. From servobrake remove the sleeve ⑨ connected to the vacuum intake pipe.
4. Remove screw ⑧ securing sheath clamp plate of the accelerator control cable.

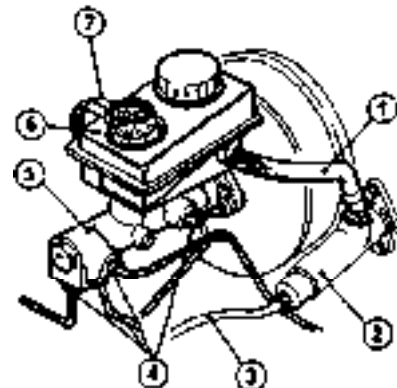
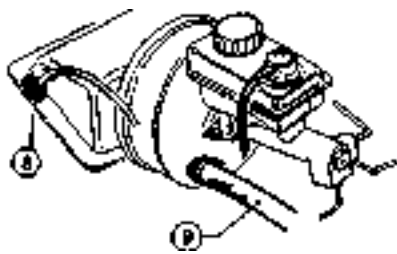

- 1 Hose
- 2 Clutch master cylinder
- 3 Pipe
- 4 Pipe unions
- 5 Brake master cylinder
- 6 Brake liquid tank
- 7 Electric cables
- 8 Screw
- 9 Sleeve

b. Passenger compartment

1. Separate from accelerator pedal the control cable ② and release electric connection ① of the stop light switch.
2. By removing retaining rings, return springs and connecting pins disconnect the brake and clutch pedals from control forks ⑤ and ⑥ of the relevant master cylinders.
3. By unscrewing the four securing nuts ③, separate from pedal assembly the servobrake - braker master cylinder unit.
4. By unscrewing the two securing bolts ④ remove clutch master cylinder from pedal assembly.
5. Unscrew the six nuts (set in evidence by figure) securing pedal assembly to body and remove pedal assembly from engine seat.
6. Remove, if necessary, the accelerator pedal from hinge to pedal assembly support by unscrewing bolt ④.

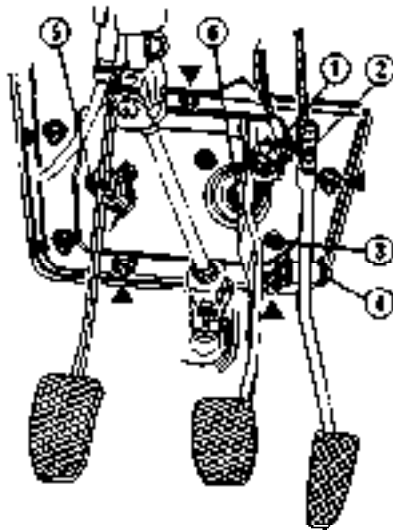

- | | |
|-----------------------|-------------------------------|
| 1 Electric connection | 5 Clutch master cylinder fork |
| 2 Cable | 6 Brake master cylinder fork |
| 3 Nut | |
| 4 Bolt | |

DISASSEMBLY

Disassemble pedal assembly operating as follows:

1. Remove retainer (1) of pedals pin (3) and washer (2).
2. Withdraw Pin and recover pedals (5) and (7), and spacer (6).
3. Remove plastic bushes (4) from pedals.

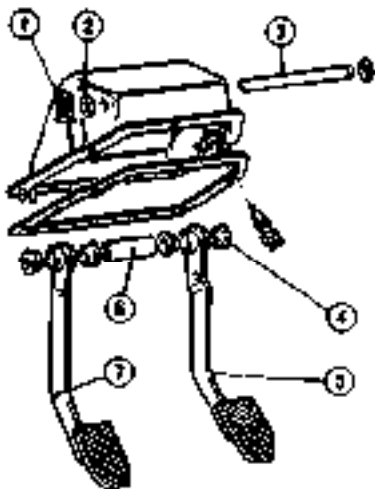

- | | |
|------------|----------|
| 1 Retainer | 5 Pedal |
| 2 Washer | 6 Spacer |
| 3 Pin | 7 Pedal |
| 4 Bush | |

CHECKS AND INSPECTION

1. Verify condition of pedals, of pedal assembly and gasket.
2. Check against presence of excessive wear and mesh in bushes, pin and spacer.
3. Check against presence of yield in return springs.
4. If necessary, remove and replace the stop light switch.

REASSEMBLY

For pedal assembly, reassembly, reverse the order of disassembly and apply a coat of the prescribed grease (AGIPF1 Grease 15) to the parts subject to sliding and to return springs.

INSTALLATION

1. Reinstall pedal assembly to body by reversing order of removal and complying with the following.
 - (1) Replace, if required, the gasket between pedal assembly and body.
 - (2) Tighten, to the prescribed torque, the nuts securing pedal assembly to body.

T: Tightening torque of pedal assembly nuts
 $9 \div 15 \text{ N}\cdot\text{m}$
 $(0.9 \div 1.5 \text{ kg}\cdot\text{m})$
 $6.51 \div 10.85 \text{ ft}\cdot\text{lb}$

- (3) Lubricate forks connecting both brake and clutch pedals to the relevant master cylinders, with AGIP F1 GREASE 15; then reconnect them.
2. Reconnect to pedal assembly the servobrake together with brake master cylinder and then clutch master cylinder.
3. If previously removed, reconnect accelerator pedal after lubricating spacer. Make sure that accelerator pedal can freely rotate after tightening securing nut to the prescribed torque.

T: Tightening torque
 $8 \div 10 \text{ N}\cdot\text{m}$
 $(0.8 \div 1 \text{ kg}\cdot\text{m})$
 $5.78 \div 7.23 \text{ ft}\cdot\text{lb}$

4. Lubricate end of accelerator cable before connecting it to pedal. Then, after securing the sheath clamp plate to pedal assembly, adjust its travel (see: Group 04 - Accelerator Control Adjustment).
5. Tighten to the prescribed torque the unions of brake master cylinder pipes and the union of clutch master cylinder pipe.

T: Tightening torques
 Unions of brake master cylinder pipes
 $8 \div 10 \text{ N}\cdot\text{m}$
 $(0.8 \div 1 \text{ kg}\cdot\text{m})$
 $5.78 \div 7.23 \text{ ft}\cdot\text{lb}$

Union of clutch master cylinder pipe
 $15 \div 19 \text{ N}\cdot\text{m}$
 $(1.5 \div 1.9 \text{ kg}\cdot\text{m})$
 $10.85 \div 13.74 \text{ ft}\cdot\text{lb}$

6. Fill the brake and clutch oil tank up to maximum level.
7. Carry out bleeding of brake hydraulic system (see: Brake System Bleeding) and of clutch (see: Group 12 Hydraulic Control Sub-assembly Hydraulic System Bleeding).

BRAKE MASTER CYLINDER

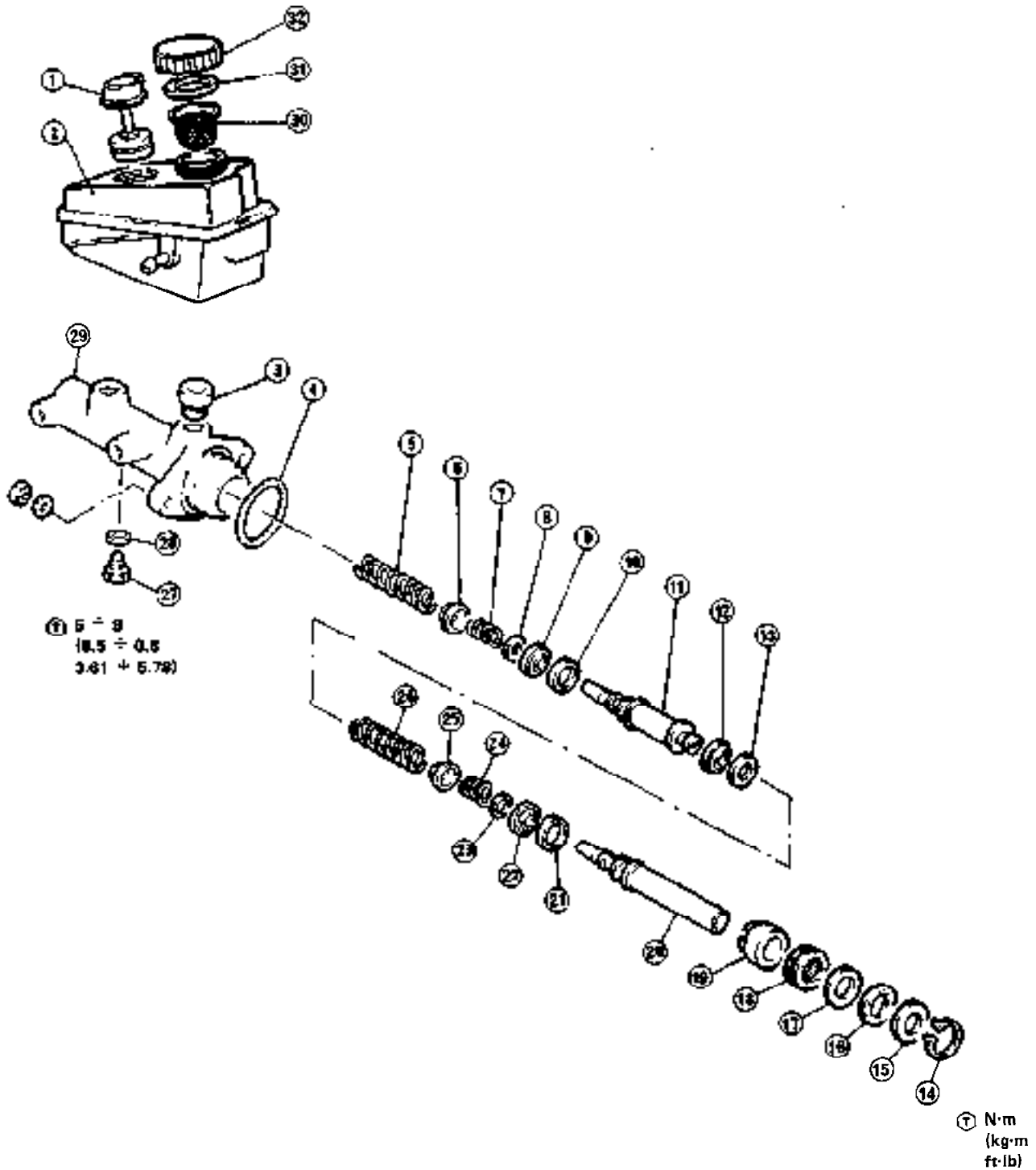

- 1 Level indicator
- 2 Reservoir
- 3 Union
- 4 Seal ring
- 5 Spring
- 6 Support disc
- 7 Spring
- 8 Washer
- 9 Gasket
- 10 Space sleeve
- 11 Intermediate piston

- 12 Gasket
- 13 Tab washer
- 14 Lock ring
- 15 End washer
- 16 Gasket
- 17 Washer
- 18 H shaped gasket
- 19 Bush
- 20 Push rod piston
- 21 Space sleeve
- 22 Gasket

- 23 Washer
- 24 Spring
- 25 Support disc
- 26 Return spring
- 27 Setscrew
- 28 Washer
- 29 Master cylinder body
- 30 Filter
- 31 Gasket
- 32 Cap

- b. Tighten to the prescribed torque two new nuts securing brake master cylinder to servobrake.

T: Tightening torque
 Brake master cylinder nuts to servobrake
BENDITALIA
 12 ÷ 15 N·m
 (1.2 ÷ 1.5 kg·m
 8.68 ÷ 10.85 ft·lb)

ATE
 21 ÷ 28 N·m
 (2.1 ÷ 2.9 kg·m
 15.2 ÷ 21 ft·lb)

- c. Pipes must be connected to master cylinder and tightened to the indicative prescribed torque.

T: Tightening torque
 Unions securing pipes to brake master cylinder
 8 ÷ 10 N·m
 (0.8 ÷ 1 kg·m
 5.78 ÷ 7.23 ft·lb)

- d. Fill reservoir up to proper level using only specified fluid (ATE "S" or AGIPF1 Brake Fluid Super ED, or IP Auto Fluid FR).

2. Bleed brake system (Refer to: Brake System Bleeding) and, if required, also clutch system (Refer to: Group 12 Subgroup Hydraulic Control - Hydraulic System Bleeding).

- syndrome in order to suck the liquid of brake clutch tank.
 b. As piping is removed, remember to plug up the ends in order to avoid foreign matter from entering.

- To remove pipes, loosen unions on both ends.
- To remove hoses, unscrew unions collecting pipes, to hoses and remove them. Then, disconnect hose on the other side.

- c. At the end of installation on car, both front and rear flexible cables must not result to be kink. For their check, take as reference the writing with the relevant manufacturer mark located on end of pipes, or the light coloured band (for front cables) located along pipe itself.

- d. Having completed installation of piping, fill up brake fluid reservoir to proper level and bleed the brakes (Refer to: Brake System Bleeding).

T: Tightening torques
 Hose unions of brake hydraulic system
 10 ÷ 15 N·m
 (1 ÷ 1.5 kg·m
 7.23 ÷ 10.85 ft·lb)

Pipe unions of brake hydraulic system
 8 ÷ 10 N·m
 (0.8 ÷ 1 kg·m
 5.78 ÷ 7.23 ft·lb)

3. Loosen and remove bolt (5) connecting the Panhard rod (4) to body and loosen the equalizer securing bolt (6).

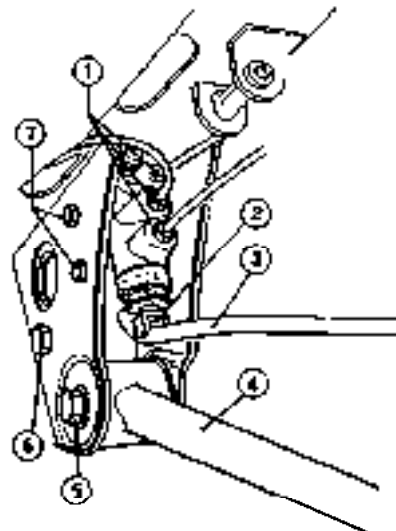

- | | |
|---------------|----------|
| 1 Unions | 5 Bolt |
| 2 Fork | 6 Bolt |
| 3 Spring | 7 screws |
| 4 Panhard rod | |

4. Lower Panhard bar in order to easy spring (1) withdrawing from pin (3), and from rubber ring (2) located on rod itself. Remove spring by withdrawing it from equalizer (4)
 5. If necessary, remove bolt (5) and equalizer.

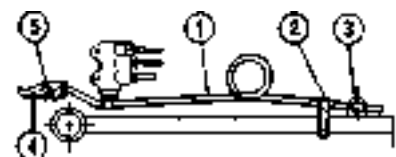

- | | |
|----------|-------------|
| 1 Spring | 4 Equalizer |
| 2 Ring | 5 Bolt |
| 3 Pin | |

HYDRAULIC SYSTEM PIPING

CHECKS AND INSPECTIONS

Thoroughly check all brake system piping (pipes and hoses) making sure they are not out of shape or cracked and that outer surfaces of pipes do not show any evidence of oxidation. Replace parts that are not flawless.

REMOVAL AND INSTALLATION

CAUTION:

- a. In case of removal or reinstallation of brake pipings, use a

BRAKE PRESSURE REGULATOR VALVE

REMOVAL

- Unscrew the three unions (1) of the brake pressure regulator pipes, taking care to close, by means of caps, the two feeding pipes of brake pressure regulator, in order to prevent tank emptying.
- Remove from body, the brake pressure regulator valve by unscrewing the two securing screws (7) and removing fork (2) from control spring (3).

CAUTION:

Do not disassemble components of the brake pressure regulator.

INSTALLATION

- Reinstall to body the brake pressure regulator valve by tightening bolts to the prescribed torque: 15 ÷ 24 N·m (1.5 ÷ 2.4 kg·m) (10.85 ÷ 17.35 ft·lb) and (if pre-

INSTALLATION

1. On bank, reconnect master cylinder to servobrake tightening securing nuts to the prescribed torque (see: Brake Master Cylinder - Installation).
2. For reinstallation on car of the whole unit, reverse order of removal and comply with the following.
 - (1) Tighten unions of pipes to the prescribed torque: $10 \div 14 \text{ N}\cdot\text{m}$ ($1 \div 1,4 \text{ kg}\cdot\text{m}$) ($7.23 \div 10.84 \text{ ft}\cdot\text{lb}$).
 - (2) Lubricate connecting pin with prescribed grease (AGIPF1GREASE 15); then reconnect fork to brake pedal.
 - (3) Restore level of brake fluid; then carry out bleeding (see: Brake System Bleeding).

2. Remove non-return valve ① after having removed relevant clips ②.

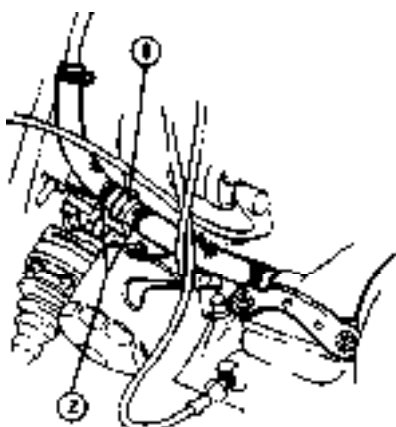

Valve 2 Clips

so that the crawfoot in the above figure points towards the intake manifold.

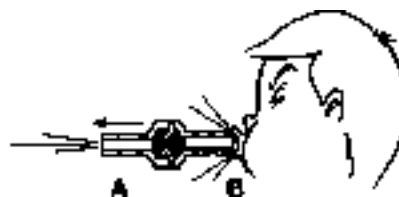

A Intake manifold side (black)
B Servobrake side (white)

3. Check valve thoroughly making sure it works properly, meaning that it allows air flow only in the direction shown by crawfoot.

4. When fitting non-return valve back to hose, be careful to position it

VACUUM SYSTEM

1. Visually check hoses making sure they are in no way damaged or clogged; also make sure clips are all properly tightened.

FRONT DISC BRAKE

DBA CALIPER

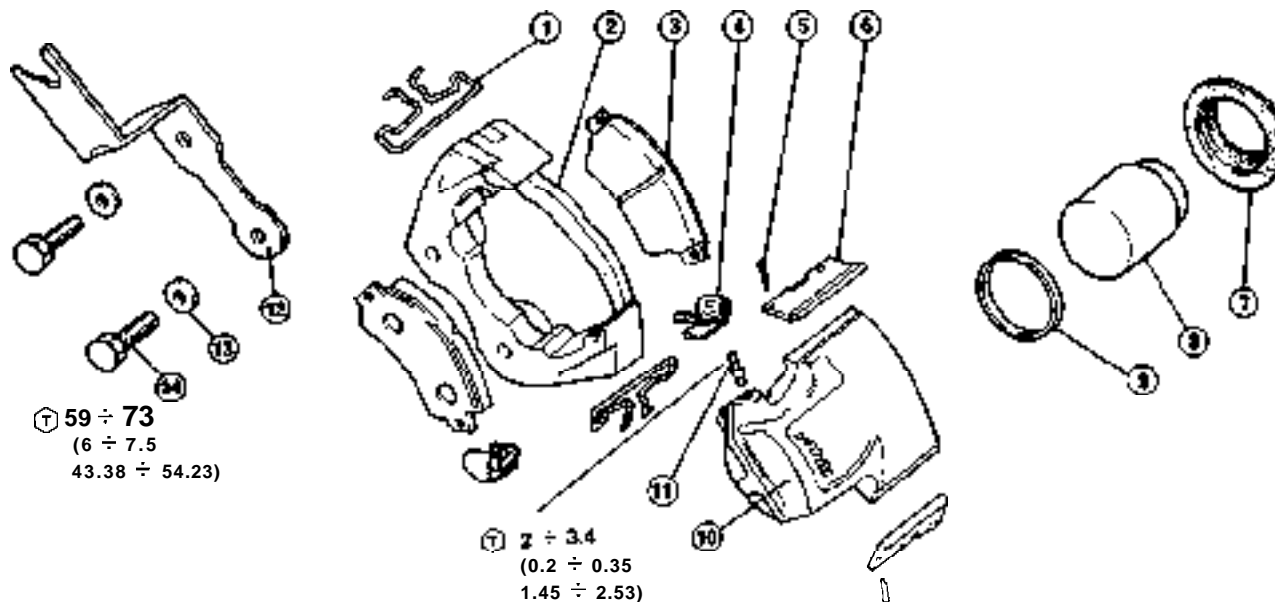

Ⓜ 59 ÷ 73
(6 ÷ 7.5
43.38 ÷ 54.23)

Ⓜ 2 ÷ 3.4
(0.2 ÷ 0.35
1.45 ÷ 2.53)

- | | |
|------------------------|---------------------|
| 1 Caliper setting clip | 7 Dust cover |
| 2 Caliper support | 8 Piston |
| 3 Pad | 9 Seal ring |
| 4 Pad retaining clip | 10 Floating caliper |
| 5 Retainers | 11 Bleeder |
| 6 Plate | 12 Bracket |
| | 13 Washer |
| | 14 Screw |

Ⓜ N·m
(kg·m
ft·lb)

Pad replacement

1. Lift car's front end positioning it on safety stands (Refer to: Group 00 - Lifting Points and Towing).
2. Using suitable pliers remove retainers ② from setting plates ① as shown in the figure below.

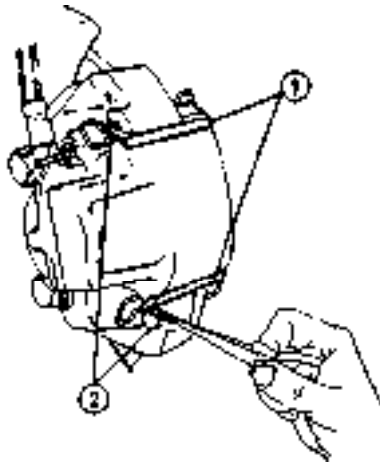

1 Plates 2 Retainers

3. With the help of a punch, push plates ① and ② and take them out.

Plates are not interchangeable.

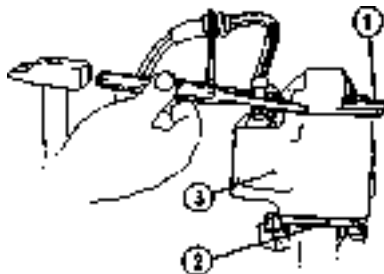

1 Upper plate 3 Floating caliper
2 Lower plate

4. Press floating caliper so as to push it toward the lower groove and then remove it from the support.

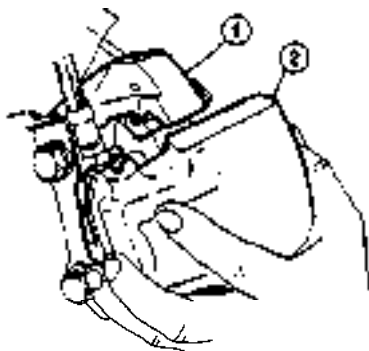

1 Caliper support 2 Floating caliper

5. Remove both pads, each with relevant dowel pin ①, and then remove pins from pads,

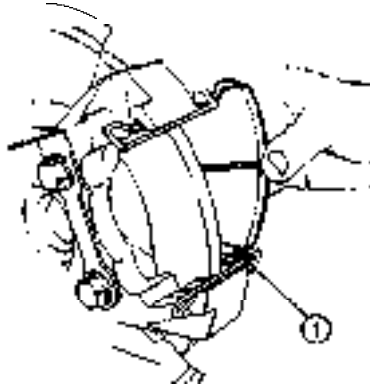

1 Fad dowel pin

CAUTION:

When pads are off, do not push brake pedal in order to avoid piston from being ejected from its seat on floating caliper. When replacing pads use only original spare parts and replace them on both calipers. Pad assembly must be carried out by positioning the crawfoot in the forward rotation direction of the brake disc.

6. Clean pads seats on caliper with alcohol.

CAUTION:

Do not lubricate in any way either the pads resting seats on calipers nor pad dowel pins.

7. Fit dowel pins on pads and then fit same into relevant seat.
8. Push piston towards its position into floating caliper.

CAUTION:

To avoid overflow of brake fluid when the piston is pushed back, it is advisable to suck some of the fluid from the reservoir by means a syringe.

9. Now fit the floating caliper and both setting plates.

CAUTION:

Do not lubricate setting plates.

10. Fit relevant retainer on each plate,

11. Restore proper brake fluid level in reservoir (ATE "S" or AGIPF1 Brake Fluid Super ED or IP Auto Fluid FR).

CAUTION:

To restore correct braking, push brake pedal all the way down a few times.

Caliper unit

REMOVAL

Remove caliper unit as follows:

1. By means of a syringe, suck brake fluid from feed tank.
2. Disconnect brake fluid hose ②.
3. Loosen and remove the two screws ① securing caliper unit to hub support and then remove the whole caliper unit.

CAUTION:

In case of caliper unit replacement, make sure that on front axle are mounted calipers of the same type only.

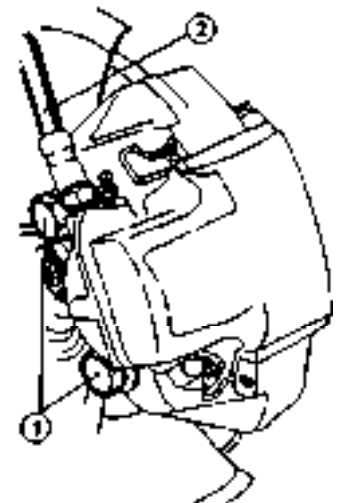

1 Securing screws 2 Hose

INSTALLATION

Fit back caliper unit as follows:

1. Fit caliper unit and bracket for brake fluid hose and then tighten relevant retaining screws to specified torque.

Ⓣ: Tightening torque

Caliper retaining screws
59 ÷ 73 N·m
(6 ÷ 7.5 kg·m
43.8 ÷ 54.23 ft·lb)

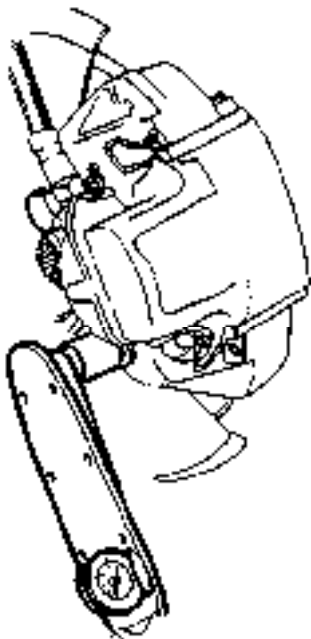

2. Connect brake fluid hose (Refer to: Hydraulic System Piping).
3. Fill brake fluid reservoir up to max. level (ATE "S" or AGIPF 1 Brake Fluid Super ED or IP Auto Fluid FR).
4. Bleed brake system (Refer to: Brake System Bleeding).

Floating caliper

DISASSEMBLY

If required, carry out disassembly of brake caliper operating as follows:

1. Empty brake fluid reservoir with a syringe.
2. Disconnect brake fluid hose.
3. Remove floating caliper (Refer to: Pad Replacement) and close it in a vice equipped with protecting jaws.
4. Remove dust cover (2) and then use a jet of compressed air to remove brake piston (3) from cylinder.
5. Remove seal ring (4) from its seat on cylinder.

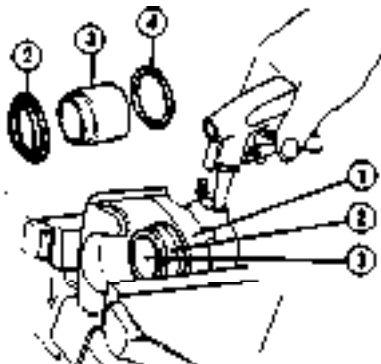

1 Floating caliper 3 Piston
2 Dust cover 4 Seal ring

CHECKS AND INSPECTIONS

Thoroughly wash all parts in alcohol and dry them with a jet of compressed air.

CAUTION:

Do not use metal tools and detergents containing mineral oil.

Floating caliper body

1. Check cylinder surface for cracks, evidence of excessive wear and presence of rust or foreign matter.
2. To remove rust or foreign matter, clean the surface with a very fine emery cloth.
3. In case of more severe damage replace floating caliper body.
4. Check bleeder and make sure it is in good working condition.

Piston

Check piston outer surface for cracks, evidence of excessive wear, deterioration and presence of rust or foreign matter. In case just one of above flaws is present, replace the piston or the whole floating caliper.

CAUTION:

Do not clean piston surface with emery cloth but go on and replace it.

Seal ring and boot

Replace seal ring and boot each time they are disassembled.

Caliper support

Check element good condition and replace it if necessary.

Clips

Make sure they are not damaged or abnormally worn; replace them if necessary.

INSTALLATION

If previously disassembled, carry out reassembly of floating caliper operating as follows:

1. Grease cylinder, piston and sealing ring applying a coat of the prescribed brake grease (Grease ATE Bremsylinder Paste or DBA Grease); fit seal ring on cylinder and then insert control piston.

2. Lubricate boot inner surface with the above mentioned grease, and fit it into its seat.

3. Fit floating caliper on relevant support (Refer to: Pad Replacement).

4. Connect oil pipe back to floating caliper and tighten relevant union to specified torque; fill reservoir up with specified brake fluid (ATE "S" or AGIPF1 Brake Fluid Super ED or IP Auto Fluid FR).

(T): Tightening torque
Brake pipe to caliper union
10 ÷ 14 N·m
(1 ÷ 1.5 kg-m
7.23 ÷ 10.84 ft·lb)

5. Bleed brakes (Refer to: Brake System Bleeding).

CAUTION:

At the end of installation on car, make sure that hose are not kink.

Brake disc

REMOVAL AND INSTALLATION

1. Remove from hub support, the whole brake caliper without disconnecting it from hose (see: Group 21 - Front Wheel Hub).
2. Remove brake disc from hub support after having removed the dowel pin.
3. Install disc and caliper following removal procedure in reverse sequence.

CHECKS AND INSPECTIONS

1. Thoroughly clean brake discs and check that working surfaces are not deeply scored or porous. Replace or machine them if necessary.
2. Should machining of disc working surfaces be required, keep in mind the following:

- (1) Always machine both surfaces of each disc, removing the same amount of material from each surface.
- (2) Machining must be performed according to tolerances indicated in the Service Data and Specifications Section - "Checks and Adjustments".

Pad replacement

1. Lift cars front end positioning it on safety stands (Refer to: Group 00 - Lifting Points and Towing).
2. Using a suitable punch, push pad dowel pins ① as shown, in the figure that follows:

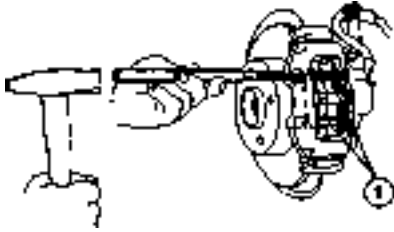

1 Pins

3. Remove, in sequence: the lower pin, the cross spring plate ①, and the upper pin.

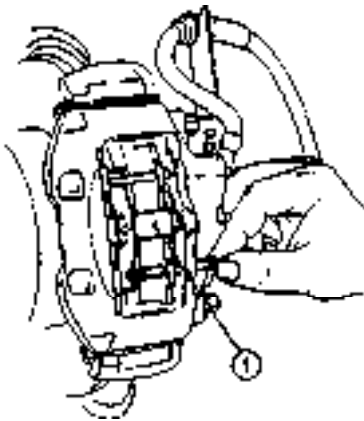

1 Cross spring plate

4. With suitable pliers, remove the pad on cylinder's side.
5. With a plastic hammer, strike floating caliper on cylinder's side thus removing the other pad.

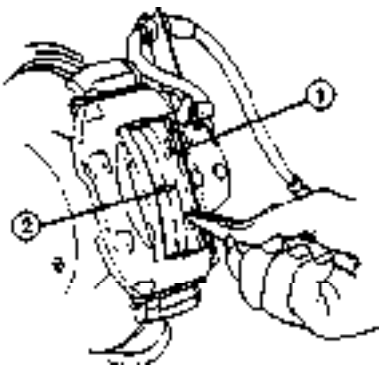

1 Pad on cylinder's side
2 Brake disc

CAUTION:

When pads are off, do not push brake pedal in order to avoid piston from being ejected from its seat on floating caliper. When replacing pads use only original spare parts and replace them on both calipers.

Pad assembly shall be carried out by positioning **crawfoot** towards the forward rotation direction of brake disc.

6. Clean pads' seats on caliper with alcohol.

CAUTION:

Do not lubricate in any way the pads' retaining seats on calipers.

7. Push piston back into floating caliper.

CAUTION:

To avoid overflow of brake fluid when the piston is pushed back, it is advisable to withdraw some of the fluid from the reservoir with a syringe.

8. Fit pads into their relevant seat and then complete assembly by fitting, in sequence: the first dowel pin, the cross spring plate, and the second dowel pin.

9. Restore proper brake fluid in reservoir (ATE "S" or AGIP F1 Brake Fluid Super ED or IP Auto Fluid FR).

CAUTION:

To restore correct braking, push brake pedal all the way down a few times.

Caliper unit

REMOVAL AND INSTALLATION

Removal and installation procedures of ATE calipers are like those of DBA calipers (Refer to: DBA Caliper Removal and Installation).

Floating caliper

DISASSEMBLY

If required, carry out disassembly of floating caliper, operating as follows.

1. Empty brake fluid reservoir with a syringe.
2. Disconnect brake fluid hose.
3. Remove pads (Refer to: Pad Replacement).
4. With a plastic hammer, strike floating caliper ① till it comes off from its support ②.

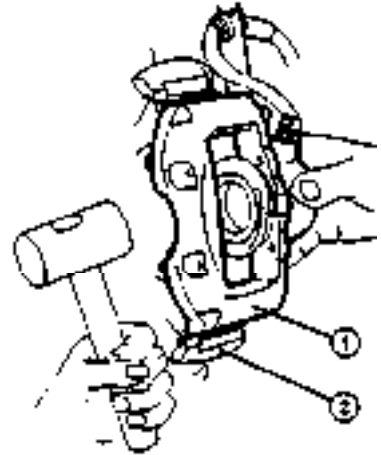

1 Floating caliper 2 Caliper support

5. Fit caliper on a vice equipped with protecting jaws and remove the dust covers ② lock ring ① as well as the boot.

6. Use a jet of compressed air to remove brake piston ③ from cylinder on floating caliper body ⑤.

7. Remove seal ring ④ from its seat on cylinder.



1 Lock ring 4 Seal ring
2 Dust cover 5 Floating caliper
3 Piston

CHECKS AND INSPECTIONS

For checks and inspections of ATE calipers, refer to: DBA caliper - Checks and Inspections.

INSTALLATION

If previously disassembled, carry out

FRONT AND REAR BRAKES

assembly of floating caliper, operating as follows.

1. Apply a coating of the prescribed brake grease to cylinder, piston and seal ring; fit seal ring on cylinder and then insert control piston.
2. Lubricate boot inner surface with the mentioned brake grease; then secure it with relevant lock ring.

Make sure boot and relevant lock ring are properly fitted.

3. Fit floating caliper on relevant support.
4. Connect oil pipe back to floating caliper.

 Tightening torque

Brake pipe to caliper union
 $10 \div 14$ N-m
 $(1 \div 1.5)$ kg-m
 $7.23 \div 10.84$ ft·lb)

5. Using a square caliper with a 20° angle, verify that brake control piston is properly positioned.

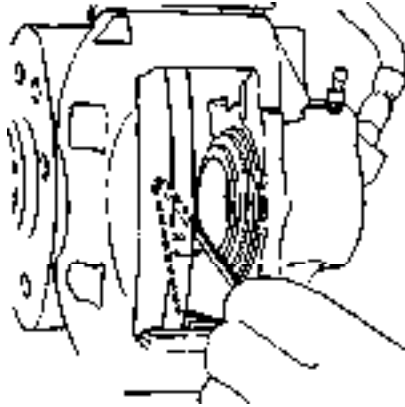

6. If the step on the piston does not match the square caliper's diagonal, rotate the piston with suitable pliers till the position required by the square caliper is reached.



7. Proceed and complete the assembly fitting the pads and securing them by means of relevant dowel pins (Refer to: Pad Replacement).
8. Fill reservoir up with specified brake fluid (ATE "S" or AGIPF1 Brake Fluid Super ED or IP Auto Fluid FR).
9. Bleed brakes (Refer to: Brake System Bleeding).

CAUTION:

At the end of installation on car, make sure that hose are not kink.

Brake disc

For all operations concerning brake discs refer to: DBA Caliper Brake Disc.

REAR DRUM BRAKE

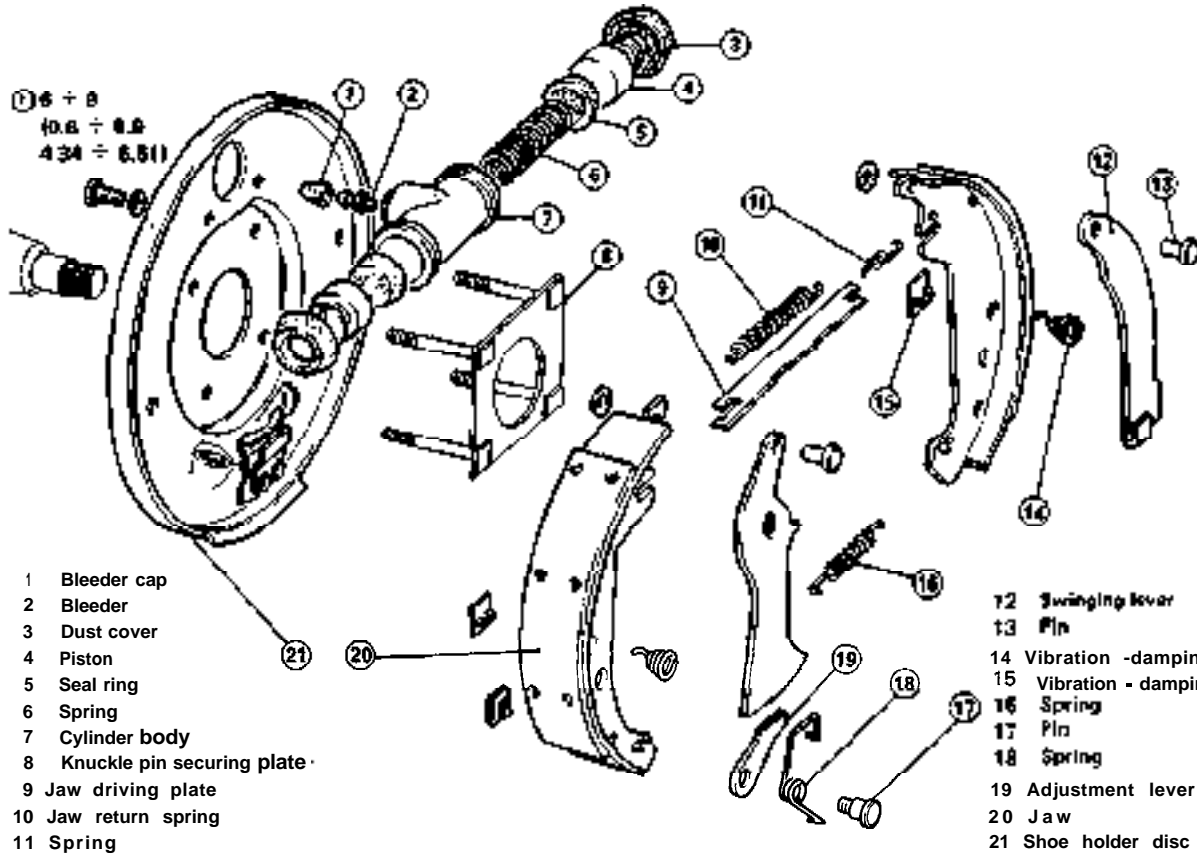

$\text{T} 6 \div 8$
 $40.8 \div 8.8$
 $4.34 \div 6.5(1)$

- 1 Bleeder cap
- 2 Bleeder
- 3 Dust cover
- 4 Piston
- 5 Seal ring
- 6 Spring
- 7 Cylinder body
- 8 Knuckle pin securing plate
- 9 Jaw driving plate
- 10 Jaw return spring
- 11 Spring

- 12 Swinging lever
- 13 Pin
- 14 Vibration -damping spring
- 15 Vibration - damping spring stop
- 16 Spring
- 17 Pin
- 18 Spring
- 19 Adjustment lever
- 20 Jaw
- 21 Shoe holder disc

 N-m
(kg-m
ft-lb)

JAW REPLACEMENT

Removal

1. Remove wheel and brake drum together with hub (see: Group 25 Rear Hub).
2. Operating from passenger compartment, loosen control cables of parking brake, by operating on adjustment nut and lock-nut.
3. Operating from wheel side, release control cable end ④ from lever ② and release it from fairlead ⑤.
4. By means of a suitable clamp release, in the following order: shoe upper return spring ①, shoe lower return spring ⑥. Remove then the jaw vibration - damping springs ③.

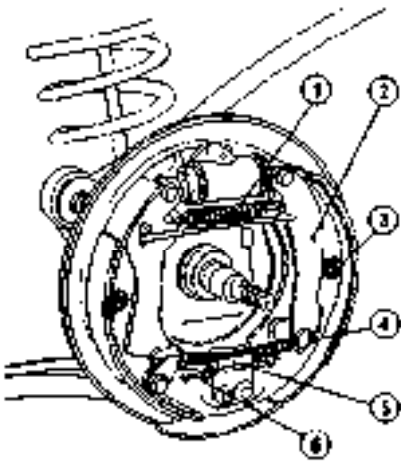

- | | |
|----------------------------|---------------------|
| 1 Upper spring | 4 Control cable end |
| 2 Lever | 5 Fairlead |
| 3 Vibration damping spring | 6 Lower spring |

5. Remove the two jaws from brake holder disc and if required, separate them, after releasing spring ① from jaw jointing square ②.

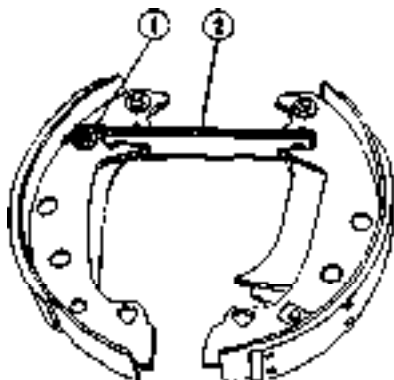

- | | |
|----------|----------|
| 1 Spring | 2 Square |
|----------|----------|

6. Disassemble, (if required) the adjustment device, operating as follows:

- (1) Remove retain spring ⑤, then from jaw, withdraw pin ④ together with spring ② and lever ③ of the adjustment device.
- (2) Remove seal ring ⑥ and separate from jaw the swinging lever ① of the adjustment device.

The removed seal rings must anyway be replaced during reassembly.

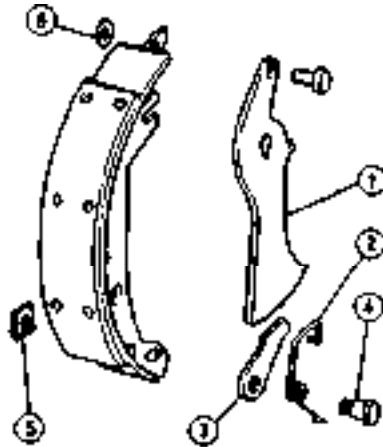

- | | |
|------------------|-----------------|
| 1 Swinging lever | 4 Pin |
| 2 Spring | 5 Retain spring |
| 3 Lever | 6 Seal ring |

7. If previously disassembled, reassemble the adjustment device after lubricating the following contact surfaces:

- Swinging lever nut and adjustment device lever nut.
- Contact surfaces between adjustment device and swinging lever.

Installation

To correctly position the new jaws on brake holder disc, operate by reversing order of removal and coupling with the following:

- a. Lubricate with brake grease contact surfaces between the under mentioned components.
 - jaws and opening control cylinder.
 - toothed surfaces of the jaw adjustment device.
 - gears of the jaw return springs.
- b. On installed jaws, before assembling drum, set the adjustment device lever so as to maximum reduce opening of jaws.

- c. On installed drum, adjust distance between jaw-drum by repeatedly operating on brake pedal.
- d. Adjust travel of parking brake control lever (see: Group 00 Chassis and Body Maintenance).

CYLINDER FOR JAW OPENING CONTROL

Removal

1. Remove jaws (see: Jaw Replacement - Removal).
2. Disconnect the oil delivery piping to jaw opening cylinder, by operating on union ②, as shown in figure.
3. Unscrew and remove the two screws ① securing cylinder to brake holder disc; then remove cylinder.

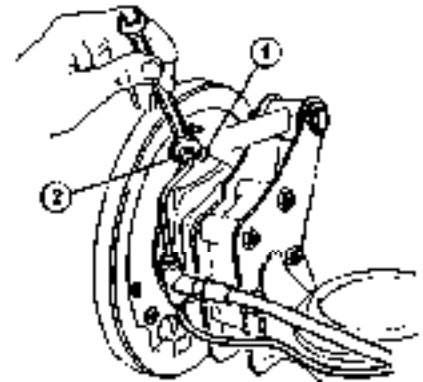

- | | |
|----------|---------|
| 1 Screws | 2 Union |
|----------|---------|

Disassembly

1. Remove dust covers ① from cylinder body ④, then, pick up the jaw opening control pistons ②, together with gasket ③, which are ejected by spring ⑤; then withdraw spring itself.
2. Remove bleeder protection cap ⑦ and remove bleeder.

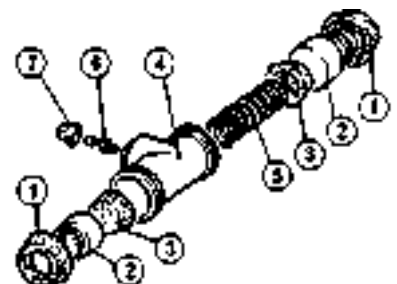

- | | |
|-----------------|-----------|
| 1 Dust cover | 5 Spring |
| 2 Piston | 6 Bleeder |
| 3 Gasket | 7 Cap |
| 4 Cylinder body | |

placed between support and body.

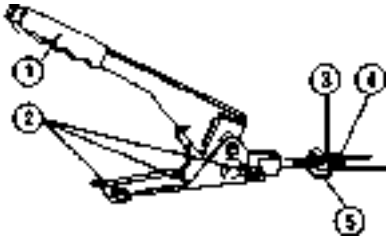

- 1 Lever
- 2 Screws
- 3 Nut
- 4 Lock nut
- 5 Bracket

DISASSEMBLY

With reference to the following exploded view remove the control lever operating as follows.

1. Withdraw cotter pin from

pin ⑭ connecting lever ② to adjusting fork ⑮, withdraw pin with washers from fork and separate this one from the lever.

2. Unscrew bolt ⑫ securing the lever to its relevant support ⑬ and separate the two components.

3. Withdraw bush ⑨ and handle ① from lever, remove pin stopper cotter ⑧ on which ratchet gear pawl ⑦ rotates and withdraw the pin from its seat.

4. Separate from lever the whole block of ratchet gear control with pushbutton ③, spring ④, stopper ⑤, rod ⑥ and pawl ⑦.

5. If necessary, remove switch of the parking brake indicator from brake support.

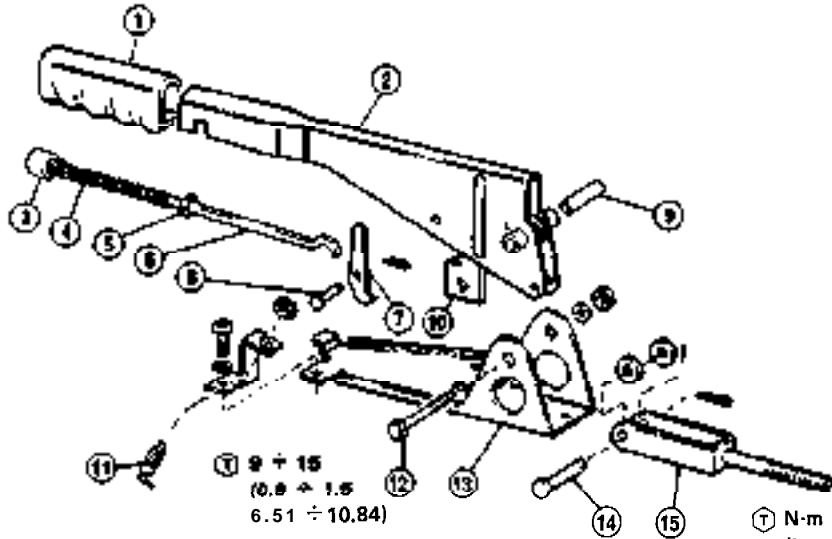

- 1 Handle
- 2 Lever
- 3 Pushbutton
- 4 Spring
- 5 Stopper
- 6 Rod
- 7 Pawl
- 8 Pin
- 9 Bush
- 10 Sector gear
- 11 Light switch
- 12 Bolt
- 13 support
- 14 Pin
- 15 Adjustment fork

CHECKS AND INSPECTIONS

1. Check components visually against excessive wear and other damages. Check, in particular, surface conditions of the lever coupling bush to support, and wear conditions of pawl teeth and scroll gear.
2. Check against presence of electric cable discontinuity and that parking brake indicator switch is properly functioning.
3. Replace worn or faulty components.

REASSEMBLY

For reassembly of the support and lever unit, reverse the order of assembly and, in particular comply with the following:

1. Lubricate brake lever bush and ratchet gear components with specified grease (AGIP F1 Grease @ or SHELL Retinax G11).
2. Tighten to specified torque of 9 ± 15 N-m (0.9 ± 1.5 kg-m), (6.51 ± 10.84 ft-lb) bolt hinging lever to brake support.

REINSTALLATION

To reinstall control lever with support, reverse the order of removal and complying with the following:

1. Apply a coat of specified grease (AGIP F1 Grease 15 or SHELL Retinax G11) to surfaces where cables slide in the incoved section and to fork adjusting screw.
2. Carry out parking brake adjustment (see: Group 00 Chassis and Body Maintenance).

CONTROL CABLES

REMOVAL

1. Operating from the driver's compartment remove rear console and, by operating lock nut and nut of adjustment fork loosen control cables and withdraw them from equalizer.
2. Remove rear wheel and drum together with hub (see: Group 25 - Rear Hub - Removal).
3. Operating on wheel side release control cable end ③ from lever ② and free it from fair-lead ④. Release control cable from brake shoe holder ①, withdraw it from this last and remove it after releasing it from the underbody clamps.

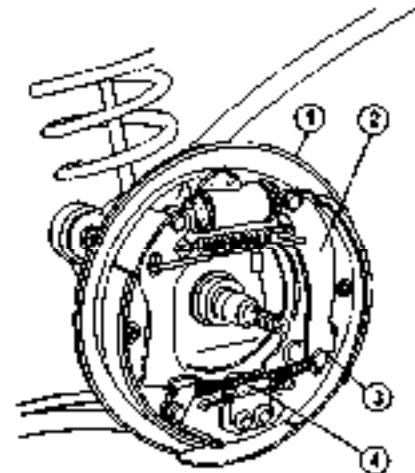

- 1 Brake shoe holder
- 2 Lever
- 3 Control cable
- 4 Fair lead

CHECKS AND INSPECTIONS

Make sure that control cables are sound; replace them if necessary.

FRONT AND REAR BRAKES

BRAKE PRESSURE REGULATOR VALVE

Adjustment.

- Unloaded car
- Valve piston at end of travel
- Load: 60 N (6 kg) (13.22 lb) applied to hook of fixture A.4.0148

HANDBRAKE LEVER ADJUSTMENT

Number of free notches on the sector gear before wheels locking 1 ÷ 3

TIGHTENING TORQUES

Unit			
Item	N·m	kg·m	ft·lb
Unions of brake hydraulic system pipes	8 ÷ 10	0.8 ÷ 1	5.78 ÷ 7.23
Unions of brake hydraulic system (on calipers and union of shoe holder plate)	10 ÷ 15	1 ÷ 1.5	7.23 ÷ 10.84
Union of clutch system pipe	15 ÷ 19	1.5 ÷ 1.9	10.84 ÷ 13.74
Screws retaining caliper to wheel hub	59 ÷ 73	6 ÷ 7.5	43.8 ÷ 54.23
Screw securing front brake disc to wheel hub	6 ÷ 8	0.6 ÷ 0.8	4.34 ÷ 5.78
Bolts securing knuckle pin to axle	3 9 ÷ 44	4 ÷ 4.5	28.9 ÷ 32.53
Nut securing pedal assembly unit to body	9 ÷ 15	0.9 ÷ 1.5	6.51 ÷ 10.84
Intermediate piston setscrew for ATE brake master cylinder	5 ÷ 8	0.5 ÷ 0.8	3.61 ÷ 5.78
Nut jointing brake master cylinder to servobrake			
BENDITALIA	12 ÷ 15	1.2 ÷ 1.5	8.67 ÷ 10.84
ATE	21 ÷ 28	2.1 ÷ 2.8	15 ÷ 21
Securing bolt of brake pressure regulator valve	15 ÷ 24	1.5 ÷ 2.4	10.84 ÷ 17.3
Equalizer securing nut	39 ÷ 48	4 ÷ 4.9	28.9 ÷ 35.4
Panhard bar securing bolt	69 ÷ 85	7 ÷ 8.7	50.6 ÷ 62.9
Screws securing wheel cylinder to back plate	6 ÷ 9	0.6 ÷ 0.9	4.34 ÷ 6.51
Bolt fixing parking brake lever to support	9 ÷ 15	0.9 ÷ 1.5	6.51 ÷ 10.84

TROUBLE DIAGNOSIS AND CORRECTIONS

The following are the indispensable presuppositions for any trouble diagnosis of braking system verification of:

- Tyre wear
- Tyre pressure
- Brake fluid or any way, verification of compliance with programmed maintenance specifications.

Condition	Probable cause	Corrective action
Excessive pedal travel	<ul style="list-style-type: none"> • Leakage in brake master cylinder • Leakage in clutch master cylinder • Faulty no-return valve of vacuum system • Fluid leakage from brake pressure regulator • Fluid leakage from braking system unions • Air in system • Faulty brake adjustment 	<p>Overhaul brake master cylinder</p> <p>Overhaul clutch master cylinder</p> <p>Replace check valve</p> <p>Adjust or replace</p> <p>Tighten unions</p> <p>Bleed system</p> <p>Adjust shoe-to-drum clearance</p>
Spongy pedal	<ul style="list-style-type: none"> • Air in system • Faulty brake adjustment • Reservoir filler cap vent hole clogged • Swollen hose due to deterioration or use of poor quality hose • Distorted brake shoes, or excessively worn or cracked brake drum • Soft or swollen caliper seals • Use of a brake fluid with too low boiling point 	<p>Correct as necessary</p> <p>Adjust shoe-to-drum clearance</p> <p>Clean and bleed system</p> <p>Replace hose and bleed system</p> <p>Replace faulty parts</p> <p>Drain hydraulic system, flush with alcohol and replace all seals</p> <p>Replace with specified brake fluid and bleed system</p>
Poor braking effect	<ul style="list-style-type: none"> • Fluid leakage in brake lines • Air in brake lines • Excessive shoe-to-drum clearance • Grease oil mud or water on linings or pads 	<p>Check master cylinder, piping and wheel cylinder for leaks, and repair</p> <p>Bleed system</p> <p>Adjust</p> <p>Clean brake mechanism and check for cause of problem. Replace linings or pads</p>

FRONT AND REAR BRAKES

Condition	Probable cause	Corrective action
Poor braking effect (continued)	<ul style="list-style-type: none"> • Deterioration of linings or pads • Local fit of linings or pads • Master cylinder or wheel cylinders in poor condition • Frozen or seized caliper pistons on disc brakes • Binding mechanical linkage at brake pedal and shoes 	<p>Replace linings and/or pads. If necessary grind discs and turn drums</p> <p>Replace linings and/or pads. If necessary grind discs and turn drums</p> <p>Repair or replace</p> <p>Disassemble caliper and free up as required</p> <p>Free up as required</p>
Unbalanced brakes	<ul style="list-style-type: none"> • Improper tire inflation • Improper adjustment of shoes-to-drum clearance • Grease oil mud or water on linings or pads • Mud in brake drum • Excessive wear or deterioration of linings or pads • Wheel cylinder in poor condition • Poor sliding condition of brake shoe • Looseness of cylinder body or back plate securing bolts/nuts • Scored or out-of-round drums • Brake pressure regulator incorrectly adjusted or not efficient • Deteriorated wheel cylinder seal rings • Incorrect adjustment of wheel bearings • Incorrect adjustment of wheel alignment 	<p>Inflate to correct pressure</p> <p>Readjust</p> <p>Clean brake mechanism and check for cause of problem. Replace linings or pads</p> <p>Clean</p> <p>Replace</p> <p>Repair or replace</p> <p>Adjust</p> <p>Fasten or replace</p> <p>Recondition or replace brake drum as required. Check for improper lining contact with drum and grind lining if necessary</p> <p>Adjust or overhaul (if required) or replace brake pressure regulator</p> <p>Recondition or replace cylinder</p> <p>Adjust</p> <p>Adjust</p>
Brakes fade	Use of improper linings or brake linings are contaminated	Replace linings

FRONT AND REAR BRAKES

Condition	Probable cause	Corrective action
Pedal pulsates	<ul style="list-style-type: none"> • Out-of-round or off-center drum • On disc brakes, lateral runout of brake rotor is excessive • Excessive variation in thickness of brake rotor surfaces 	<p>Turn drum or replace as necessary</p> <p>Check with dial indicator, turning disc by hand. If runout exceeds specifications, repair or replace disc</p> <p>Measure around disc face with micrometer. Replace disc as required</p>
Rear lock (Under light brake pedal force)	Faulty brake pressure regulator	Replace
Rear lock (Under heavy brake pedal force)	<ul style="list-style-type: none"> • Poor front braking effect • Grease oil mud or water on linings or pads • Excessive wear of linings or pads • Local fit of linings or pads • Master cylinder or wheel cylinder in poor condition 	<p>Disassemble and adjust front brakes</p> <p>Clean or replace</p> <p>Replace</p> <p>Shave or replace</p> <p>Repair or replace</p>
Servobrake out of order	<ul style="list-style-type: none"> • Air leakage at check valve • Air leakage at seal ring between vacuum box and control body • Air leakage at disc valve • Air leakage at piston seal ring • Air leakage at seal ring between master cylinder and servobrake • Damaged piping or connectors 	<p>Inspect check valve</p> <p>Replace servobrake assembly</p> <p>Replace seal ring</p> <p>Repair or replace</p>
Not adjustable engine idle speed (no leakage at connectors)	Engine sucks air through servobrake	Replace check valve or servobrake assembly
Parking brake does not brake	<ul style="list-style-type: none"> • Improper adjustment • Front and rear cables damaged or broken • Faulty connection of rear cables to brakes 	<p>Adjust</p> <p>Replace cables</p> <p>Check cable connection</p>
When parking brake control lever is released, the car remains braked	<ul style="list-style-type: none"> • Shoes are jammed on drums • Return travel of cables is obstructed 	<p>Unlock or replace faulty parts</p> <p>Remove obstacle and replace cables</p>

FRONT AND REAR BRAKES

Condition	Probable cause	Corrective action
When parking brake control lever is released, the car remains braked (continued)	<ul style="list-style-type: none"> • Control lever release pushbutton does not spring back 	Disassemble lever, and release or replace if
The brake ON indicator does not illuminate	<ul style="list-style-type: none"> • Wires disconnected • Faulty switch • Faulty lamp 	Restore connection Replace Replace

SPECIAL SERVICE TOOLS

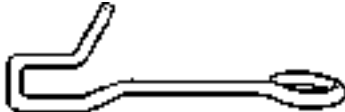
Tool number	Tool name	Refer to page
A.4.0148	Tool for calibrating brake pressure regulator <div style="text-align: center; margin-top: 10px;">  </div>	22-9 22-7

STEERING SYSTEM

GROUP 23

CONTENTS

STEERING SYSTEM	23-2	Removal	23-7
GENERAL DESCRIPTION	23-2	Disassembly	23-8
STEERING WHEEL AND COLUMN . . .	23-2	Checks and inspections.	23-9
Steering wheel	23-2	Assembly	23-9
Steering column	23-3	SERVICE DATA AND	
Steering lock-ignition switch	23-4	SPECIFICATIONS	23-1 1
STEERING LINK RODS	23-5	General specifications	23-11
Removal	23-5	Inspections and adjustments	23-12
Checks and inspections	23-6	Tightening torques	23-1 2
Disassembly	23-6	TROUBLE DIAGNOSIS AND	
Assembly.	23-6	CORRECTIONS	23-13
Installation	23-6	SPECIAL SERVICE TOOLS	23-13
STEERING BOX	23-7		



STEERING SYSTEM

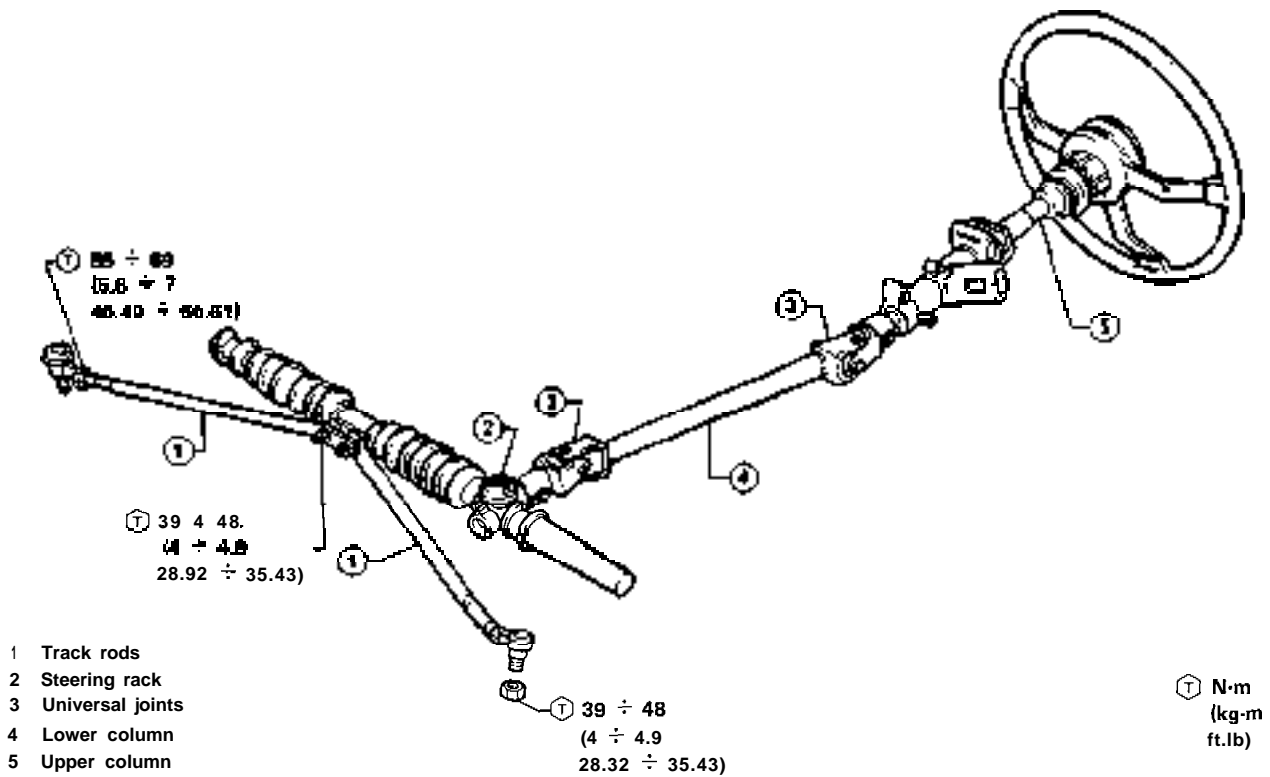

GENERAL DESCRIPTION

Steering is by rack and pinion. The track rods are connected to the centre of the rack by means of flexible joints. Owing to their length,

they reduce the variation of wheel movement resulting from suspension movements. The steering column is in two sections. The lower part

is positioned so as to collapse under axial loads. The upper part is pivoted to allow adjustment of the steering column height.

STEERING WHEEL AND COLUMN

STEERING WHEEL

REMOVAL

1. Remove hub (1), to gain access to screws (2) securing warning horn pushbutton (3) on steering wheel and remove them.
2. Disconnect electric connection (4) of warning horn pushbutton and remove it.
3. Unscrew and remove nut (5) with washer (6) securing steering wheel to column.

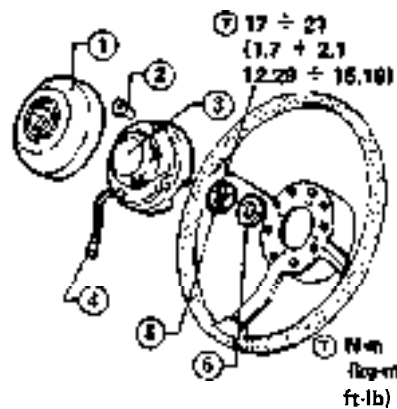

4. By means of tool A.3.0451, withdraw steering wheel from column operating as per figure.

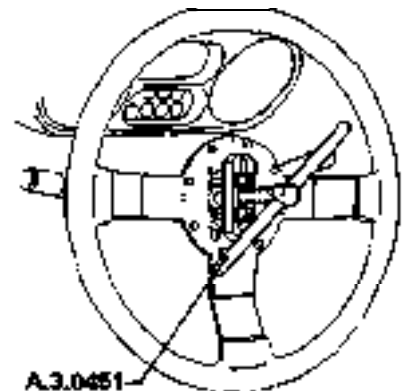

STEERING SYSTEM

9. Remove the whole column.

DISASSEMBLY

1. Unscrew bolt securing universal joint to upper column section. Remove lower column.

2. Remove steering lock operating as follows.

Secure column support ① together with upper column ② on vice fitted with protective jaws and, operating as shown in figure, unscrew the broken head screw securing steering lock to column support; withdraw steering lock.

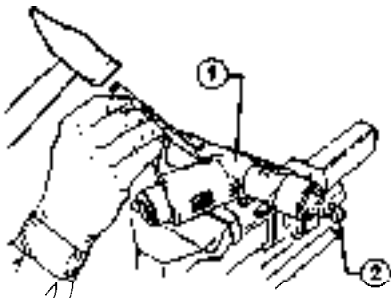

1 Column support 2 Upper column

3. Keeping the unit on a vice, hammer, on upper column, by means of a plastic hammer (as shown in figure) as long as column can be withdrawn from support with relevant upper bearing.



4. Withdraw lower bearing from column support.

CHECKS AND INSPECTIONS

1. Check against presence of damages or malfunctions in column bearings. Lubricate them with the prescribed grease and replace them

if necessary.

2. Check against presence of damages or absence of lubrication in universal joints. Replace lower column if necessary.

3. Verify integrity of upper column and, in particular, that: working surfaces of bearings are safe from scratches; tooth of splined parts are not damaged or worn; hole where pin of steering lock works, is sound.

4. Verify integrity of column support -and replace it if necessary.

ASSEMBLY

For reassembly reverse order of disassembly and comply with the following:

- Apply a coat of grease (AGIP F1 Grease 33 FD or IP Autogrease FD) to bearings where upper column rotates.
- Lower bearing must be completely introduced on column support and upper bearing must be assembled so as it faces upper plane of support.
- Verify that upper column can freely rotate and that no excessive clearance is present.
- For securing of steering lock - ignition switch to column support, make use of proper screw supplied as spare part, which must be tightened into its seat until breaking of its head.
- During junction of lower column to upper one make sure that securing bolt positions correctly with respect to cutout portion.

INSTALLATION

Assemble column by proceeding in reverse order and follow these instructions.

WARNING:

Make sure that undue stress is not applied to steering column during assembly.

- Loosen the wheels and couple the column lower universal joint to pinion of steering box, then insert securing bolt ① making sure that it positions correctly with respect to pinion cutout portion ②.

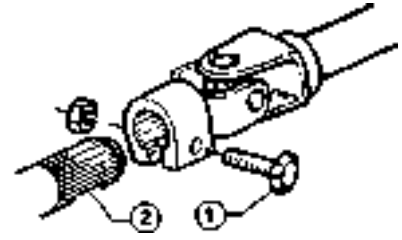

1 Bolt 2 cutout

- Adjust tightening of steering wheel inclination lever so as to obtain correct stop of steering wheel in the required position.
- On steering wheel and cover assembled, make sure that, on all lowered position of steering wheel, B dimension (between cover of steering column and steering wheel structure) corresponds to the prescribed value.

Distance between cover and steering wheel structure

$$B = 0 \div 6 \text{ mm } (0 \div 0.236 \text{ in})$$

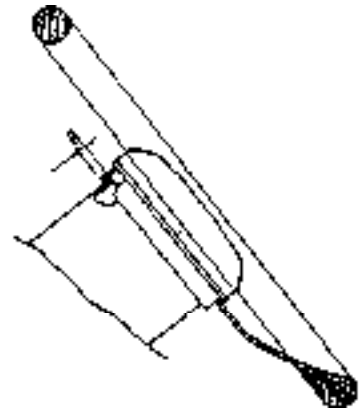

- After tightening of components, verify that on maximum travel condition of steering wheel, (straight ahead and straight down) functioning is correct.
- At the end of assembly, verify proper functioning of combination switch unit and efficiency of warning horn.

STEERING LOCK- - IGNITION SWITCH

REMOVAL AND INSTALLATION

- Remove lower cover of column support (see: Column - Removal).
- Disconnect harness of the steer-

STEERING SYSTEM

ing lock - ignition switch.

- Remove the broken head screw securing steering lock to column support.
- Remove steering - lock unit withdrawing it from its seat in column support.
- For installation, reverse order of removal and secure steering lock ① to column support by means of special screw ② provided as spare part, and tighten it as long as its head breaks.

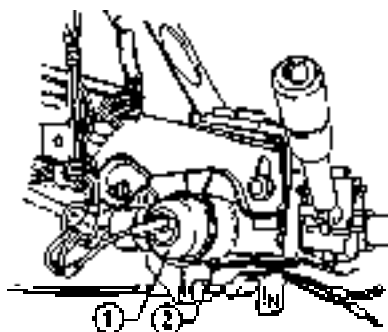

1 Steering lock
2 Screw

CHECKS AND INSPECTIONS

- Verify good conditions of cables and connectors.
- Check proper operation of the whole assembly by verifying all positions are reached smoothly; check also the locking device operations properly, after rotating steering wheel and extracting key.

STEERING LINK RODS

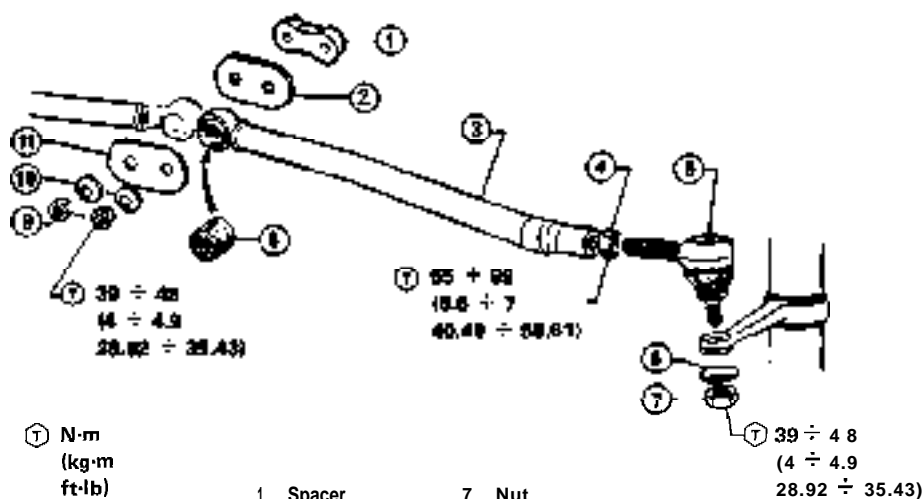

- | | |
|--------------|-----------------|
| 1 Spacer | 7 Nut |
| 2 Plate | 8 Elastic joint |
| 3 Rod | 9 Nut |
| 4 Nut | 10 Washer |
| 5 Ball joint | 11 Plate |
| 6 Washer | |

REMOVAL

- Place car on lift, block rear wheels, jack up front of vehicle, then support it by stands placed in adjacent position to jacking points (Refer to: Group 00 - Lifting Points and Towing).
- Remove four screws and wheel.
- Unscrew nut securing ball pin of steering track rod ④ to lever ② of strut ①.
- Using puller.A.3.0156 withdraw ball joint pin ③ of steering track rod upwards, taking it out from strut levers.

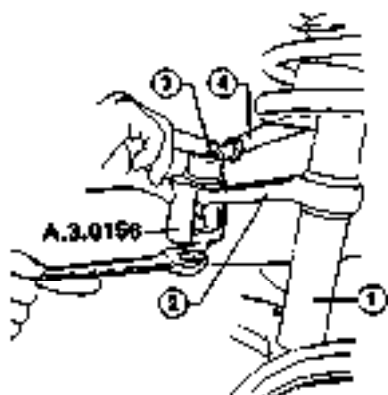

1 Strut
2 Strut lever
3 Ball joint
4 Steering track rod

- Turn steering wheel to the right to make easier the disassembly of rods ① from steering box ②, remove nuts ③, washers ④, and plate ⑤, then remove rods.

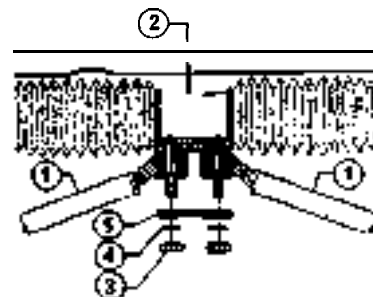

1 Rod
2 Steering box
3 Nut
4 Washer
5 Plate

CHECKS AND INSPECTIONS

1. Check against damage or wear in the steering rods ball joints, and verify that pivot free from crawling or with notable slack in their seats. If necessary, replace them.
2. Check elastic joints against damage, wear or excessive slack. If necessary, replace them.
3. Check steering rods against damage or deformations. If necessary, replace them.

DISASSEMBLY

1. Extract elastic joints from rods by means of a press and of suitable tools (a punch and a base).

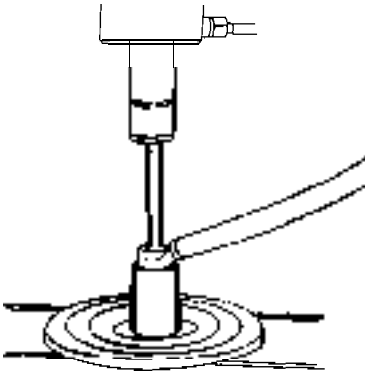

2. Measure articulation jut in order to maintain it on reassembly.

3. Loosen fixing nut (2), unscrew ball joint (3) and remove it from rod (1).

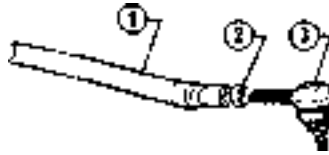

- 1 Rod
2 Nut
3 Ball joint

ASSEMBLY

Proceed in reverse order to disassembly and use the same tools previously used.

On reassembly of ball joints, make sure that the two tie rods have the same length they had before disassembly.

INSTALLATION

Assemble steering link rods on vehicle by proceeding in reverse order of removal.

- 1 Assemble rods on steering box studs and fix them with plate, washers and nuts without locking them.
2. Connect rods to levers on steering tubes by tightening the nuts securing the ball joint pin to the specified torques.

During tightening of bolts, make sure that on the static load position, upper plane of ball pin is parallel to gasket face.

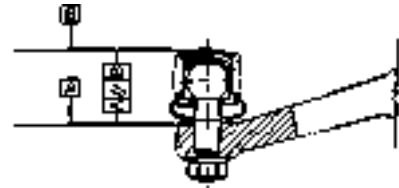

3. Lock the elastic joint fixing nuts to the rack studs, with the front suspension in nominal height, corresponding to static load.

T : Tightening torque
Nut fixing ball joint to lever on steering tube and elastic joint to rack.
39 ÷ 48 N-m
(4 ÷ 4.9 kg-m
28.92 ÷ 35.43 ft-lb)

4. Verify toe-out (Refer to: Group 00 - Chassis and Body Maintenance).

STEERING BOX

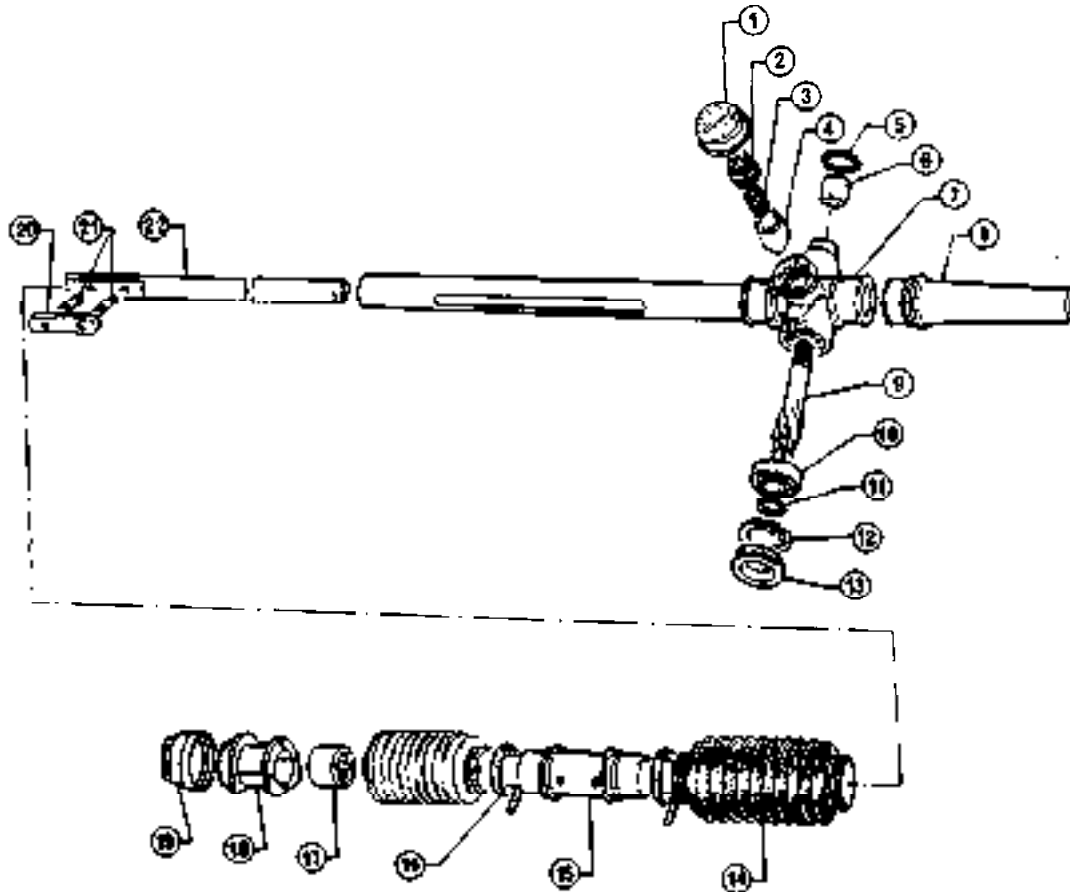

- 1 upper cap
- 2 Adjusting screw
- 3 Spring
- 4 Plunger
- 5 Seal ring
- 6 Bush
- 7 Rack box
- 8 Left cap

- 9 Pinion
- 10 Bearing
- 11 Lock ring
- 12 Lock ring
- 13 Lower cap
- 14 Boot
- 15 Sleeve
- 16 Clamp

- 17 Bush
- 18 support
- 19 Right cap
- 20 Pad
- 21 Studs
- 22 Rack

REMOVAL

1. Place vehicle on ramp and support it by stands placed in the jack seats (refer to: Group 00 Lifting Points and Towing).
2. Remove left wheel after screwing up fixing screws.
3. Turn steering wheel to the right and disconnect rods from steering box (refer to: Steering Link Rods - Removal).
4. Disassemble bolt (2) fixing lower universal joint (1) to pinion (3)
5. Remove plastic cap (4) protecting rack.

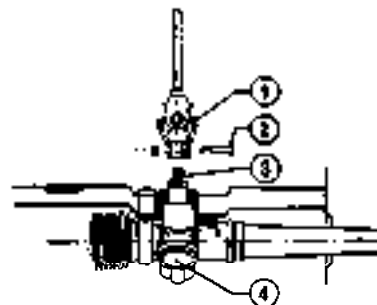

- 1 Universal joint
 - 2 Bolt
 - 3 Pinion
 - 4 Protection cap
6. Remove screws (6) fixing steering box (1) to body, then remove brackets (5).
 7. After disengaging pinion (2) from universal joint (3), remove

steering box by extracting it from the steering rod slit on the left side and remove rubber supports (4).

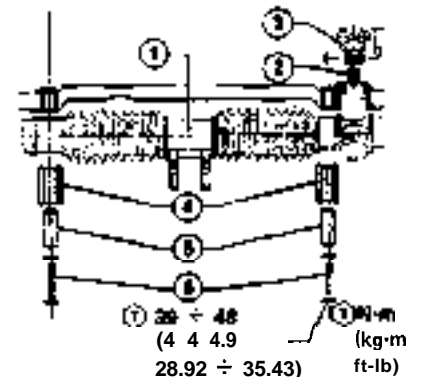

- 1 Steering box
- 2 Pinion
- 3 Universal joint
- 4 Support
- 5 Bracket
- 6 Screw

DISASSEMBLY

1. Remove clamp (4) fixing right boot (3) to sliding sleeve (5).
2. Extract end cap (1), remove plastic support (2) and extract right boot (3).

CAUTION:

Plastic bellows be replaced whenever disassembled from steering tube for any reason.

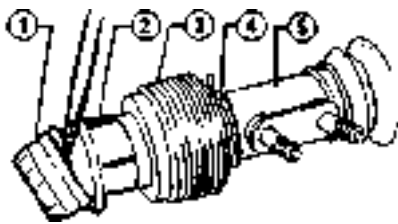

- | | |
|--------------|----------|
| 1 End cap | 4 Clamp |
| 2 Support | 5 Sleeve |
| 3 Right boot | |

3. By means of nut and lock unscrew and extract studs (7), then remove plate (5) and spacer (2) for rod support.
4. Remove clamp (3) fixing left boot (4) and extract it from sleeve (1), then extract sleeve from rack tube.

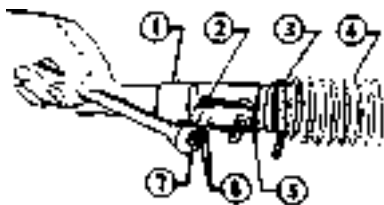

- | | |
|-------------|--------------------|
| 1 Sleeve | 5 Plate |
| 2 Spacer | 6 Nut and lock nut |
| 3 Clamp | 7 Studs |
| 4 Left boot | |

5. Remove the sliding member (2) from rack guide tube (1).

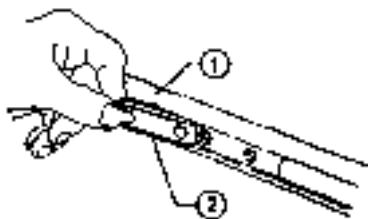

- | | |
|--------|------------------|
| 1 Tube | 2 Sliding member |
|--------|------------------|

6. Remove the cover (1) from rack box (5), screw up and extract adjustment screw (2), spring (3) and plunger (4) for backlash. Then lever with a screwdriver and remove lower protection cap (6) of rack control pinion.

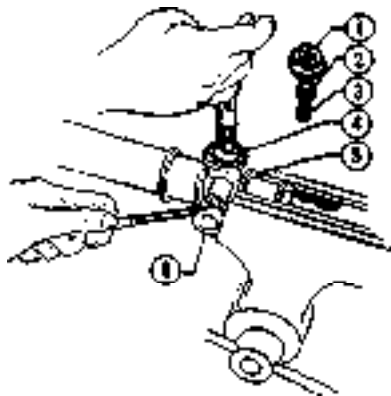

- | | |
|--------------------|-------------|
| 1 Cover | 4 Plunger |
| 2 Adjustment screw | 5 Rack box |
| 3 Spring | 6 Lower cap |

7. Extract rack (1) from guide tube (2).

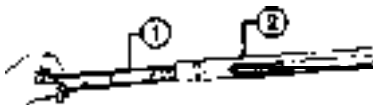

- | | |
|--------|--------------|
| 1 Rack | 2 Guide tube |
|--------|--------------|

8. Remove lock ring (1) fixing pinion bearing to rack box.

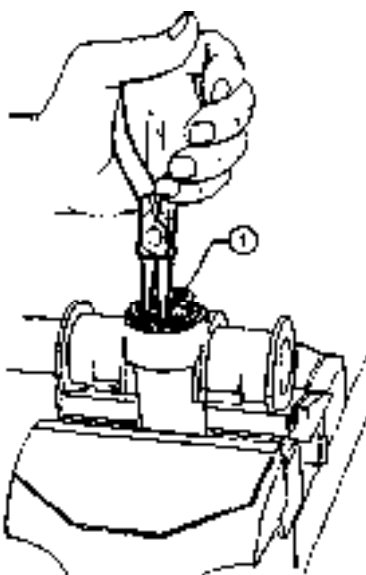

- | |
|-------------|
| 1 Lock ring |
|-------------|

9. Remove pinion from rack box together with the bearings, by means of a plastic hammer and a supporting base.

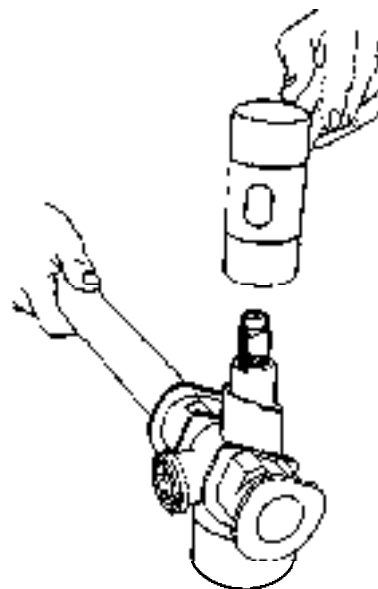

10. Remove lock ring (1) fixing bearing (2) on pinion (3), after placing it in a vice provided with protective jaws.

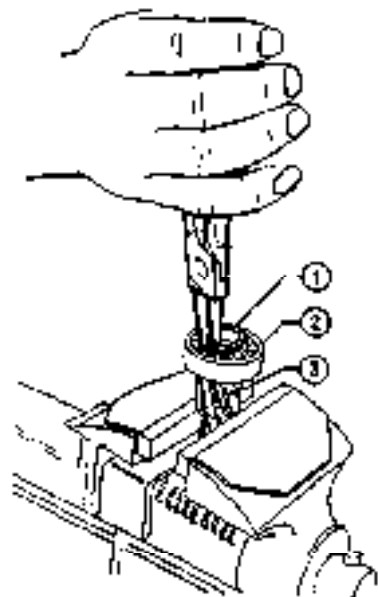

- | | |
|-------------|----------|
| 1 Lock ring | 3 Pinion |
| 2 Bearing | |

11. Disassemble bearing (2) from pinion (1) by means of a punch and a suitable base.

STEERING SYSTEM

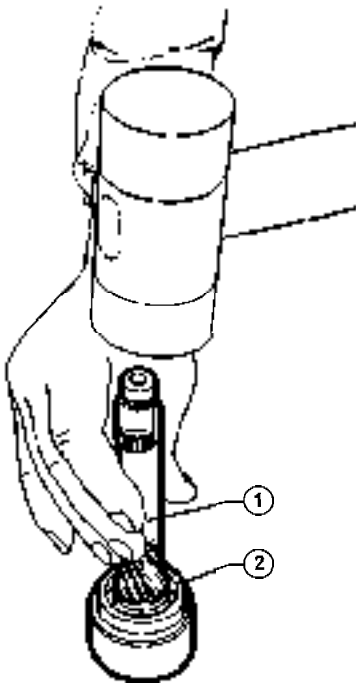

1 Pinion 2 Bearing

3. Provide internal room of steering box with 40 g (1.41 oz) grease (AGIP F1 grease 33 FD or IP Autogrease FD), lubricate pinion bush and assemble pinion by means of a punch, a base and a plastic hammer.

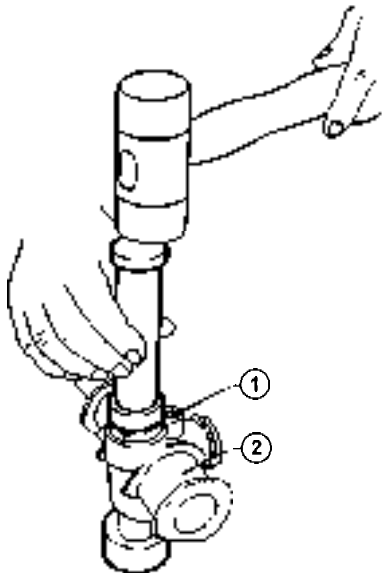

1 Bearing 2 Rack box

4. During assembly use plunger and adjusting screw of the same material (plastic or metal).

5. Lubricate rack with grease (refer

to point 3) and introduce it into the guide tube after rotating pinion, in order to realize, when assembly is ready, reciprocate positioning between rack and pinion verified by dimension "A" with pinion oriented with cutout downwards (obtain angle $\alpha = 90^\circ \pm 26''$).

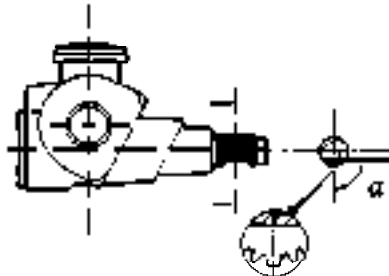

Reference dimension for pinion-rack positioning

$$A = 125\text{mm (4.921 in)}$$

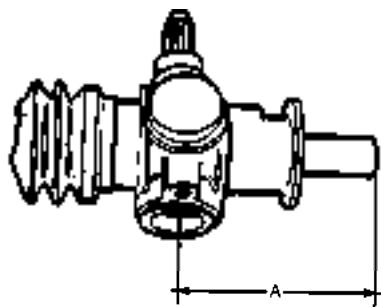

6. Select rack sliding member depending on the available guide tube, as follows:

a. Employment of already existing steering tube.

(1) Check that the sliding member (2) slides the whole steering tube (3) if pushed by hand with a slight stress; by means of a thickness gauge (1) verify backlash "G" between pad and slot does not exceed the recommended value in any position.

Maximum allowed backlash "G" between pad and slot
 $G = 0.1 \text{ mm (} 3.94 \cdot 10^{-3} \text{ in)}$

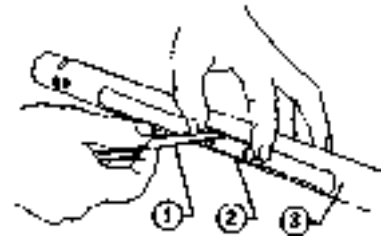

1 Thickness gauge 3 Steering tube
2 Sliding member

(2) In case of defect, select another sliding member from the range of available thicknesses, for the above recommended conditions to be met. (Thicknesses may be distinguished by different-color paint spots on the pads, as follows in increasing order: white - yellow - red green blackish blue).

(3) If tolerance "G" cannot be met with any of the available sliding member, replace steering tube.

b. Employment of a new steering tube.

Replace also the sliding member and use a new one with paint spot of the same color as the steering tube. Maximum backlash in this way is $0.044 \text{ mm (} 1.73 \cdot 10^{-3} \text{ in)}$.

7. Apply 15 g (0.53 oz) of grease, as per item 3, inside the sliding sleeve and lubricate rack tube external surface.

8. Assemble left boot, sliding member, sliding sleeve, then insert studs, spacer and plate. Assemble right boot, a new guide support, checking that the internal tooth fits the tube seat; then place end cap.
 9. Lubricate plunger and backlash adjustment screw with grease recommended at point 3. With rack rod in central position assemble plunger, spring and screw and adjust pinion-rack backlash, as follows.
 (1) By means of spanner A.5.0204, tighten plunger adjustment screw to the indicative torque: 3 N·m (0.3 kg·m; 2.17 ft·lb).

STEERING SYSTEM

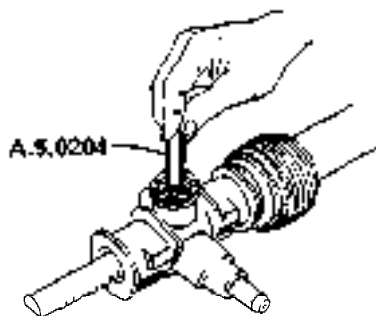

(2) Check with space in the screw is most centered with respect to a notch in the box; loosen screw until the diametrically opposite space to the one centered with the first notch on the box is aligned.

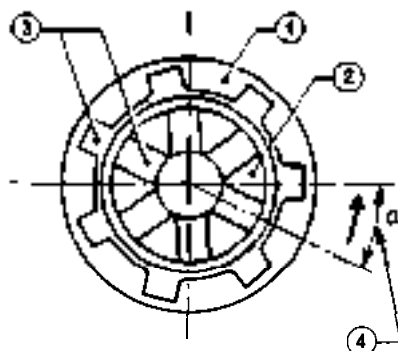

- 1 Steering box
- 2 Adjusting screw
- 3 Aligned space and notch
- 4 Screw rotation

10. Verify that steering pinion rotates up to the rack rod end-of-stroke in both directions smoothly.

11. Tighten boots fixing clamps, for both ends of each boot not to be

rotated with respect to each other, with reference to the boot body junction line.

12. Center steering stroke by obtaining dimension "A" as per figure indicated at step 5.

INSTALLATION

1. Mount steering box assembly on vehicle by tightening securing screws at the prescribed torque $39 \div 48 \text{ N}\cdot\text{m}$ ($4 \div 4.9 \text{ kg}\cdot\text{m}$, $28.92 \div 35.43 \text{ ft}\cdot\text{lb}$). Refit end cap on the rack box.
2. With the wheels in the straight ahead position, mount steering rods and tighten them at the prescribed torque $39 \div 48 \text{ N}\cdot\text{m}$ ($4 \div 4.9 \text{ kg}\cdot\text{m}$, $28.92 \div 35.43 \text{ ft}\cdot\text{lb}$) with vehicle at nominal height.
3. Check toe-out (Refer to: Group 00 - Chassis and Body Maintenance).

SERVICE DATA AND SPECIFICATIONS

GENERAL SPECIFICATIONS

FLUIDS AND LUBRICANTS

Application	Type	Denomination	Q.ty
Column support spacer for hinging to body (external surface)	GREASE	AGIPF1 grease 15 Std. No. 3671-69810	—
Steering column bearings Steering rack rod (ext. surface) Pinion bush Rack-pinion backlash take-up plunger Backlash adjustment screw (on thread)	GREASE	AGIPF1 grease 33 FD IP Autogrease FD Std. No. 3671-69833	—
Rack sliding sleeve (internal surface)			15 g (0.53 oz)
Rack box (int. room)			40 g (1.41 oz)
Side rod silentblock (ext. surface)	FLUID	UNION CARBIDE CHEMICALS COMPANY: Ucon lubricant 50HB - 5100 MILLOIL: lubricant for elastomer seal Std. No. 4500-17502	—

STEERING SYSTEM

INSPECTIONS AND ADJUSTMENTS

1. Dimension "A" for rack rod centering in the steering tube

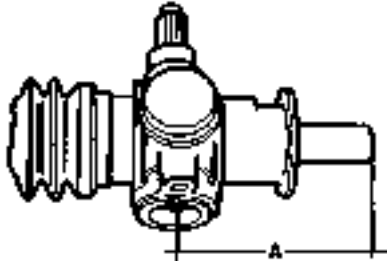

A	mm (in)	125 (4.921)
---	---------	-------------

2. α cutout positioning angle on rack pinion (rack centered as per point 1)

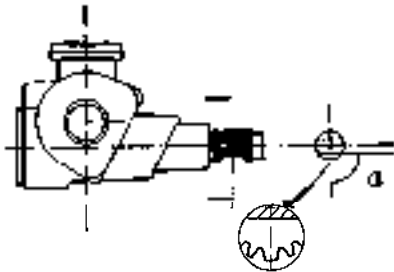

α	degrees	90 ± 26
----------	---------	-------------

3. Light "B" between steering column covers and steering wheel structure

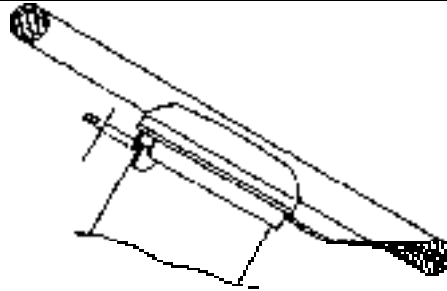

B	mm (in)	0 f 6 (0 ÷ 0.23)
---	---------	------------------

4. Thickness of rack guide pad. The available thickness, in increasing order are provided in the below list (they can be distinguished by the paint mark on pads):
white yellow red green blackish blue

5. Maximum clearance "G" between pad and slot

G	mm (in)	0.1 (0.3·10 ⁻²)
---	---------	-----------------------------

TIGHTENING TORQUES

Item	Unit	N·m	kg·m	ft·lb
Nut securing track rod ball joint to lever on strut		39 ÷ 48	4 ÷ 4.9	28.92 ÷ 35.43
Nut securing steering wheel to steering column		17 ÷ 21	1.7 ÷ 2.1	12.29 ÷ 15.18
Nuts securing track rod to steering box		39 ÷ 48	4 ÷ 4.9	28.92 ÷ 35.43
Bolts securing upper steering column to lower steering column and to steering box pinion		27 ÷ 31	2.7 ÷ 3.1	19.52 ÷ 22.41
Bolt securing steering column lower support to body		14 ÷ 18	1.4 ÷ 1.8	10.29 ÷ 13.01
Nut securing steering column upper support to body (*)		16 ÷ 20	1.6 ÷ 2.0	11.56 ÷ 14.46
Nut for toe-out adjustment on track rod		55 ÷ 69	5.6 ÷ 7	40.49 ÷ 50.61
Screw securing steering box to body		39 ÷ 48	4 ÷ 4.9	28.92 ÷ 35.43



(*) With steering wheel release lever to the locked position

STEERING SYSTEM

TROUBLE DIAGNOSIS AND CORRECTIONS

Condition	Probable cause	Corrective action
Excessive steering wheel backlash	<ul style="list-style-type: none"> • Loose steering box screws • Damaged steering rods or universal joints 	<p>Tighten screws</p> <p>Replace defective components</p>
Column noise in drive	Worn column bearings	Replace bearings
Drive noise	<ul style="list-style-type: none"> • Loose steering box screws • Worn steering levers • Excessive pinion-rack backlash 	<p>Tighten screws</p> <p>Replace defective parts</p> <p>Calibrate backlash</p>
Drive hardening	<ul style="list-style-type: none"> • Inadequate suspension angles • Worn or deflated tyres • Scarce pinion-rack backlash • Scarce lubrication • Damaged universal joints • Interference of column with switch unit 	<p>Restore proper angles</p> <p>Check and restore</p> <p>Calibrate backlash</p> <p>Lubricate</p> <p>Replace joints</p> <p>Calibrate backlash</p>

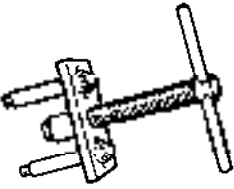
SPECIAL SERVICE > TOOLS

Tool number	Tool name	Refer to page
A.3.0156	Track rod ball joint puller 	23-5
A.3.0461	Steering wheel puller 	23-2
A.5.0204	Spanner for adjustment of steering rack plunger and clearance 	23-10

REAR SUSPENSION

GROUP 25

CONTENTS

DESCRIPTION	25-2	SERVICE DATA AND	
REAR HUB	25-3	SPECIFICATIONS	25-8
Removal	25-3	Technical data	25-8
Checks and inspections	25-4	General specifications	25-9
Installation	25-4	Controls and regulations	25-9
REAR SUSPENSION	25-5	Tightening torques	25-9
Shocks absorbers	25-5	TROUBLE DIAGNOSIS AND	
Coil springs	25-7	CORRECTIONS	25-10
Rear rigid axle	25-7	SPECIAL SERVICE TOOLS	25-11

Refer to Group 00 - Chassis and Body Maintenance
for:

- Rear Axle and Rear Suspension
- Wheel Alignment
- Checking Suspension Height

DESCRIPTION

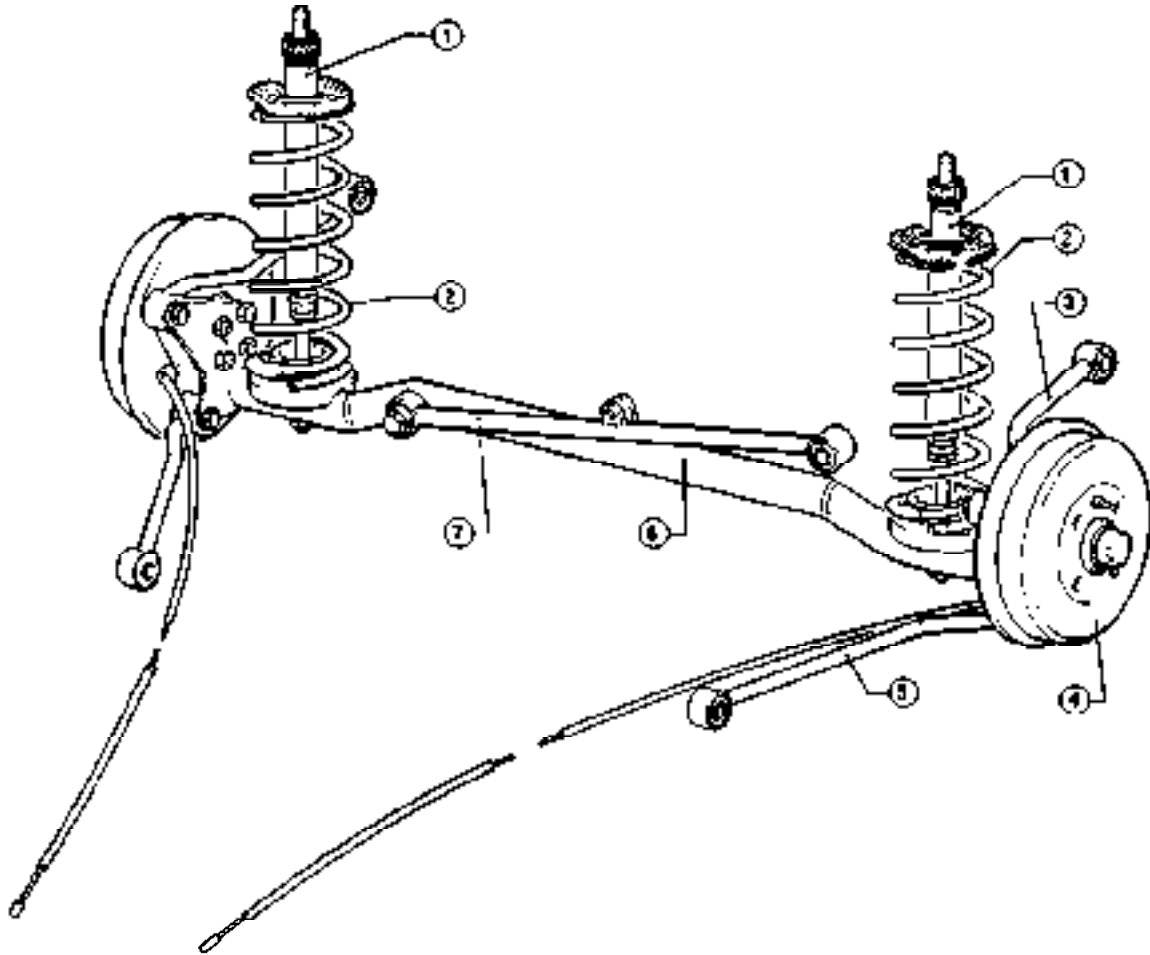

1 Shock absorber
2 Spring
3 Rear tension rod
4 Wheel hub

5 Front tension rod
6 Rigid axle
7 Panhard bar

The rear suspension is a rigid axle one. The axle longitudinal anchorage is carried out by means of two tension rods, on each side, connected to the body and placed according to a Watt parallelogram, so as to limit car raising when braking.

The transversal connection is carried out by means of a tension rod (Panhard bar) anchored on one side to the axle and on the other to the body, in order to prevent body side movements with respect to the wheels.

Between axle and body near the wheel hubs are interposed the suspension springs with coaxial shock absorber. The wheel rebounds are limited by rubber pads assembled on the shock absorber.

REAR HUB

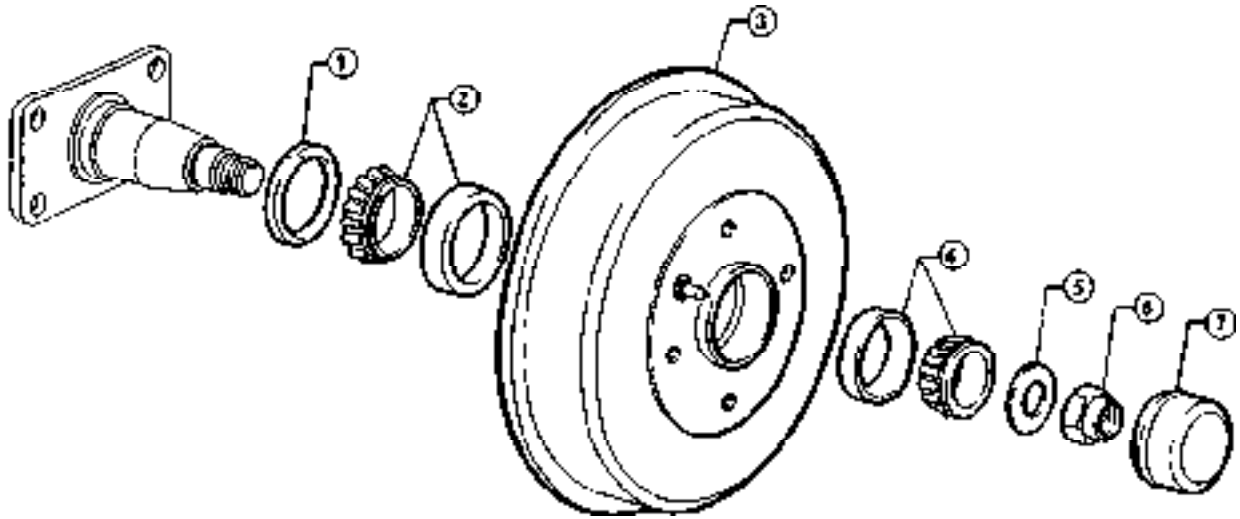

- | | |
|--------------------|-------------|
| 1 Grease seal ring | 5 Washer |
| 2 Inner bearing | 6 Nut |
| 3 Drum | 7 Hub cover |
| 4 Outer bearing | |

REMOVAL

1. Block front wheels with a suitable system, then lift rear part of car and position it on support stands (see: Group 00 - Lifting Points and Towing).
2. Remove wheel from the operative side.
3. Withdraw dust cover from its seat.
4. Operating as per figure, remove wheel hub stop nut caulking and remove it.
5. Move hub with drum, withdraw washer and outer bearing.

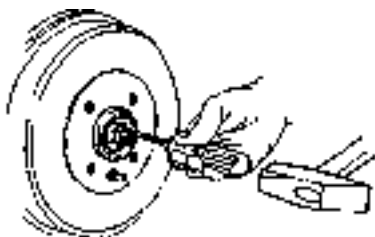

CAUTION:
Do not drop bearing.

6. Operating in bench and using a screwdriver withdraw grease seal ring from hub.
The seal ring must not be reutilized.

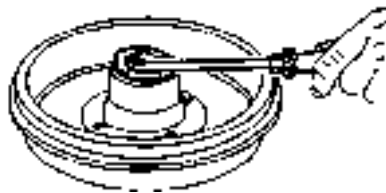

7. Withdraw inner bearing from its seat.
8. Using tool A.3.0349, withdraw from its seat outer ring of outer bearing.

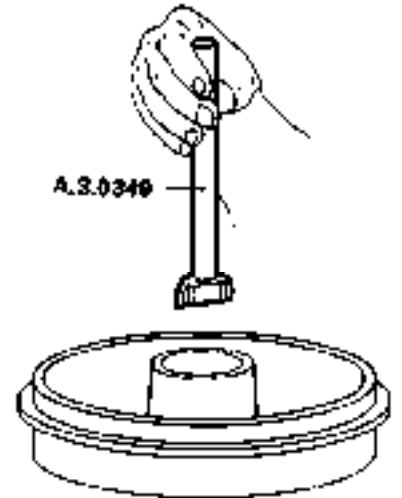

9. Using tool A-3.0355 withdraw from its seat outer ring of inner bearing.

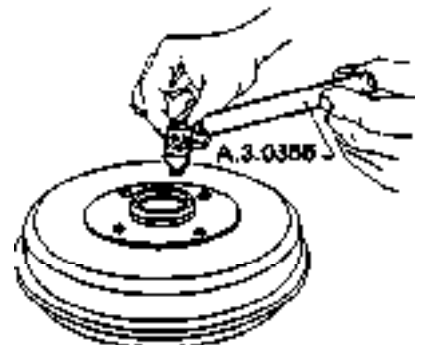

REAR SUSPENSION

CHECKS AND INSPECTIONS

Clean bearings and other details carefully, then dry them with compressed air.

WHEEL BEARING

If the surfaces of tracks and conical rollers present pittings, roughnesses and ovalizations, replace bearing unit.

CAUTION:

Should a bearing be no more utilizable, replace both the inner and the outer one at the same time.

KNUCKLE PIN

Make sure knuckle pin is not damaged and thread is sound; replace pin if necessary (for replacement see: Rigid Axle).

INSTALLATION

1. By using taker-in A-3.0328 assemble outer ring of outer bearing on hub, inserting it wholly in its seat.

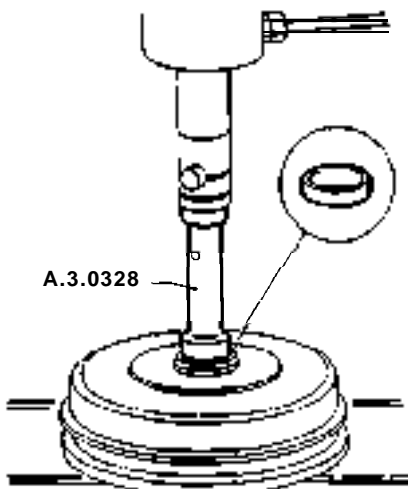

2. By using taker-in A.3.0329, assemble outer ring of inner bearing on hub, inserting it wholly in its seat.

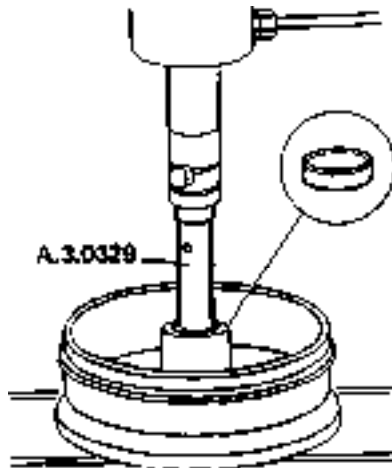

3. Lubricate outer rings of bearings with bearing specified grease (AGIP F1 Grease 33 FD, or IP Autogrease FD), and insert 40 ÷ 55 g. into the hub inner chamber.

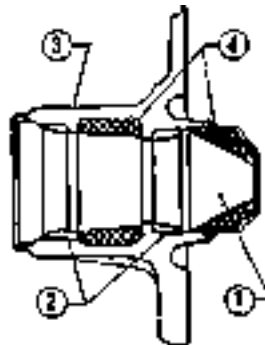

- | | |
|------------------------|----------------|
| 1 Dust cover | 3 Hub |
| 2 Bearings outer rings | 4 Grease rings |

CAUTION:

The grease must not get in touch with drum braking surface.

4. Lubricate hub inner bearing with 9 specified grease and insert into its seat. Lubricate seal ring with specified grease and insert it into its seat on hub by using tool A-3.0459. Lay off a coat of the same grease on the knuckle pin, on its relevant threaded end, on washer and on securing nut.

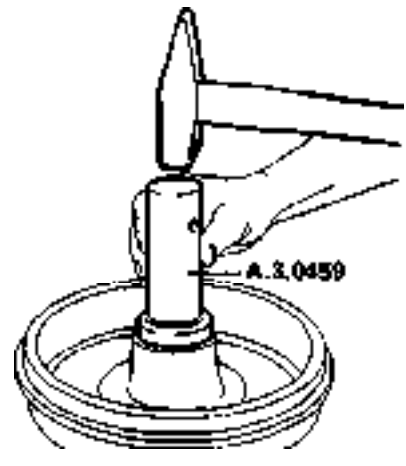

5. Assemble hub on stem pin and then insert outer bearing lubricated with specific grease, washer and new check nut.

6. Carry out wheel bearings preloading adjustment (see: Group 00 Maintenance of Mechanical Components and Body), thenpeen nut.

7. Apply specific bearings grease onto the dust cover lid then assemble it on the stem pin; re-assemble wheel.

REAR SUSPENSION

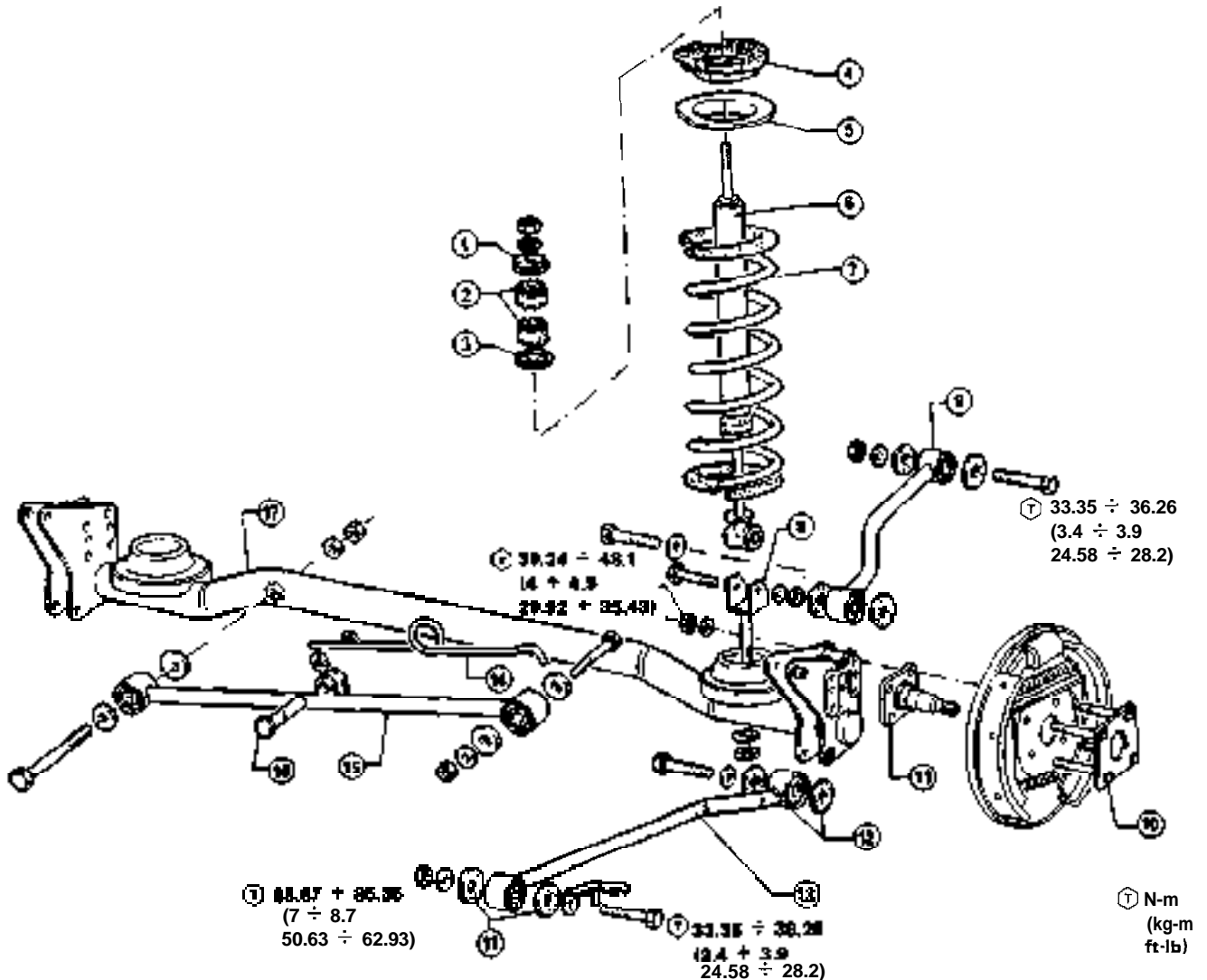

- 1 Upper cup
- 2 Rubber bumpers
- 3 Lower cup
- 4 Upper gasket
- 5 Upper cap
- 6 Shock absorber

- 7 Coil spring
- 8 Shock absorber anchor fork
- 9 Rear tie rod
- 10 Stud plate
- 11 Stem pin
- 12 Gaskets

- 13 Front tie rod
- 14 Brake adjuster
- 15 Panhard bar
- 16 Pin
- 17 Rear axle

SHOCKS ABSORBERS

REMOVAL

After duly blocking front wheels, lifting car front and placing it on supports stands (see: Group 00 - Lifting Points and Towing) remove shock absorbers as follows:

1. Remove wheels.
2. Release bolts ① securing front tie rods ① to body.

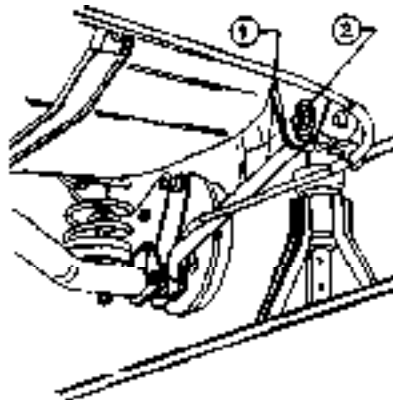

1 Front tie rod 2 Bolt

3. Release bolts ① and bolt ② securing rear tie rods and Panhard bar to body respectively.

REAR SUSPENSION

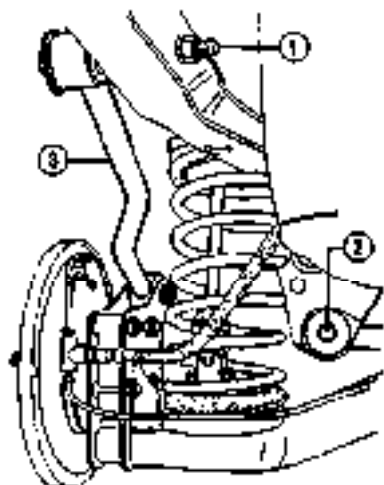

- 1 Bolt
2 Bolt
3 Tie rod

4. Screw out rigid tube connection of brake hydraulic system and extract flexible hose from support square. Apply a cap to rigid tube.

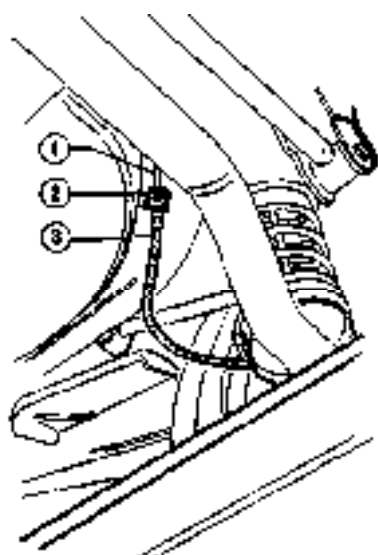

- 1 Rigid tube
2 Square
3 Flexible tube

5. Place column hoist provided with A.2.0070 support under the axle and lift it to release shock absorbers from end-of-stroke.

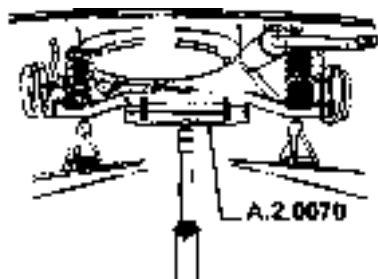

6. From luggage compartment release and remove lock nut and nut of upper shock absorber fastener, the remove cap and anti-shock rubber bumper.

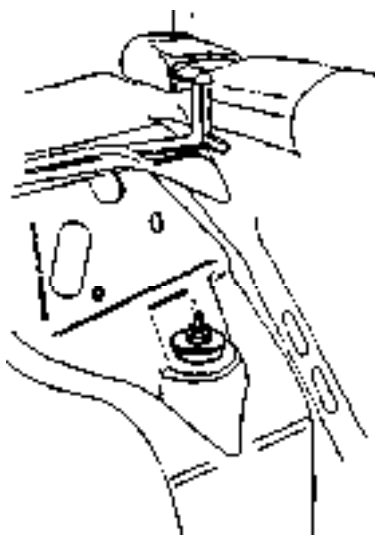

7. Release and remove nuts and washers of lower shock absorber fastener, then lower hydraulic hoist, remove springs from axle and shock absorbers.

8. Separate from shock absorber rubber bumper, cap, and attaching fork, after removing the relevant fastening screw.

CHECKS AND INSPECTIONS

1. Check shock absorber efficiency and replace it, if oil leaks are found.
2. If necessary, verify shock absorber calibration data (see: Service Data and Specifications - inspection and Adjustment); replace shock absorbers, if required.
3. Check wear status, damages and deformations of rubber components. Replace them, if required.

INSTALLATION

Assemble shock absorbers on car in the inversed order with respect to removal and remember the following indications:

- a. Assemble shock absorber components and secure their upper part to the body.

- b. Insert springs coaxially to the shock absorbers and make sure caps and upper spring support gaskets are properly assembled and positioned.

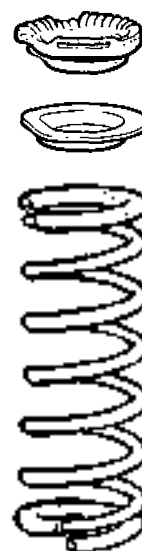

- c. Set up car in nominal position, corresponding to static load (see: Group 00 Maintenance of Mechanical Components and Body) and set the bolts securing tie rods and Panhard bar to body to the prescribed torque.

T : Tightening torques

Bolts securing tie rods to body
 $33.35 \div 38.26 \text{ N}\cdot\text{m}$
 $(3.4 \div 3.9 \text{ kg}\cdot\text{m})$
 $25.28 \div 28.2 \text{ ft}\cdot\text{lb}$

Bolts securing Panhard bar to body
 $68.67 \div 86.35 \text{ N}\cdot\text{m}$
 $(7 \div 8.7 \text{ kg}\cdot\text{m})$
 $50.63 \div 62.93 \text{ ft}\cdot\text{lb}$

- d. Restore rear brake oil delivery tube connection and perform brake system air bleeding (see: Group 22 - Front and Rear Brakes - Brake Air Bleeding).

COIL SPRINGS

REMOVAL

Remove coil springs with the same procedure followed for removal of shock absorbers; only remember not to disjoin shock absorber from upper body coupling.

CHECKS AND INSPECTIONS

1. Verify the springs has no stretches or deformations.
2. Verify spring efficiency by comparing its stiffness values with the prescribed ones (see: Service Data and Specifications).
3. Check wear status, verify presence of damages or deformations of rubber components. Replace if necessary.

INSTALLATION

Assemble coil springs onto car again in the inversed order of removal and bear in mind all indications and notes reported in paragraph Shock Absorbers Installation.

REAR RIGID AXLE

REMOVAL AND INSTALLATION

Place car on hoist bridge, support its rear part by placing some stands in the jack seats and remove the whole rear suspension as follows.

1. Remove wheels.
2. Working from passenger compartment, remove rear console for parking brake equalizer to be accessible. Then act on adjustment fork nut and lock nut and loosen parking brake control cables as much as to allow their releasing from equalizer; extract them from sheath locking bracket.
3. After providing the column hoist with support A.2.0070, remove coil springs with caps and gaskets (see: Coil Springs - Removal).

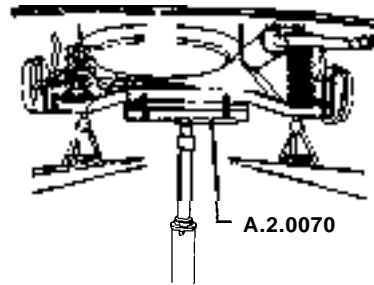

4. Slightly lift column hoist and remove the previously loosened tie rod and Panhard bar bolts.
5. Slowly lower hoist driving the axle and extracting the brake adjustment spring from stud on the Panhard bar.

Assemble again the whole suspension on the car by the inversed procedure than for removal.

IMPORTANT

- With static load car (see: Group 00 - Maintenance of Mechanical Components and Body) set the bolts securing tie rods and Panhard bar to the prescribed torque.

T : Tightening Torque
Tie rod and Panhard bar securing bolts
33.35 ÷ 38.26 N·m
(3.4 ÷ 3.9 kg·m)
24.58 ÷ 28.2 ft·lb)

- Lubricate with prescribed grease (AGIPF1 Grease 15) the hole in the brake adjustment spring support stud on the Panhard bar and the fork.
- Carry out brake adjustment spring calibration (see: Group 22 - Brake Adjustment).
- Set the brake hydraulic system connections to the prescribed torque and perform air bleeding (see: Group 22 - Brake System Air Bleeding).

T : Tightening Torque
Rigid tube connections
7.85 ÷ 9.8 N·m
(0.8 ÷ 1 kg·m)
5.78 ÷ 7.23 ft·lb)

Flexible hose connections
9.8 ÷ 14.7 N·m
(1 ÷ 1.5 kg·m)
7.23 ÷ 10.85 ft·lb)

- Adjust parking brake lever stroke (see: Group 00 - Maintenance of Mechanical Components and Body).

REMOVAL

If necessary, disassemble axle as follows:

1. Release and remove bolts securing tie rods to axle; remove tie rods.
2. If necessary, disassemble silent blocks from tie rods and Panhard bar by using adequate bases and extractors.

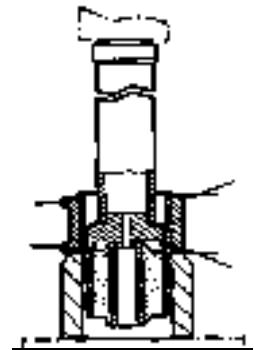

3. Extract dust cover from brake drum and caulk wheel hub nut. Remove nut and drum complete with hub and bearings.
4. Screw out connection (2) of brake hydraulic system rigid tube on jaw control cylinders and remove rear tubes (4).
5. Screw out and remove nuts (3) fastening stem pin and brake shoe plate (1) to rear axle.

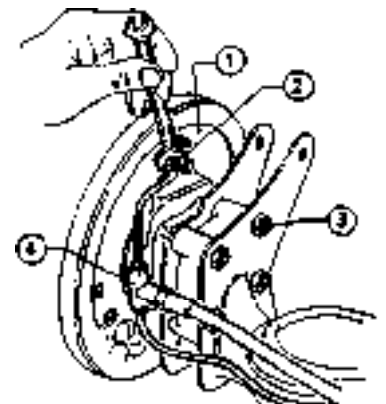

1 Block shoe plate 3 Nuts
2 Connection 4 Rear tubes

REAR SUSPENSION

NOTE FOR CAR OVERLOADED ON REAR AXLE

Should high overloads be applied to the rear axle, like in the case of gas installation. the series rear springs can be replaced on sedan versions with springs having part number 705.507, in case of overload of about 980 N (100 kg)(220.46 lb) with respect to static load, they allow a "rear position" level increased by about 15 mm (0.59 in) with respect to the one indicated in Group 00 - Checking Wheel Alignment.

GENERAL SPECIFICATIONS

FLUIDS AND LUBRICANTS

Application	Type	Denomination	Q.ty
Wheel hub inner cavity and dust cover Seal ring rim Bearing inner rings and relevant outer races Bearing housings on pin	GREASE	AGIPF1 Grease 33 FD IP Autogrease FD Std. No. 367 I-69833/34	40 ÷ 55 g 1.41 ÷ 1.94 oz.
Internal diameter of hole in brake adjustment spring support stud on Panhard bar. Brake adjustment fork	GREASE	AGIPF1 Grease 15 Std. No. 3671-69810	
Tie rod end (front and rear) silentblock outer surface and Panhard bar (at assembly) Outer surface of rubber bound bumper (at shock absorber assembly)	FLUID	UNION CARBIDE CHEMICALS CO. Ucon Lubricant 50 HB-5100 MILLOIL Lubricant for elastomer seal Std. No. 4500-17502	
Outer surface of wheel hub seal ring	OIL	AGIPF1ROTRA MP SAE SOW90 IP Pontiac HD 80W90 Std. No. 3631-69408	

CONTROLS AND REGULATIONS

STEERING GEOMETRY

(See: Group 00 - Rear Axle and Suspension)

WHEELS BEARINGS PRELOADING ADJUSTMENT

(See: Group 00 - Rear Axle and Suspension)

REAR SUSPENSION

DATA FOR SHOCK ABSORBER CALIBRATION

Alfa Romeo Part Number			542.147
Low speed	Compression	N (kg) (lb)	5.9 ÷ 14.7 (6 ÷ 15) (13.23 ÷ 33.07)
	Extension	N (kg) (lb)	7.8 ÷ 17.7 (8 ÷ 18) (17.64 ÷ 39.68)
High speed	Compression	N (kg) (lb)	27.5 ÷ 41.2 (28 ÷ 42) (61.73 ÷ 92.59)
	Extension	N (kg) (lb)	6.38 ÷ 8.34 (6.5 ÷ 8.5) (14.33 ÷ 18.739)

NOTE: Values to be measured with shock absorbers at 20 ± 2°C (68 ± 3.6°F) temperature

TIGHTENING TORQUES

Item	Unit	N-m	kg-m	lb-ft
Bolts securing Panhard bar to body		68.67 ÷ 86.35	7 ÷ 8.7	50.63 ÷ 62.93
Bolts securing front and rear tie rods to body		33.35 ÷ 38.26	3.4 ÷ 3.9	24.58 ÷ 28.2
Bolts securing stem pin to axle		39.24 ÷ 48.1	4 ÷ 4.9	29.92 ÷ 35.43
Brake hydraulic system rigid tube connections		7.85 ÷ 9.8	0.8 ÷ 1	5.78 ÷ 7.23
Brake hydraulic system flexible hose connections		9.8 ÷ 14.7	1 ÷ 1.5	7.23 ÷ 10.85

TROUBLE DIAGNOSIS AND CORRECTIONS



When rear suspensions are suspected of being noisy, carry out a careful check to determine if the noise actually originates in the rear suspensions or if it is due to the tires, road surface, exhaust system, engine, transaxle or wheel bearings.

Condition	Probable cause	Corrective action
Noise	<ul style="list-style-type: none"> • Loose wheel screws • One or more attaching bolts loosen • Lack of lubricating grease on bearings • Faulty shock absorber • Damaged or worn wheel bearing • Wheel and tire out-of-balance • Damage to rubber parts such as lower arm bushing 	<p>Tighten to specified torque</p> <p>Tighten to specified torque</p> <p>Lubricate as required</p> <p>Replace</p> <p>Replace</p> <p>Balance</p> <p>Replace damaged parts</p>

REAR SUSPENSION

Condition	Probable cause	Corrective action
<p>Instability in driving. This trouble is also related to front suspensions. For trouble diagnoses also refer to Group 21</p>	<ul style="list-style-type: none"> • Loose wheel screws • Shock absorber malfunction • Incorrect steering geometry • Yielded coil spring • Damaged tie rod silent-blocks • Loosen tie rod connections 	<p>Tighten to specified torque</p> <p>Repair or replace</p> <p>Yielded coil springs</p> <p>Replace</p> <p>Replace</p> <p>Tighten or replace</p>

SPECIAL SERVICE TOOLS

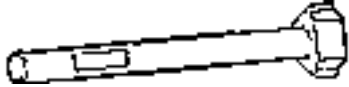
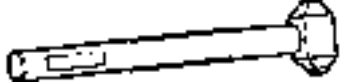
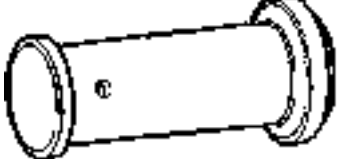
Tool number	Tool name	Refer to page
A.2.0070	Rear axle support 	25-6 25-7
A.3.0328	Driver of rear hub outer conical bearing outer race 	25-4
A.3.0329	Driver of rear hub inner conical bearing outer race 	25-4
A.3.0349	Hub outer bearing outer race extractor 	25-3
A.3.0355	Hub inner bearing outer race extractor 	25-3
A.3.0459	Driver of front hub seal 	25-4

WHEELS AND TIRES

GROUP 28

CONTENTS

CHECKING TIRE CONDITIONS	28-2	CHECKING WHEEL CONDITIONS ...	28-4
Checking tire	28-2	Wheel balance	28-4
Tire inflation	28-2	SERVICE DATA AND	
Tire rotation	28-3	SPECIFICATIONS	28-5
TIRE REPLACEMENT	28-3	General specifications	28-5
Replacement	28-3	Inspections and adjustments	28-5
Wheel screw	28-4	Technical data	28-6

CHECKING TIRE CONDITIONS

CHECKING TIRE

1. Check tread thickness. If below min. allowed limit (1 mm; 0,04 in.) replace tires.

If tires are provided with "tread wear indicator", when marks appear, replace tires.

2. Remove pebbles, glass or any other foreign material embedded in the threads.
3. Check tread and side walls for cracks, holes, separation or damage.
4. Check tire valves for air leakage.

TIRE INFLATION

1. Check tire pressure. If necessary, adjust it to specified value.

Tire pressure should be measured when tire is cold.

2. After inflating tires, check valves for leakage. Whenever tire pressure is checked, be sure to tighten valve caps firmly by hand to keep dust and water out.

Abnormal tire wear

Correct abnormal tire wear according to below chart.

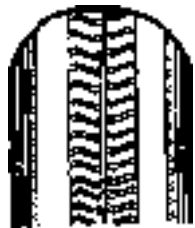
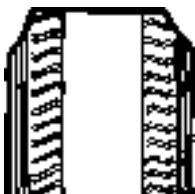
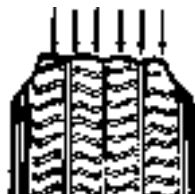
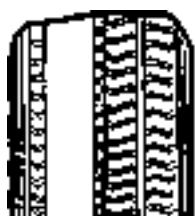
Trouble	Probable cause	Corrective action
 <p>Shoulder wear</p>	<ul style="list-style-type: none"> ▸ Underinflation (both sides wear) ▸ Hard cornering ▸ Lack of rotation 	<p>Check and adjust pressure</p> <p>Reduce speed</p> <p>Rotate tires</p>
 <p>Center wear</p>	<p>Overinflation</p>	<p>Check and adjust pressure</p>
 <p>Toe-in or toe-out wear</p>	<p>Incorrect toe-in or toe-out</p>	<p>Adjust as required</p>
 <p>Uneven wear</p>	<ul style="list-style-type: none"> ▫ Unbalanced wheel • Malfunctioning dampers • Lack of rotation 	<p>Balance or replace</p> <p>Replace dampers</p> <p>Rotate tires</p>

TIRE ROTATION

Operation to be carried out every 5,000 km (3,107 miles).

1. Tires tend to wear unevenly and become unbalanced after a certain running distance. Uneven tire wear often results in problems that, however, one tends to think as being caused by other car components. Front tires also tend to wear unevenly because of improper alignment of front wheels.

2. Therefore, to equalize tire wear, it is necessary to rotate tires periodically. Following are some different allowed arrangements for tire rotation.

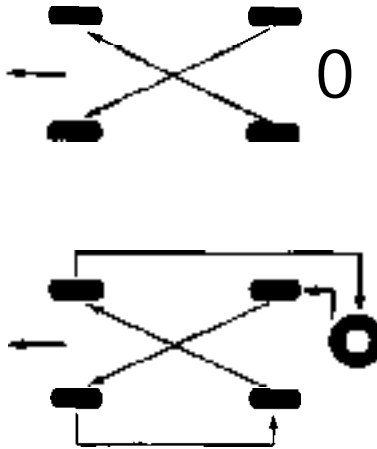

TIRE REPLACEMENT

CAUTION:

Different types of tires, such as bias, bias belted and radial tires, must not be under any circumstances. Different types of tires can adversely affect vehicle handling and may cause driver to lose control.

- a. When replacing a worn or damaged tire, use a replacement tire of the same size and load carrying capacity as that with which the car was originally equipped with by the Manufacturer. The use of tires having different size and/or load capacity than those approved by the manufacturer is not allowed since it changes the car's technical characteristics.
- b. For the same above mentioned reasons, do not use tires and wheels other than those recommended, and do not mix tires of different brand or tread pattern. The use of tires and wheels other than those recommended or the

adversely affect riding, braking, handling, ground clearance, body-to-tire clearance, and speedometer calibration.

- c. It is recommended to fit new tires in pairs on the same axle. When replacing only one tire, it should be paired with the one having the most tread in order to equalize braking action.
- d. When replacing tires refer to the procedure described in the relevant paragraph: "Replacement".

2. After having positioned the wheel, fit the four screws properly into place.
3. Tighten screws by hand as far as possible keeping the wheel in correct position
4. Tighten wheel screws with proper wheel wrench in crisscross and progressive fashion.

REPLACEMENT

1. To replace a tire using a jack in a safe manner, refer to: Lifting Points for jacking up.

WARNING:

Never get under the vehicle while it is supported only by jack. Always use safety stands to support side member of body construction when you must get beneath the

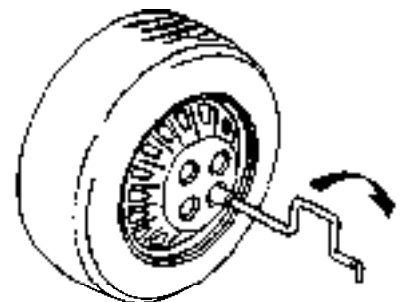

Be sure to check wheel screws for tightness, after the wheel has been run for the first 1,000 km (621 miles); do the same thing in case of

WHEEL SCREW

CAUTION:

Two types of wheel screws are used: one is designed for use with steel wheels and the other for use with light alloy wheels. Do not mix different type wheel screws.

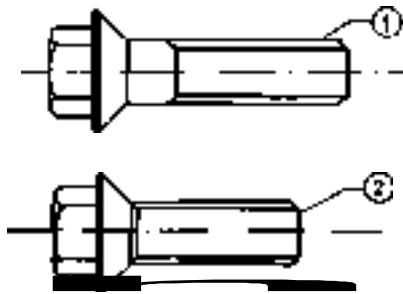

Be careful not to smear threaded portion of screw not relevant seat with oil or grease.

- 1 Screw for light alloy type wheels
- 2 Screw for steel type wheels

CHECKING WHEEL CONDITIONS

Inspect wheels thoroughly paying special attention to the following points, in order to ensure satisfactory steering condition as well as maximum tire life. If any defect is present, repair or replace as required.

1. Check wheel rim, especially rim flange and bead set, for rust, distortion, cracks or other faults which might cause air leaks. Proper functioning of tubeless tires depends on effective sealing between tire bead and wheel rim.
2. Thoroughly remove rust, dust, oxidized rubber or sand from wheel rim.
Rim's bead seats should be suitably cleaned (for ex. using neutral type detergent, cloth, etc...) being careful not to damage the wheel surfaces protecting film.
3. Replace wheel when any of the following occurs:
 - Bent, dented or heavily rusted wheel
 - Bolt holes are out-of-round
 - Excessive side or radial runout
 - Air leaks through welds

WHEEL BALANCE

Inspect wheel and tire for proper wheel balance; if unbalanced, correct

it taking the following points into consideration:

1. Correct unbalance as soon as relevant symptoms appear such as wheel tramp and shimmy.
2. Balance wheel with tire both statically and dynamically.

WHEEL BALANCING PROCEDURE

CAUTION:

Considering the special construction features of the differential assembly, it is imperative that balancing of wheels - especially of front ones - be performed according to the procedure hereafter described in order to avoid serious damage.

Front wheels

1. Lift car front with a dolly-type hydraulic jack placing same under relevant lifting point (Refer to: Lifting Points for jacking up).
2. Place two stands in line with front jacking points located under car body.
3. Lower car till it rests on stands but locking the jack as well (thus achieving a three-point support).

4. Lock rear wheels by means of two wedges, one for each wheel.
5. Set up balancing machine and auxiliary equipment; make sure indicating finger is placed under suspension's cross arm and in line with the arm-wheel support joint.
6. Start up the engine, engage 4th speed and then rev engine up to max. speed as per speedometer reading.
7. Perform wheel balancing according to usual "Equitron" type balancing machine procedure.

Rear wheels

1. Lock front wheels by means of two wedges, one for each wheel.
2. Lift car rear, inserting jack under axle. Position two stands in correspondance with stand rear seats and then lower the car.
3. Set up balancing machine and auxiliary equipment; make sure probe is placed under the suspension spring. Let the wheel rotate by means of a wheel accelerator device, then carry out balancing operations with the modalities for balancing machine of the "Equitron" type.

WHEELS AND TIRES

BALANCE WEIGHTS POSITIONING

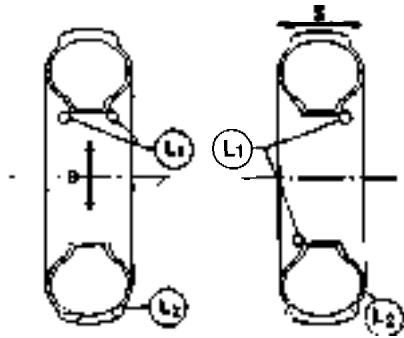

L₁ = location of balance weights
D = tramp direction
S = shimmy direction
L₂ = location of unbalance causing heavy area



1. Balance weights

Maximum allowable at rim flange:
8 g (0.28 oz)

Balance weights:
10 ÷ 40 (0.35 ÷ 1.40 oz)
at 10 g (0.35 oz) interval

- a. Be sure to place correct balance weights on inner edge of rim.
- b. Do not pure more than two weights on each side.
- c. Two types of balance weights are used: one is designed for use with steel wheels and the other for use with light allowy wheels. Do not mix different type balance weights.
- d. Properly rebalance wheel and tire whenever puncture is repaired.

SERVICE DATA AND SPECIFICATIONS

GENERAL SPECIFICATIONS

FLUIDS AND LUBRICANTS

Application	Type	Denomination	Q.ty
Tire beads	FLUID	UNION CARBIDE CHEMICALS COMPANY: Ucon lubricant 50 HE-5100 MILLOIL: lubricant for elastomer seals Stel. No. 4500-17502	

INSPECTIONS AND ADJUSTMENTS

DYNAMIC BALANCE

Max. allowed residual unbalance.	8 g (0.280 oz)
Thread thickness limit	1 mm (0.04 in)
Wheel screws tightening after the first	1,000 km (621 miles)
Balance weights (at 10 g (0.35 oz) interval)	10 ÷ 40 g (0.35 ÷ 1.40 oz)

TECHNICAL DATA

ENGINE		1200		1350		1500		
MODEL IDENTIFICATION No.		806.08		805.02 806.03		805.04 805.06 805.07		
TIRE	RIM	UNIT OF MEASURE	INFLATING PRESSURE (**)					
			A	P	A	P	A	P
Microlin XZX TBI 165/70.13	S.R. 5 J x 13 H2 (1)	kg/cm ²	1.8	1.6	1.8	1.6	1.8	1.6
Firestone ST TBI 165/70.13	S.R. 5 J x 13 H2 (1)	bar	1.76	1.57	-	-	-	-
Firestone ST TBI 165/70.13	S.R. 5 J x 13 H2 (1)	kPa	178	157	-	-	-	-
Firestone ST TBI 165/70.13	S.R. 5 J x 13 H2 (1)	p.s.i.	25.6	22.76	-	-	-	-
Pirelli P3 Cinturato TBI 165/70.13	S.R. 6 J x 13 H2 (1) 6 1/2 J x 13 CH (2)	kg/cm ²	1.8	1.6	1.8	1.6	1.8	1.6
Pirelli P3 Cinturato TBI 165/70.13	S.R. 6 J x 13 H2 (1) 6 1/2 J x 13 CH (2)	bar	1.76	1.57	1.76	1.57	1.76	1.57
Pirelli P3 Cinturato TBI 165/70.13	S.R. 6 J x 13 H2 (1) 6 1/2 J x 13 CH (2)	kPa	176	157	176	157	176	157
Pirelli P3 Cinturato TBI 165/70.13	S.R. 6 J x 13 H2 (1) 6 1/2 J x 13 CH (2)	p.s.i.	25.6	22.76	25.6	22.76	25.6	22.76
Good Year Grand Prix S TBI 165/70.13	S.R. 6 J x 13 H2 (1) 6 1/2 J x 13 CH (2)	kg/cm ²	-	-	-	-	-	-
Good Year Grand Prix S TBI 165/70.13	S.R. 6 J x 13 H2 (1) 6 1/2 J x 13 CH (2)	bar	-	-	-	-	-	-
Good Year Grand Prix S TBI 165/70.13	S.R. 6 J x 13 H2 (1) 6 1/2 J x 13 CH (2)	kPa	-	-	-	-	-	-
Good Year Grand Prix S TBI 165/70.13	S.R. 6 J x 13 H2 (1) 6 1/2 J x 13 CH (2)	p.s.i.	-	-	-	-	-	-
Balance (max. allowed residual balance)		g (oz)	± 10 (± 0.35)					
Balance weights		g (oz)	± 10 (± 0.35)					
Chain "S" max. dimensions		mm (in)	16 (0.63)					

A = Front
P = Rear
N = With reduced load and touring riding
V = With full load and steady top speed riding
 S.R. rating = Up to 180 mph (120 m.p.h.)
 (***) Inflation pressures measured with cold tires.
 In particularly heavy operating conditions (max. load, high temperatures, high speeds, etc.....) it is advisable to increase inflation pressures by 0.2 kg/cm² (0.7 bar : 20 kPa ; 2.84 p.s.i.)
 In the event of rear axle overloading (rear housing, L.F.G. tank, etc.....) it is advisable to increase rear tires inflation pressures by 0.6 kg/cm² (0.6 bar : 60 kPa ; 8.63 p.s.i.)

ELECTRICAL SYSTEM

GROUP 40

CONTENTS

HOW TO READ THE WIRING		
DIAGRAM	40-2	
Wiring diagram	40-2	
Power supply routing	40-3	
POWER SUPPLY ROUTING	40-4	
Schematic/Power supply routing . . . ●	40-4	
Fuses	40-5	
Ignition switch	40-6	
ELECTROMECHANIC AND		
ELECTRONIC DEVICES	40-7	
Relays and timer	40-7	
Electronic devices and intermittence;	40-7	
LIGHTING SYSTEM	40-10	
Lamps	40-10	
Combination switch assembly	40-11	
Outside lighting	40-13	
Front combination lamps	40-17	
Rear combination lamps	40-19	
Inside lighting	40-20	
BOARD INSTRUMENTS AND		
TRANSMITTERS	40-22	
Cluster	40-22	
Engine cooling and lubrication , , .	40-24	
Fuel supply, brake and clutch oil		
minimum level transmitter, tachy-		
metric pulse generator	40-26	
WINDSCREEN WASH/WIPER AND		
HEADLIGHT WASH/WIPER	40-28	
Windscreen wash/wiper	40-28	
Windscreen wiper	40-29	
Headlight wash/wiper	40-32	
Headlight wiper	40-33	
Windscreen washer and headlight		
washer	40-34	
ELECTRIC ACCESSORIES	40-36	
Horns, heated rear window, cigar		
lighter, clock	40-36	
Horns	40-37	
Heated rear window	40-38	
Power window	40-39	
Power windows and door locks . . . ,	40-41	
Door lock control unit	40-42	
Check Control and Trip Computer. .	40-43	
ELECTRIC COMPONENT LOCATION.	40-45	
Engine compartment	40-45	
Passenger compartment	40-45	
HARNES LAYOUT	40-46	
General harness	40-46	
Engine compartment	40-46	
Passenger compartment and luggage		
room (LH)	40-47	
Dashboard (LH)	40-48	
SWITZERLAND-AUSTRALIA MODEL		
VARIATION	40-49	
Tachymetric control unit - fast idle.		
electromagnet - hand brake switch. .	40-49	
CI RCUIT DIAGRAM	40-50	

ELECTRICAL SYSTEM

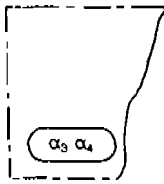

The chain line, on wiring diagram, delimits those areas containing the specific variations for the models indicated by "a...".

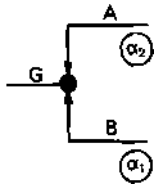

The connection identifies two wiring variations, present in alternative and connected in the same way. The wiring variations are referred to the models indicated by "a...".

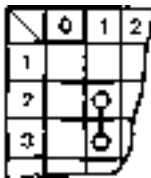

In the horizontal line, table shows position of control or of switch to be operated. In the vertical line it shows the terminals between which continuity generates.

POWER SUPPLY ROUTING

This type of diagram is helpful in identification of specific troubles relevant to the part of electric diagrams concerning supply i.e.: the windscreen wiper is not functioning. A first check' shows efficiency of instrumentation supply. From distribution diagram it can be noted

The example shows continuity between terminals 2 and 3 with the control set to position 1.

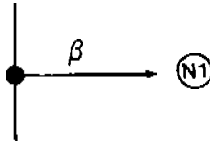

The detail shows a reference to knot relevant to electronic device N ...

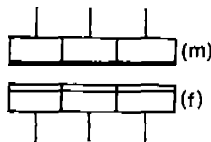

The figure shows the type of diagram used to identify the two connectors relevant to each joint: for the male connector it is applicable diagram (m); for the female one it is applicable diagram (f).

Cable colors

A	Light blue
AB	Light blue - white
AN	Light blue - black
AR	Light blue - red
B	White
BN	White -black
BR	White red
BLN	Blue - black
BLR	Blue - red

C	Orange
CN	Orange - black
CB	Orange -white
H	Grey
HG	Grey - yellow
HN	Grey - black
HR	Grey - red
HV	Grey - green
G	Yellow
GB	Yellow-white
GN	Yellow - black
GR	Yellow - red
GV	Yellow - green
N	Black
NZ	Black - violet
M	Brown
MB	Brown -white
MG	Brown - yellow
R	Red
RN	Red - black
S	Pink
SB	Pink -white
SN	Pink - black
V	Green
VB	Green -white
VN	Green -black
Z	Violet
ZN	Violet - black

In case of mixed color, the base color is indicated first, followed by the present stripe color.
i.e. BN = White with Black stripes

Cable section

Cable section not indicated is 0.5 mm^2 ($0.39 \cdot 10^{-3} \text{ in}^2$).

that supply of both instrumentation and windscreen wiper are realized via ignition switch and fusebox. The result is then that ignition switch operates correctly and no failure is present along wiring between battery and switch itself.

Failure must then be due either to fusebox (see.: Fuses- Services protected by fuses) or to the following parts of the electric system, that is in the wiring windscreen wiper or in the ground connection.
For fault identification, refer then to the windscreen wiper wiring diagram.

POWER SUPPLY ROUTING

SCHEMATIC/POWER SUPPLY ROUTING

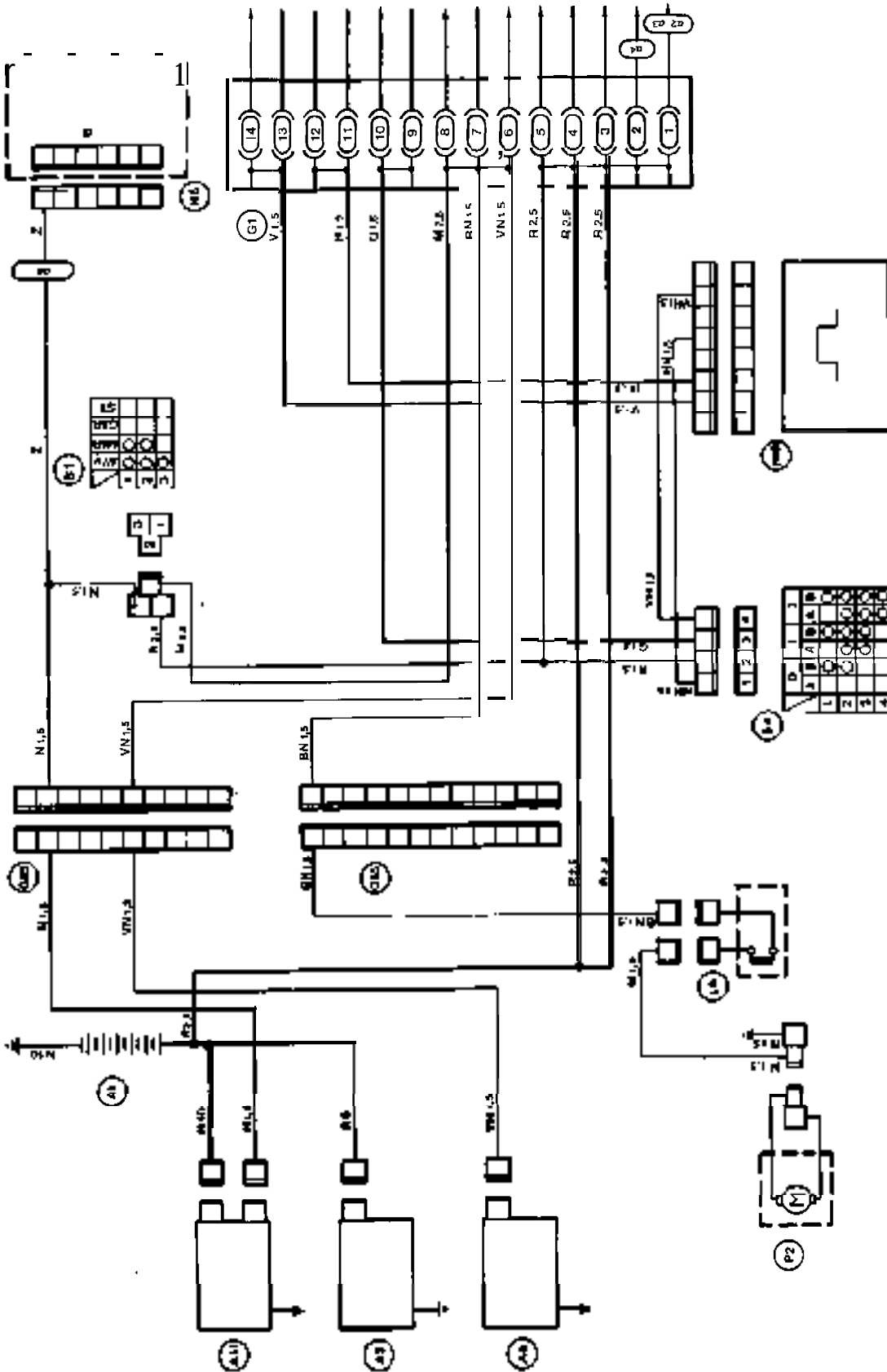

- A1 Battery
- A3 Alternator with built-in electronic regulator
- A8 Ignition coil
- A11 Starter
- B1 Ignition switch
- B4 Control switch for headlights, flashing left beam and right beam
- G1 Fusebox
- Q3 Front service connectors
- L6 Thermostatic switch for engine cooling electric fan
- N6 Check Control
- M18 Electronic device for head lights and fan relay changeover
- P2 Engine cooling electric fan
- Q3 R.H.D. - L.H.D. 1500 model
- Q4 R.H.D. - L.H.D. 1500 Quadrifoglio model

ELECTRICAL SYSTEM

FUSES

LOCATION

The fusebox is integral part of the support board and is located on left side of the intermediate bulkhead, in the engine compartment.

CHECK

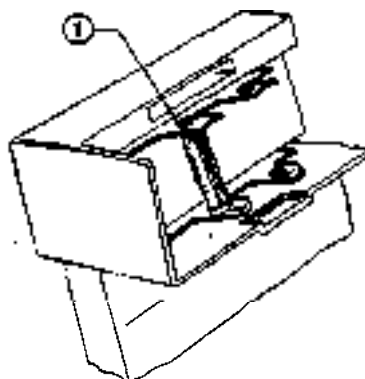

1 Fuse

CAUTION:

- a. In case a fuse blows, before replacing it, make sure that the cause of failure has been removed.
- b. Use fuse having the prescribed amperage, only. Do never use fuses having amperage greater than the prescribed one.
- c. Correctly insert fuse into fuse-box, aligning it carefully with respect to its seat.
- d. Should car remain stationary for a long time, remove fuse protecting supply circuit of clock.

SERVICES PROTECTED BY FUSES

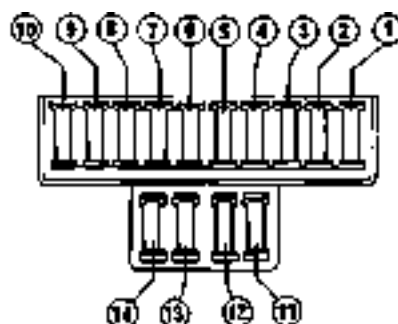

In the following table, for each model, it is specified which are the services protected by each fuse.

Fuse	Protected Service	Ampere	Model			
			1200 905.00	1350 905.02 905.03	1500 Q.1 905.04 905.05	1500 905.06 905.07
1	Power windows	16			X	X
2	Door lock control unit	16			X	
3	Heated rear window	16	X	X	X	X
4	Clock	16	X	X		X
	Horns-cigar lighter		X	X	X	X
5	Passenger compartment roof lamp- Intermittence of direction and hazard lights- Stop switch	8	X	X	X	X
	Roof lamp timer				X	X
	Trip Computer				X	
6	Windscreen wiper-Windscreen Wiper electronic intermittence generator. Windscreen wiper control-Windscreen washer pump control-Cluster	8	X	X	X	X
7	Heated rear window switch- Hazard lights switch -	8				
	Heater switch		X	X	X	X
	Power window switch Power window				X	X
	Clock		X	X		X

ELECTRICAL SYSTEM

Fuse	Protected Service	Ampere	Modal			
			1200 905.04	1360 905.02 305.03	1500 a.* 905.04 905.05	1500 905.06 905.07
8	Cut-off solenoid valve - Reverse switch Trip Computer - Check Control	8	X	X	X	X
9	Side lights left front and right rear-R. H.number plate light Clock Check Control Cigar lighter	8	X	X	X	X
10	Side lights right front and left rear-i. H.number plate light Check Control -Trip Computer-Headlights wiper Heater control lighting lamp - Cluster lighting lamp - Side light warning lamp	8	X	X	X	X
11	Right low beam	8	X	X	X	X
12	Left low beam - Rear fog light switch	8	X	X	X	X
13	Right full beam	8	X	X	X	X
14	Left full beam - Headlights warning lamp	8	X	X	X	X

Q* = Quadrifoglio

IGNITION SWITCH

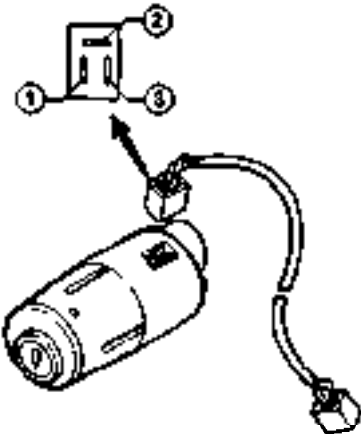
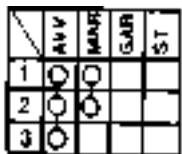

REMOVAL AND INSTALLATION

For removal and installation of the ignition switch - antitheft steering lock group, refer to: Groupe 23 - Steering Wheel and Column.

ELECTROMECHANIC AND ELECTRONIC DEVICES

RELAYS AND TIMER

LOCATION

The relays and the roof lamp timer are inserted into the special socket which is integral part of the fusebox

support board, located on left side of intermediate bulkhead. For location, refer to "Electric Component Location".

CHECK

The relays and the timer, must be of the type indicated in the specific table on page 40-8.

ELECTRONIC DEVICES AND INTERMITTENCES

LOCATION

The electronic device for headlights and flashing changeover, and the windscreen wiper electronic intermit-tence generator, are mounted on a support board, located in the inter-mediate bulkhead, in proximity to the fuse holder box.

The device which controls intermit-tences of both side lights and hazard lights, is located in the dashboard inside.

For identification of the various devices, see: "Electric Component Location".

CHECK

The electronic devices and intermit-tences must be of the type indicated in the specific table on page 40-9.

ELECTRICAL SYSTEM

“Relays and Timer” Table

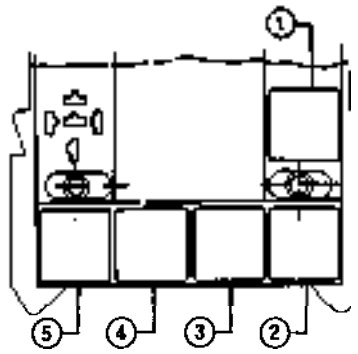

Component	External view	Symbols	Position
Passenger compartment roof lamp timer N10			1
Horns relay I3			2
Heated rear window relay I2			3
Headlight wiper relay I4			4
Front power windows relay I12			5

ELECTRICAL SYSTEM

Intermittences and electronic devices

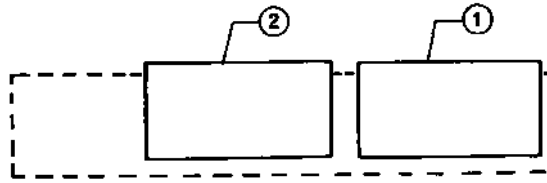

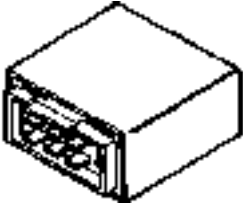
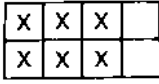
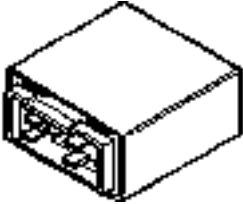
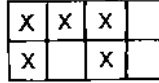
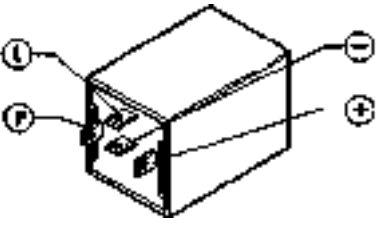
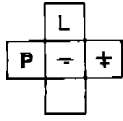
Component	External view	Symbols	Position
Windscreen wiper electronic intermittence N14			
Electronic device for headlights and flashing changeover N18			2
Hazard and direction lights intermittence N13			

LIGHTING SYSTEM

LAMPS

CAUTION:

Before starting operations on lighting system, make sure that the ignition switch is to the "ST" position and the battery ground cable is disconnected.

Lamp characteristic data, type and electric power are listed in the following table.

Lamps	Electric power (W)	Type
Front combination lamps :		
— low beam and full beam (H4 halogen lamp)	55/60	A
— front side light	4	B
— front direction indicator	21	B
Side direction indicator lamp	3	D
Rear combination lamps :		
— rear direction indicator	21	B
— rear side light	5	B
— number plate light	5	B
— reversing light	21	B
— rear fog light	21	B
— rear side and stop light	5/21	B
Warning lamp	1.2	D
Roof lamp	10	C

TYPES OF LAMPS

The lamps used for the car are of four types. For removal the following procedure is recommended.

1. Halogen lamp - type A

To remove it from lampholder, disconnect connector, then rotate retaining spring being careful not to touch it with naked hands.



2. Bayonet lamp - type B

To remove it from lampholder, press the bulb, rotate it counterclockwise, then withdraw it.



3. Cylindrical lamp - type C

To remove it from lampholder, release it from contacts pulling towards outside of lampholder.



4. Whole glass - type D

It is pressed into lamp holder and to remove it, it is necessary to withdraw lamp out of lampholder.



For installation of lamps, reverse order of removal.

COMBINATION SWITCH ASSEMBLY

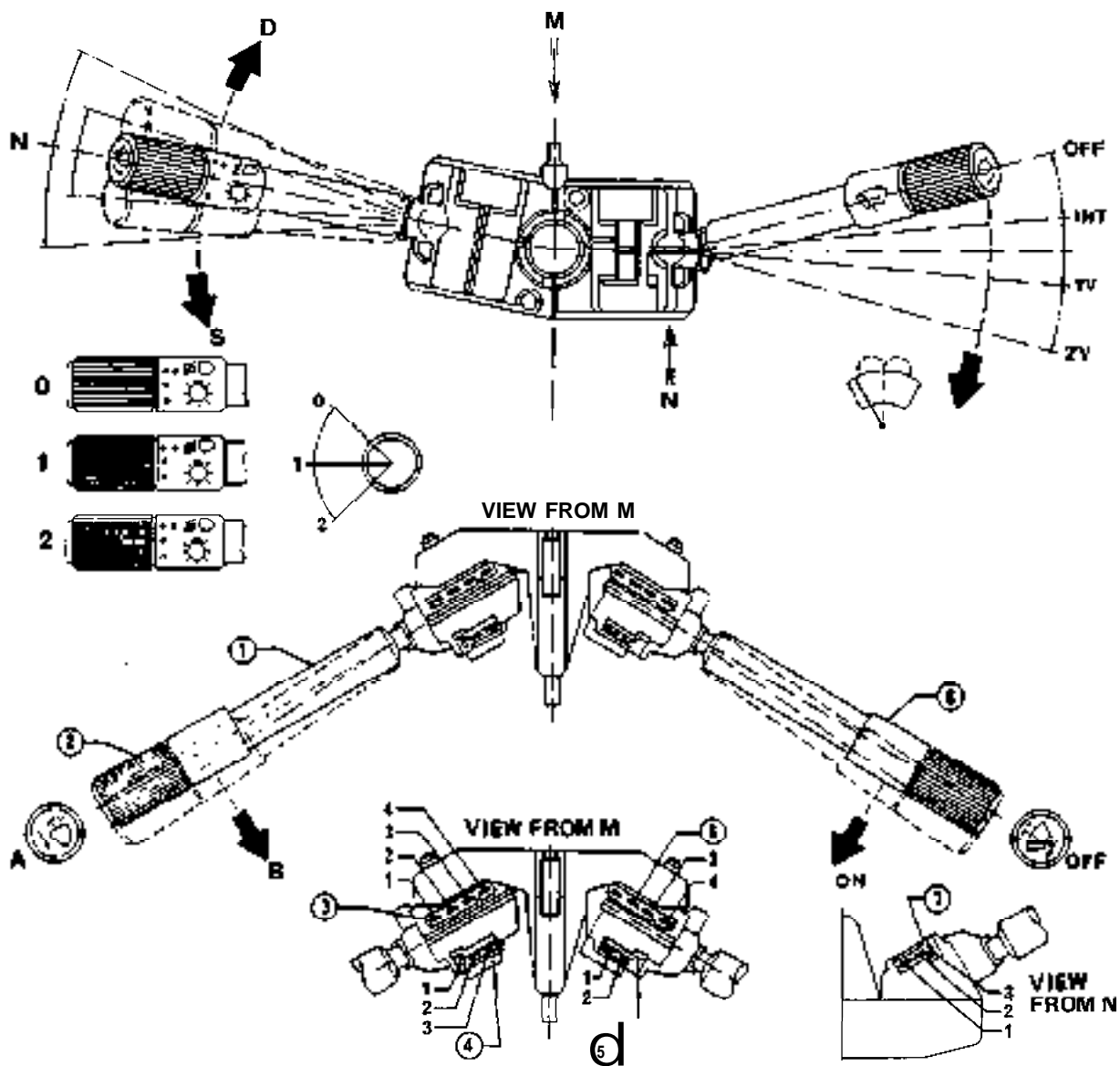

③

	0	1	2
	A B	A B	A B
1		○	
2		○	○
3			○
4			

④

	0	1	2
	OFF	D S	
1		○	
2			○
3			

⑤

	OFF	INT	TV	ZV
	D	1	2	3
1		○		
2		○	○	
3				○

⑧

	OFF	ON
1		
2		
3		
4		○

- 1 Left lever
- 2 Turning stalk
- 3 Connector
- 4 Connector
- 5 Connector
- 6 Connector
- 7 Connector
- 8 Right lever

ELECTRICAL SYSTEM

The following table shows the correspondances between positions of combination switch controls and the concerned services.

Control		Position	Service enabled	
Left lever	Stalk rotation	0	— zero position	
		1	— side lights	
		2	— low beams	
	Movement parallel to steering wheel axis	A	}	— zero position
		B		— full beam flashing (paired to rotation in the 0 and 1 positions) — Headlight change over (paired to rotation in position 2)
	Movement parallel to steering wheel plane	D	— Right - hand direction indicator	
	OFF	— Neutral position		
	S	— Left - hand direction indicator		

Control		Position	Service enabled
Right lever	Movement parallel to steering wheel plane	0	— zero position
		1	— windscreen wiper intermittence
		2	— windscreen wiper 1st speed
		3	— windscreen wiper 2nd speed
	Movement parallel to steering wheel axis	ON	— windscreen washer and/or headlight wash-wiper with wiping stroke driven from control unit
		OFF	— zero position

REMOVAL AND INSTALLATION

1. Removing steering wheel.
2. Unscrew the five securing screws and remove upper and lower shell covers of steering column (see Group 23 - Steering Wheel and Column).
3. Disconnect connectors ② of the combination switch unit.
4. Remove combination switch unit by unscrewing the two screws ① securing it to steering column.
If necessary, disassemble combination switch unit separating the two levers.
5. For installation reverse order of removal.

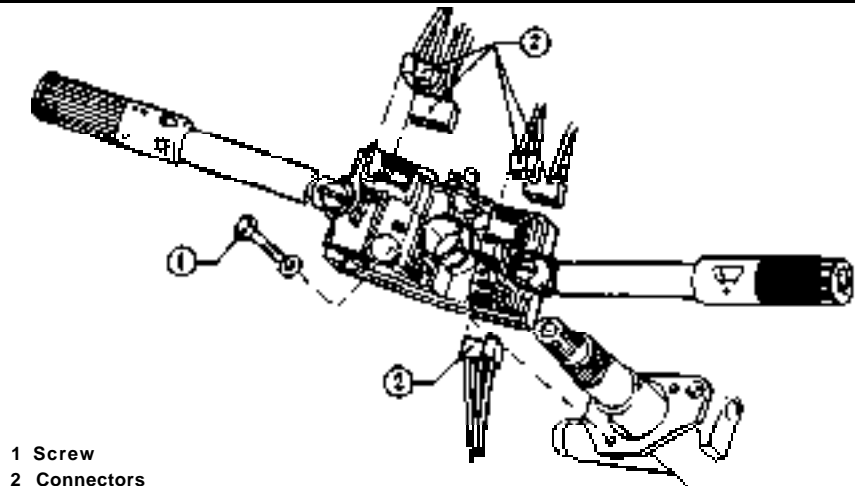

1 Screw
2 Connectors

CHECKS AND INSPECTIONS

Check harness integrity and, by

means of a tester, check electric continuity.

OUTSIDE LIGHTING

OUTSIDE LIGHTING - FRONT SIDE

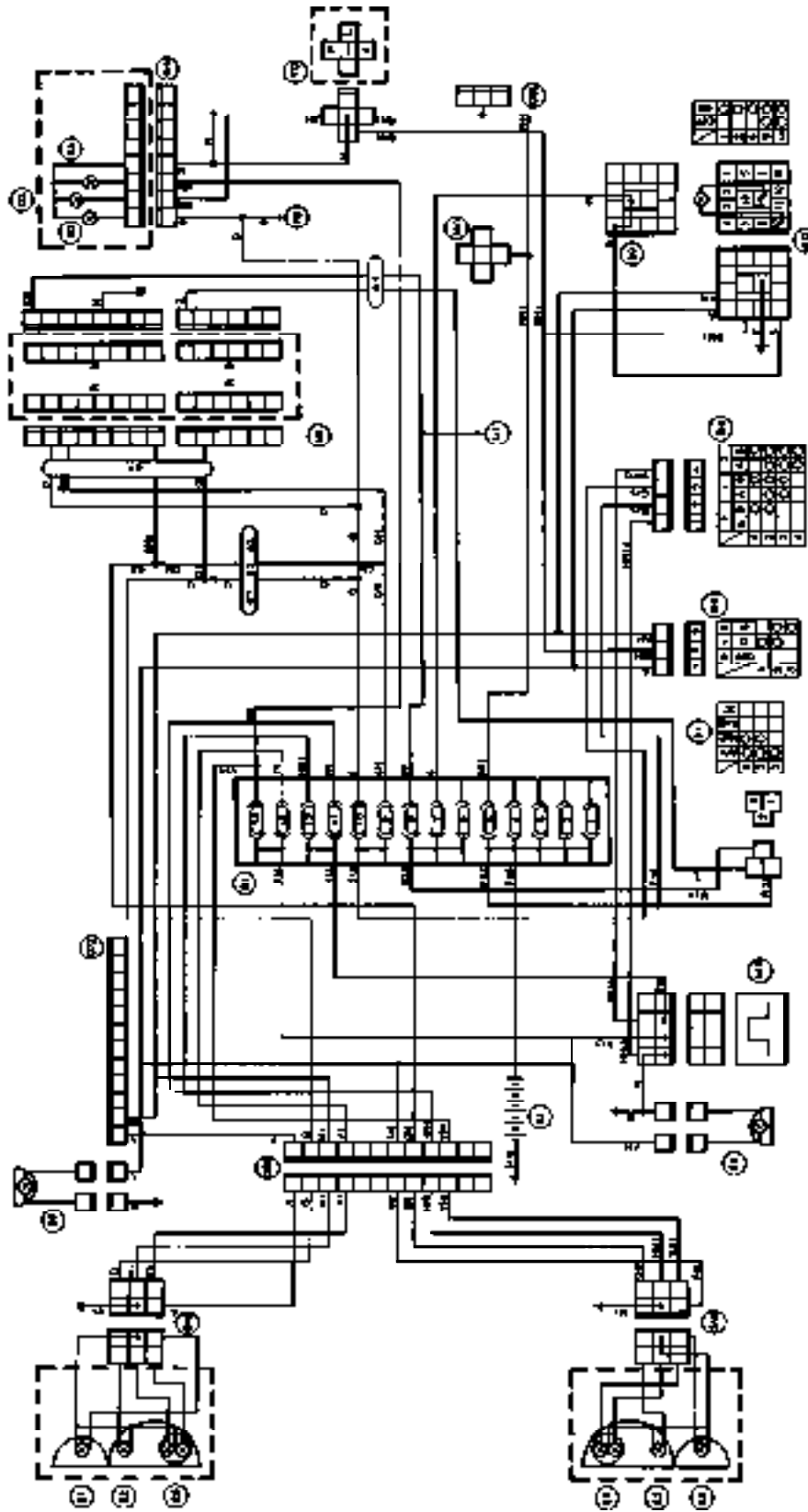

- A1 Battery
- B1 Ignition switch
- B4 Control switch headlights, flashing, low beam and full beam
- B6 Direction lights indicator switch
- B8 Heated rear window control switch
- B12 Hazard light control switch
- C2 Direction light warning lamp
- D6 Side light warning lamp
- D4 Full beam warning lamp
- E1 Front direction indicator light lamp
- E2 Front side light lamp
- E8 Low beam and full beam lamp
- E9 Side direction light lamp
- F8 Air ventilation controls, lighting lamp
- G1 Fusebox
- G6 Cluster B connector
- G48 Headlight connector
- G13 Rear service connector
- G85 Front service connector
- G86 Passenger compartment pool lamp connector
- N1 Trip Computer
- N8 Check Control
- N10 Passenger compartment roof lamp
- N13 Hazard and direction lights inoperative
- N18 Electronic device for headlights and flashing changerover
- G1 L.H.D. 1200 model
- G2 R.H.D. - L.H.D. 1380 model
- G3 R.H.D. - L.H.D. 1500 model
- G4 R.H.D. - L.H.D. 1500 Quadrotor model

ELECTRICAL SYSTEM

OUTSIDE LIGHTING - REAR SIDE

(for the 1200 - 1350 - 1500 models)

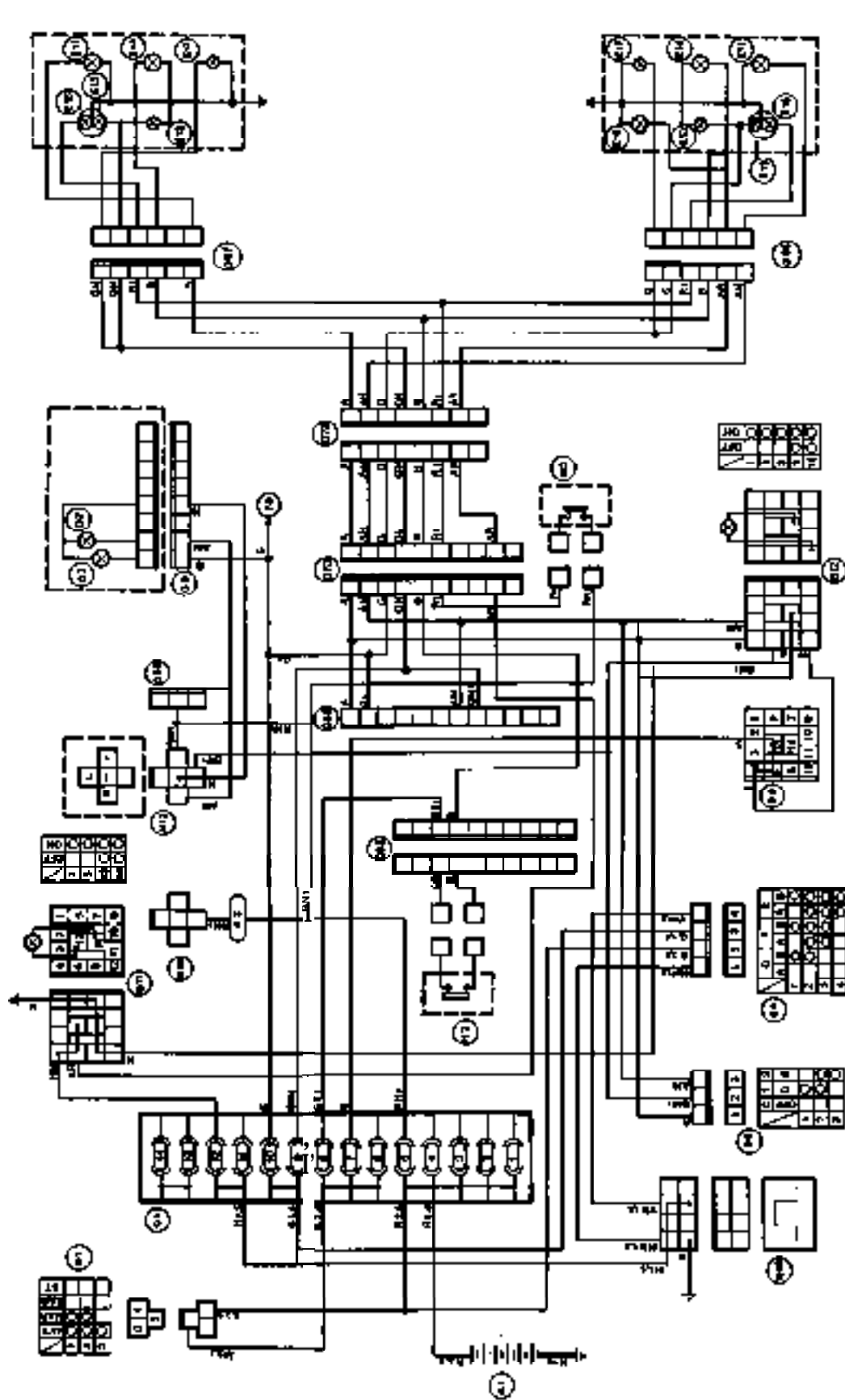

- A1 Battery
- B1 Ignition switch
- B4 Control switch for headlights, flashing, low beam and full beam
- B5 Direction lights indicator switch
- B8 Heated rear window control switch
- B11 Rear fog light control switch
- B12 Hazard lights control switch
- D2 Direction light warning lamp
- D3 Side light warning lamp
- E11 Rear direction light lamp

- E13 Tail light lamp
- E14 Reverse light lamp
- E15 Stop light lamp
- E16 Rear fog light lamp
- E17 Number plate light lamp
- F8 Air ventilation controls lighting lamp
- G1 Fusebox
- G4 Cluster & connector
- G13 Rear service connector

- G85 Front service connector
- G86 Passenger compartment roof lamp connector
- G88 Tail lights connector
- H2 Reverse light switch
- H3 Stop light switch
- N10 Passenger compartment roof lamp timer
- N13 Hazard and direction lights interrelays
- N18 Electronic device for headlights and flashing chamepower
- Q9 R.H.D. - L.H.D. 1500 model

ELECTRICAL SYSTEM

HEADLIGHT SWITCH

Low beam/full beam light change-over is executed via left lever of combination switch (see: Combination Switch Assembly).

DIRECTION LIGHT SWITCH

Operation of direction indicators is executed via left lever of combination switch (see: Combination Switch Assembly).

HAZARD LIGHTS SWITCH

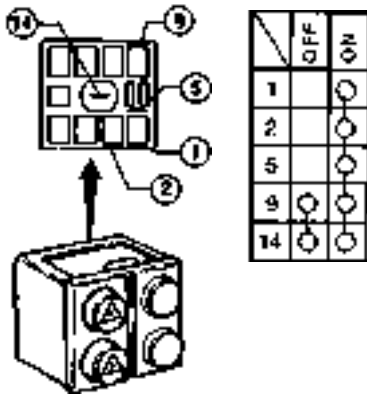

Location

The switch is mounted on upper ornament of central console (see: Groupe 66 - Consoles).

Check

Verify switch functioning by checking whether continuity between terminals occurs in accordance with the indications provided in table.

REVERSE LIGHT SWITCH

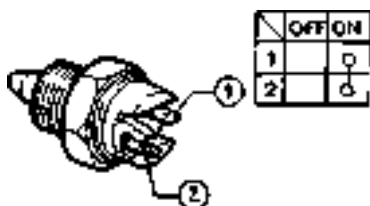

Location

The switch is mounted on gearbox (see: Group 13).

Check

Connect a tester to terminals of reverse switch and verify the following resistance values.

When in the OFF position = $\infty \Omega$
When in the ON position = 0Ω

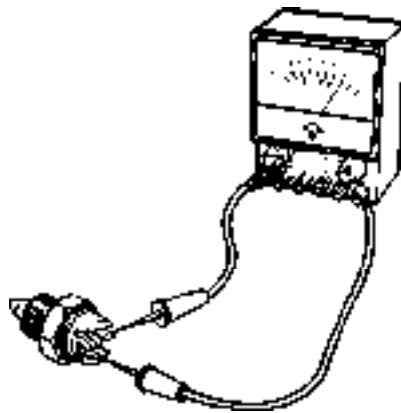

STOP LIGHT SWITCH



Location

The switch is mounted on the relevant bracket of pedal assembly.

Check

Connect a tester to terminals of stop light switch and verify the following resistance values.

When in the OFF position = $\infty \Omega$
When in the ON position = 0Ω

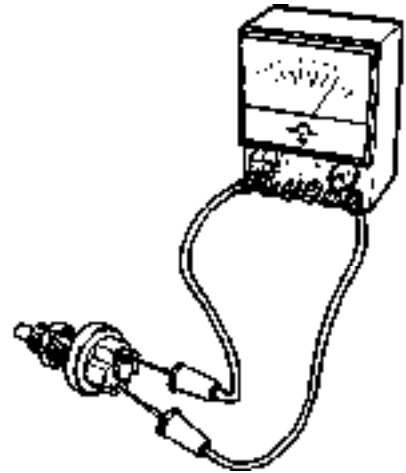

REAR FOG LIGHT SWITCH

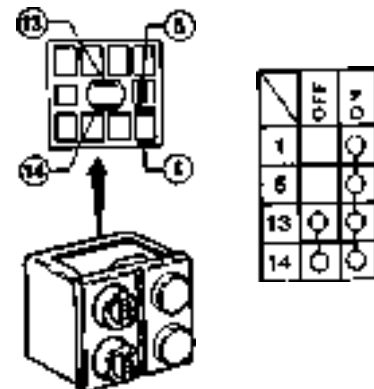

Location

The switch is mounted on upper ornament of central console (see: Group 66 - Consoles).

Check.

Verify switch functioning by checking whether continuity between terminal occurs in accordance with the indications provided in table.

ELECTRICAL SYSTEM

FRONT COMBINATION LAMPS

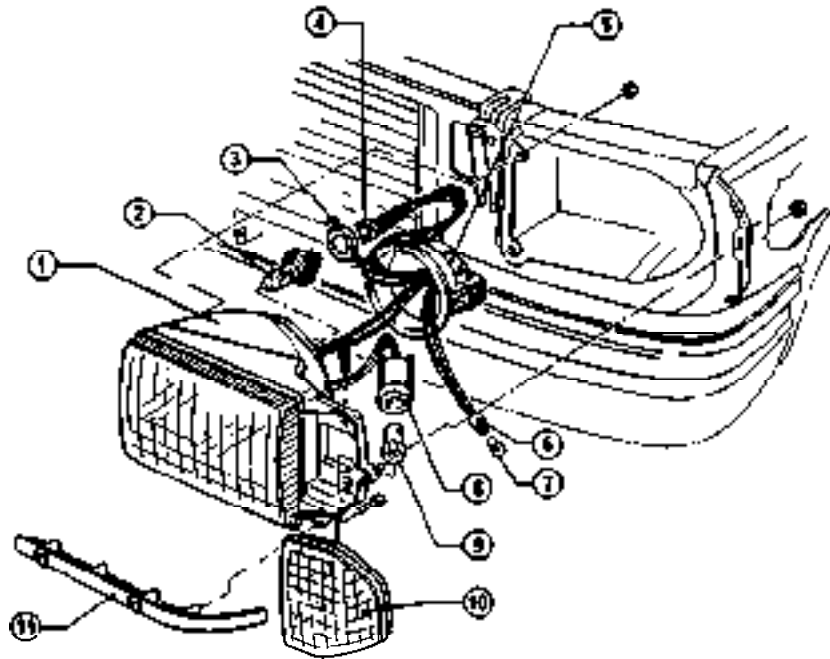

1 Front combination lamp
2 Halogen lamp
3 Securing spring
4 Supply connector
5 Cover
6 Lamp holder

7 Lamp
8 Lampholder
9 Lamp
10 Plastic cover
11 Headlight wiper clamp

REMOVAL AND INSTALLATION

With reference to the exploded view proceed as follows.

1. Operating from engine compartment inside, disconnect harness from cover (5).
2. Remove grille (see: Group 75 - Grille).
3. Unscrew the two nuts securing combination lamps to body.

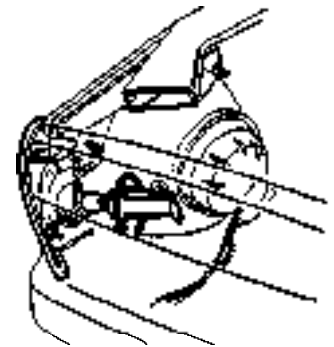
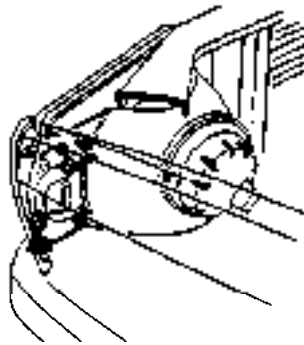

- (2) Unscrew the two screws securing transparent cover (10) to combination lamps (1), then remove it.

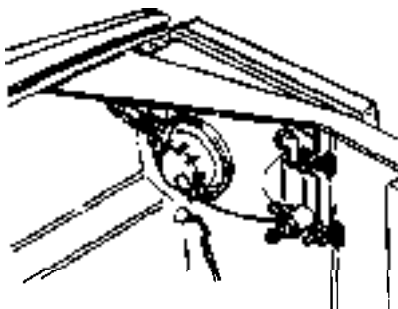

4. Operating from fender inside, unscrew nut securing combination lamps to fender itself and remove it.

5. For combination lamp installation, reverse order of removal.
6. Adjust luminous beam by following the procedures described in "Setting of headlights low beam".

Replacement of transparent cover (10) can be carried out on mounted combination lamps (1), by operating from engine compartment inside.
(1) Rotate lampholder (8) counter-clockwise and withdraw it from transparent cover (10).

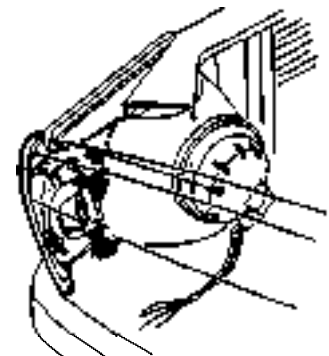

(3) For installation of transparent cover, reverse order of removal.

LAMP REPLACEMENT

Headlights and front side lights

1. Operating from engine compartment inside, rotate cover ① clockwise, then remove it.

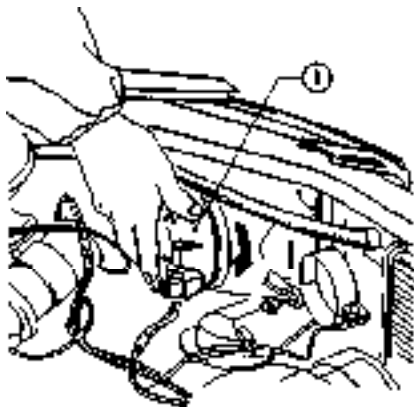

1 Cover

2. Disconnect supply connector ①.

3. Rotate securing spring ③ counterclockwise, and remove it.

4. Withdraw halogen lamp ② and replace it. On reassembly, replace the lamp, make sure the cover is properly positioned by correct alignment of the notches.

5. To remove headlight lamp ④, withdraw lampholder ⑤, press bulb and rotate it counterclockwise.

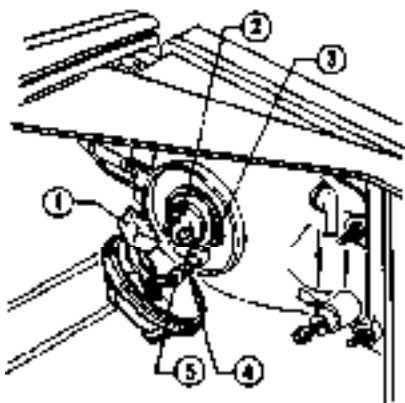

1 Supply connector
2 Halogen lamp
3 Securing spring
4 Lamp
5 Lampholder

6. For installation, reverse order of removal.

CAUTION:

Do not touch with the hands glass of headlight halogen lamp 2. If this occurs, wash the glass.

Front direction indicators

1. Operating from engine compartment inside, rotate lampholder ② counterclockwise, then remove it.

2. Press lamp bulb ① and rotate it in order to withdraw lamp.

3. Replace the lamp and install lampholder ②.

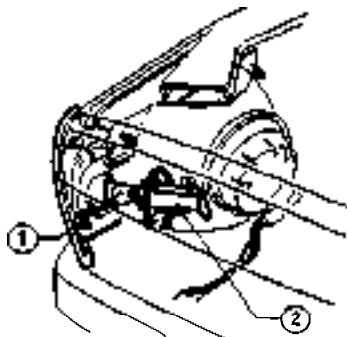

1 Lamp 2 Lampholder

Side direction indicators

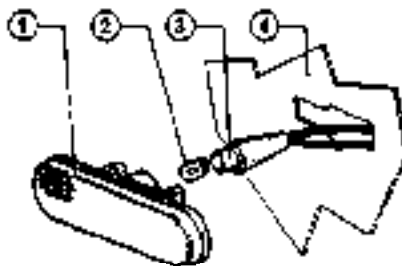

1 Side direction indicator
2 Lamp
3 Lampholder
4 Fender

1. Operating from fender inside, compress the two springs securing transparent cover of side direction indicator ① to fender ④, then remove it.

2. Withdraw lampholder ③ from direction indicator ①.

3. Replace lamp ② by pulling the relevant bulb.

4. Install direction indicator by reversing order of removal.

SETTING OF HEADLIGHTS LOW BEAM

Carry out the following procedure to adjust headlight low beam.

1. Check that tires are inflated at the right pressure and that car is free from any load excepted those of service supplies and of one passenger equivalent.

2. Position the car and the possible test equipment on an horizontal plane. If no test equipment is available, place the car in front of a clear screen.

3. Move car back of about 10 m (32,8 ft) and switch on low beams. The luminous beam must be in compliance with geometric dimensions provided in figure.

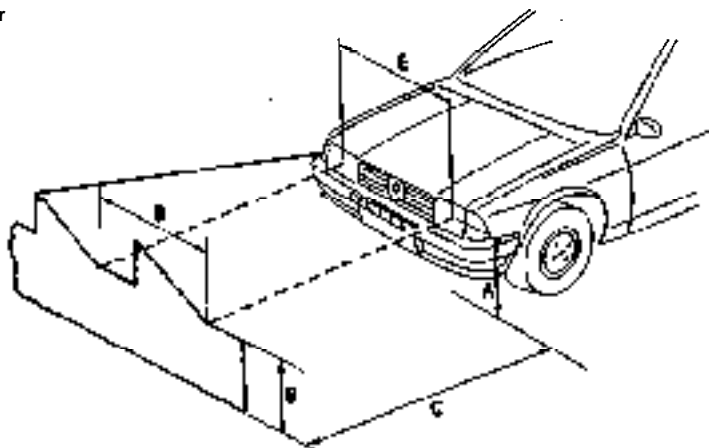

ELECTRICAL SYSTEM

- A = distance of headlight centre from ground
B = height of luminous beam
C = 10 m (32,8 ft)

Orientation is correct when the following condition occurs:

$$B = 470 \text{ mm (18,5 in)}$$

Distance D between luminous beams

centre must be equal to distance E between headlight center.

The dimensions indicated in the diagram comply with provisions in force in Italy. For other countries, comply with national provisions.

For correction of possible orientation errors, from engine compartment inside, operate on adjusting screws of headlights set in evidence in the following figure.

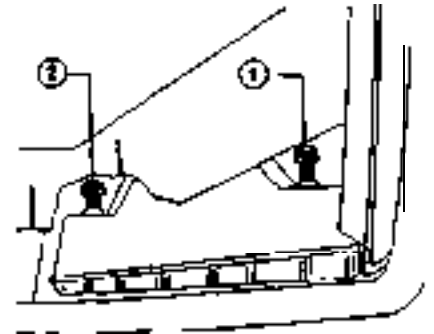

- 1 Horizontal direction adjustment screw
2 Vertical direction adjustment screw

REAR COMBINATION LAMPS

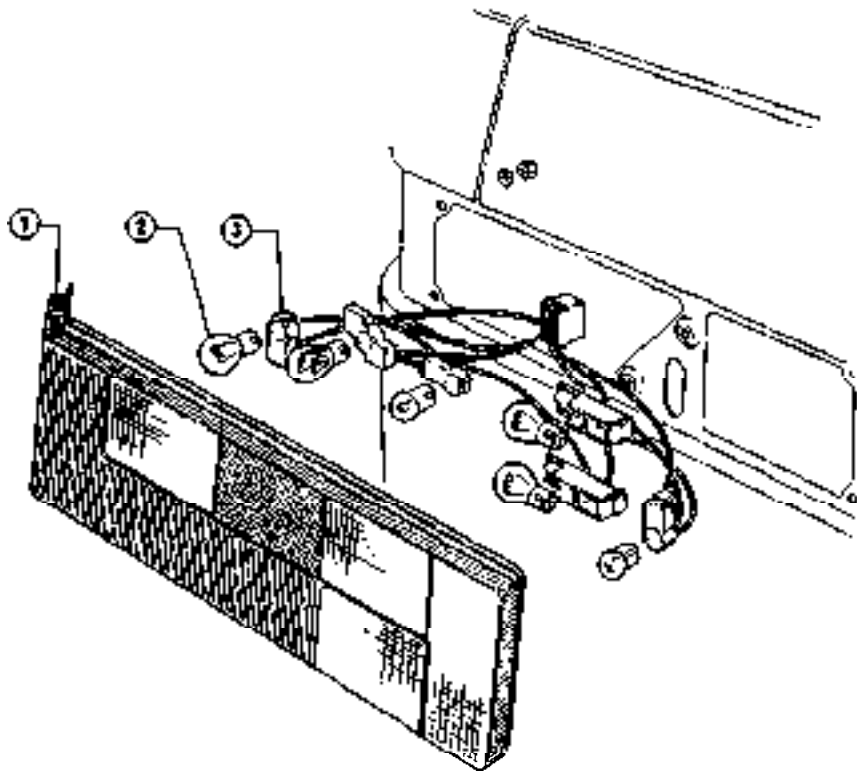

- 1 Combination lamps
2 Lamp
3 Lampholder

REMOVAL AND INSTALLATION

With reference to the exploded view, operate as follows.

1. Open back door and lift rear trim.
2. Disconnect connector.
3. Unsaew the six nuts securing combination lamps to body, then remove combination lamps.

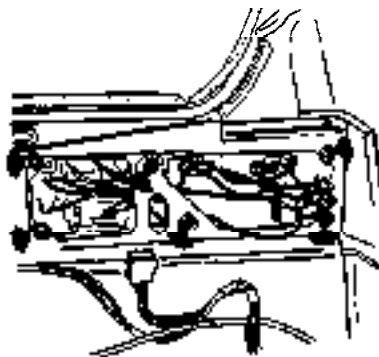

4. For installation of combination lamps, reverse order of removal.

LAMP REPLACEMENT

The following procedure is applicable to all lamps and lampholders.

ELECTRICAL SYSTEM

1. Open back door and lift rear trim.
2. Press on lampholder side (2), pull; then remove it.

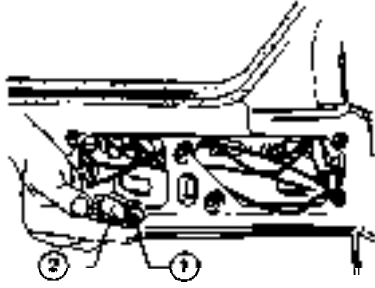

- 1 Lamp
- 2 Lampholder

3. Press bulb of lamp and rotate it in order to remove.
4. Replace lamp and refit lampholder.
5. For identification of lamp location, refer to diagram of the following figure.

Diagram refers to the left rear combination lamp.

The right-hand one is specular with respect to the left-hand.

The rear fog light is present in the left rear combination lamp only.

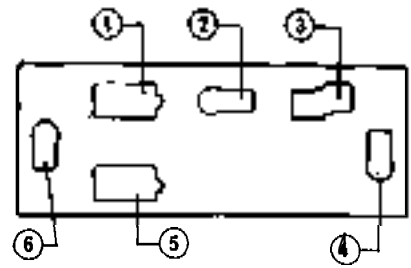

- 1 Rear fog light
- 2 Side light
- 3 Stop and side lights
- 4 Direction indicator
- 5 Reverse light
- 6 Number plate light

INSIDE LIGHTING

1200 and 1350 model

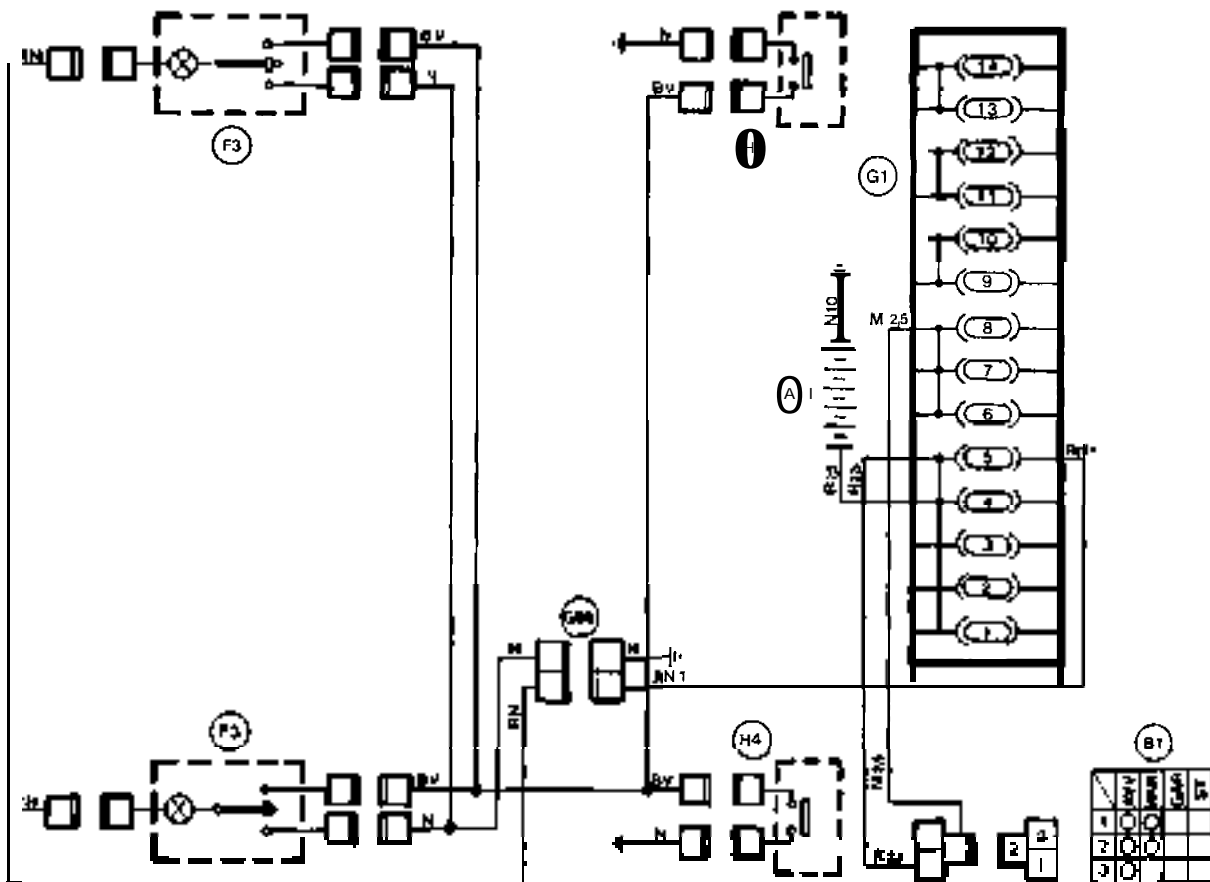

ELECTRICAL SYSTEM

1500 and 1600 Quadrifoglio model

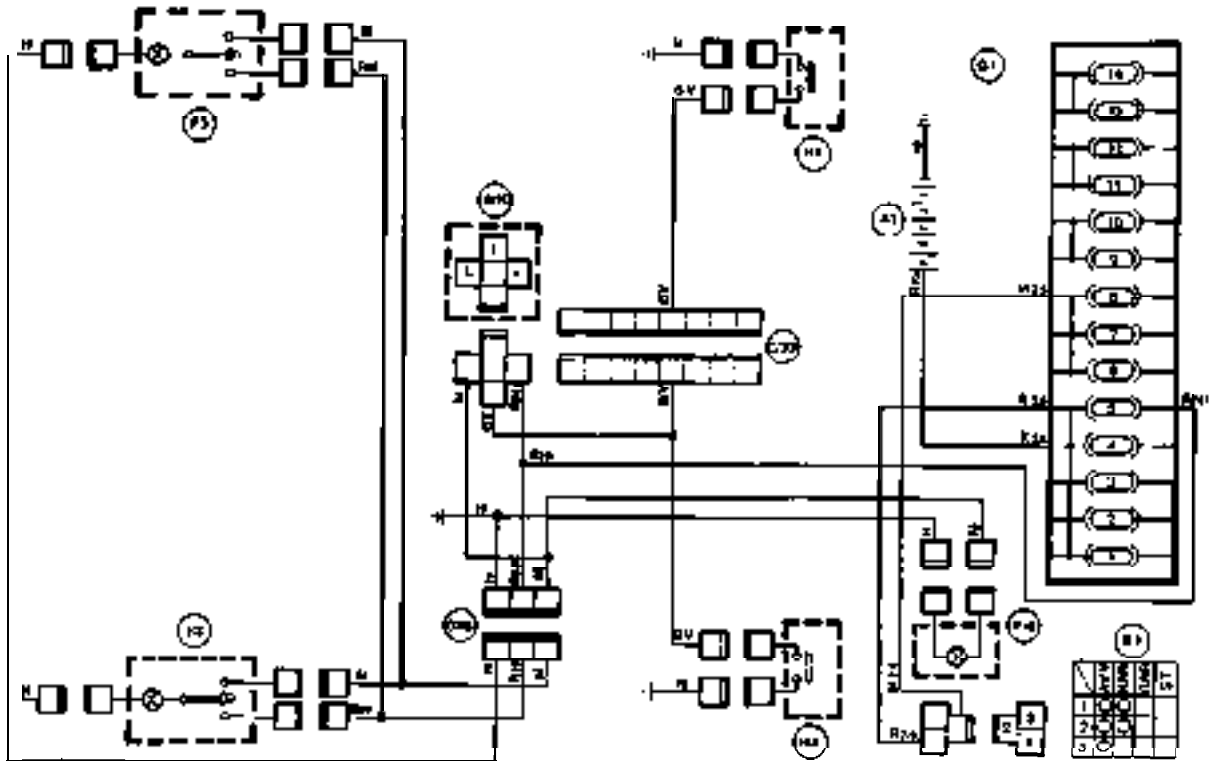

A1 Battery
B1 Ignition switch
F3 Passenger compartment roof lamp
F16 Ignition switch lighting lamp
G1 Fusebox

G30 Power window and door lock connector
G86 Passenger compartment roof lamp connector
H4 Roof lamp switch on passenger compartment pillar
N10 Passenger compartment roof lamp timer

ROOF LAMP

Lamp replacement

1. By means of proper tool, remove transparent cover, pressure inserted into lampholder.
2. Withdraw and replace the lamp..
3. For lamp installation, reverse order of removal.

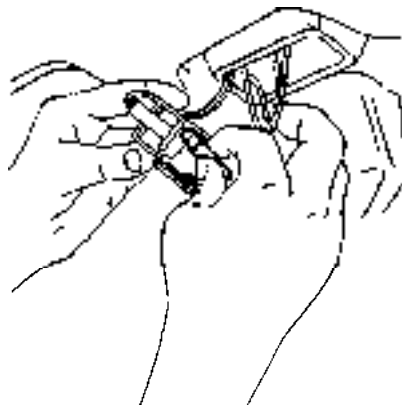
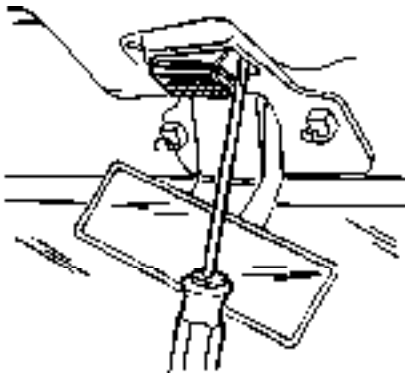

CAUTION:

Before starting operations, make sure that the ignition key is to the "ST" position and ground cable is disconnected.

REMOVAL AND INSTALLATION

1. Unscrew the four screws (5)

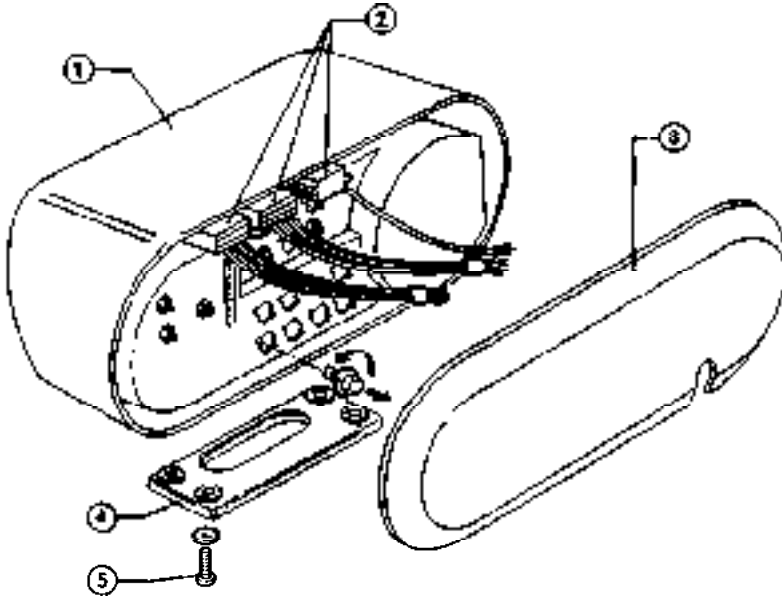

- 1 Cluster
- 2 Connector
- 3 Cover
- 4 Bracket
- 5 Screw

securing cluster (1) to support bracket (4).

2. Remove the pressure inserted cover (3), disconnect harness (2), then remove cluster.

3. For installation, reverse order of removal.

LIGHTING AND WARNING LAMPSREPLACEMENT

1. Remove cluster (see: Removal and Installation).
2. Rotate lampholder and withdraw it; then remove lamp from lampholder itself.
3. Replace lamp with an identical one then carry out installation by reversing order of removal.

ELECTRICAL SYSTEM

ENGINE COOLANT LEVEL SENSOR

Check

Location

The sensor is inset-ted into header tank of cooling system.

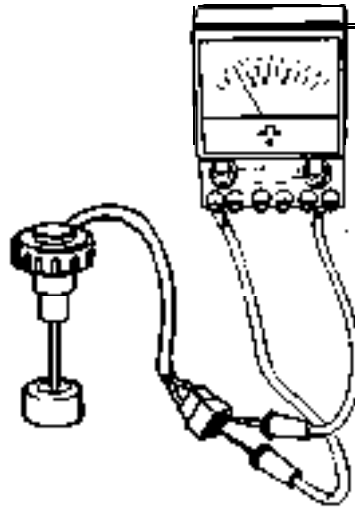

1. Connect the two ends of tester to sensor connector just as per figure.
2. Check sensor proper functioning by verifying the following:

Float lifted: $\infty \Omega$

Float lowered: 0Ω

ELECTRICAL SYSTEM

FUEL LEVEL TRANSMITTER

Removal and installation

For removal and installation see:
Groupe 04 - Supply System.

CLUTCH AND BRAKE OIL MINIMUM LEVEL TRANSMITTER

Check

1. Set the ignition key to the MAR position.

2. Connect a lamp indicator to pins of float plug, as per figure.
3. Check device proper functioning by verifying the following.

Float lifted:
lamp indicator off

Float lowered:
lamp indicator on

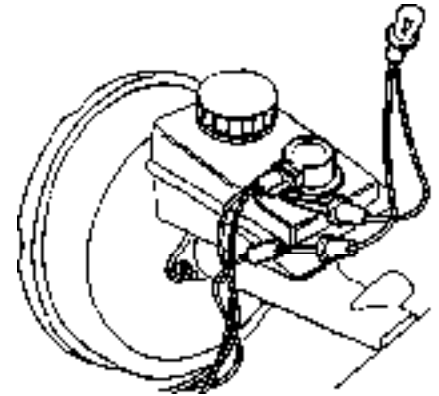

WINDSCREEN WASH/WIPER AND HEADLIGHT WASH /WIPER

WINDSCREEN WASH/WIPER

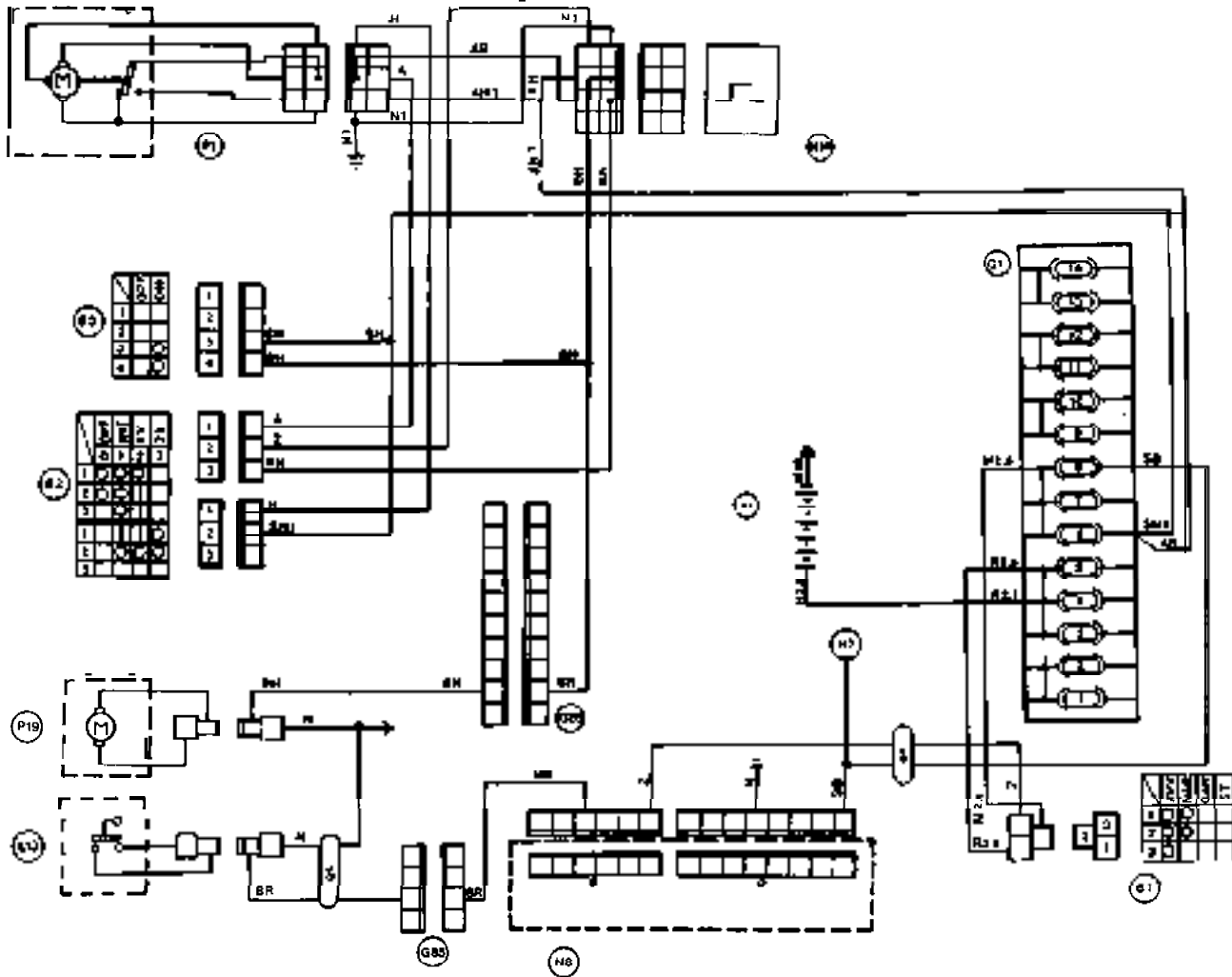

- A1 Battery
- B1 Ignition switch
- B2 Windscreen wiper control switch
- B3 Windscreen washer and/or headlight wash/wiper pump control switch
- G1 Fusebox

- G85 Front service connector
- L13 Windscreen washer liquid level sensor
- N7 Trip Computer
- N8 Check Control
- N14 Windscreen wiper electronic intermittence
- P1 Windscreen wiper motor
- P19 Windscreen washer electric pump
- CL4 R.H.D. L.H.D. Quadrifoglio model

WINDSCREEN WIPER

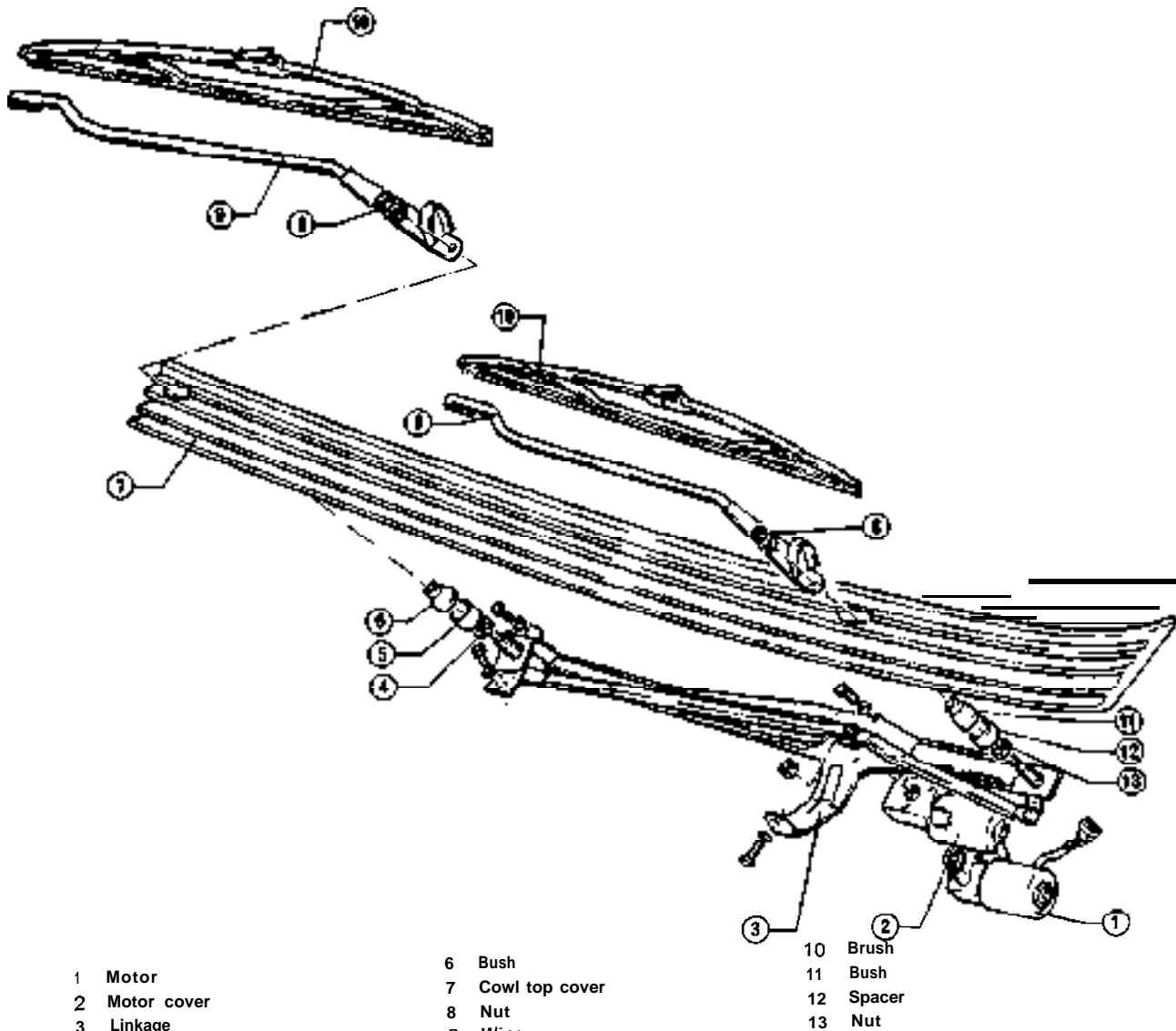

- 1 Motor
- 2 Motor cover
- 3 Linkage
- 4 Nut
- 5 Spacer

- 6 Bush
- 7 Cowl top cover
- 8 Nut
- 9 Wiper arm

- 10 Brush
- 11 Bush
- 12 Spacer
- 13 Nut

REMOVAL AND INSTALLATION

1. Disconnect motor (1) harness.
2. Withdraw brushes (10) from wiper arms (9).
3. Lift covers of nut (8) securing wiper arms (9), unscrew nuts, then remove wiper arms.

4. Remove cowl top cover (7) (see: Group 75 - Cowl top cover).
5. Withdraw bush (11), unscrew nut (13), then remove it together with spacer (12).
6. Unscrew the three screws securing linkage (3) to body, then remove it.

7. Unscrew the three screws securing motor (1) to linkage (3) and nut securing motor shaft to linkage.

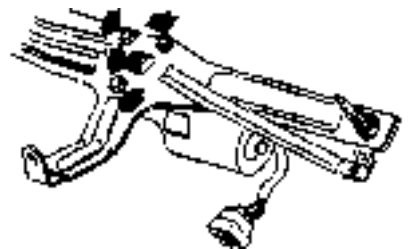

8. Remove motor (1) and withdraw cover (2).
9. For windscreen wiper installation, reverse order of removal.

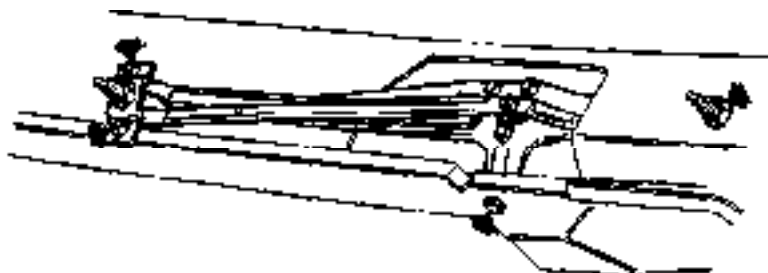

ELECTRICAL SYSTEM

TROUBLE DIAGNOSIS AND CORRECTIONS

Condition	Probable cause	Corrective action
Windshield wiper does not operate	<ul style="list-style-type: none"> • Burnt fuse • Loose connection or open circuit • Improper switch contact • Foreign material interrupts link mechanism • Disconnected rod. • Seized or rusted arm shaft 	<p>Replace fuse</p> <p>Restore connection</p> <p>Verify combination switch; (right light); replace, if necessary</p> <p>Take off foreign material</p> <p>Connect rod.</p> <p>Replace shaft</p>
Windshield wiper operating speed is too slow	<ul style="list-style-type: none"> • Short circuit of motor armature • Worn brushes or seized shaft • Low source voltage • Humming of motor 	<p>Replace motor</p> <p>Replace brushes</p> <p>Verify voltage supply</p> <p>Replace motor</p>
Windshield wiper does not stop correctly	<ul style="list-style-type: none"> • Faulty auto-stop device • Faulty wiper motor 	<p>Replace auto-stop device</p> <p>Replace motor</p>
Washer fluid does not eject (washer motor operates)	Clogged washer nozzle or hose	Free nozzle or hose
Wiper does not operate intermittently but operates at low and high speeds	<ul style="list-style-type: none"> • Faulty wiper switch • Faulty wiring • Faulty intermittence 	<p>Replace combination switch (right lever)</p> <p>Verify wiring</p> <p>Replace intermittence</p>
Intermittent speed is too short for proper wiping	<ul style="list-style-type: none"> • Faulty auto-stop device • Faulty intermittence 	<p>Replace auto-stop device</p> <p>Replace intermittence</p>
Intermittent speed is too long, for proper wiping	<ul style="list-style-type: none"> • Line voltage below 10 volts • Faulty intermittence 	<p>Restore voltage</p> <p>Replace intermittence</p>

ELECTRICAL SYSTEM

Condition	Probable cause	Corrective action
Intermittent speed is erratic	<ul style="list-style-type: none">• Faulty wiper switch• Faulty wiring• Faulty wiper motor• Faulty intermittence	Replace switch Verify wiring Replace motor Replace intermittence

HEADLIGHT WASH/WIPER

1500 Quadrifoglio model

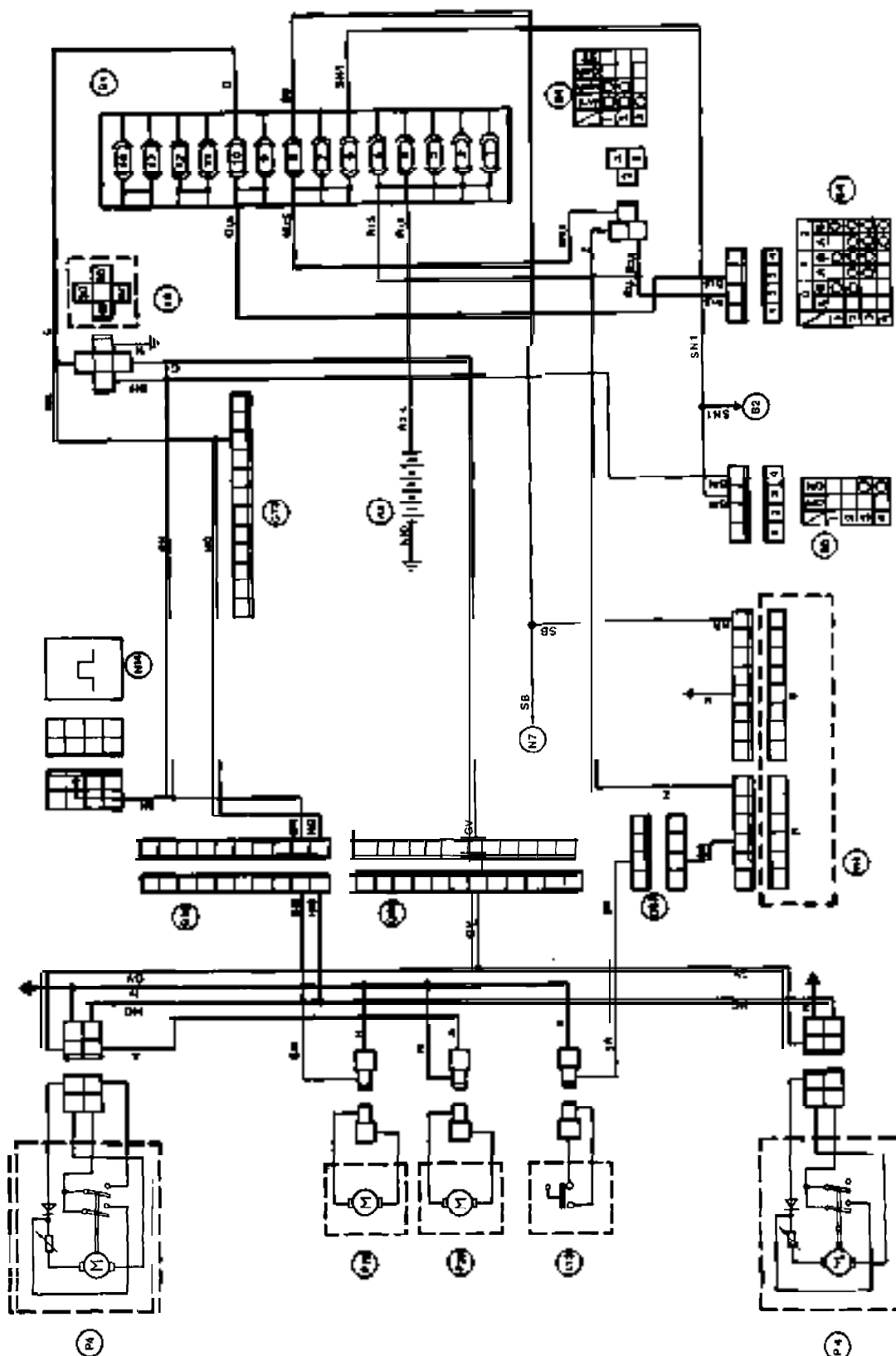

- A1 Battery
- B1 Ignition switch
- B2 Windscreen wiper control switch
- B3 Windscreen wiper and/or headlight wash/wiper pump control switch
- B4 Control switch for headlight, flashing, low beam and full beam
- G1 Fusebox

- G73 Rear service connector
- G88 Front service connector
- M4 Headlight wiper relay
- L13 Windscreen washer liquid level sensor
- V7 Trip Computer
- N8 Check Control

- M14 Windscreen wiper electronic intermittent
- P4 Headlight wiper motor
- P19 Windscreen washer electric pump
- P20 Headlight washer electric pump

HEADLIGHT WIPER

1500 **Quadrifoglio** modal

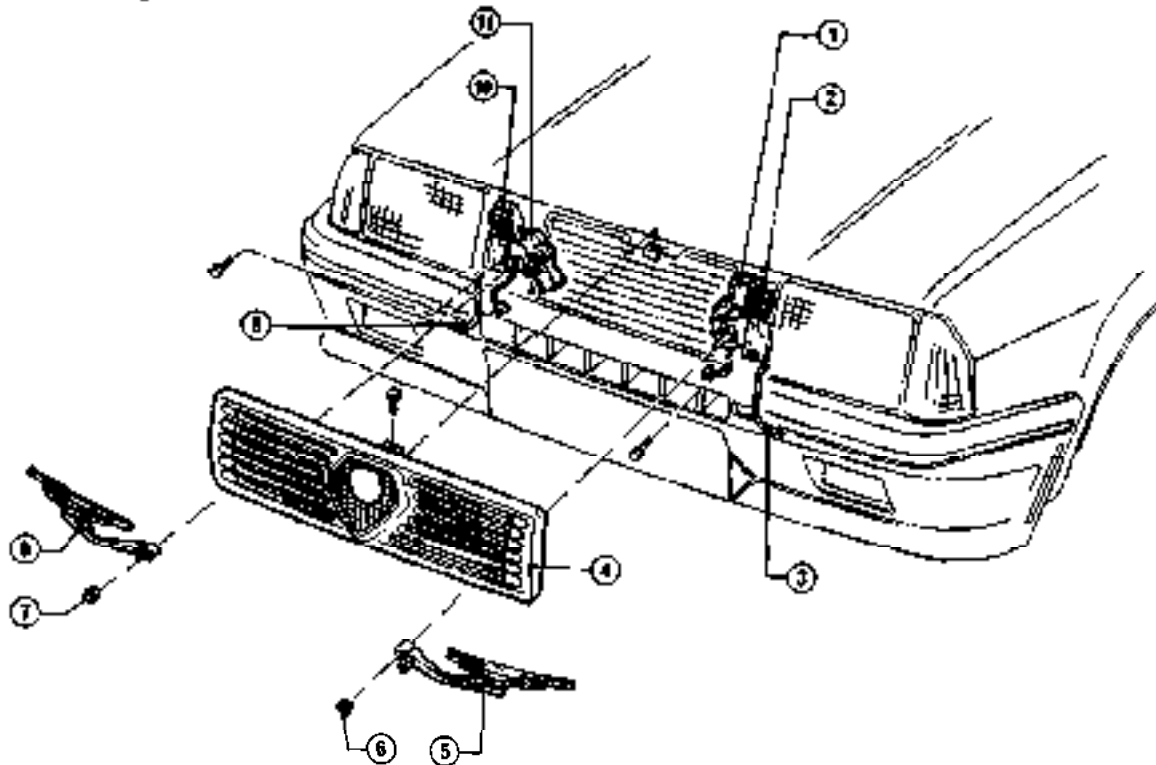

- | | |
|-------------------------|-------------------------|
| 1 Motor | 7 Nut |
| 2 Bracket | 8 Wiper arm |
| 3 Headlight washer hose | 9 Headlight washer hose |
| 4 Grille | 10 Bracket |
| 5 Wiper arm | 11 Motor |
| 6 Nut | |

REMOVAL AND INSTALLATION

With reference to the exploded view above proceed as follows.

1. Disconnect harness of motor ①.
2. Lift cover of nuts ⑥ and ⑦ securing wiper arms ⑤ and ⑧, unscrew nut and disconnect headlight washer hoses ③ and ⑨.
3. By means of tool A.3.0602, remove wiper arms ⑤ and ⑧.

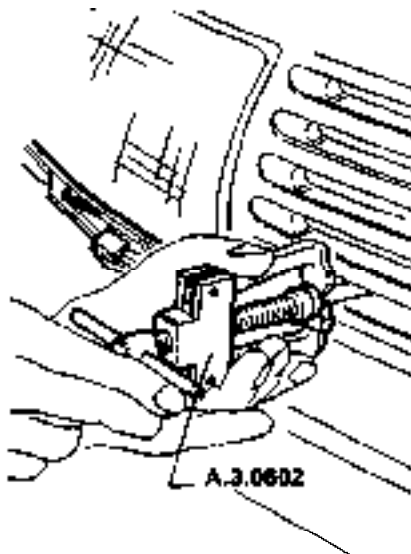

4. Remove grille (see: Group 75 - Grille).

5. Unscrew the six screws securing motors ① and ⑪ to bracket ② and ⑩, then remove motors.

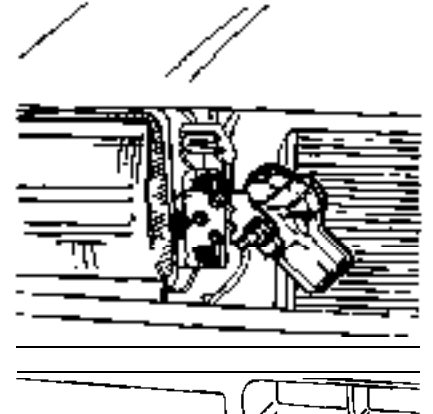

6. For windscreen wiper installation, reverse order of removal.

ELECTRICAL SYSTEM

SPECIAL SERVICE TOOLS

Tool number	Tool name	Refer to page
A.3.0602	Wiper arm puller 	40-33

HORNS

Location

The horns are mounted inside engine compartment on support brackets located under front combination lamps.

Removal and installation

1. Operating from engine compartment inside, disconnect horn harness ①.
2. Unscrew the nut ② securing horn to support bracket ③; then remove the bracket.
3. For installation, reverse order of removal.

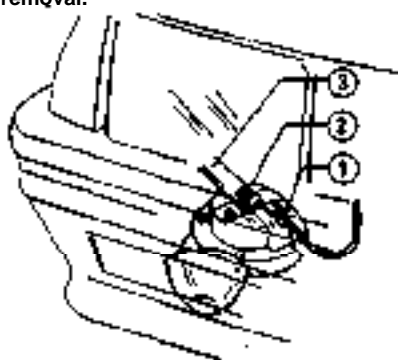

1 Harness 3 Bracket
2 Nut

HORN CONTROL PUSHBUTTON

Location

The pushbutton is located at centre of steering wheel (see: Group 23 - Steering Wheel and Column).

Check

1. Connect ends of tester to pushbutton terminal, operating as per figure.
2. Check pushbutton proper functioning by verifying the following:

Pushbutton lifted: $\infty \Omega$
Pushbutton depressed: 0Ω

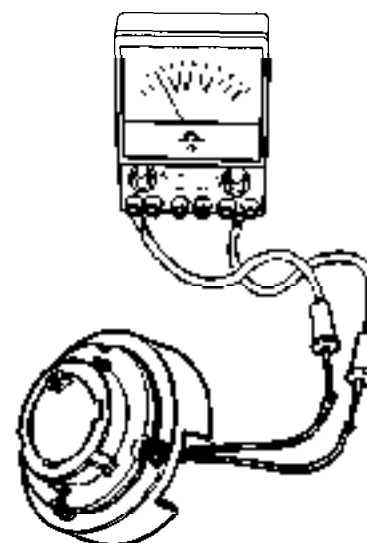

TROUBLE DIAGNOSIS AND CORRECTIONS

Condition	Probable cause	Corrective action
Only one side operates	<ul style="list-style-type: none"> • Faulty hose • Loose connector contact 	Replace horn Restore connection
Poor tone quality on one side	Tone adjustment not good	Adjust tone by operating on the relevant adjusting screw ①
Both horn volume reduced	<ul style="list-style-type: none"> • Low battery charge • Faulty charging system • Faulty connector contact 	Charge battery or replace Verify charging system Restore connection
Both horns do not operate	<ul style="list-style-type: none"> • Wiring cut-out • Faulty control push button • Discharged battery • Both horns faulty 	Restore connection Replace push button Charge battery Replace both horns

ELECTRICAL SYSTEM

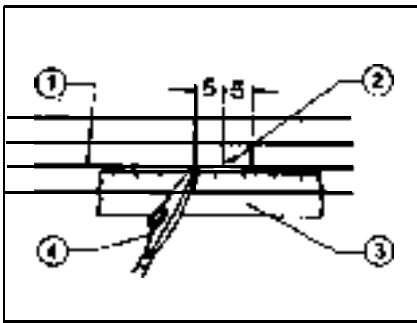

4. Dry end of ruling pen to remove silver compounds.
5. Once the repair has been carried out, wait for about 10 minutes, then verify electric continuity of the wire in object.

6. By means of a hot air jet, heat the repaired area for about 20 minutes, keeping the orifice of heat-gun at about 3 cm (1,2 in) from surface. If a heat-gun is not available, let dry for 24 hours.

During test, do not touch with the fingers the repaired resistor,

- | | |
|----------------|--------------|
| 1 Filament | 3 Rule |
| 2 Interruption | 4 Ruling pen |

POWER WINDOW

1350 model (Italy, only) and 1500 model

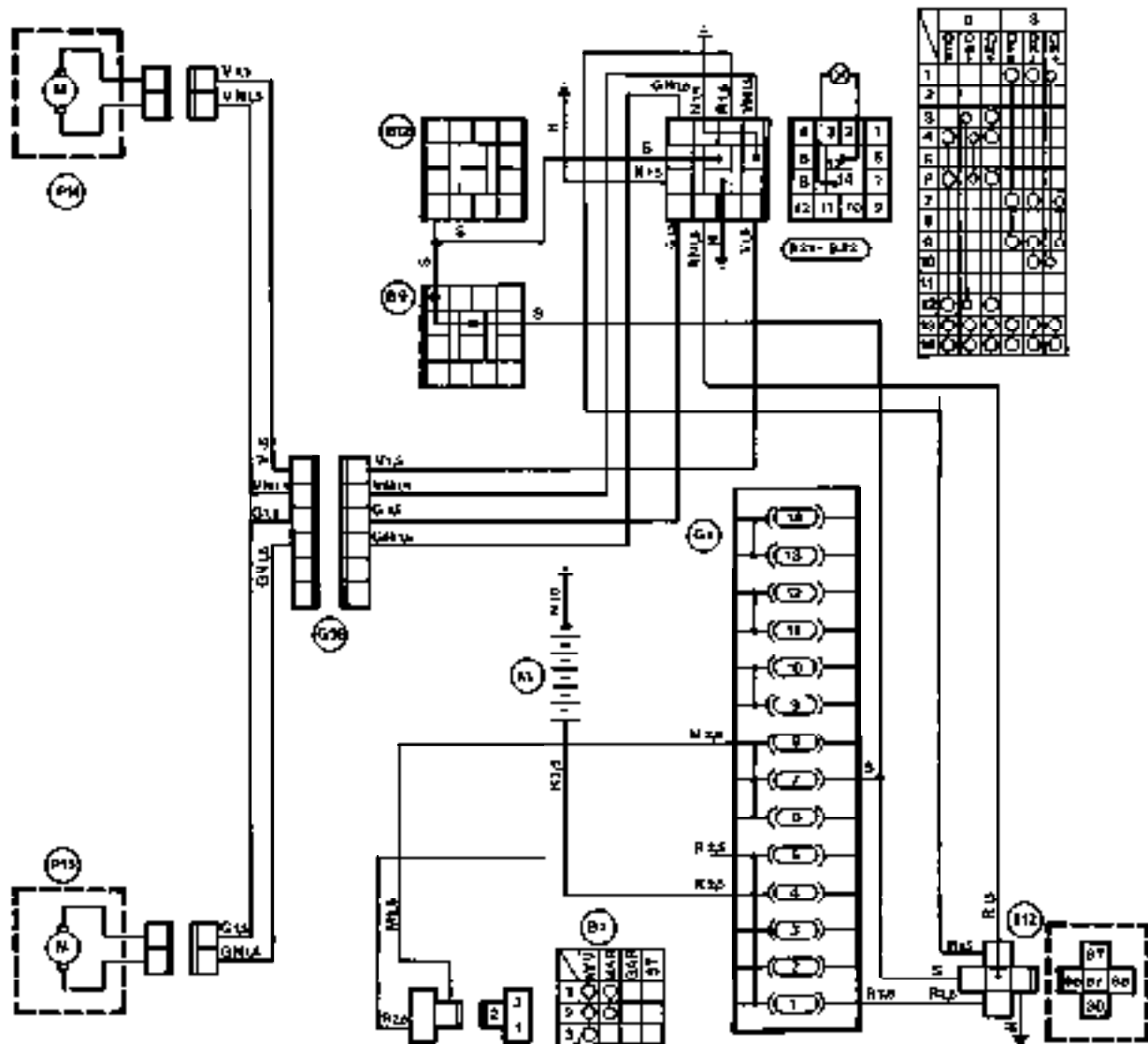

- A1 Battery
- B1 Ignition switch
- B9 Heated rear window control switch
- B12 Hazard lights control switch

- B21 Right front power window control switch
- B22 Left front power window control switch
- G1 Fusebox
- G36 Power window switch cable connector

- I12 Front power windows relay
- P14 Right front power window motor
- PI 5 Left front power window motor

ELECTRICAL SYSTEM

POWER WINDOWS AND DOOR LOCKS

1500 **Quadrifoglio** model

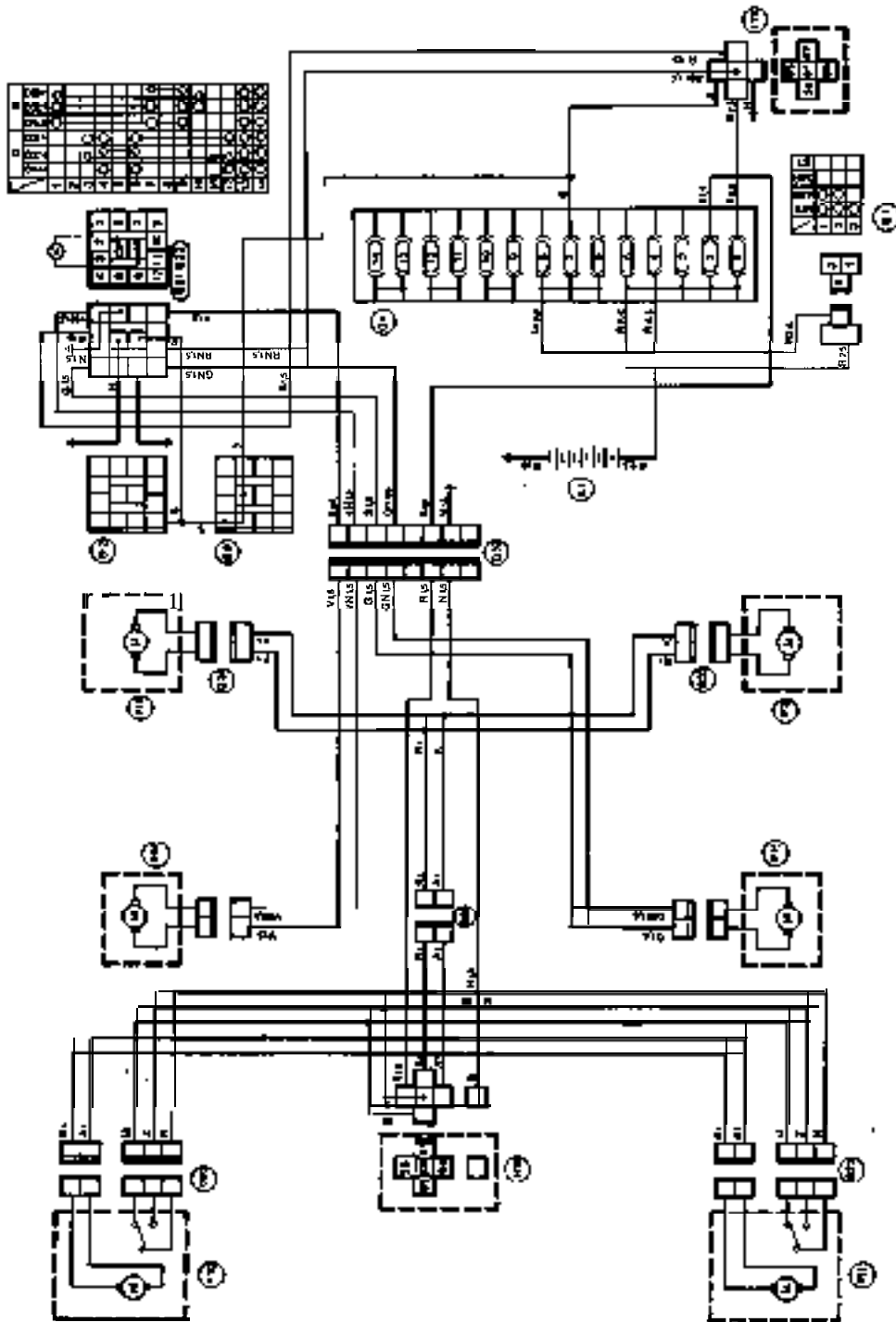

- A1 Battery
- B1 Ignition switch
- B8 Hazard rear window control switch
- B12 Hazard lights control switch
- B21 Right front power window control switch
- B22 Left front power window control switch
- G1 Fusebox
- G20 Right front door lock motor connector
- G22 Left front door lock motor connector
- G24 Right rear door lock motor connector
- G26 Left rear door lock motor connector
- G30 Speed window and door lock connector
- G37 Rear door lock motor connector
- I12 Front power windows relay
- N11 Door lock control unit
- P10 Right front door lock motor
- P12 Left front door lock motor
- P14 Right rear door lock motor
- P16 Left rear power window motor

DOOR LOCK CONTROL UNIT

LOCATION

The door lock control unit is located inside passenger compartment, in the gear lever console, behind Check Control and Trip Computer.

REMOVAL AND INSTALLATION

1. Withdraw instrument holder (3) and disconnect the relevant harness.

2. Remove control unit (1) by unscrewing the screw securing it to Trip Computer (2).

For control unit installation, reverse order of removal.

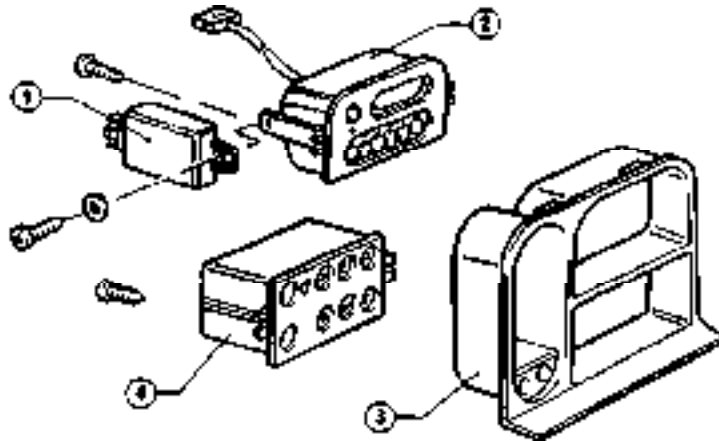

- 1 Door lock control unit
- 2 Trip Computer
- 3 Instrument holder
- 4 Check Control

LOCATION

Check Control and Trip Computer are inserted into a special instrument holder integrated into gear lever console, in centre position, under dashboard.

REMOVAL AND INSTALLATION

1. Withdraw instrument holder 3 from console and disconnect the relevant harness.
2. Remove Check Control 2 and Trip Computer 1 by unscrewing, for each one, the two securing screws to instrument holder.

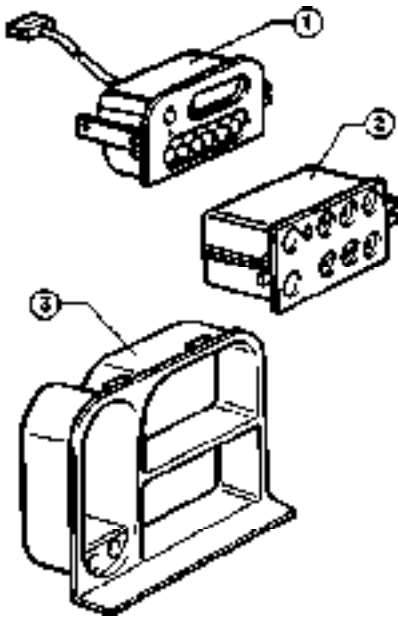

1 Trip Computer 3 Instrument holder
2 Check Control

3. For instrument installation, reverse order of removal. When reading a red led diode is

used to set in evidence the enabled function in order to allow user an easy identification.

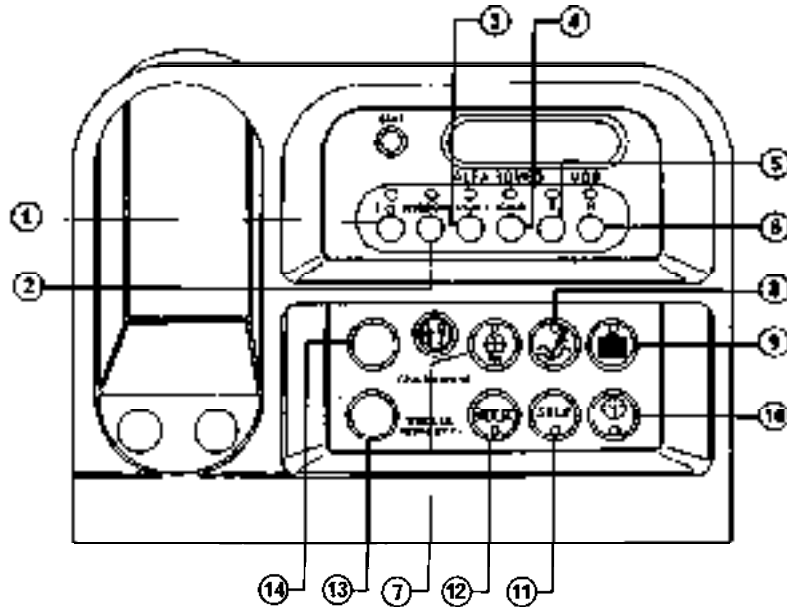

For an easier comprehension of the symbology used for the two instruments, in the following table reference is made to Trip Computer

Indications and the Check Control signalings, pairing them to relevant symbols.

Trip Computer	Check Control
1 Istantaneous consumption in L/100 km	7 Windscreen washer fluid level warning lamp
2 Medium consumption for the covered distance in L/100 km starting from zeroing by red Key (Start Key)	8 Engine oil level warning lamp
3 Fuel consumption in litres since trip start, starting from zeroing by red Key	9 Engine coolant level warning lamp
4 Medium speed in km/h since trip start, starting from zeroing by red Key	10 Cluster warning lamp
5 Drive time in h/min since trip start, starting from zeroing by red Key	11 Stop lights warning lamp
6 Time in hours/min	12 Side lights warning lamp
	13 Main red warning lamp
	14 Main green warning lamp

ELECTRIC COMPONENT LOCATION

ENGINE COMPARTMENT

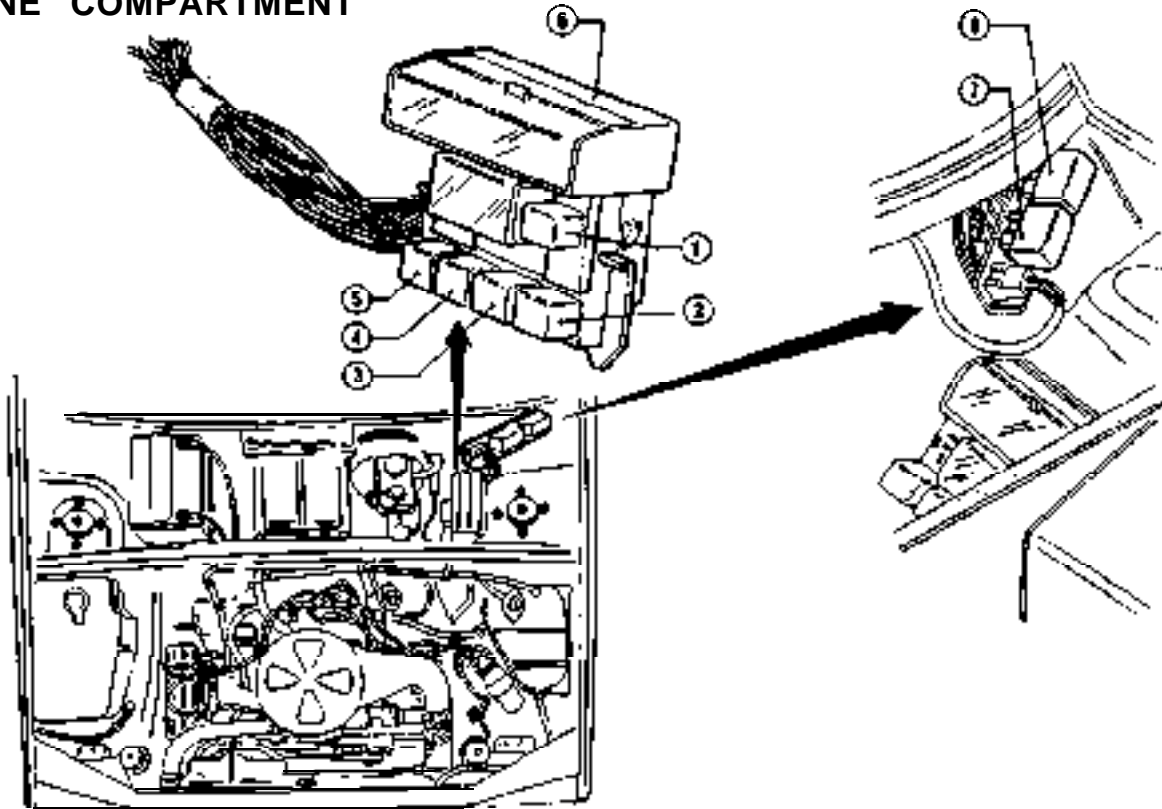

- 1 Passenger compartment roof lamp timer
- 2 Horns relay
- 3 Heated rear window relay
- 4 Headlight wiper relay

- 5 Front power windows relay
- 6 Fusebox
- 7 Electronic device for headlights and flashing changeover
- 8 Windscreen wiper electronic intermittence

PASSENGER COMPARTMENT

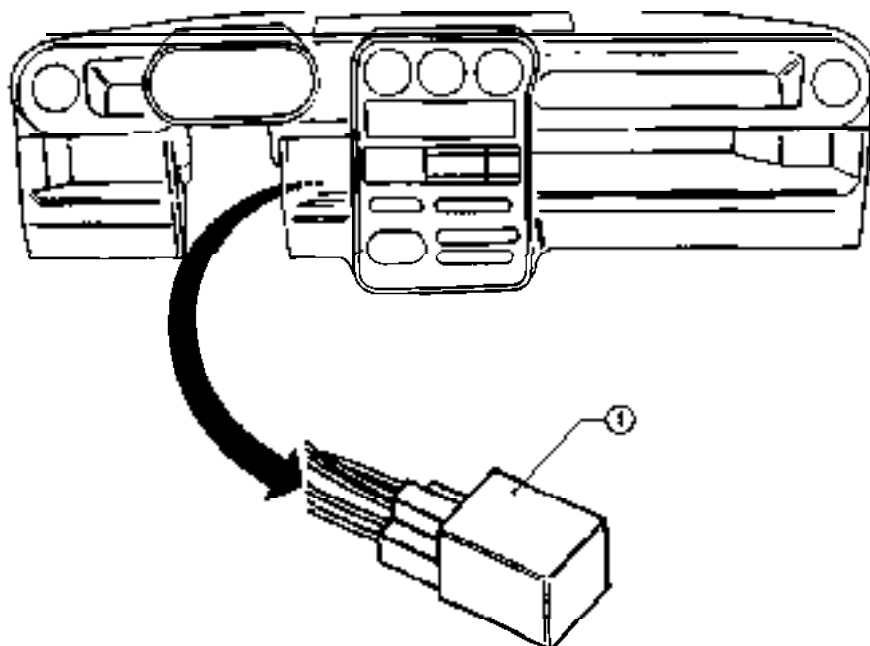

- 1 Hazard and direction lights intermittence

HARNESS LAYOUT

GENERAL HARNESS

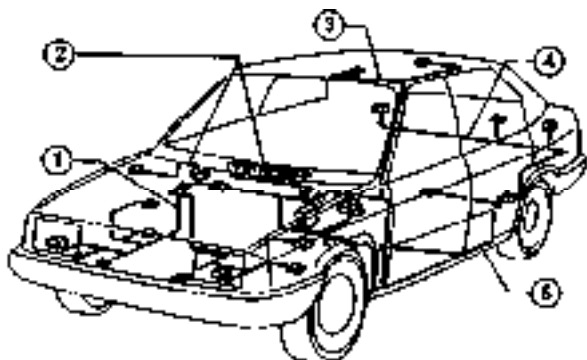

- 1 Engine compartment harness
- 2 Front part and dashboard harness
- 3 Roof lamp harness
- 4 Luggage room harness
- 5 Passenger compartment harness

ENGINE COMPARTMENT

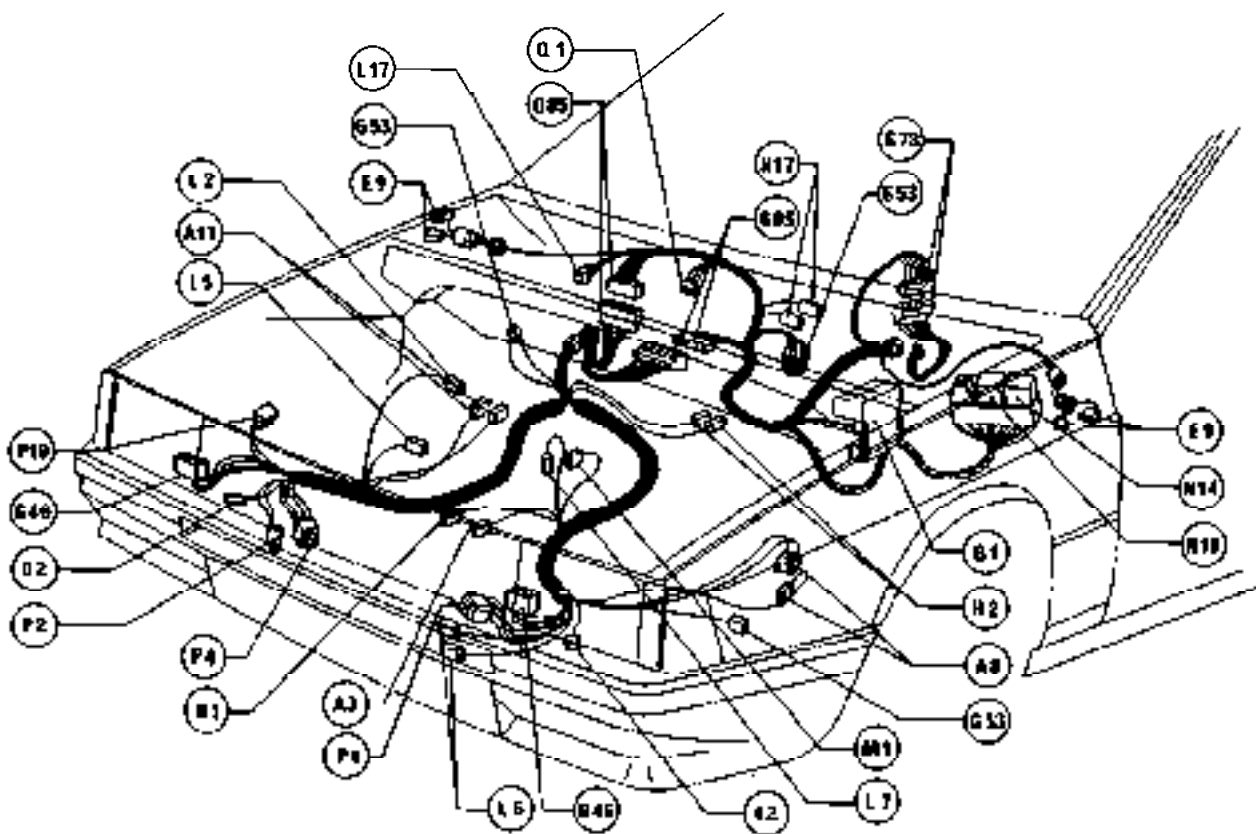

- A3 Alternator with built-in electronic regulator
- A8 Ignition coil
- A1 1 Starter
- D1 Alternator charge warning lamp
- E9 Side direction light lamp
- G1 Fusebox
- G46 Headlight connector
- G53 Engine compartment ground
- G73 Rear service connector
- G85 Front service connector
- H2 Reverse right switch
- H17 Brake fluid min. level control switch
- L2 Pressure switch for engine oil min. pressure

- L5 Thermostatic switch for engine coolant max. temperature warning lamp
- L6 Thermostatic switch for engine cooling electric fan
- L7 Transmitter for coolant temperature gauge
- L17 Odometer pulse generator
- M1 Cut-off solenoid valve
- N14 Windscreen wiper electronic intermittence
- N18 Electronic device for headlights and flashing changeover
- O2 Horn
- P2 Engine cooling electric fan
- P4 Headlight wiper motor
- P19 Windscreen washer electric pump
- Q1 Air ventilation heater fan

PASSENGER COMPARTMENT AND LUGGAGE ROOM (L.H. DRIVE)

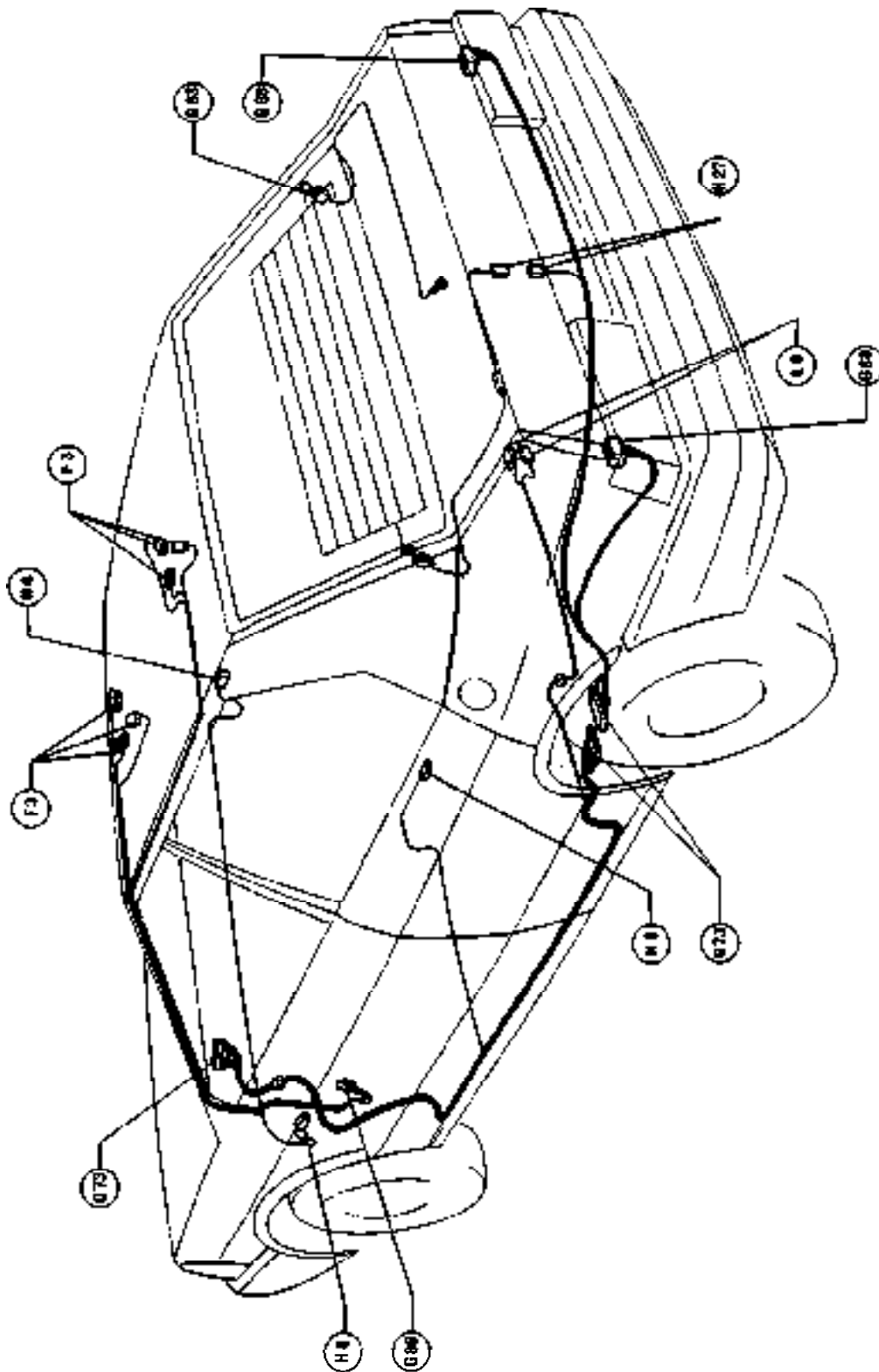

- H1 Headlight switch
- H4 Floor lamp switch on passenger compartment pillar
- H27 Contact switch on rear door for heated rear window
- LB Transmitter for fuel level gauge

- P3 Passenger compartment rear lamp
- G63 Rear ground
- G73 Rear service connector
- G66 Passenger compartment rear lamp connector
- G68 Tail light connector

DASHBOARD (L.H. DRIVE)

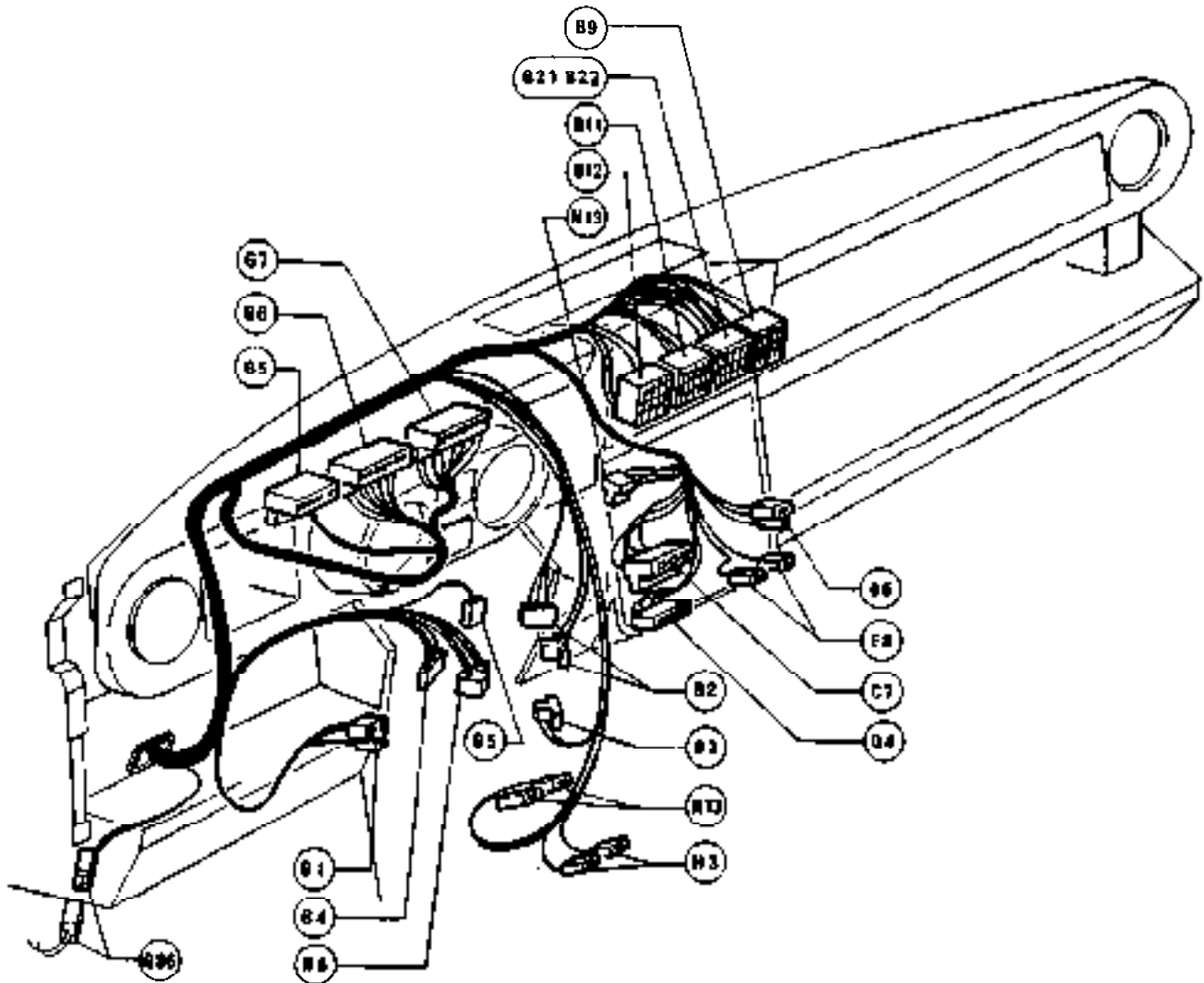

- | | |
|-------------------------------------------------------------------|-----------------------------------------------|
| B1 Ignition switch | F8 Air ventilation controls lighting lamp |
| B2 Windscreen wiper control switch | G5 Connector |
| B4 Control switch for headlight, flashing, low beam and full beam | G6 Cluster B connector |
| B5 Horns control switch | G7 Cluster R connector |
| B6 Direction lights indicator switch | G86 Passenger compartment roof lamp connector |
| B9 Heated rear window control switch | H3 Stop light switch |
| B11 Rear fog light control switch | H13 Choke switch |
| B12 Hazard lights control switch | N13 Hazard and direction lights intermittence |
| B21 Right front power window control switch | Q6 Cigar lighter |
| B22 Left front power window control switch | Q4 Air ventilation heater fan control |
| C7 Clock | |

SWITZERLAND-AUSTRALIA MODEL VARIATION

TACHYMETRIC CONTROL UNIT-FAST IDLE ELECTROMAGNET -HAND BRAKE SWITCH

TACHYMETRIC CONTROL UNIT - FAST IDLE/ ELECTROMAGNET

(For vehicles 1350 - 1500 and 1500 Quadrifoglio models for SWITZERLAND and AUSTRALIA)
and HAND BRAKE SWITCH

(For 1500 Quadrifoglio vehicles, AUSTRALIA models)

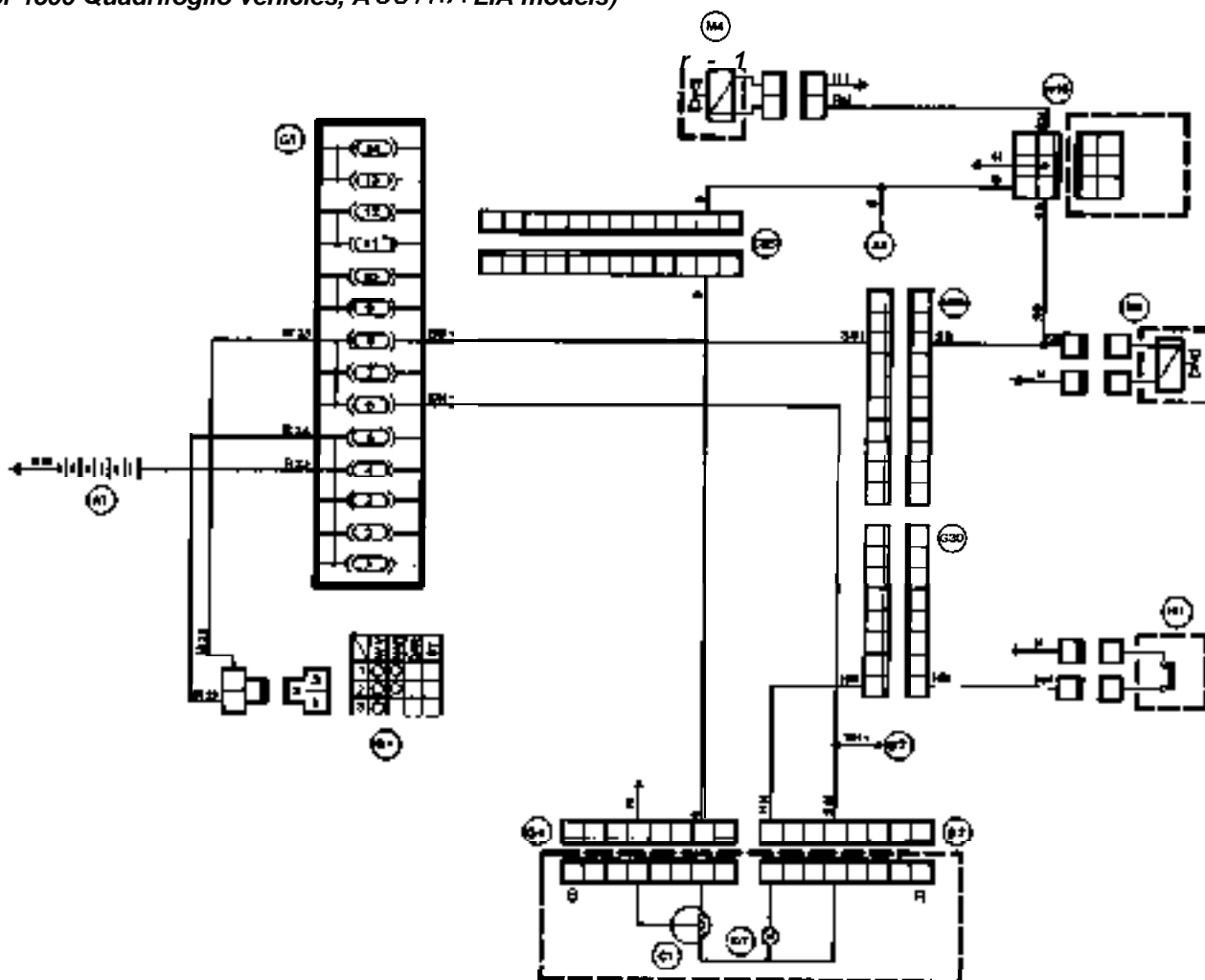

- A1 Battery
- A8 Ignition coil
- B1 Ignition switch
- B2 Windscreen wiper control switch
- C1 Electronic rev. counter
- D7 Hand brake warning lamp
- G1 Fusebox
- G6 Cluster B connector

- G7 Cluster R connector
- G30 Power window and door lock connector
- G85 Front service connector
- H1 Hand brake switch
- M1 Cut-off solenoid valve
- M4 Idle speed electromagnet
- N16 Tachymetric control unit

HANDBRAKE INDICATOR SWITCH (1500 Quadrifoglio)

Check

1. Set the ignition key to the MAR position.
2. Connect a tester to terminal of

- handbrake indicator as shown in figure.
3. The following resistance values shall be read.

- Brake engaged: 0Ω
- Brake disengaged: $\infty \Omega$

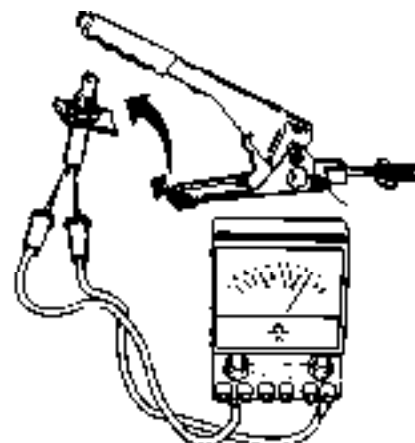

CIRCUIT DIAGRAM

KEY

A	Battery	H2	Reverse light switch
A3	Alternator with built-in electronic regulator	H3	Stop light switch
A5	Ignition distributor	H4	Roof lamp switch on passenger compartment pillar
A8	Ignition coil	H13	Choke switch
All	Starter	H17	Brake fluid min. level control switch
A12	Spark plugs	H27	Contact switch, on rear door, for heated rear window
B1	Ignition switch	I2	Heated rear window relay
B2	Windscreen wiper control switch	I3	Horns relay
B3	Windscreen washer and/or headlight wash/wiper pump control switch	I4	Headlight wiper relay
B4	Control switch for headlight, flashing, low beam and full beam	I12	Front power windows relay
B5	Horns control switch	L2	Pressure switch for engine oil min. pressure
B6	Direction lights indicator switch	L5	Thermostatic switch for engine coolant max. temperature warning lamp
B9	Heated rear window control switch	L6	Thermostatic switch for engine cooling electric fan
B11	Rear fog light control switch	L7	Transmitter for coolant temperature gauge
B12	Hazard lights control switch	L9	Transmitter for fuel level gauge
B21	Right front power window control switch	L12	Engine oil level indicator
B22	Left front power window control switch	L13	Windscreen washer liquid level sensor
C1	Electronic rev. counter	L14	Engine coolant level sensor
C2	Electronic tachometer	L17	Odometer pulse generator
C4	Fuel level gauge	M1	Cut-off solenoid valve
C6	Coolant temperature gauge	M4	Idle speed electromagnet
C7	Clock	N1	Module for electronic ignition
D1	Alternator charge warning lamp	N7	Trip Computer
D2	Direction light warning lamp	N8	Check Control
D3	Side light warning lamp	N10	Passenger compartment roof lamp timer
D4	Full beam warning lamp	N11	Door lock control unit
D5	Brake fluid level warning lamp	N13	Hazard and direction lights intermittence
D7	Hand brake warning lamp	N14	Windscreen wiper electronic intermience
D8	Fuel reserve warning lamp	N16	Tachymetric control unit
D9	Choke warning lamp	N17	Trip control unit for fuel flow
D11	Engine oil min. pressure warning lamp	N18	Electronic device for headlights and flashing changeover
D13	Engine coolant max. temperature warning lamp	01	Heated rear window
E1	Front direction indicator light lamp	02	Horn
E2	Front side light lamp	06	Cigar lighter
E8	Low beam and full beam lamp	P1	Windscreen wiper motor
E9	Side direction light lamp	P2	Engine cooling electric fan
E11	Rear direction light lamp	P4	Headlight wiper motor
E13	Tail light lamp	P10	Right front dwr lock motor
E14	Reverse light lamp	P11	Left front door lock motor
E15	Stop light lamp	P12	Right rear door lock motor
E16	Rear fog light lamp	P13	Left rear door lock motor
E17	Number plate light lamp	P14	Right front power window motor
F3	Passenger compartment roof lamp	P15	Left front power window motor
F8	Air ventilation controls lighting lamp	P19	Windscreen washer electric pump
F12	Cluster lighting lamp	P20	Headlight washer electric pump
F16	Ignition switch lighting lamp	Q1	Air ventilation heater fan
F17	Switches lighting lamp	Q4	Air ventilation heater fan control
G1	Fusebox	Q.1	L.H.D. 1200 model
H1	Handbrake switch	Q.2	L.H.D. - R.H.D. 1350 model
		Q.3	L.H.D. - R.H.D. 1500 model
		Q.4	L.H.D. - R.H.D. 1500 Quadrifoglio model

ELECTRICAL SYSTEM

CIRCUIT DIAGRAM - 1200 and 1300 MODELS

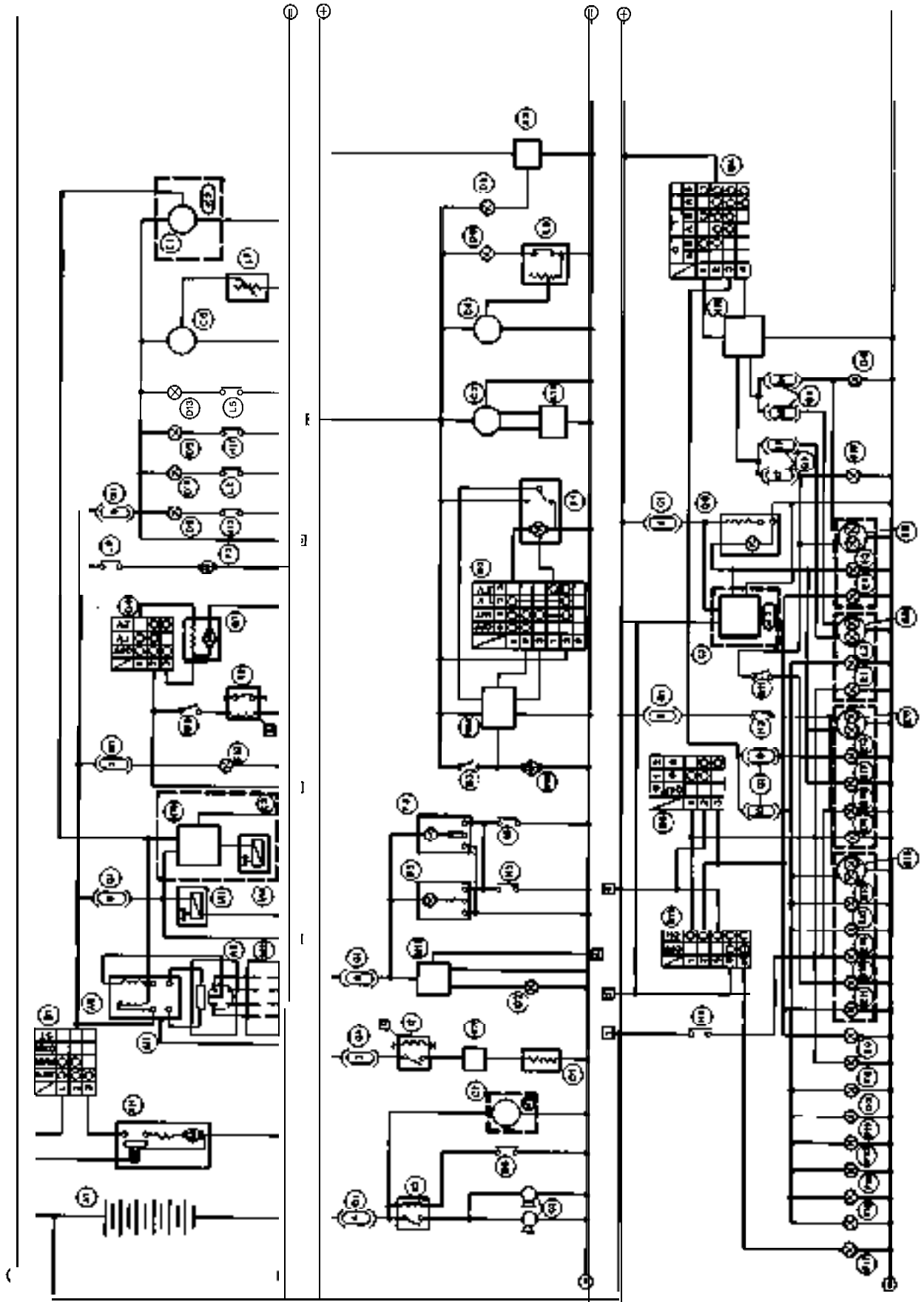

CIRCUIT DIAGRAM - 3540 and 1800 QUADRIPOLE MODELS

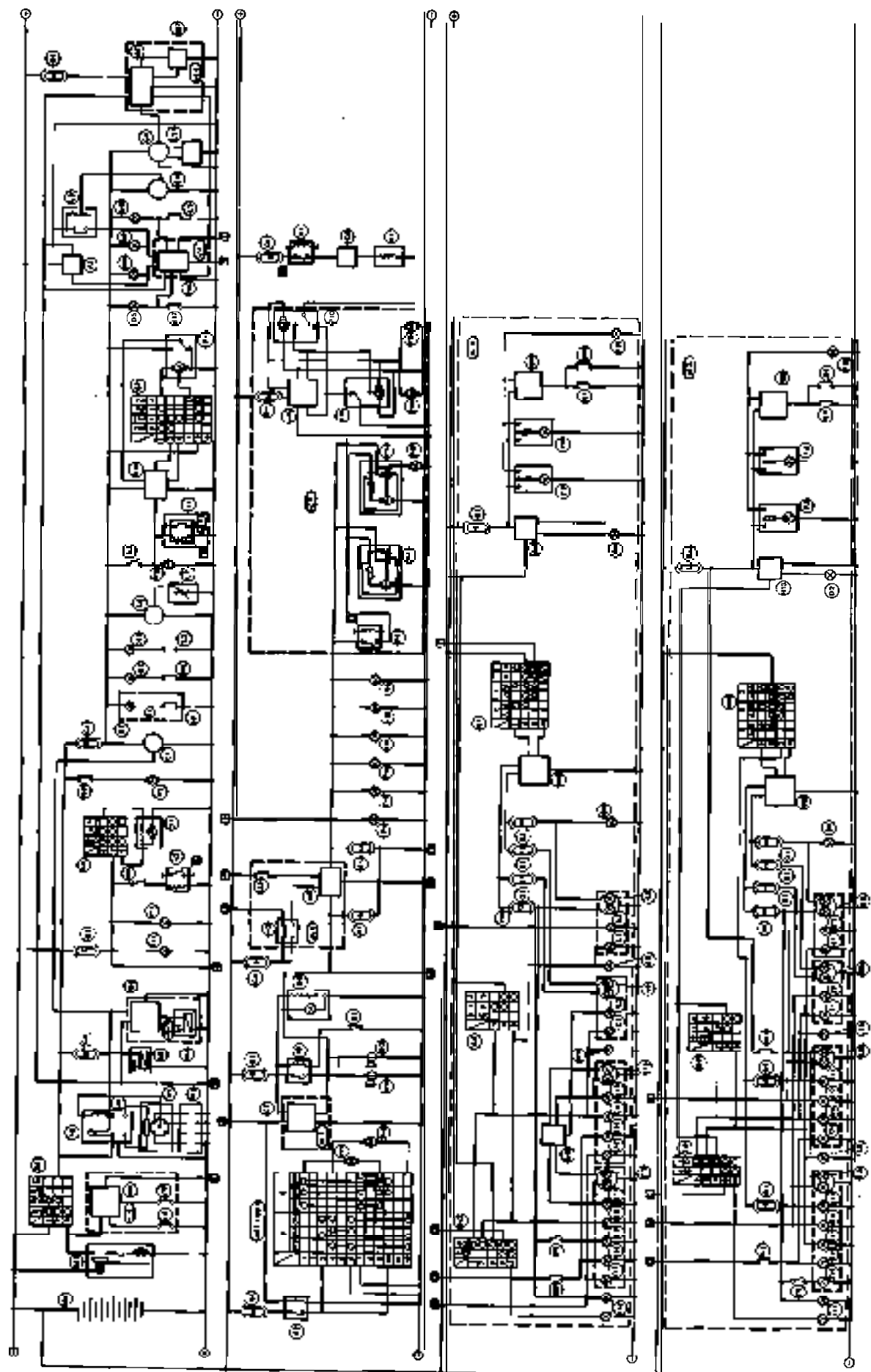

ELECTRICAL SYSTEM

KEY

A1	Battery	H2	Reverse light switch
A3	Alternator with built-in electronic regulator	H3	Stop light switch
A5	ignition distributor	H4	Roof lamp switch on passenger compartment pillar
A8	Ignition coil	HI 3	Choke switch
All	Starter	H17	Brake fluid min. level control switch
AI 2	Spark plugs	H27	Contact switch, on rear door, for heated rear window
B1	Ignition switch	I2	Heated rear window relay
B2	Windscreen wiper control switch	I3	Horns relay
B3	Windscreen washer and/or headlight wash/wiper pump control switch	I4	Headlight wiper relay
B4	Control switch for headlight, flashing, low beam and full beam	I12	Front power windows relay
B5	Horns control switch	L2	Pressure switch for engine oil min. pressure
B6	Direction lights indicator switch	L5	Thermostatic switch for engine coolant max. temperature warning lamp
B9	Heated rear window control switch	L6	Thermostatic switch for engine cooling electric fan
B11	Rear fog light control switch	L7	Transmitter for coolant temperature gauge
B12	Hazard lights control switch	L9	Transmitter for fuel level gauge
B21	Right front power window control switch	L12	Engine oil level indicator
B22	Left front power window control switch	L13	Windscreen washer liquid level sensor
C1	Electronic rev. counter	L14	Engine coolant level sensor
c2	Electronic tachometer	L17	Odometer pulse generator
c4	Fuel level gauge	M1	Cut-off solenoid valve
C6	Coolant temperature gauge	M4	Idle speed electromagnet
c7	Clock	N1	Module for electronic ignition
D1	Alternator charge warning lamp	N7	Trip Computer
D2	Direction light warning lamp	N8	Check Control
D3	Side light warning lamp	N10	Passenger compartment roof lamp timer
D4	Full beam warning lamp	N11	Door lock control unit
D5	Brake fluid level warning lamp	N13	Hazard and direction lights intermittence
D7	Hand brake warning lamp	N14	Windscreen wiper electronic intermittence
D8	Fuel reserve warning lamp	N16	Tachymetric control unit
D9	Choke warning lamp	N17	Trip control unit for fuel flow
D11	Engine oil min. pressure warning lamp	N18	Electronic device for headlights and flashing changeover
D13	Engine coolant max. temperature warning lamp	O1	Heated rear window
E1	Front direction indicator light lamp	O2	Horn
E2	Front side light lamp	O6	Cigar lighter
E8	Low beam and full beam lamp	P1	Windscreen wiper motor
E9	Side direction light lamp	P2	Engine cooling electric fan
E1 1	Rear direction light lamp	P4	Headlight wiper motor
E13	Tail light lamp	P10	Right front door lock motor
E14	Reverse light lamp	P11	Left front door lock motor
E15	Stop light lamp	P12	Right rear door lock motor
E16	Rear fog light lamp	P13	Left rear door lock motor
E17	Number plate light lamp	P14	Right front power window motor
F3	Passenger compartment roof lamp	P15	Left front power window motor
F8	Air ventilation controls lighting lamp	P19	Windscreen washer electric pump
F12	Cluster lighting lamp	P20	Headlight washer electric pump
F16	Ignition switch lighting lamp	Q1	Air ventilation heater fan
F17	Switches lighting lamp	Q4	Air ventilation heater fan control
G1	Fusebox	Q1	L.H.D. 1200 model
HI	Handbrake switch	a2	L.H.D. - R.H.D. 1350 model
		a3	L.H.D. - R.H.D. 1500 model
		a4	L.H.D. - R.H.D. 1500 Quadrifoglio model

BODY-SHEET METAL PANELS

GROUP 49

CONTENTS

GENERAL INFORMATION.,	49-2	Symbology	49-21
Identification codes	49-2	Removal and installation	
Lifting points.	49-3	procedures	49-22
Wheel alignment.	49-3	Radiator core support	49-29
BODY COMPONENT PARTS	49-5	Hoodledge panel with core	
Body components	49-5	support removed	49-31
Under body components	49-6	Hoodledge panel with radiator core	
BODY CONSTRUCTION	49-7	support removed (Partial	
Body construction	49-7	replacement)	49-33
BODY SEALING	49-9	Front side member.	49-35
Description.	49-9	Central pillar	49-37
BODY ALIGNMENT	49-11	Outer side member.	49-39
Measurement operations	49-11	Outer side member (Partial	
Measurement points.	49-12	replacement)	49-41
CAUTIONS FOR THE OPERATORS ..	49-14	Rear fender	49-43
Safety rules	49-14	Drip with rear fender removed.	49-45
Body and outer components		Lower rear panel	49-46
protections.	49-14	Upper rear panel	49-47
Cautions during replacement		Rear part of rear floor with rear fender	
operations	49-15	and rear panel removed	49-49
Cautions during welding operations ..	49-15	Rear side member with rear panel	
REPLACEMENT OPERATIONS	49-20	and rear floor removed.	49-51
How to read this chapter	49-20	Roof panel.	49-52

GENERAL INFORMATION

IDENTIFICATION DATA

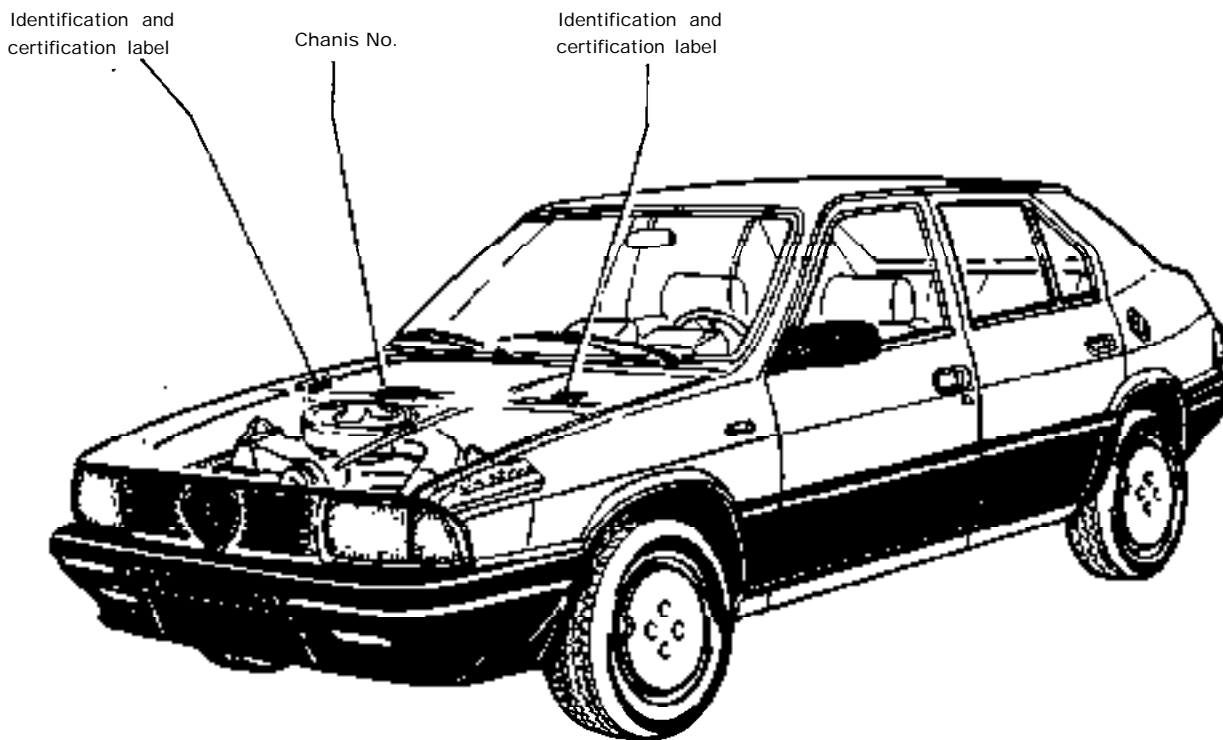

Identification and
certification label

Chassis No.

Identification and
certification label

Identification and-certification label

See Group 00 - Identification Data

Chassis no.

(according to CEE/ISO standard specifications)

See Group 00 - Identification Data

LIFTING POINTS

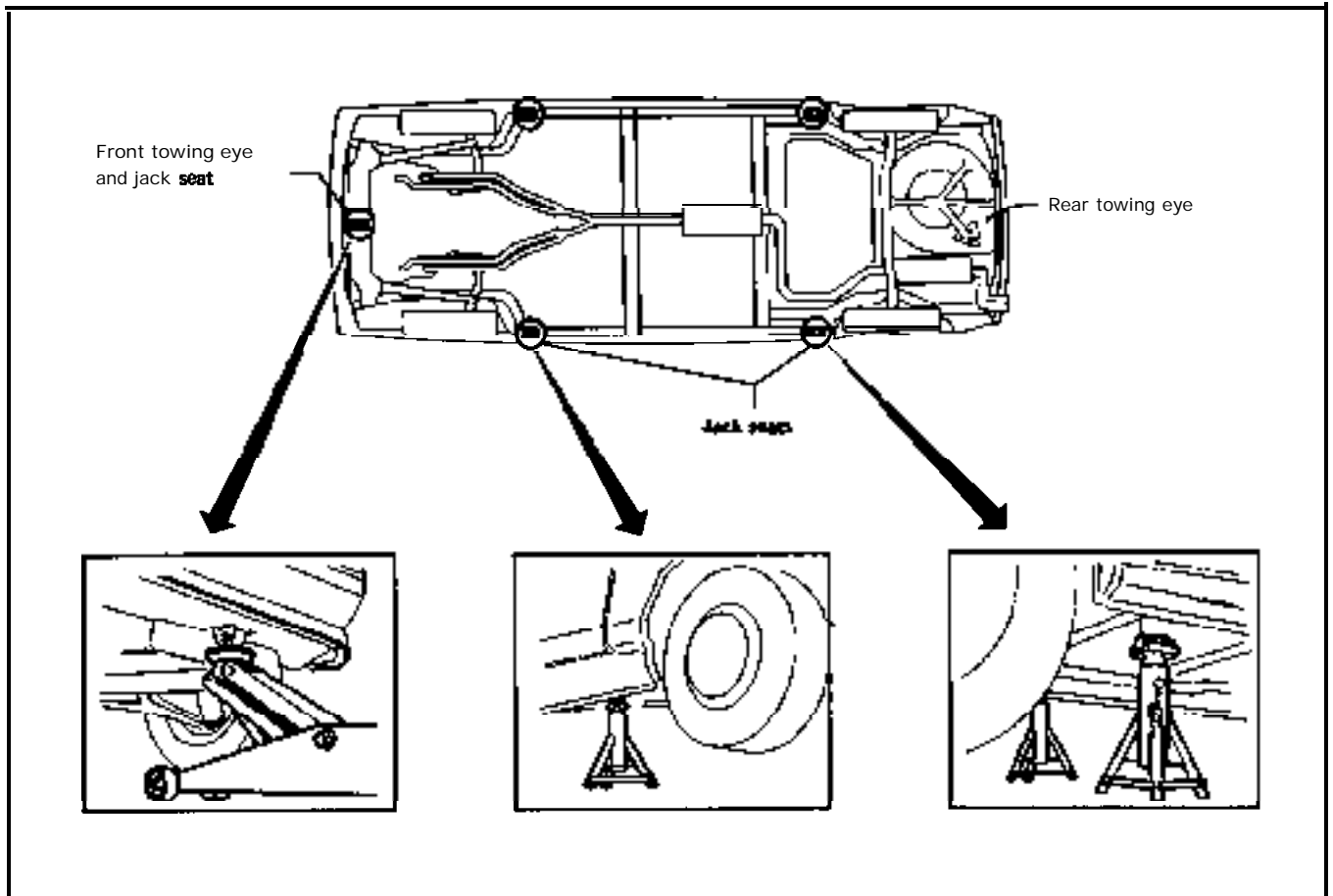

Jack and safety stands

WARNING:

- a. After lifting the car by means of hydraulic jack, provide to support car weight by means of safety stands.
- b. Before lifting car rear (front) side place wheel chocks by positioning them at front (rear) wheels.

Securely position hydraulic jack and safety stands in the points identified in figure.

WHEEL ALIGNMENT

CAUTION:

The technicians assigned to the repair and replacement operations of sheet panels, shall always take into account, content of the remaining part of the "Workshop Manual" in order always to maintain original quality and functioning conditions of car as a whole. As restoration of car correct alignment is of particular importance, in the following part are provided the data relevant to geometry of both front and rear suspensions. For any further information, refer to the specific Groups.

1. Front axle and suspension

Toe-out	mm (in)	$M - H = 4 \pm 1$ $M - H = 0.16 \pm 0.04$
Half toe-out	mm (in)	$L = \frac{1}{2} M - 2 \pm 0.5$ $L = \frac{1}{2} M - 0.08 \pm 0.02$
Toe-out angle		$\alpha = 10'$
Rim diameter	mm (in)	$\emptyset = 340$ $\emptyset = 13.39$
Camber angle		$\beta = -2^{\circ}15' \pm 30'$
Caster angle		$\gamma = 1^{\circ} \pm 30'$
Max steering angle		$\delta = 3350'$

2. Rear axle and suspension

Toe-in angle		$\alpha = 0^{\circ} \pm 25'$
Camber angle		$\beta = 0^{\circ} \pm 25'$

Wheel alignment is measured with car under nominal height (see: Group 00 - Wheel alignment).

BODY COMPONENT PARTS

BODY COMPONENTS

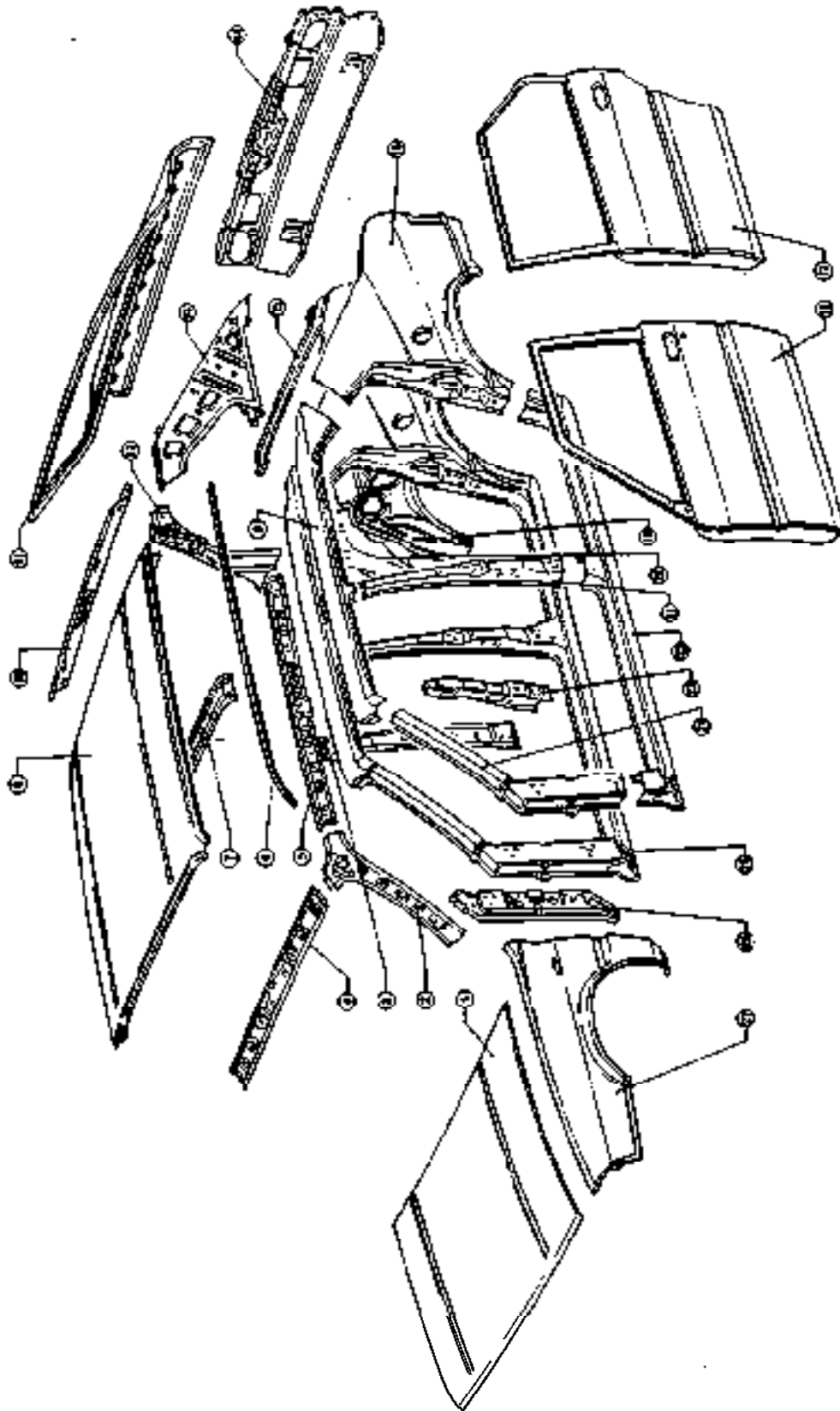

- 1 Floor
- 2 Body front pillar
- 3 Body support pillar
- 4 Windshield area access member
- 5 Body left lower upper edge
- 6 Body
- 7 Control station
- 8 Body shell
- 9 Body side upper member

- 10 Back door of bed support
- 11 Bed door
- 12 Bed rest, rear back support bracket
- 13 Floor support frame
- 14 Floor trim assembly
- 15 Floor frame, rhd
- 16 Bed support
- 17 Bed edge member
- 18 Front door assembly

- 19 Outer side window
- 20 Outer side window
- 21 Glass plate
- 22 Outer side window
- 23 Control panel, temperature indicator
- 24 Glass plate
- 25 Body side
- 26 Front side window frame
- 27 Front window

UNDER BODY COMPONENTS

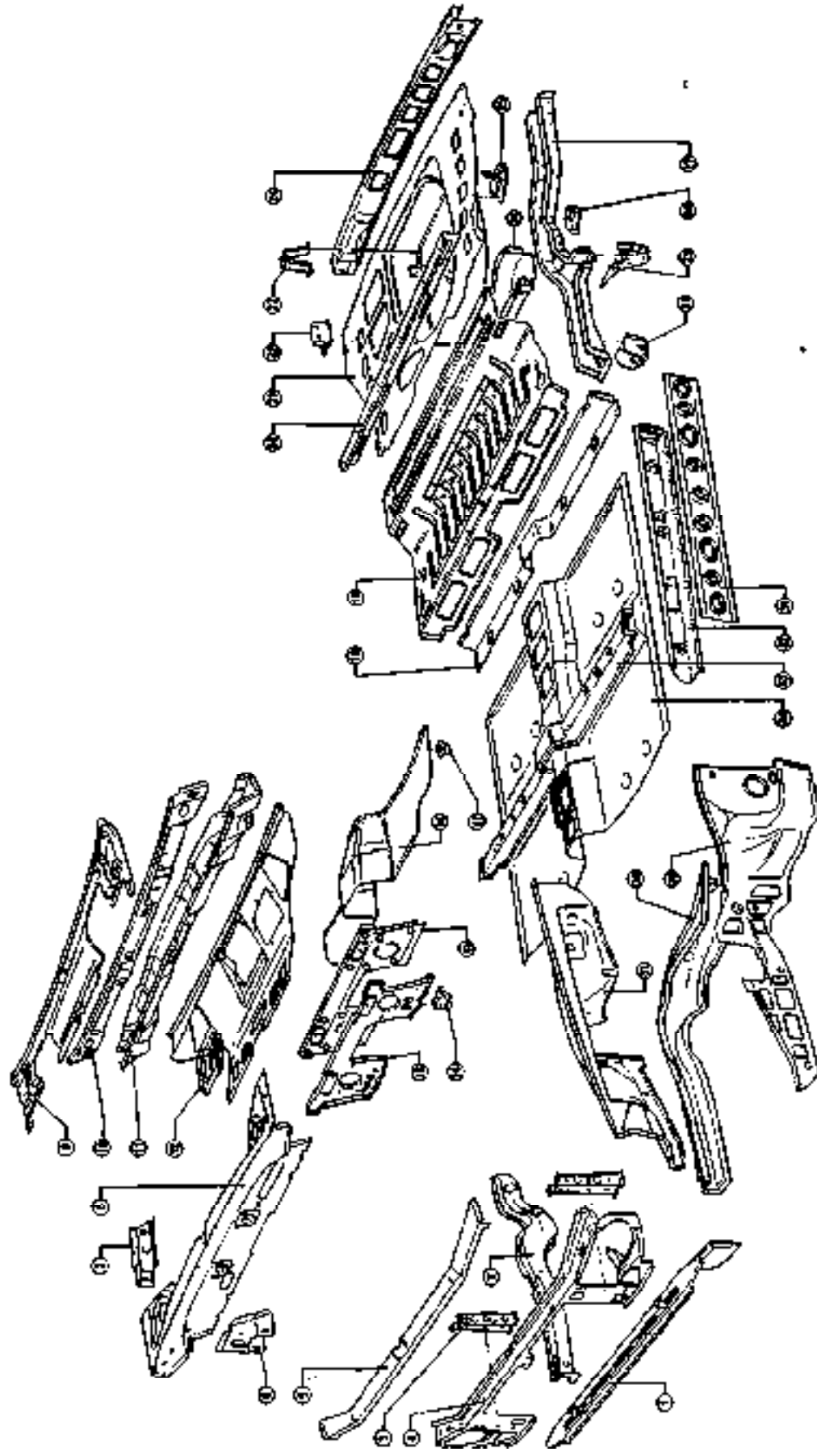

- 1 Lower front cross member
- 2 Lower front cross member
- 3 Front sheet metal floor pan
- 4 Front sheet metal floor pan
- 5 Front sheet metal floor pan
- 6 Front sheet metal floor pan
- 7 Front sheet metal floor pan
- 8 Front sheet metal floor pan
- 9 Front sheet metal floor pan
- 10 Front sheet metal floor pan

- 11 Air clear assembly
- 12 Air clear assembly
- 13 Air clear assembly
- 14 Air clear assembly
- 15 Air clear assembly
- 16 Air clear assembly
- 17 Air clear assembly
- 18 Air clear assembly
- 19 Air clear assembly

- 20 Rear floor spring plate
- 21 Rear floor spring plate
- 22 Rear floor spring plate
- 23 Rear floor spring plate
- 24 Rear floor spring plate
- 25 Rear floor spring plate
- 26 Rear floor spring plate
- 27 Rear floor spring plate
- 28 Rear floor spring plate
- 29 Rear floor spring plate
- 30 Rear floor spring plate
- 31 Rear floor spring plate

- 32 Rear suspension (left) bar member
- 33 Rear suspension (right) bar member
- 34 Rear suspension (left) bar member
- 35 Rear suspension (right) bar member
- 36 Rear suspension (left) bar member
- 37 Rear suspension (right) bar member
- 38 Rear suspension (left) bar member
- 39 Rear suspension (right) bar member
- 40 Rear suspension (left) bar member
- 41 Rear suspension (right) bar member
- 42 Rear suspension (left) bar member
- 43 Rear suspension (right) bar member
- 44 Rear suspension (left) bar member
- 45 Rear suspension (right) bar member
- 46 Rear suspension (left) bar member
- 47 Rear suspension (right) bar member
- 48 Rear suspension (left) bar member
- 49 Rear suspension (right) bar member
- 50 Rear suspension (left) bar member
- 51 Rear suspension (right) bar member

BODY CONSTRUCTION

BODY CONSTRUCTION

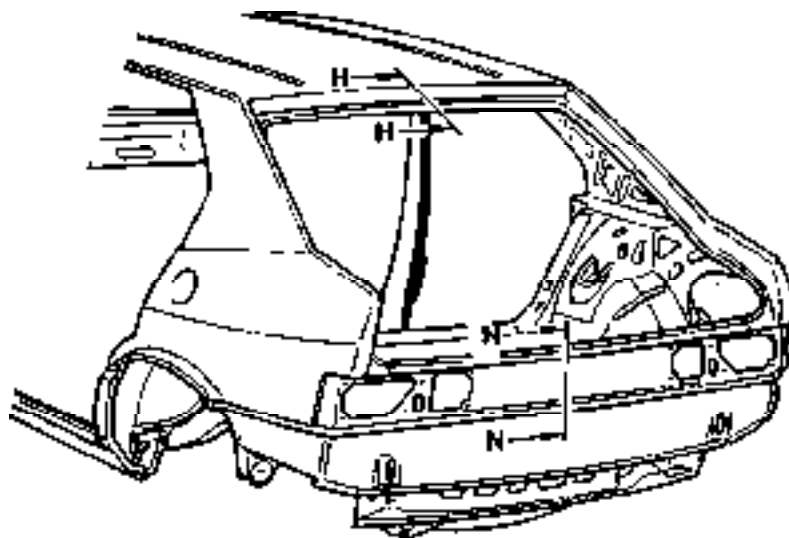
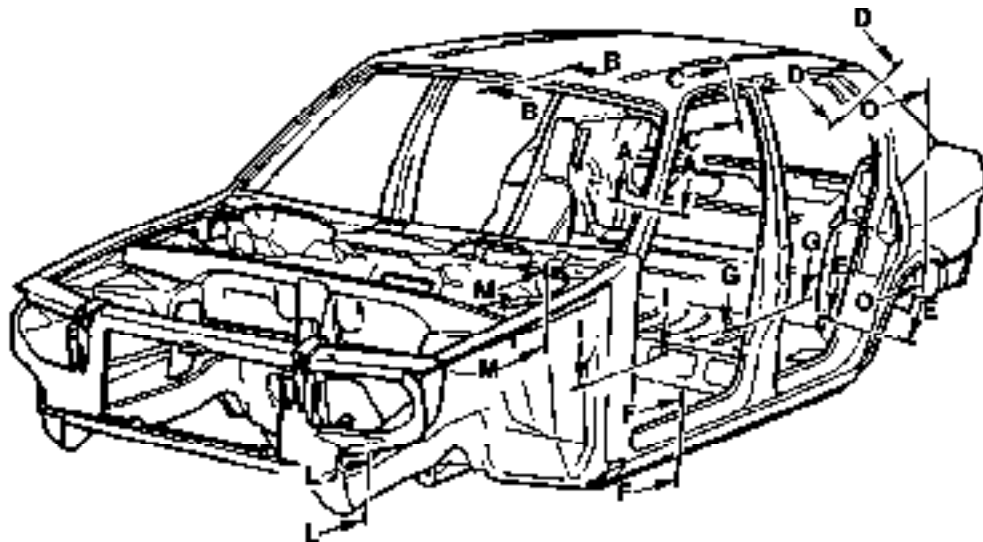

BODY SEALING

DESCRIPTION

The following figures, show the body areas which are sealed by Manufacturer.

The sealings applied to these areas, must be smooth and free from scratches or gaps.

Take care not to apply too much sealing and not to allow other unaffected parts to come in contact with the sealing.

Body components sealing

Paint seal, after priming or painting, and then sleek by means of a brush along all sheet joints in order to remove

possible sealing faults.

ICIR: Paraflex Alpha 3M
8531 /E
8536/E

Alternative: part. no. 3522-00014

Sealant for bolted joints

Sealant for joints between panels assembled by bolting.

3M - Autosealer 8573E - part. no. 3522-00045

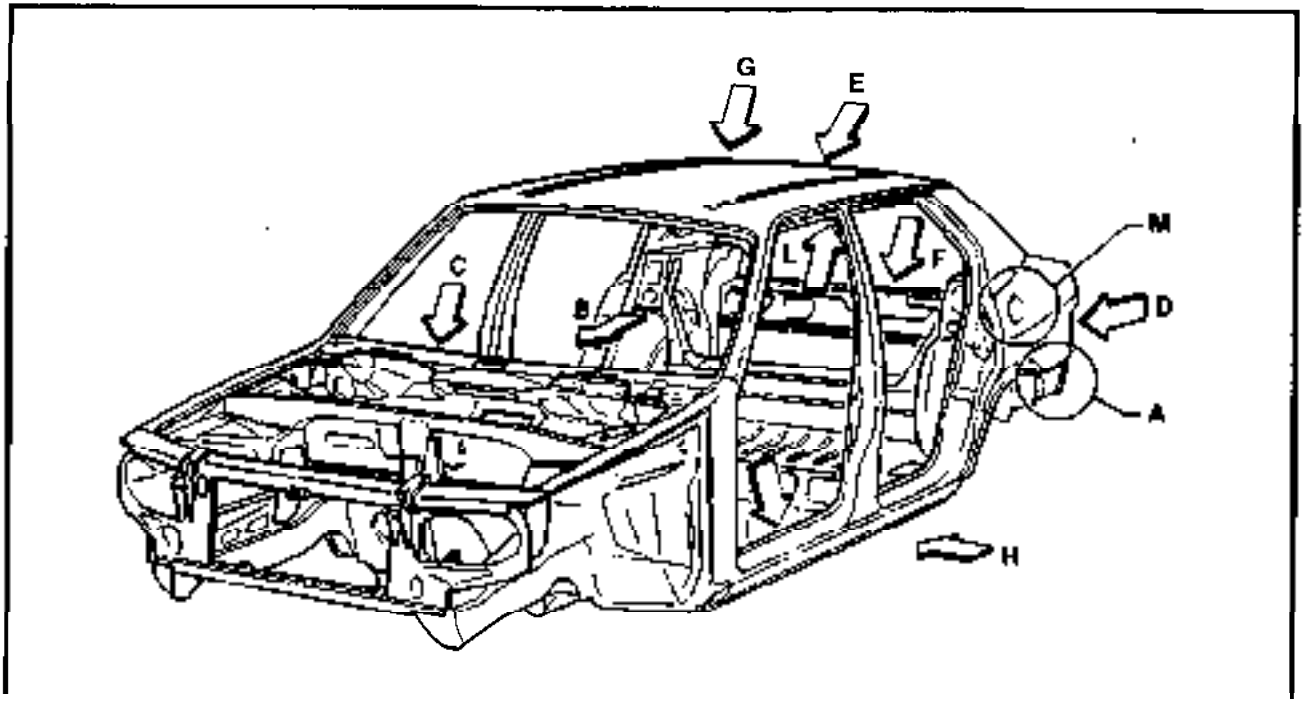

BODY - SHEET METAL PANELS

View from I

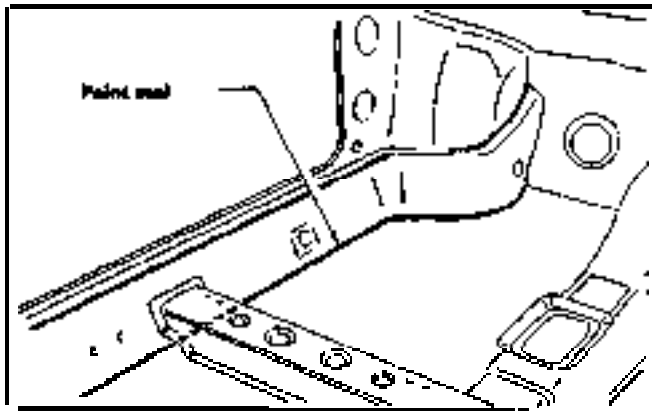

View from L

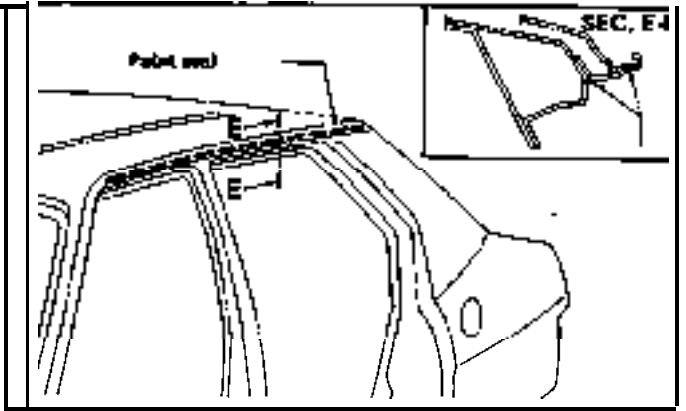

Detail M

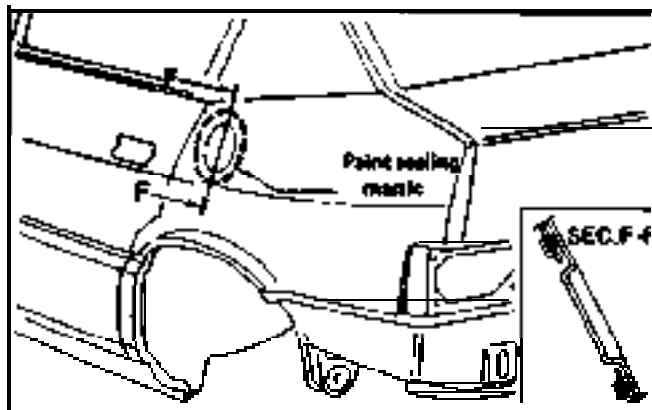

BODY ALIGNMENT

MEASUREMENT OPERATIONS

Method of measurement operation

- When a tram tracking gauge is used, adjust pointers (A) and (B) to equal lengths as shown in the following figure.
Check pointers and gauge itself in order to make sure that no clearance is present.

- When a measuring tape is used, verify there is no elongation, twisting or bending.

If, during measurement operations, tape interfere with one or more parts of car body, accurate measurement of distance and length will not be possible.

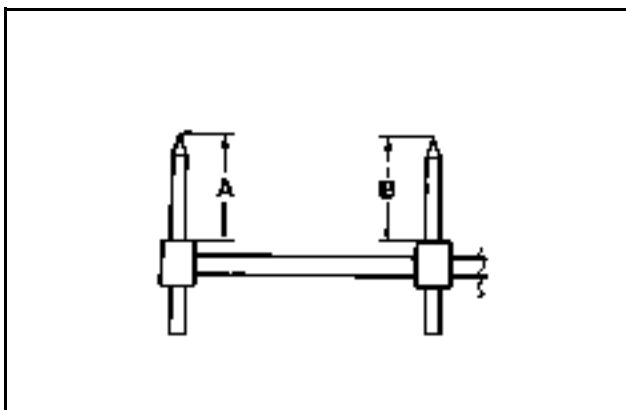

MEASUREMENT POINTS

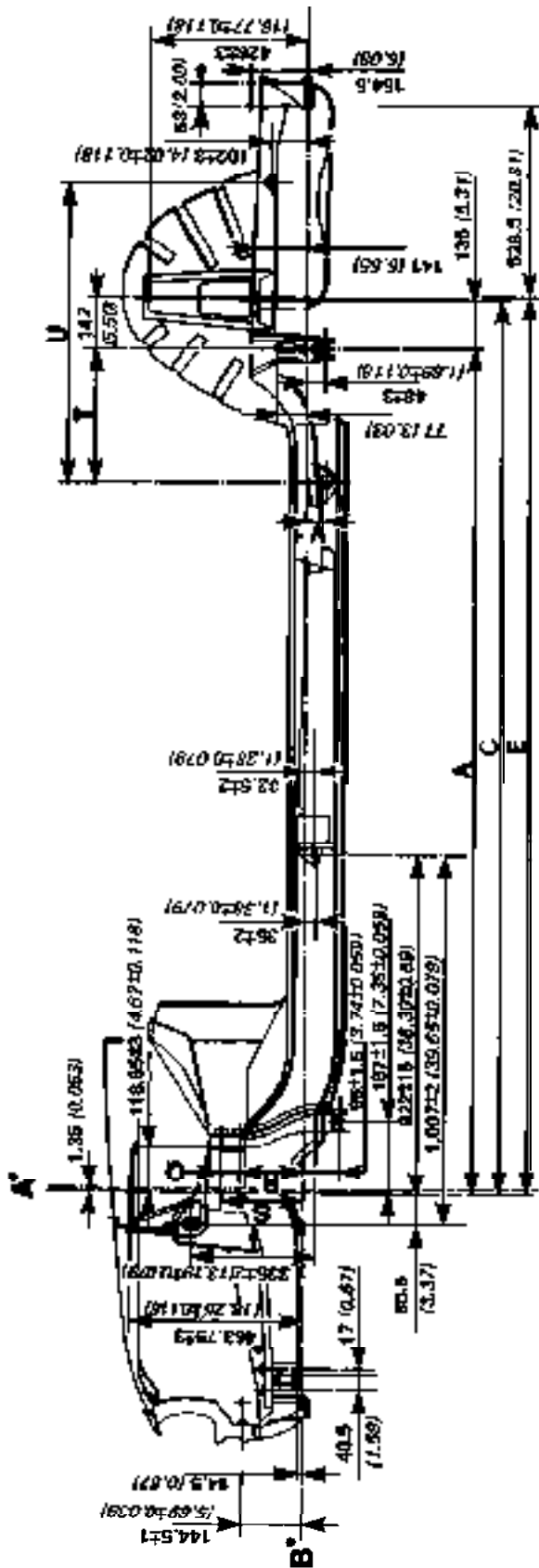

A* – Transverse reference axis

B* – Vertical reference plane

Units: mm (in)

Reference and Tolerance	A ± 1 A ± 2 (A ± 0.039) (A ± 0.079)	C ± 2 (C ± 0.079)	E ± 2 (E ± 0.079)	Q ± 0.5 (Q ± 0.018)	R +2 -3 (R + 3.079) (R - 0.118)	S ± 0 -16 +0 -0.50	T +0 -15 +D -D.50	U ± 1 (U ± 0.039)	V ± 3 (V ± 0.118)
Body Control Dimensions	2315 (91.74)	2450 (96.46)	2487 (98.73)	78 (3.07)	108 (4.26)	237 (9.33)	498.5 (19.65)	952.5 (37.50)	91.5 (3.60)

- A – From wheel middle to Panhard rod connection
- C – From wheel middle to shock absorber lower connection
- E – From wheel middle to shock absorber upper connection
- Q – Distance between holes of guide tube bracket fixing bolts
- R – From tube guide lower fixing bolt hole to vertical reference plane
- S – From guide tube upper fixing bolt hole to vertical reference plane
- T – From rear suspension front tie rod connection to Panhard rod connection
- U – From rear suspension front tie rod connection to rear suspension rear tie rod connection
- V – From front suspension reference plane to rear suspension front tie rod

BODY-SHEET METAL PANELS

2. Outer parts protection

When removing external parts (hood, back door, moldings, finishings) it is necessary to protect body surfaces with clothes, protection tape or other materials, in order not to damage or scratch vehicle body.

The scratched painted surfaces must be repaired: even a slight scratch may cause corrosion.

CAUTIONS DURING REPLACEMENT OPERATIONS

Use genuine spare parts.

It is recommended always to use genuine spare parts. This allows perfect repair and restoration of vehicle original functioning.

CAUTIONS DURING WELDING OPERATIONS

Spot welding

1. Spot welder

Before starting welding operations, carry out the following checks in order to obtain welding sufficient strength:

(1) Welder arm adjustment

- Keep the arm as short as possible in order to obtain welding maximum pressure.
- Tighten arm and tips securely so as they do not get loose during soldering operations.

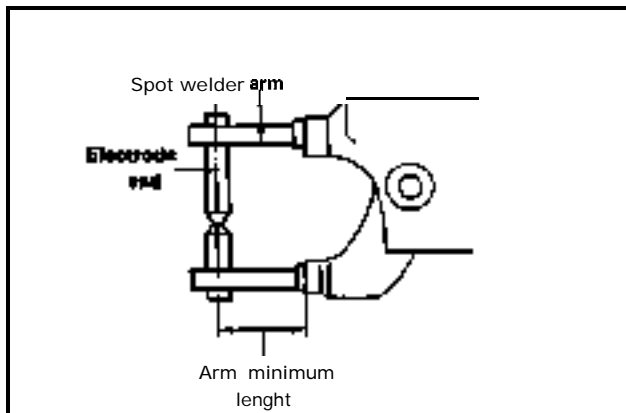

(2) Electrode alignment

Align ends of upper and lower electrodes. A misalignment of electrodes generates insufficient pressure of soldering points and, as consequence, an insufficient strength of points themselves.

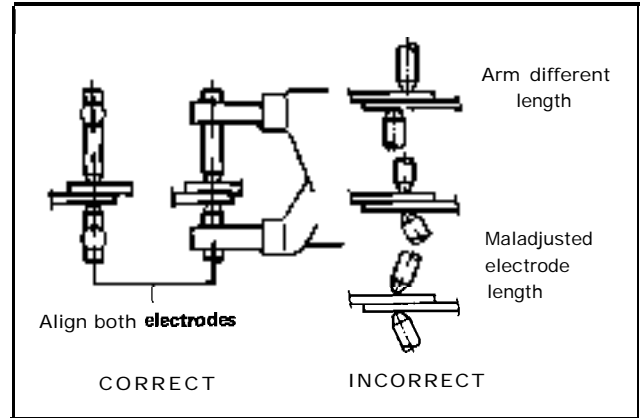

(3) Electrode end diameter

It is necessary to carefully verify diameter of electrode ends in order to obtain the required welding strength. Before starting working, make sure that end diameter (D) has a value proportional to sheet thickness.

Remove burnt and foreign matters from electrode ends.

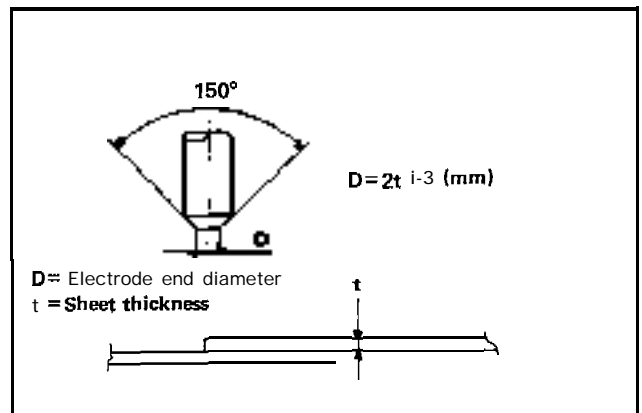

2. Condition and preparation of panels to be soldered

If the surface of the parts to be welded presents gap, paint film, rust or dust, this prevents welding current flow, thus reducing soldering area and, as consequence, strength of welding spot.

Before starting welding, verify conditions of the parts to be welded, carrying out proper corrections.

(1) Clearance between the parts to be welded.

Presence of any clearance between surfaces to be welded, causes reduction of current flow, The welding thus obtained, results to be insufficient and poor in strength, Before carrying out soldering, match the surfaces and, when necessary, tighten them by means of a clamp.

BODY -SHEET METAL PANELS

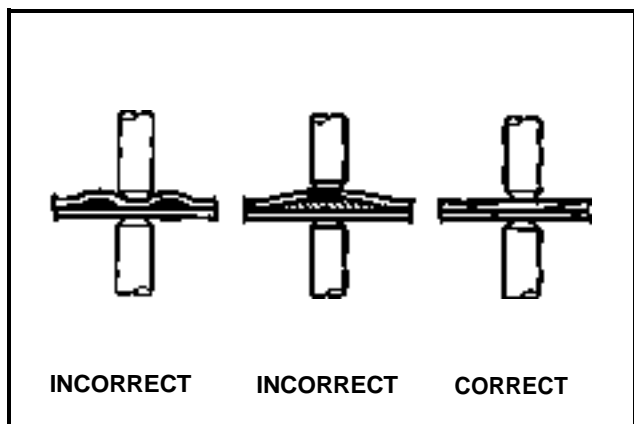

(2) Electrode installment.
Operate such as sheet forms a tight angle with electrodes. If not so, current flow will be low and the obtained welding strength insufficient.

(3) Welding of three or more overlapped sheets. In the areas where three or more sheets are overlapped, spot welding must be repeated.

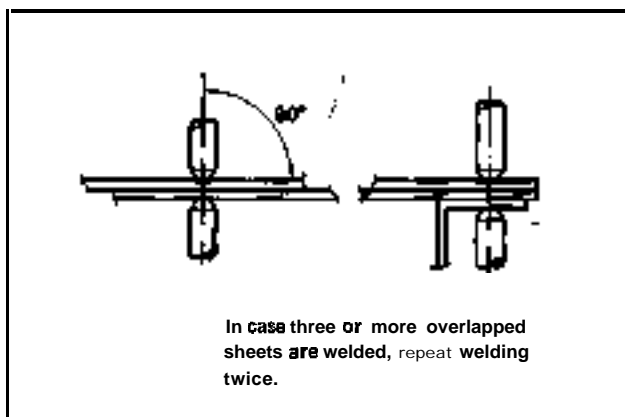

(2) Welding of metal surfaces.
Prepare the surfaces to be welded, removing all impurities and foreign matters (paint, dust, rust) in order to obtain perfect welding.

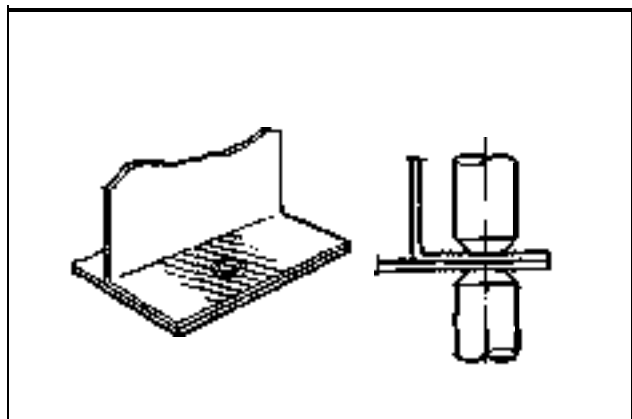

(4) Number of spot welding points.
Generally, efficiency of spot welders available in the Repair Shop is lower than efficiency of spot welders used at the Factory. As consequence, the number of spot welding points performed at the Service Shop should be increased by 20 - 30% with respect to weldings performed at the Factory.

(5) Minimum welding pitch.
The minimum welding pitch is function of thickness of sheet to be welded. Generally, the values provided in the following table, should be observed.

(3) Anti-corrosion procedure applicable to all metal surfaces.
Coat the surface to be welded high conductivity anti-corrosion agent. It must be applied to end of surface to be welded, also.

Thickness (t) mm (in)	Minimum pitch (l) mm (in)
0.6 (0.024)	10 (0.39) or more
0.8 (0.031)	12 (0.47) or more
1.0 (0.039)	18 (0.71) or more
1.2 (0.047)	20 (0.79) or more
1.6 (0.063)	27 (1.06) or more
1.8 (0.071)	31 (1.22) or more

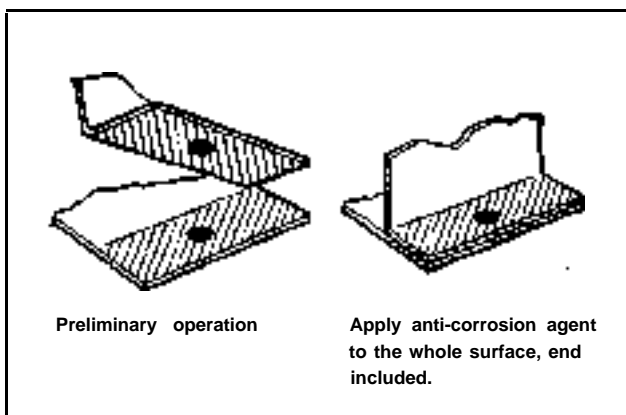

3. Cautions during spot welding

(1) Spot welding selection

Use the direct welding method (for the parts this method can not be applied to, use the MIG welding method).

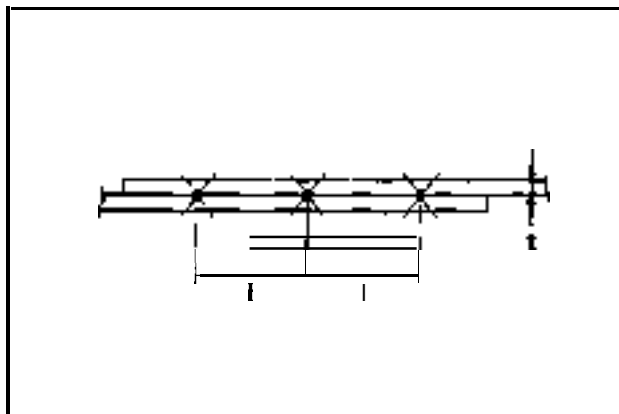

BODY – SHEET METAL PANELS

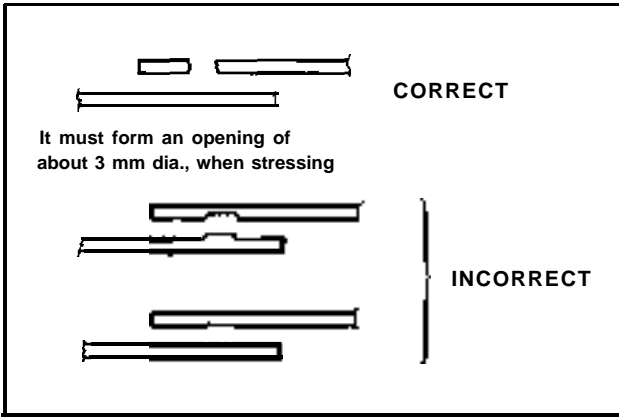

(2) Test to be carried out after welding, by means of chisel and hammer.

- Insert tip of a chisel between the welded sheets and slightly tap on chisel until, between sheets, it is obtained a 3 to 4 mm clearance (0.12 to 0.16 in); if, on the welded part, no strain is present, test result is then positive.
- If sheets thickness is not equal, clearance between sheets must be limited to 1.5 to 2 (0.059 to 0.079 in).
Take into account that the above value is only a reference one.
- The mentioned clearance changes according to position of welding spots, flange length, welding inclination and other factors.
Do never exceed this limits in order not to cause detachment of welding points.
- After test, make sure that the strained part is repaired.

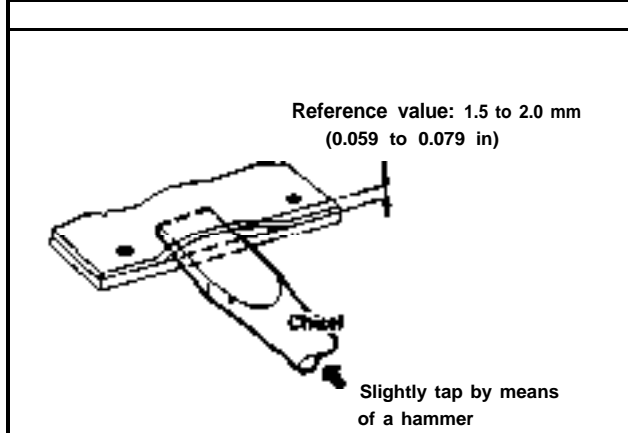
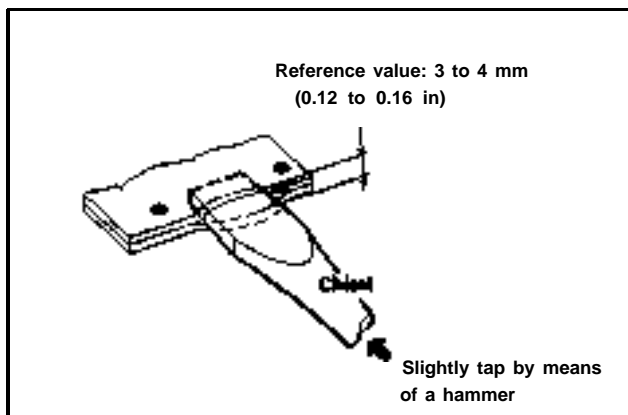

MIG welding

1. Conditions of panel to be welded.
By means of belt sander or wire brush, remove any foreign matter from surface.
Paint films, rust or oils present on sheet surface, causes decrease of welding strength, thus generating blow holes.

2. Cautions during welding operations.
- (1) Plug welding (of pre established holes)
- a) Make a hole, having 5 to 6 mm diameter (0.20 to 0.24 in) on one of the two sheets to be welded, then match the two sheets and clamp them.
 - b) Position the torch at right angle with respect to sheet, then fill metal into the hole.
Each time welding is stopped, on the surface an oxide film generates which causes blow holes. If this occurs, remove oxide by means of a wire brush.
 - c) Make sure that welding between upper and lower sheet is perfect.

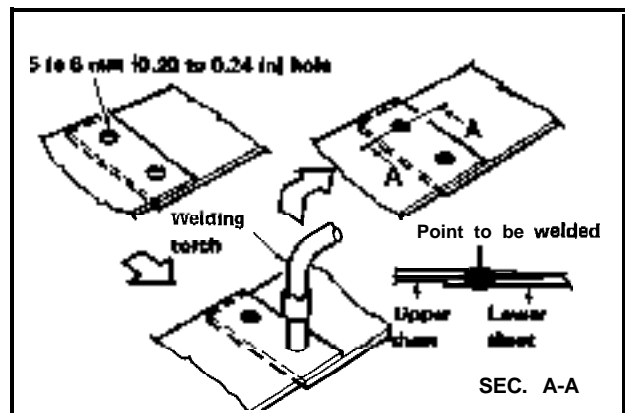
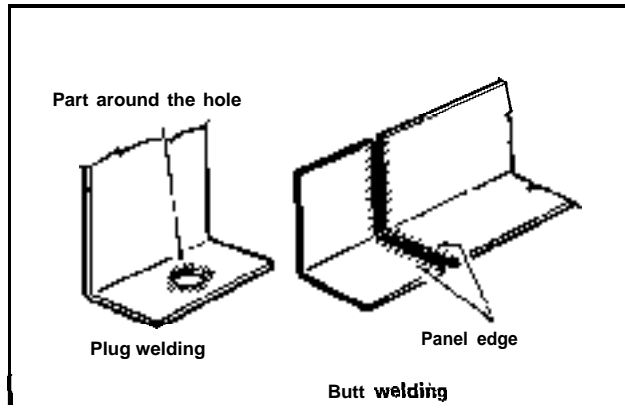

- (2) Butt welding.
- a) By means of intermittent weld, tack the two surfaces to be welded in order to prevent strains and align the two surfaces, then, fill in the spaces by placing small welding beads.

REPLACEMENT OPERATIONS

HOW TO READ THIS CHAPTER

The formulation of the present part of the manual is uniform for all the replacement operations. For its structure, refer to the following example.

(I) HOODLEDGE PANEL WITH RADIATOR CORE SUPPORT REMOVED
 Carry out replacement after Radiator Core Support has been removed.

(II) Service joints

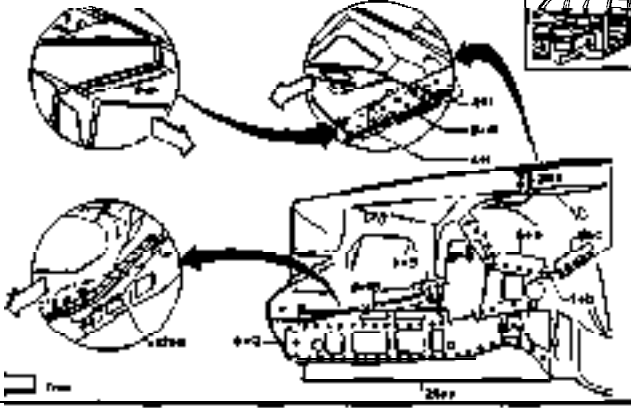

(IV) REMINDER WHEN REMOVING

- By means of air saw, cut according to lines A, B, C and, by means of air chisel, cut according to line D.

(III) PARTS TO BE WELDED

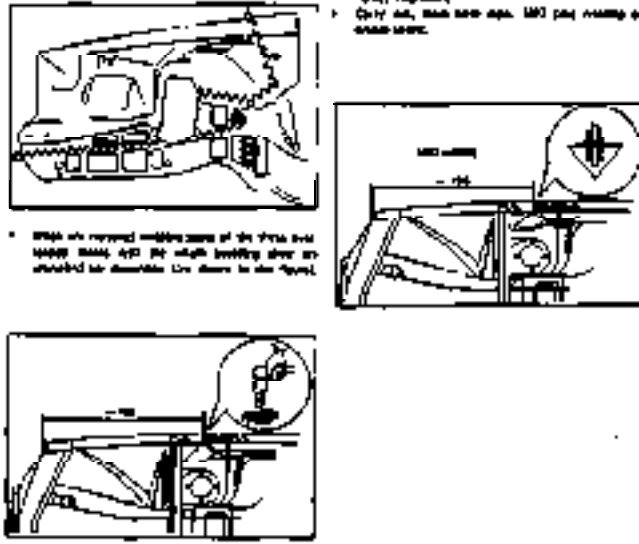

Upper front edge...
 Lower front edge...
 1. Spot welding...
 2. Spot welding...
 3. Spot welding...
 4. Spot welding...
 5. Spot welding...
 6. Spot welding...
 7. Spot welding...

In detail:

(I) "HOODLEDGE. PANEL WITH RADIATOR CORE SUPPORT REMOVED"

In the title it is indicated the element to be removed (hoodledge) specifying, if required, the operative condition (in this case, radiator on core support removed). If the element is not in the required conditions, it is necessary, to execute preliminary removal of the other components; in the present case, it is necessary to remove the radiator core support, referring to the specific replacement procedures.

The parts represented by chain line, set in evidence the components which must result to be removed or for which it is required the preliminary removal, accordingly to step (I).

(II) "SERVICE JOINT"

Any information concerning the welding operations to be carried out is shown in the figure indicating the welding method and the spot numbers, together with accurate location of spots on the elements to be joined.

(III) PARTS TO BE WELDED

A list is provided relevant to the components which are to be welded using the methods indicated in step (II).

(IV) REMINDER WHEN REMOVING/INSTALLING

Indication is provided, relevant to the main operations to be carried out, with special care in identification of the areas concerned in the cut operations, selection of the equipments to be used and definition of welding methods to be adopted.

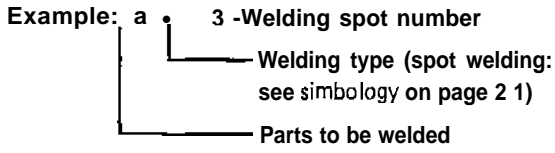

CUTTING AND WELDING/BRAZING OPERATIONS

The symbology used for the cutting and welding/brazing operations is shown in the following figures.

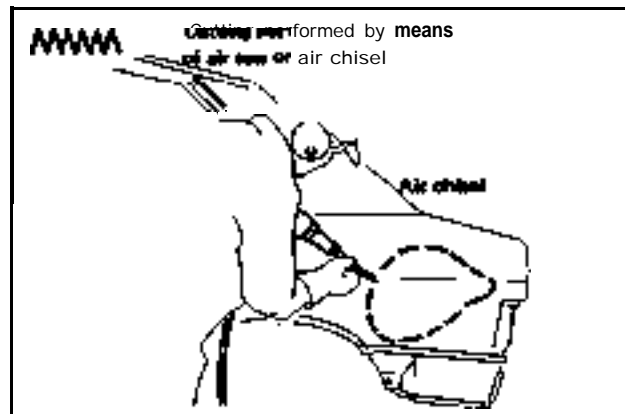
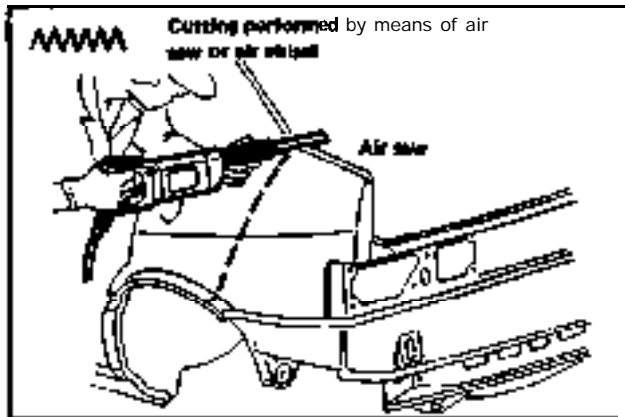

Spotwelding

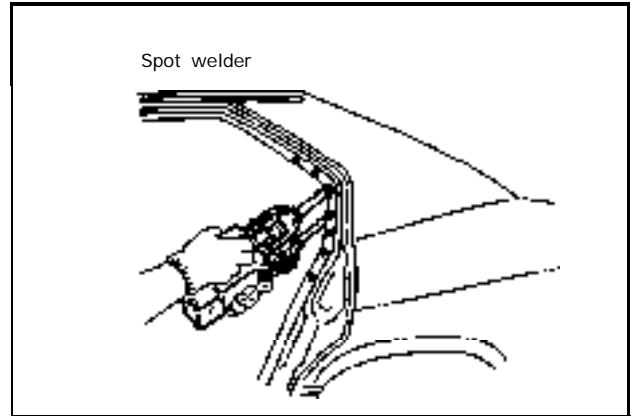
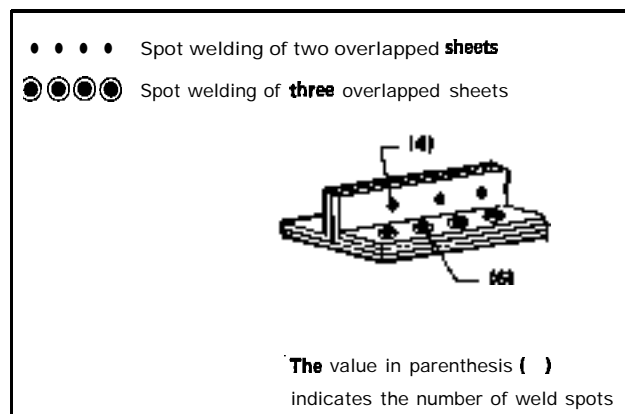

CO₂ arc welding

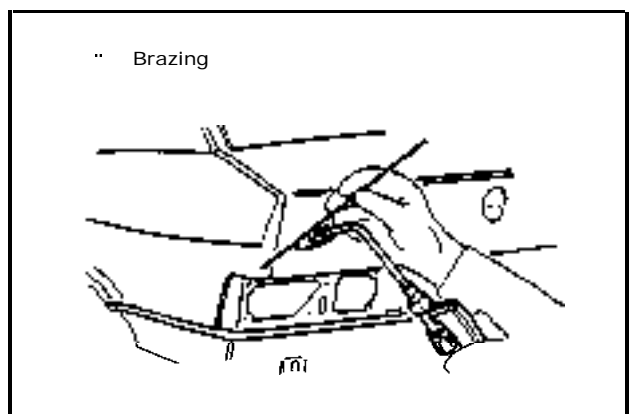
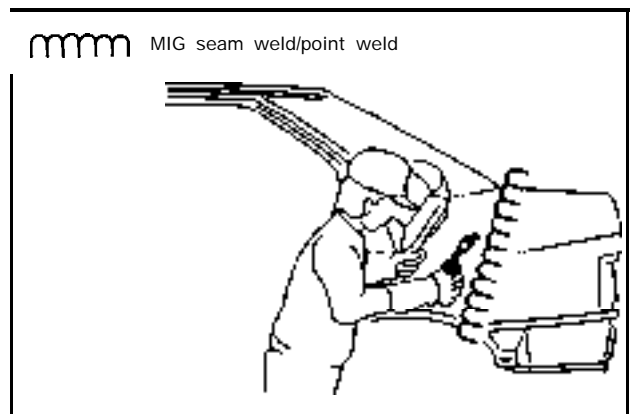
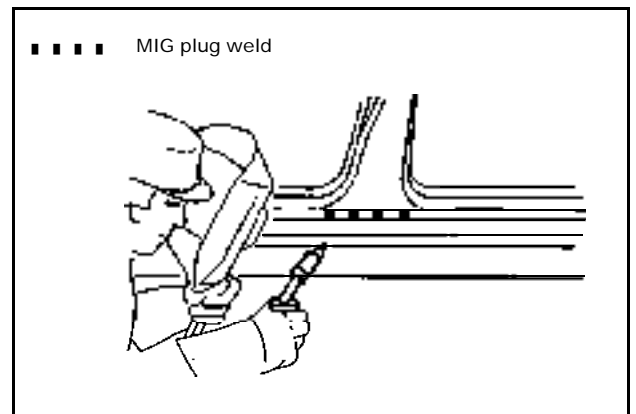

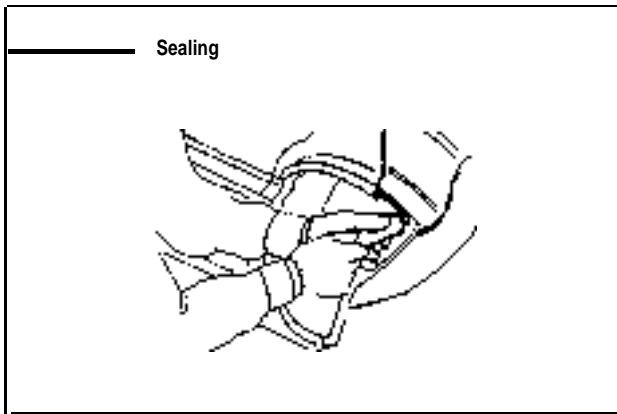
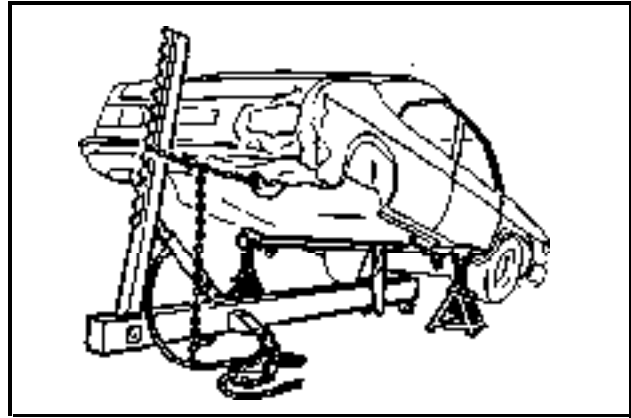
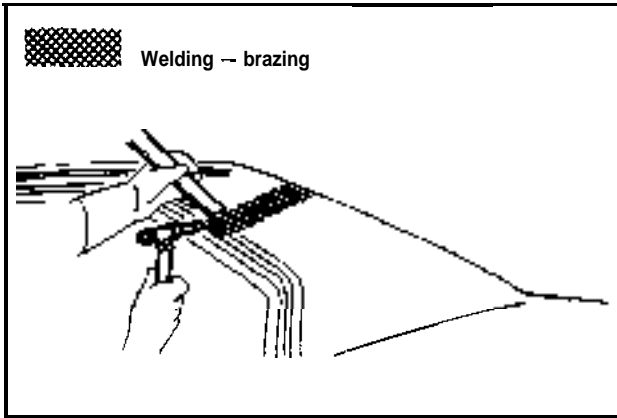

(3) Cut-off damaged parts.

Tools required:

- Air saw
- Air chisel

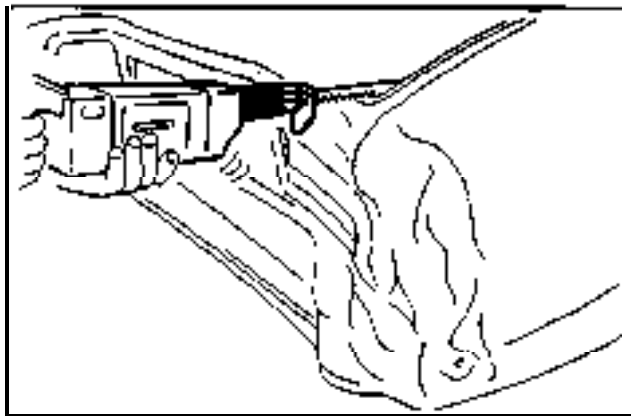

REMOVAL AND INSTALLATION PROCEDURES

COMPONENT REMOVAL

(1) Make sure that all the damaged parts have been detected, by measuring the installation main dimensions. Refer to "Body Alignment" drawing.

Tools required:

- Centering gauge
- Tracking gauge
- Convex rule
- Rack-and-lever jack or car lift

(2) With a body-frame repair system, carry out draw operations, depending on deformation condition. Reuse of the reclaimable parts must be performed in accordance with the figures contained in "Body Alignment".

Caution during operation:

- Carefully secure drawing chains to body and equipment, so as to prevent accidental release during operation execution.
- Apply draw stress in the direction opposite to collision.

(4) If welding spots are not visible, remove paint by means of rotary wire brush.

Tools required:

- Rotary wire brush

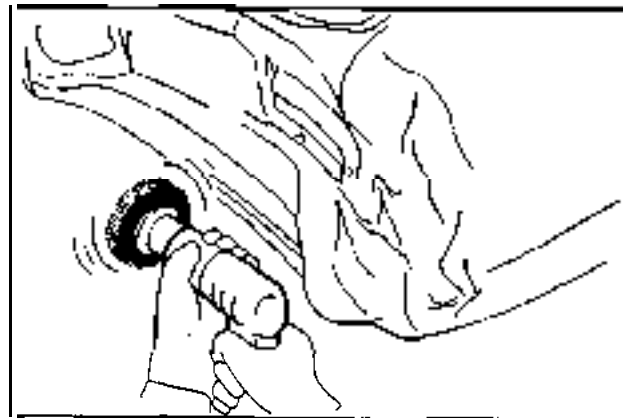

(5) Punch all the welding spots in order to make centering of a drill.

Tools required:

- Hammer
- Center punch

BODY -SHEET METAL PANELS

Caution during operation

- Punch deeply in the center of each, welding spot. A non-centered punch does not allow complete cut of nugget. Besides, a shallow marked hole location does not allow a reliable drive of drill.
- As a rule, punching must be executed from sides of the components that are to be removed.

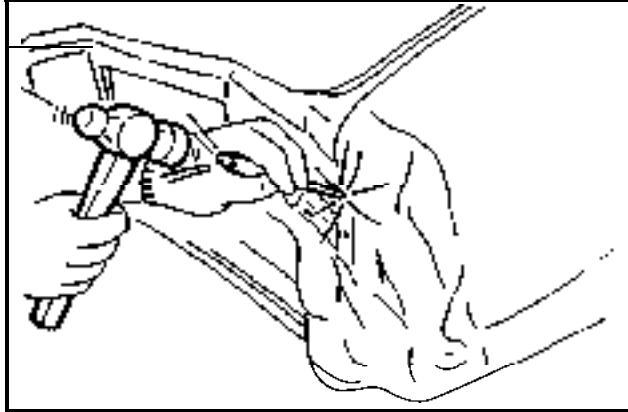

(6) Remove welding spots by means of a spot cutter or an air drill.

Tools required:

- Spot cutter
- Air drill

Caution during operation:

- Use a drill speed of about 1000 r.p.m. in order to obtain the best results.

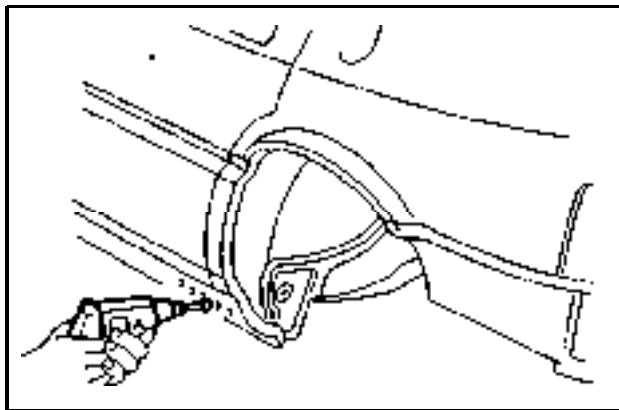

Cautions during operation:

- Take care not to drill mating parts. In case holes have been made, plug them making use of gas or MIG plug welding. Presence of holes, decreases strength of the concerned component, besides, it may generate water leakage.
- When, for new components, are used holes already drilled in welded parts (just as per those of the spot welding) make use of a drilling machine having small diameter drill (below 8 mm (0.31.in)) and complete welding as soon as possible.

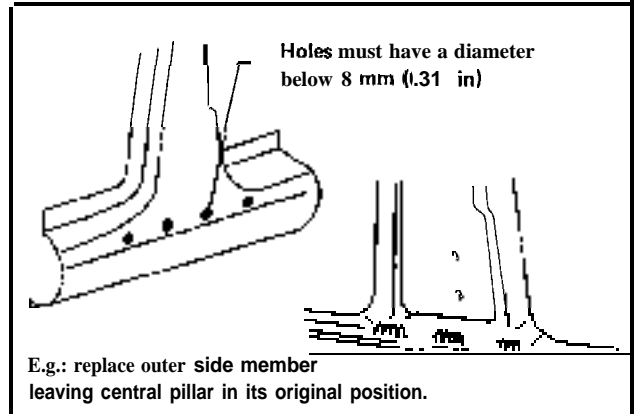

(7) By means of a chisel remove the remaining spot welding parts.

Tools required:

- Chisel
- Hammer

PREPARATION FOR MATING PARTS INSTALLATION

(1) By means of a sander, grind sheet in correspondence with welding spots.

Tools required:

- Air sander
- Disc sander

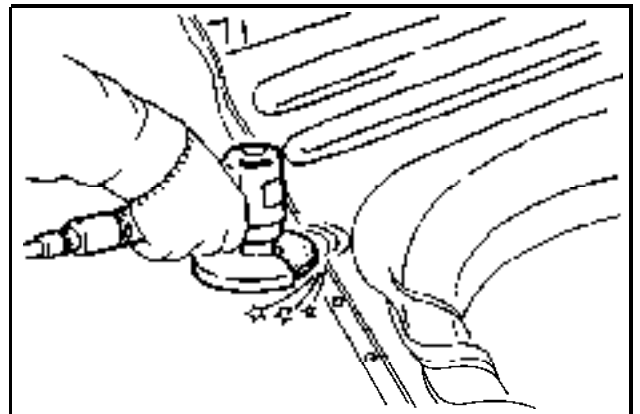

Cautions when grinding

- Take care not to cut much on base metal: this may generate decrease of sheet thickness and, then, welding strength.

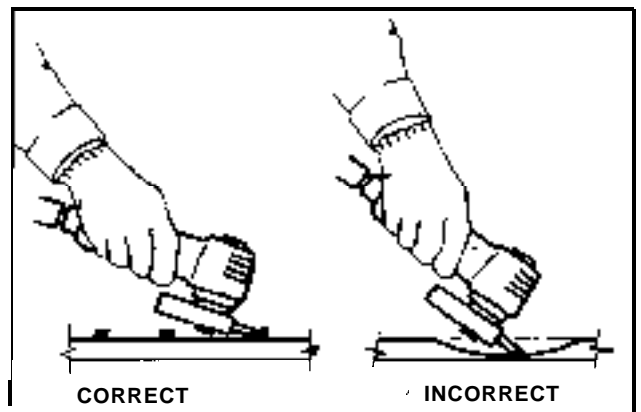

BODY -SHEET METAL PANELS

- Carefully remove iron powder from the surfaces which have been grinded and from surrounding areas. Presence of iron powder, causes decrease of welding efficacy and can also generate corrosion,

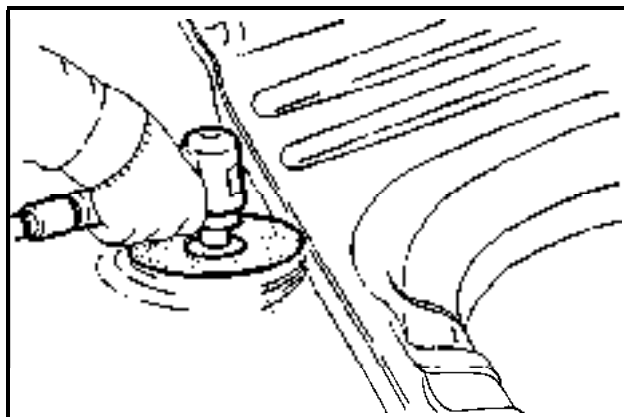
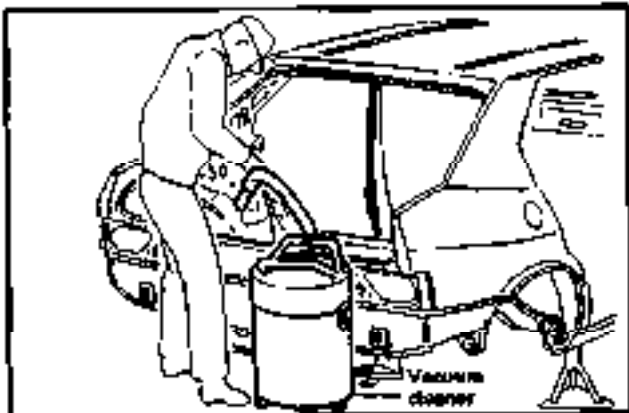

- (4) Apply primer to edges of new components and of body panels which are to be welded.

- (2) By means of a hammer and dolly correct deformed areas.

Tools required:

- Hammer
- Dolly

Cautions during operation:

- Check against presence of even the smallest deformations, in particular, in the inner panels where they are hard to be found. Infact, if they are not removed, they can cause a strength decrease due to stress concentration.

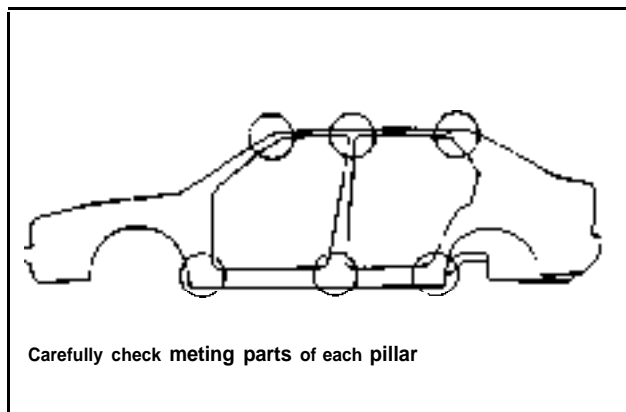
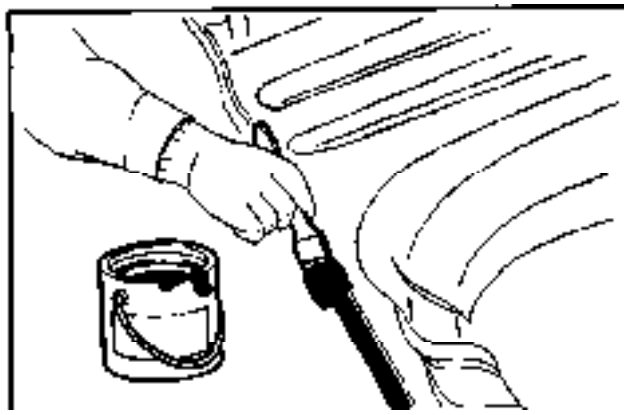

Carefully check meting parts of each pillar

- (3) Remove paint from welding edges.

Tools required:

- Belt sander
- Disc sander

Before welding apply conductive antirust paint on edges of all sheet parts which are to be assembled.

Recommended paint:

Part. No. 3540-44401

SAVID: Zincovid No. 7949

SCHRAM LACK: Extrinom Punktschweifarbe

GLASURIT: Glassomax 7 F 4625 (red color) *

* To be used with catalyst

Glassomax Harter 965-7/1 in the proportion 1 :10 (part. No. 3541-20003).

Panels must be welded within 15 minutes of the paint application (air drying time of paint film).

The film thickness after drying must be 0.005 to 0.025 mm. (2 to 9.8) 10^{-4} in.

PREPARATION FOR NEW COMPONENT INSTALLATION

(1) If a partial replacement is to be carried out, it is necessary to maintain an overlapping tolerance of about 50 mm (1.97 in) during cut of non-usable sheets, in order to have a sufficient mating surface.

Tools required:

- Air saw
- Hack saw
- Tracking gauge
- Convex rule (or equivalent)

It is recommended always to use genuine spare parts. This ensures a perfect repair and restoration of vehicle functioning.

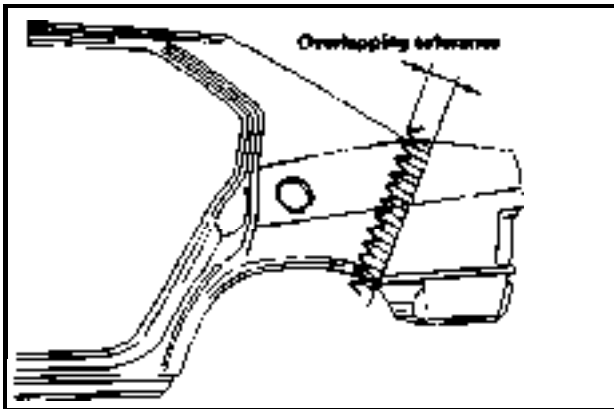

(2) MIG plug weld.

This method must be used for those areas which can not be reached by spot welder. To carry out this operation, drill in the welding spots, making holes having 5 to 6 mm. (0.20 to 0.24 in) dia.

Tools required:

- Puncher
- Air drill

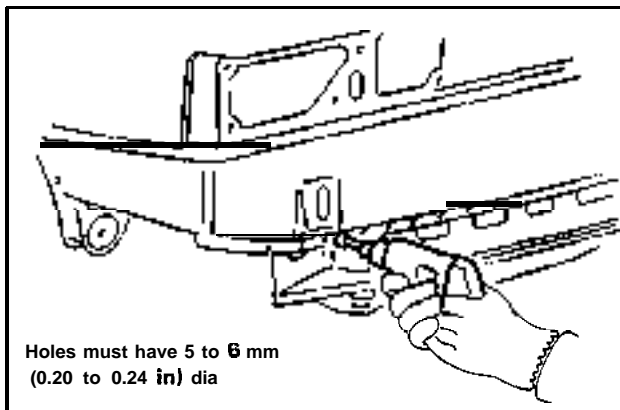

(3) Remove paint from components to be welded.

Tools required:

- Belt sander
- Disc sander

Cautions during operation:

- Remove paint from both sides of components that are to be welded, such as the surfaces to be spot welded, spot welding rims and edges of surfaces to be butt welded.

The remaining paint, prevents current flow into spot weldings, with consequent poor strength of spot. It can also generate depressions in the plug MIG welding.

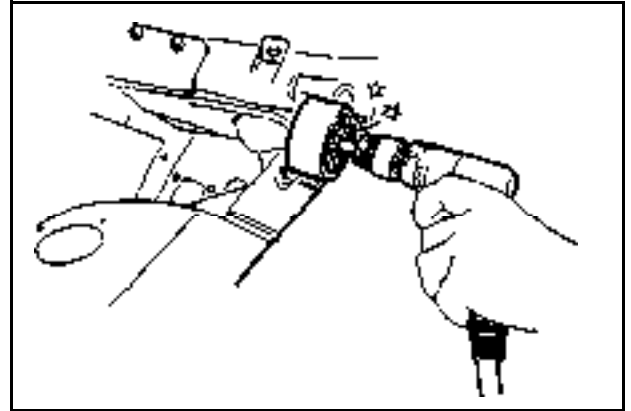

(4) Apply primer to component and body surfaces which are to be spot welded.

Tools required:

- Wire brush
- Conductive anti-rust paint

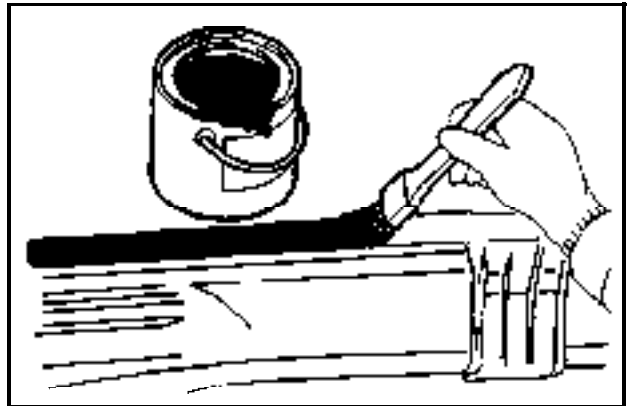

INSTALLATION

(1) New service parts temporary installation.

Tools required:

- Vise pliers
- Convex rule
- Tracking gauge (sight)
- Centering gauge
- Port power
- Jack
- Spot welder
- Mig welder

BODY – SHEET METAL PANELS

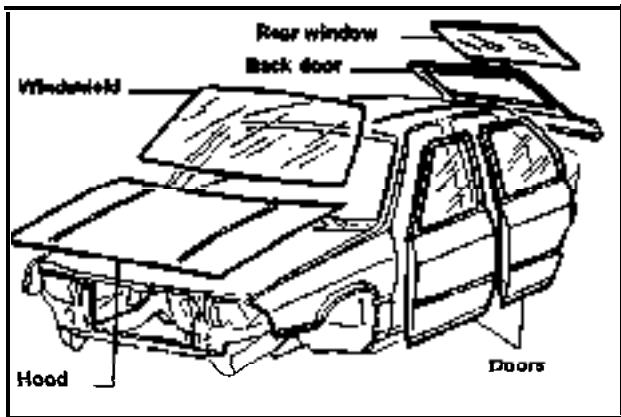

Cautions during operation:

- Position components as per figures provided in "Body Alignment". Into body compartments, install the movable parts (i.e. windscreen, doors, hood, back-door) in order to carry out check of clearances, grades and parallelism. If necessary, adjust sheets until correct alignment is obtained.
- Clamp parts to be welded by means of pliers and some welding spot.

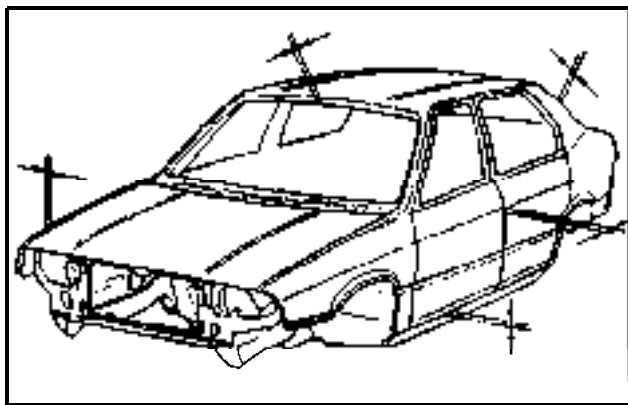

(2) Execution of the required weldings.

Carry out welding complying with specifications provided in "Cautions during Welding".

Tools required:

- Spot welder
- MIG welder
- Autogenous welder

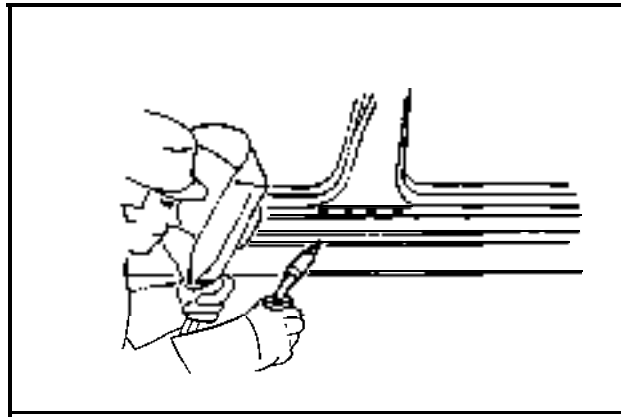
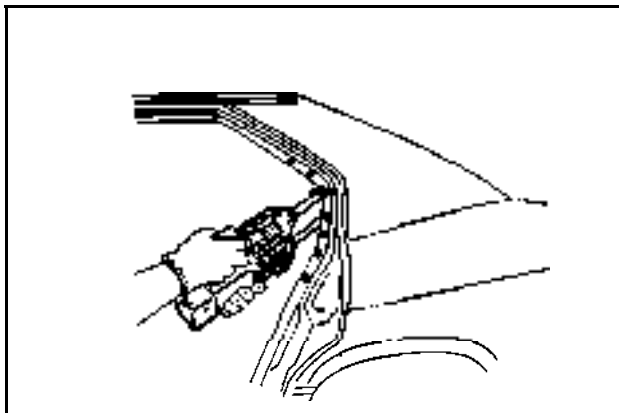

(3) Grind MIG welding by means of a sander machine.

Tools required:

- Air sander
- Disc sander

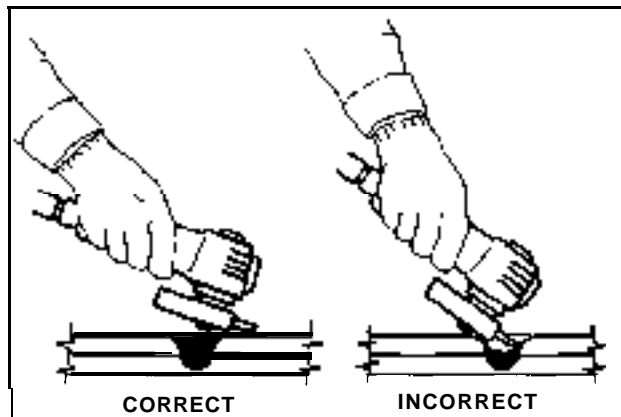

Cautions during operation:

- Take care not to grind excessively on spot weldings: it may generate decrease of sheet thickness and, consequently, welding strength.
- Remove iron powder from grinded surfaces and surrounding areas. Presence of iron powder, causes decrease of welding efficacy and can also generate corrosion.

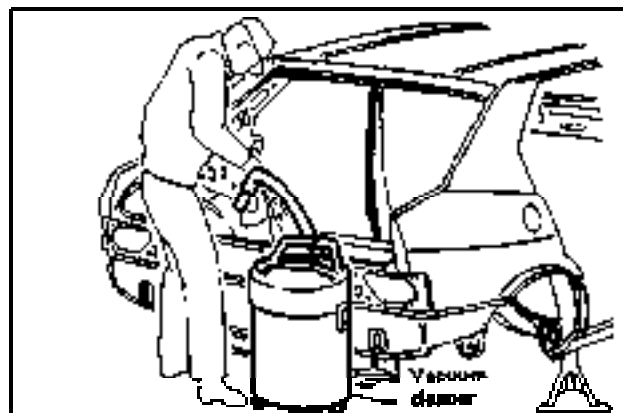

(4) After welding execution, remove clamps used for securing edges and remove possible dinging.

BODY -SHEET METAL PANELS

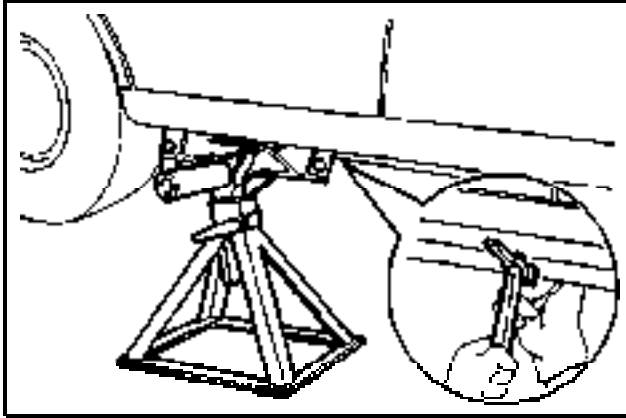

(7) For under body protection, apply a coat having 4 mm (0.16 in) thickness:

Antidrum: part. No. 3523 - 00001

Alternatives: 3M

Body Plast 8874 E

Body Schutz 8864 E

IVI Grey protective acrylic 854751

(5) Apply anti-corrosion agent to the welded components.

(6) Apply sealer to joints.

This operation must be carried out carefully in order to prevent corrosion in the welded joints.

Refer to figures provided in "Body Sealing".

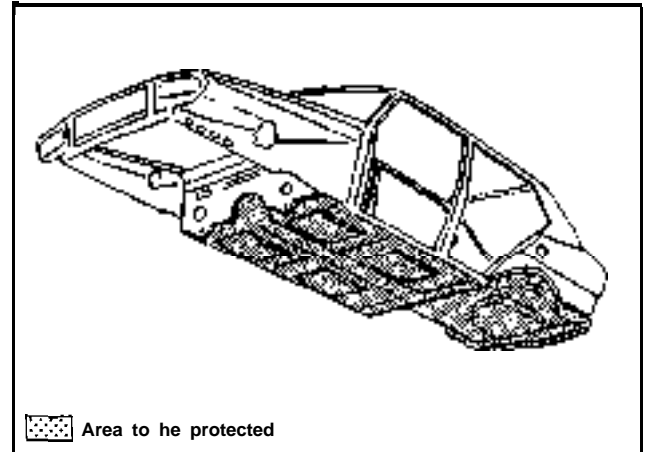
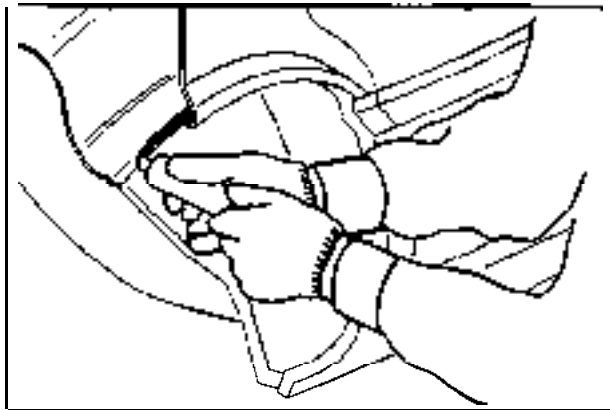

RADIATOR CORE SUPPORT

Service joints

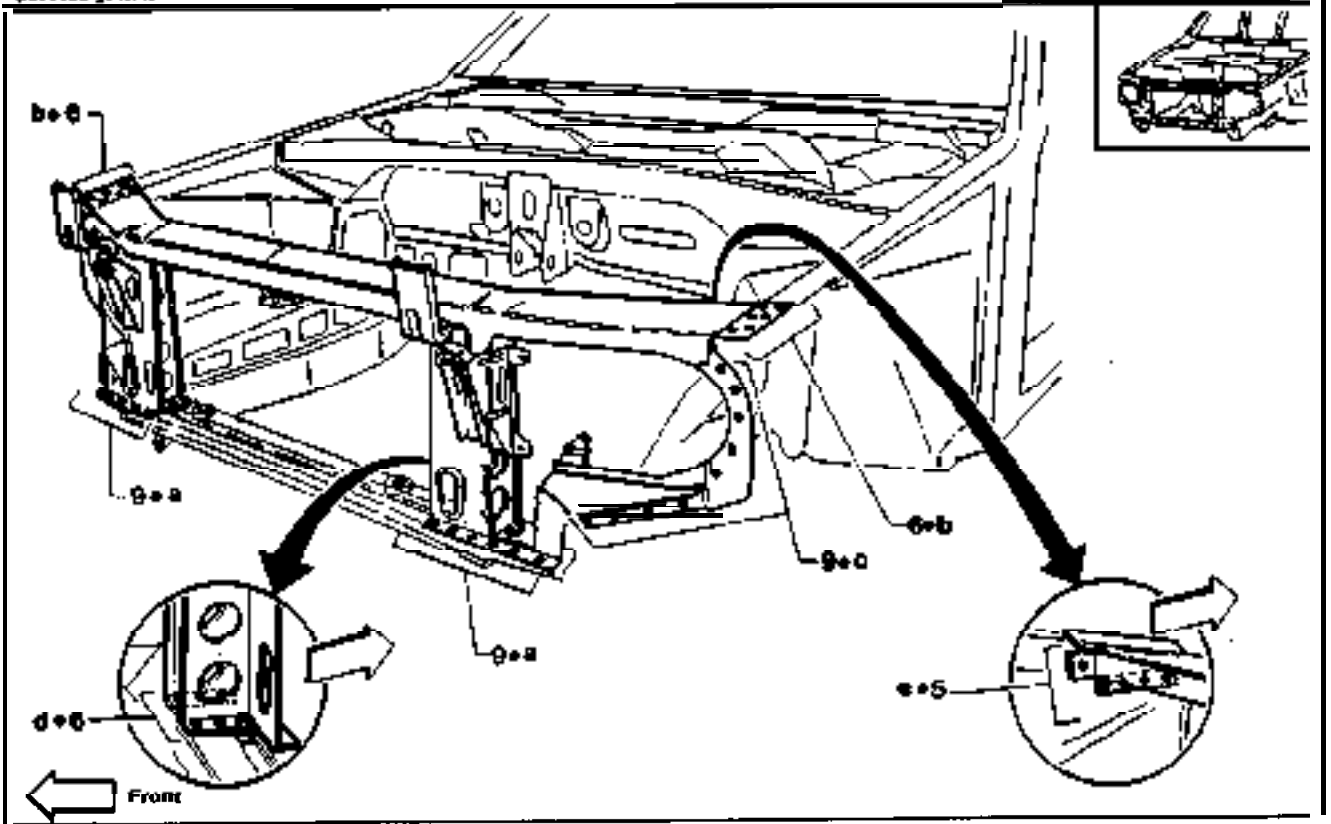

Parts to be welded

- a. Radiator core support and engine support lower cross member
- b. Radiator core support and hoodledge panel upper part
- c. Radiator core support and hoodledge panel upper part
- d. Radiator core support and engine support lower cross member
- e. Radiator core support and hoodledge panel

REMINDER WHEN REMOVING

- By means of air saw, cut along line A.

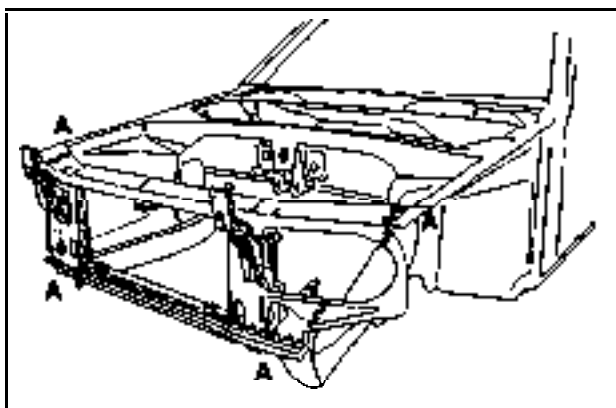

REMINDER WHEN INSTALLING

- By means of clamps, temporarily secure new radiator core support, then adjust it.

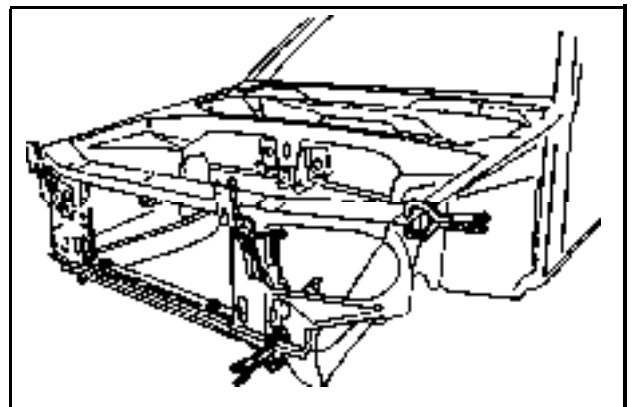

BODY – SHEET METAL PANELS

- Install parts temporarily
- Check and adjust clearances, grades and parallelisms.

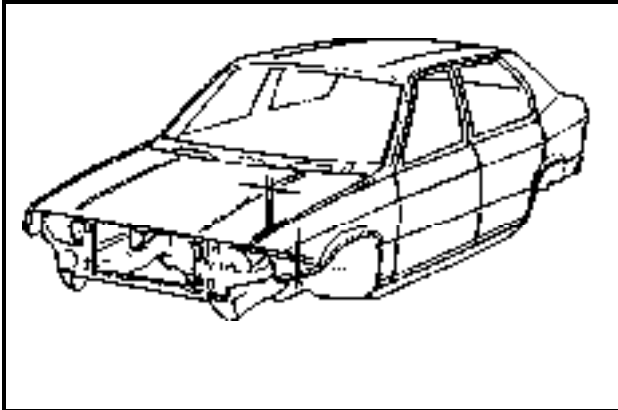

HOODLEDGE PANEL WITH RADIATOR CORE SUPPORT REMOVED

Carry out replacement after Radiator Core Support has been removed.

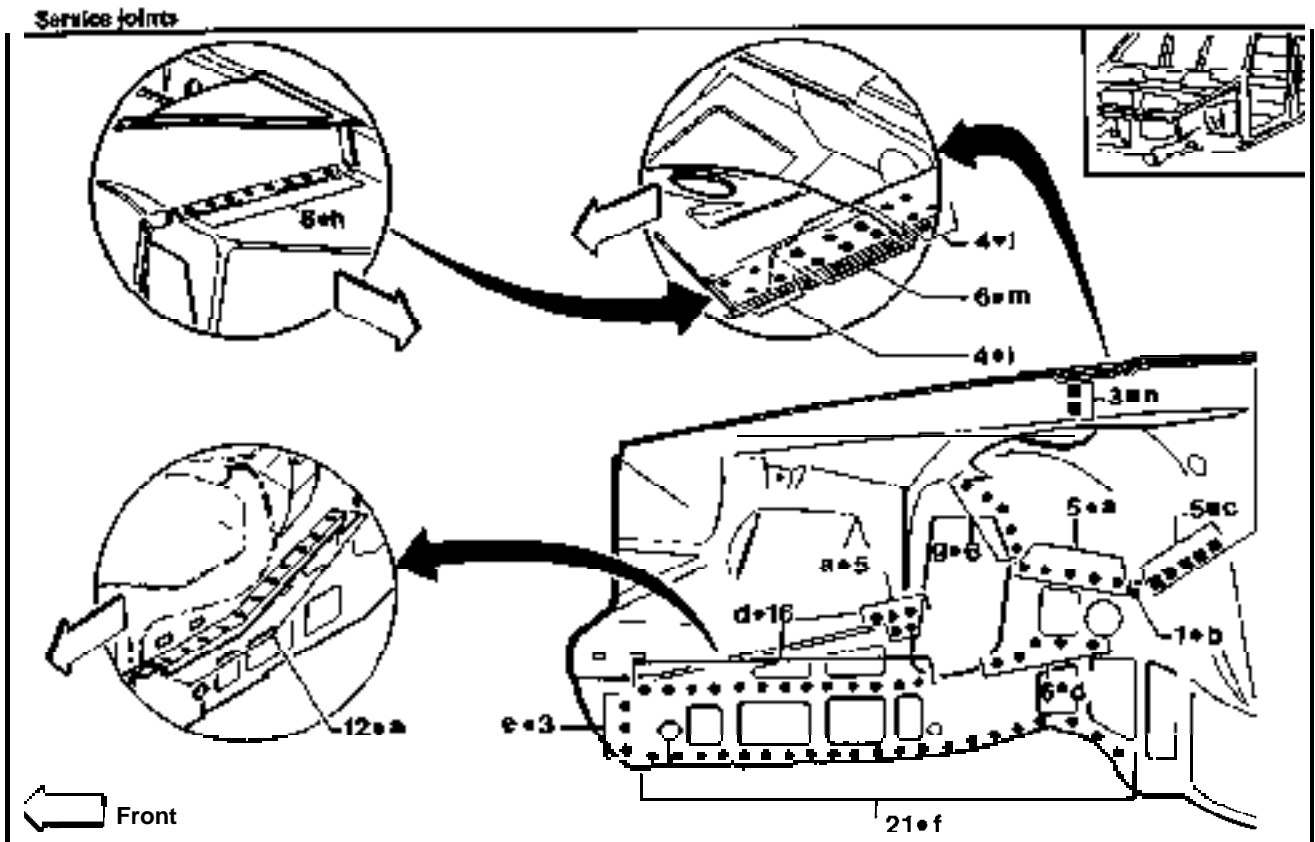

Parts to be welded

- a. Upper hoodledge assembly and lower hoodledge
- b. Lower hoodledge assembly and dashboard lower sheet
- c. Upper hoodledge assembly and dashboard lower sheet
- d. Lower hoodledge assembly and side member
- e. Lower hoodledge assembly and side member
- f. Lower hoodledge assembly and front side member
- g. Upper hoodledge assembly and engine upper cross member
- h. Upper hoodledge assembly and engine upper cross member
- i. Hoodledge assembly and engine upper cross member (spring seat cap reinforcement)
- l. Hoodledge assembly and hoodledge side reinforcement
- m. Hoodledge assembly, hoodledge side reinforcement and engine upper cross member
- n. Hoodledge assembly, hoodledge side reinforcement and engine upper cross member

REMINDER WHEN REMOVING

- By means of air saw, cut according to lines A, B, D and, by means of air chisel, cut according to line C.

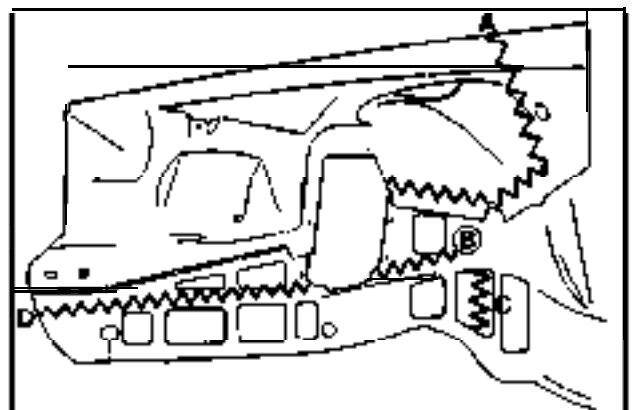

- When are removed welding spots of the three overlapped sheets drill the whole (welding spots are identified by dimension line shown in the figure).

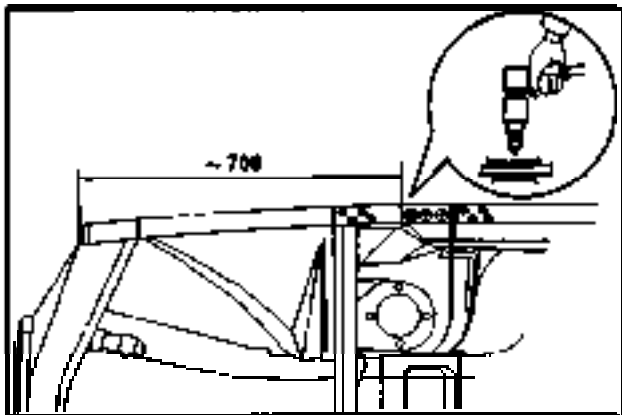

R E M I N D E R W H E N I N S T A L L I N G

- Install together radiator core support and hoodledge panel; then verify alignment dimensions concerning hoodledge panel. Refer to drawings provided in "Body Alignment".
- Carry out, from both sides, MIG plug welding of drilled sheets.

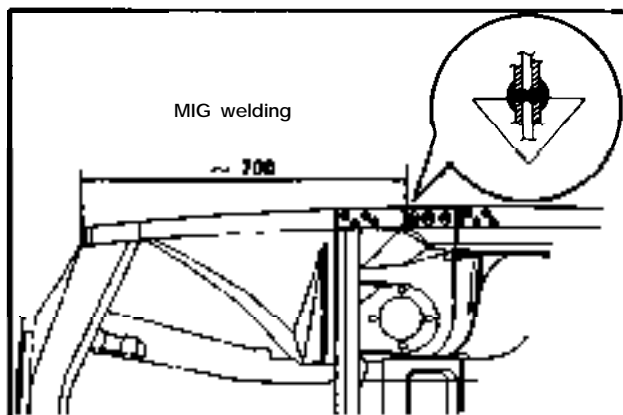

HOODLEDGE PANEL WITH RADIATOR CORE SUPPORT REMOVED (Partial Replacement)

Carry out partial replacement after Radiator Core Support has been removed.

Service joints

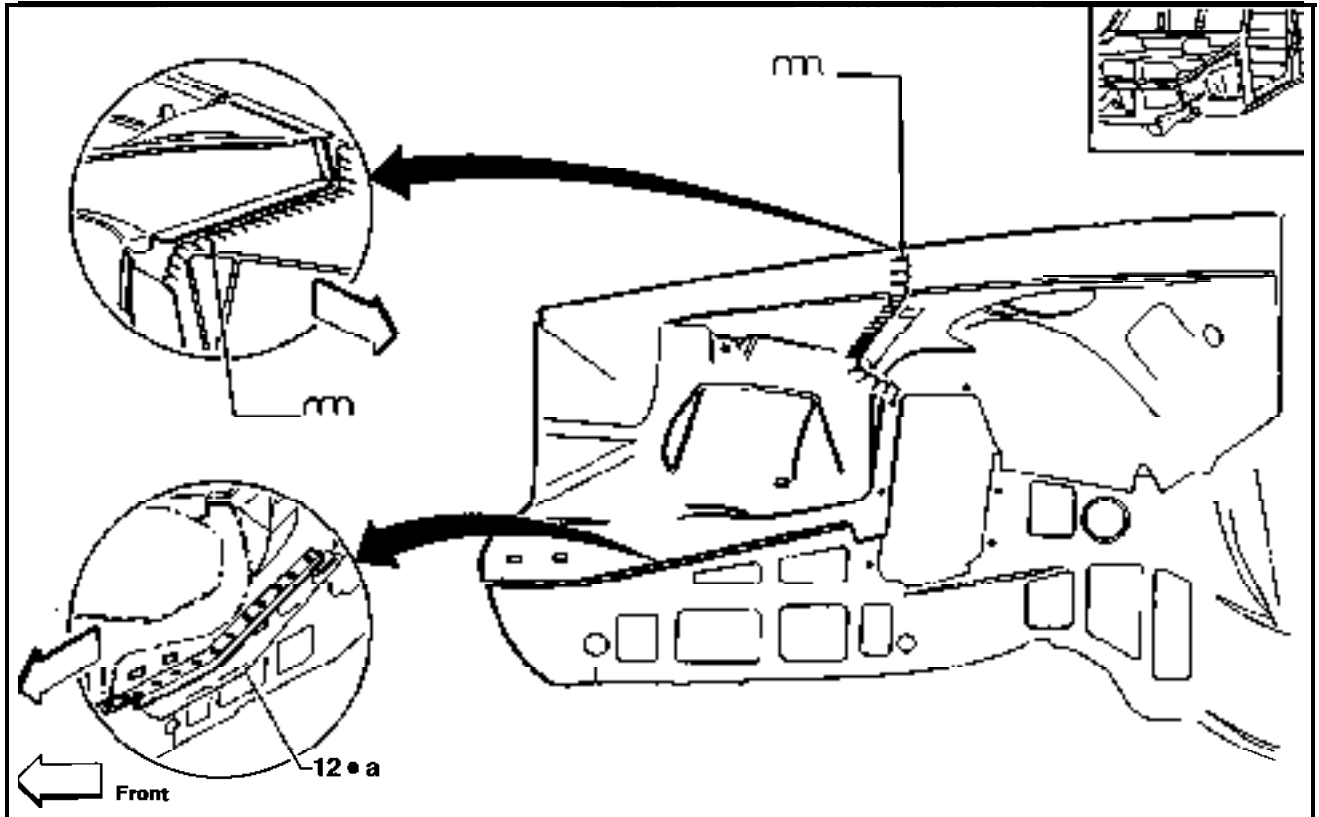

Parts to be welded

a. Upper part hoodledge and lower part hoodledge

REMINDER WHEN REMOVING

- By means of air saw, cut according to lines A and B.

REMINDER WHEN INSTALLING

Precaution when cutting the spare half hoodledge panel

- Cut spare half hoodledge panel aligned with non-replaced panel part.

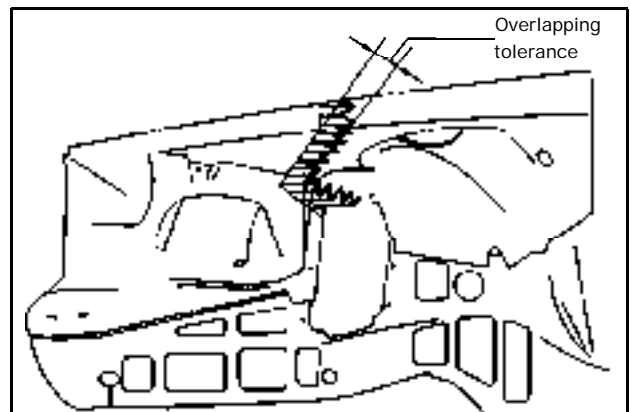
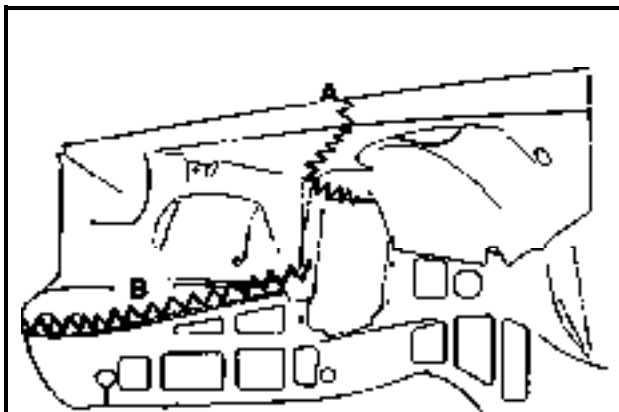

BODY -SHEET METAL PANELS

Dimension check and fender temporary installation

- Install together radiator core support, half hood ledge panel and body.
- Check alignment dimensions referring to drawings provided in "Body Alignment".

FRONT SIDE MEMBER WITH HOODLEDGE PANEL REMOVED

Carry out replacement after Hoodledge Panel has been removed.

Service joints

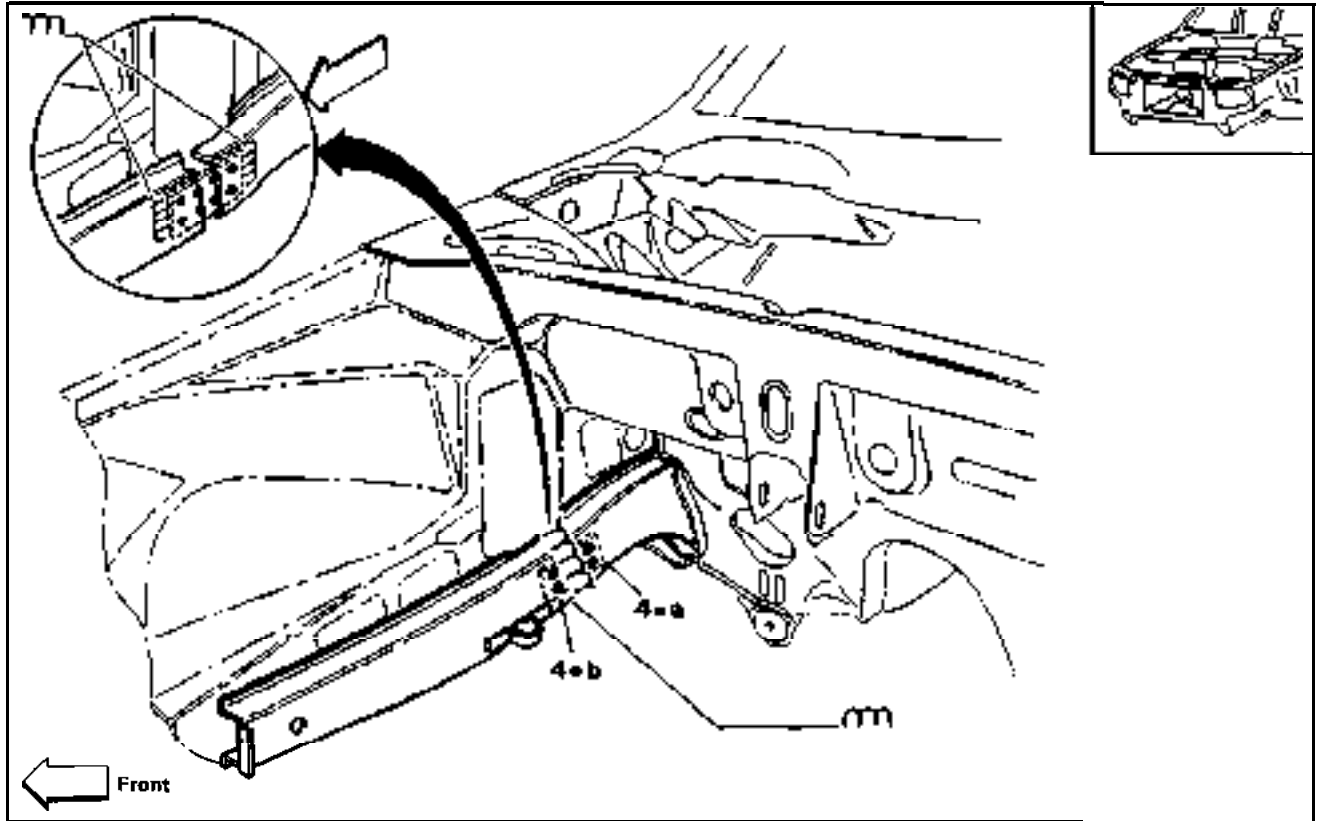

Parts to be welded

- a. Plate and replaced side member
- b. Plate and present side member

REMINDER WHEN REMOVING

- By means of air saw, cut according to line A in figure, in correspondence with the hole located on side member.

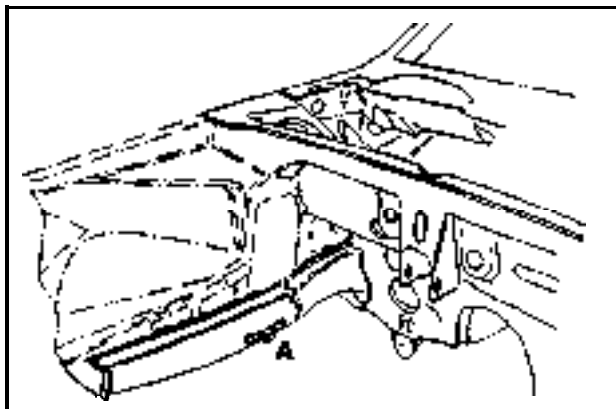

REMINDER WHEN INSTALLING

Precaution when cutting spare side member.

- Cut spare side member aligned with non-replaced side member part.

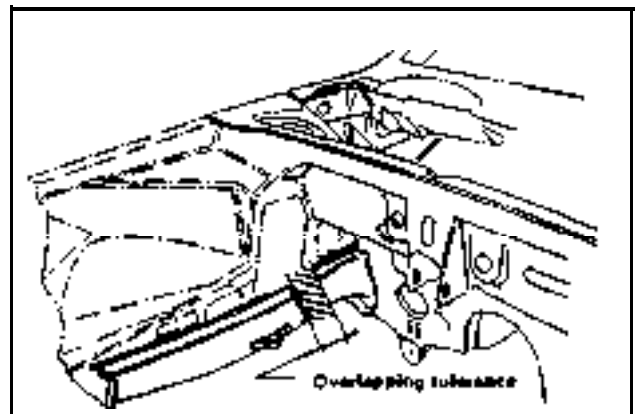

CENTRAL PILLAR

Service joints

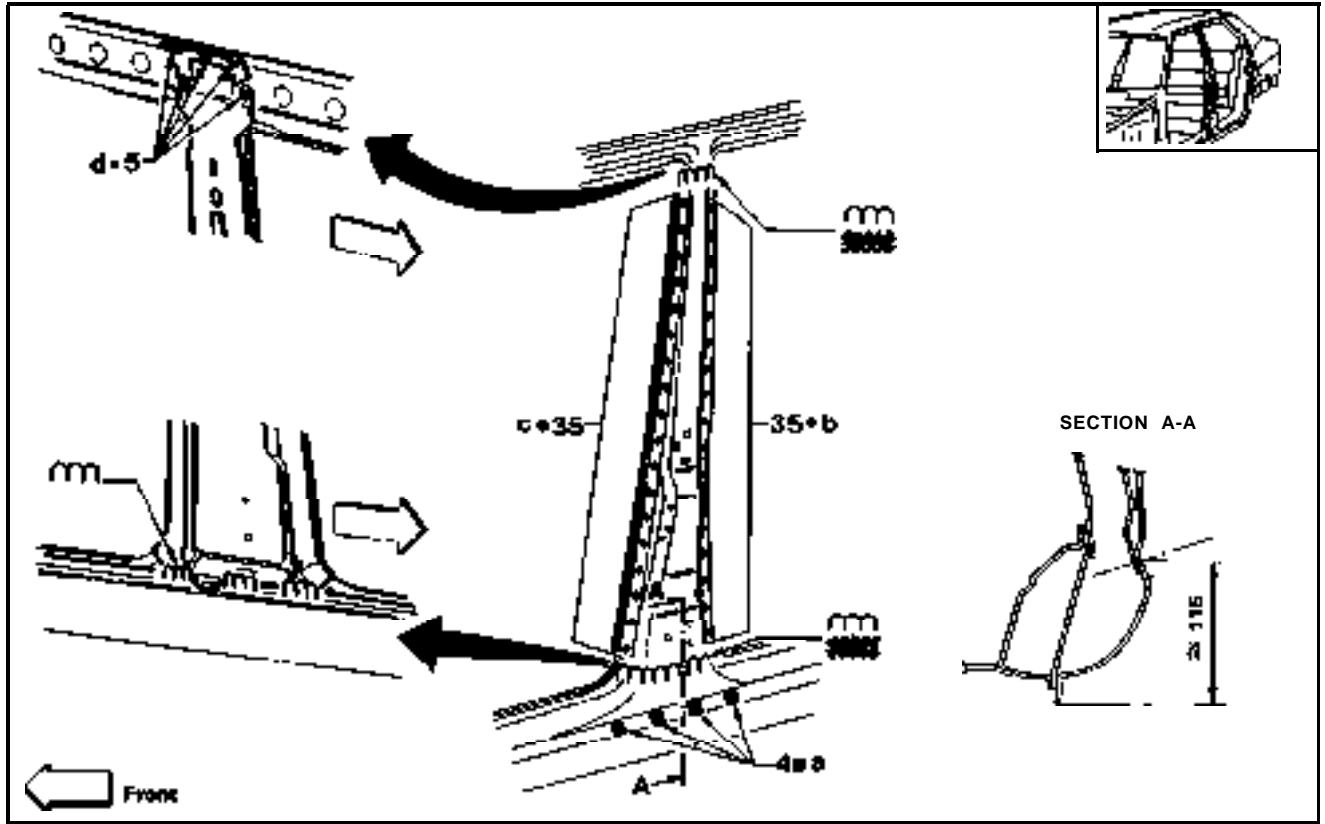

Parts to be welded

- a. Pillar and pillar inner reinforcement
- b. Outer pillar and inner pillar
- c. Outer pillar and inner pillar
- d. Inner pillar and roof panel side member

REMLNDR WHEN REMOVING

- Unscrew the two screws securing rib to roof panel inner side member.
- By means of air saw, cut according to lines A and B, shown in figure.

- -Remove paint in correspondence with the four welding spots of pillar reinforcement lower part at about 115 mm (4.52 in) from lower edge of outer side member (see sect. A-A). Punch the four welding spots and remove the reinforcement part.
- By means of disc sander carry out grinding of continuous welding joining central floor side member ③ to inner central pillar ④.

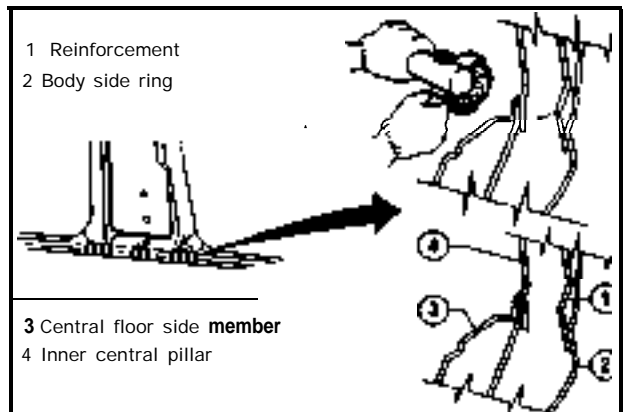
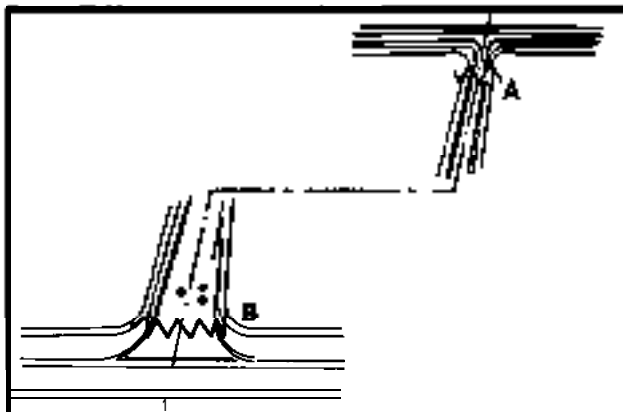

REMINDER WHEN INSTALLING

Precaution when cutting spare pillar

- Cut spare pillar aligned with the upper and lower part of non-replaced pillar part.

- By means of clamps, temporarily secure central pillar. Check component alignment.
- After continuous welding of central pillar, carry out tinning.
- Temporarily secure both front and rear doors.
- Check and adjust clearance, grades and parallelism.

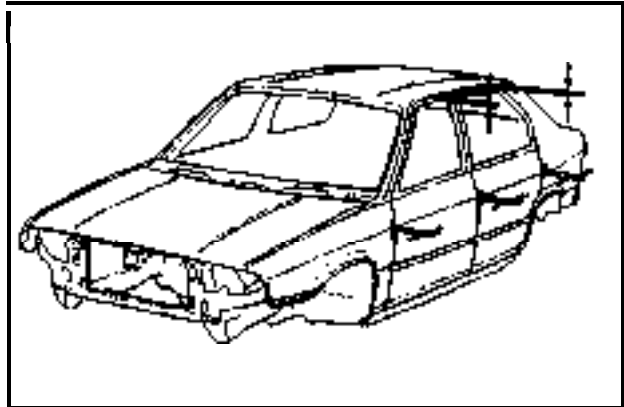
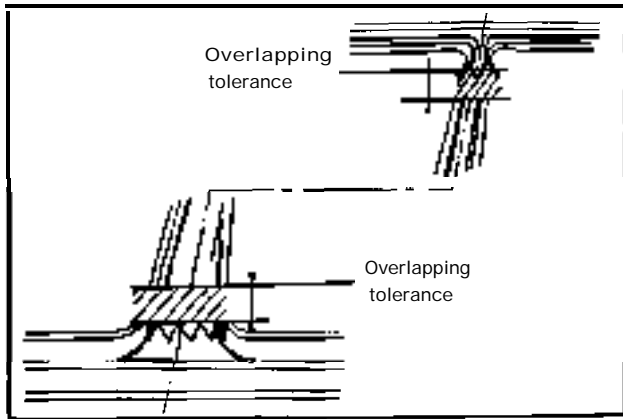

OUTER SIDE MEMBER

Service joints

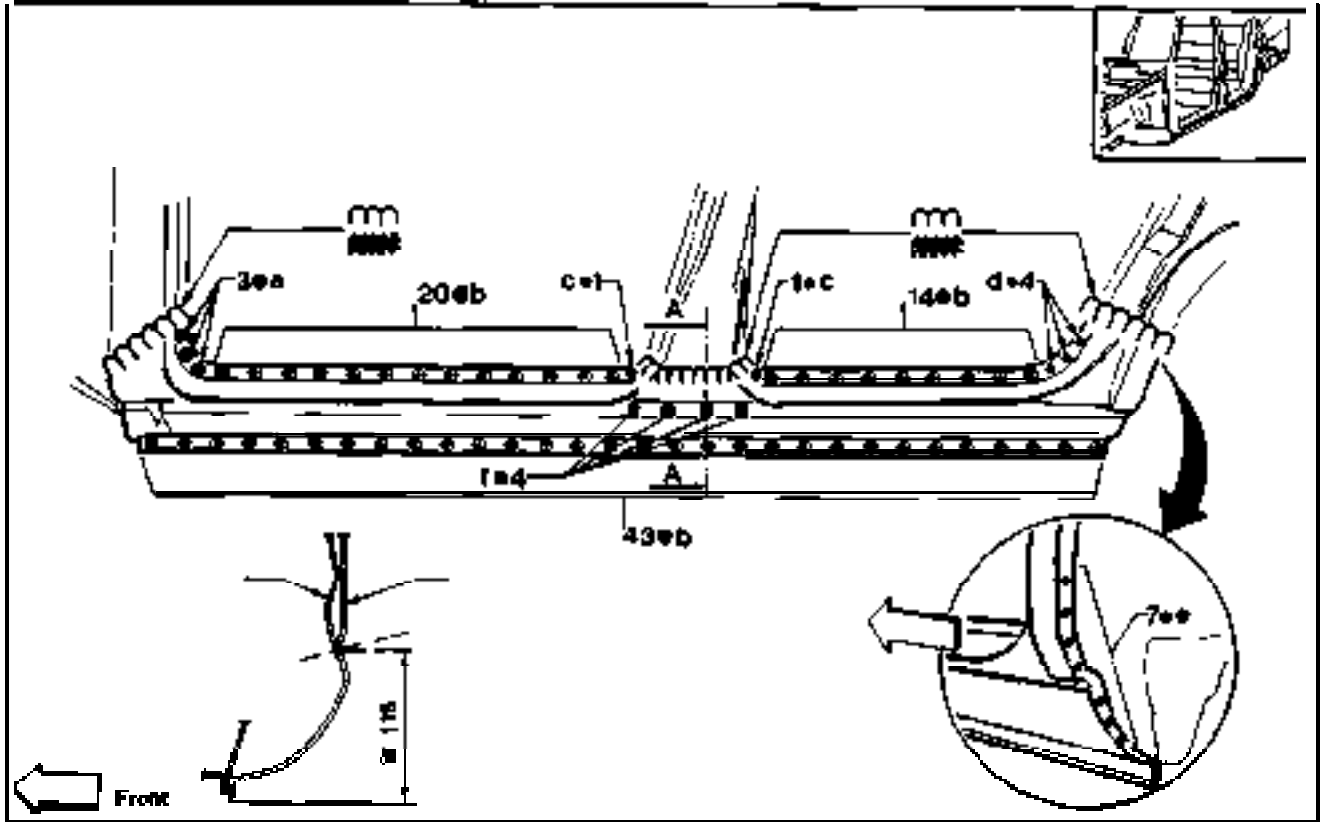

Parts to be welded

- | | |
|-----------------------------------------------------------------------------------------------------------------------------------------------------------------------------------------|----------------------------------------------------------------------------------------------------------------------------------------------------------------------------------------------------------------------------------------------------------------------------|
| <ul style="list-style-type: none"> a. Outer side member, front side member and inner front pillar b. Outer side member, diaphragm and central floor side member | <ul style="list-style-type: none"> c. Outer side member and closing inner central pillar d. Outer side member and inner wheelarch e. Outer side member and outer wheelarch f. Outer side member and central pillar reinforcement |
|-----------------------------------------------------------------------------------------------------------------------------------------------------------------------------------------|----------------------------------------------------------------------------------------------------------------------------------------------------------------------------------------------------------------------------------------------------------------------------|

REMINDER WHEN REMOVING

- By means of air chisel, cut according to line A shown in figure.

- Remove paint in correspondence with the four welding spots of pillar reinforcement lower part at about 115 mm (4.52 in) from lower edge of outer side member (see section A-A). Punch the four welding spots.
- By means of a drilling machine, remove welding spots of the 3-layered sheet joints.

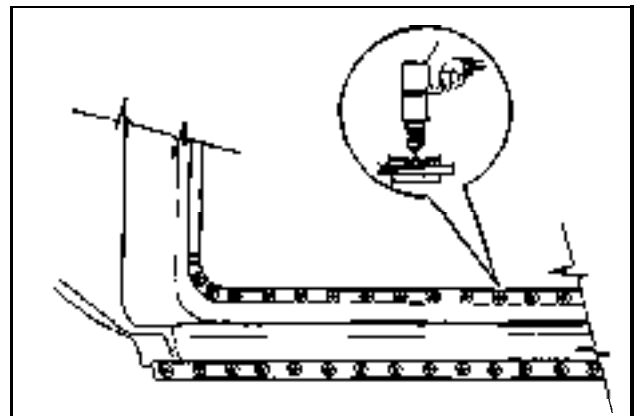
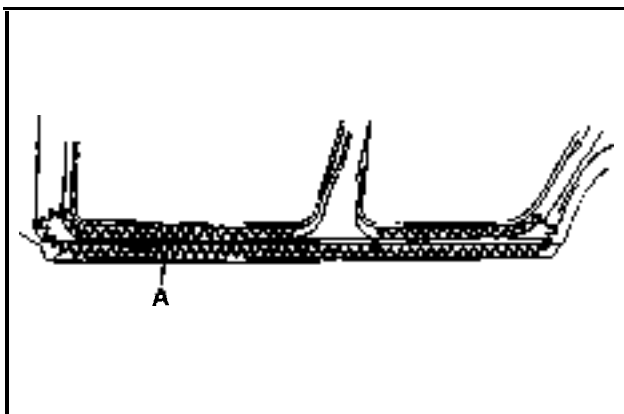

REMINDER WHEN INSTALLING

Precaution during cutting of outer side member

- Cut outer side member aligned with non-replaced panel part

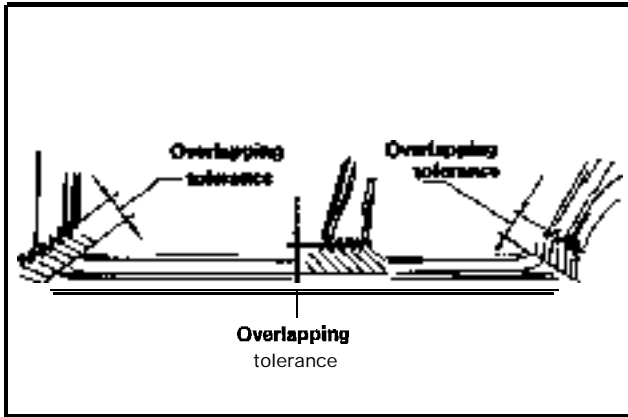

- The continuous welding areas of outer side member to central, front and rear pillar, must be tinned.

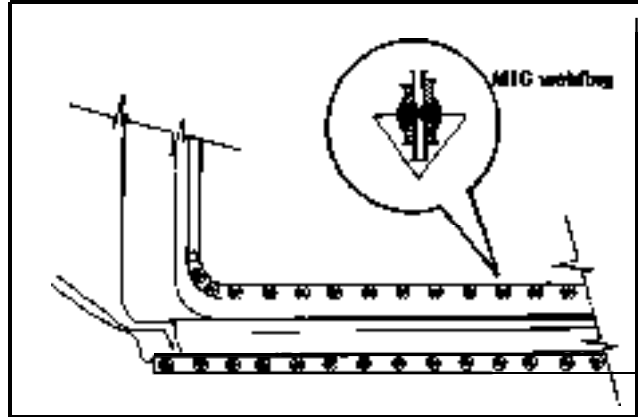

Welding indications

- Use the MIG welding method to weld the three overlapped sheets along the whole perimeter from both sides.

- Apply anti-corrosion agent to boxed part inside.

REMINDER WHEN INSTALLING

Precaution when cutting outer side member

- Cut outer side member aligned with non-replaced panels

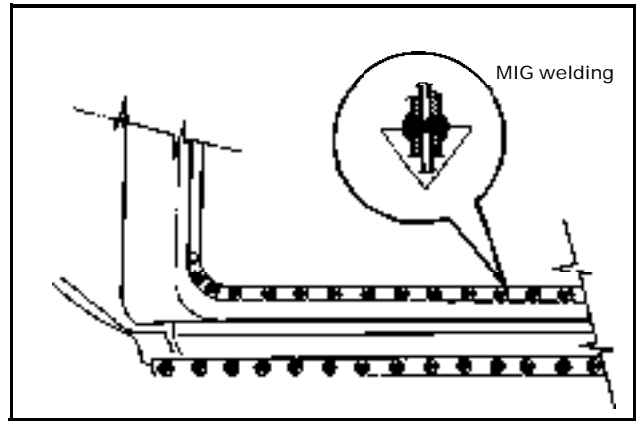
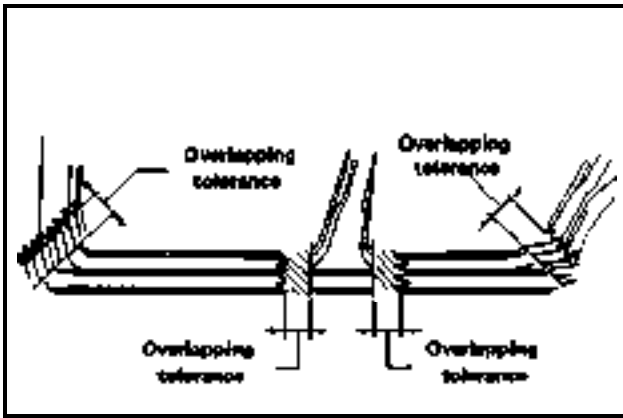

- The continuous welding areas of outer side member to central, front and rear pillar, must be tinned.
- Apply anti-corrosion agent to boxed part inside.

Welding indication

- Use MIG welding method to weld the three overlapped sheets along the whole perimeter from both sides.

REAR FENDER

Service joints

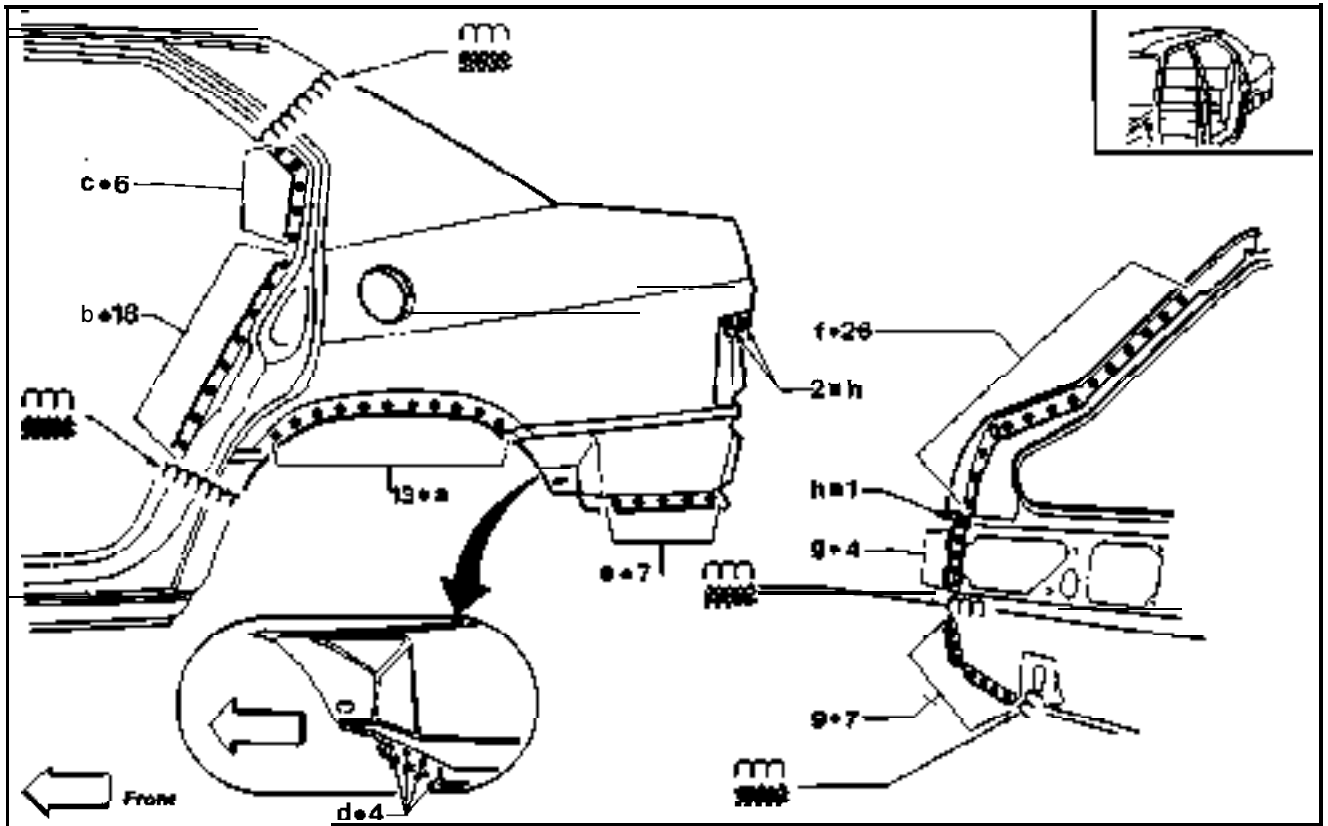

Parts to be welded

- | | |
|-----------------------------------------------------------------------------------------------------------------------------------------------------------------------------------------------------------------|-----------------------------------------------------------------------------------------------------------------------------------------------------------------------------------|
| <ul style="list-style-type: none"> a. Fender and outer wheelarch b. Fender and inner wheelarch c. Fender and inner fender reinforcement d. Fender and outer wheelarch | <ul style="list-style-type: none"> e. Fender and floor f. Fender and drip g. Fender and upper rear panel h. Fender and upper rear panel |
|-----------------------------------------------------------------------------------------------------------------------------------------------------------------------------------------------------------------|-----------------------------------------------------------------------------------------------------------------------------------------------------------------------------------|

REMINDER WHEN REMOVING

- By means of air chisel, cut the area shown in figure.

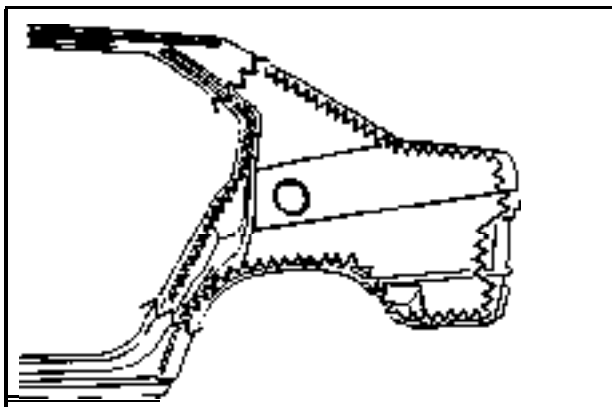

Take care not to cut frame of rear fender.

REMINDER WHEN INSTALLING

Precaution when cutting spare fender

- Cut spare fender aligned with non-replaced panel part.

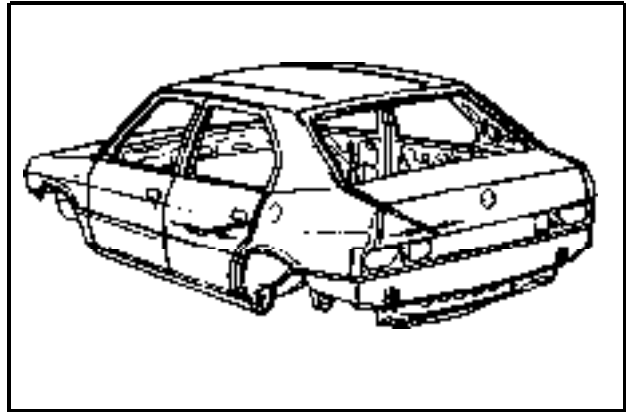
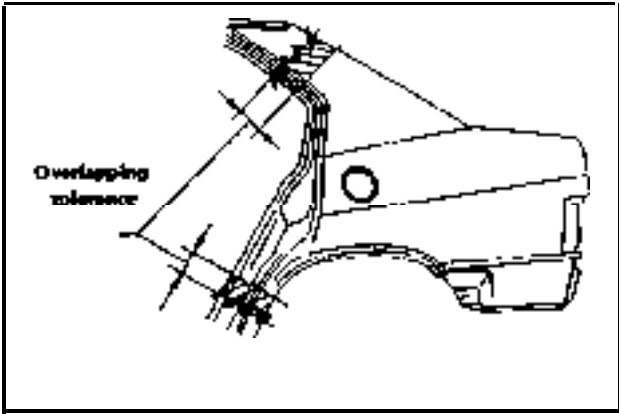

Fender temporary installation

- By means of clamps, temporarily secure rear fender.

- The fender area of continuous welding to roof panel side member, must be tinned.

Sealer application

- Apply sealer to wheelarch outer side.

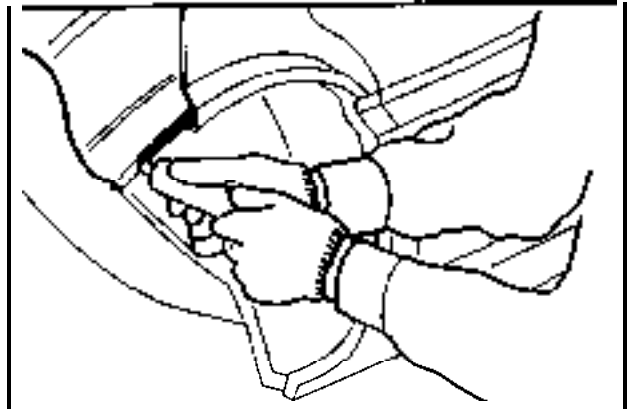
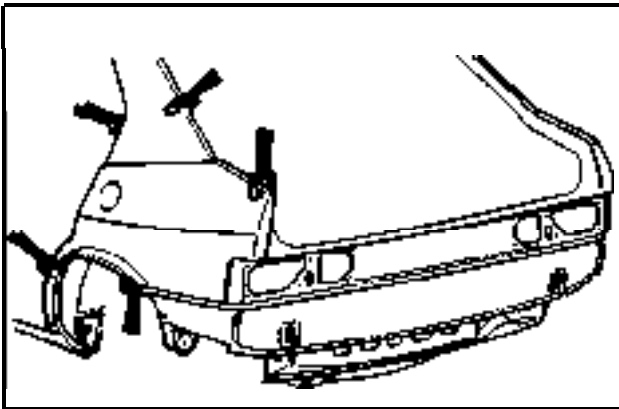

- Temporarily secure the adjacent components: door and backdoor. Check clearances, grades and parallelism.

DRIP WITH REAR FENDER REMOVED

Carry out replacement after Rear Fender has been removed.

Service joints

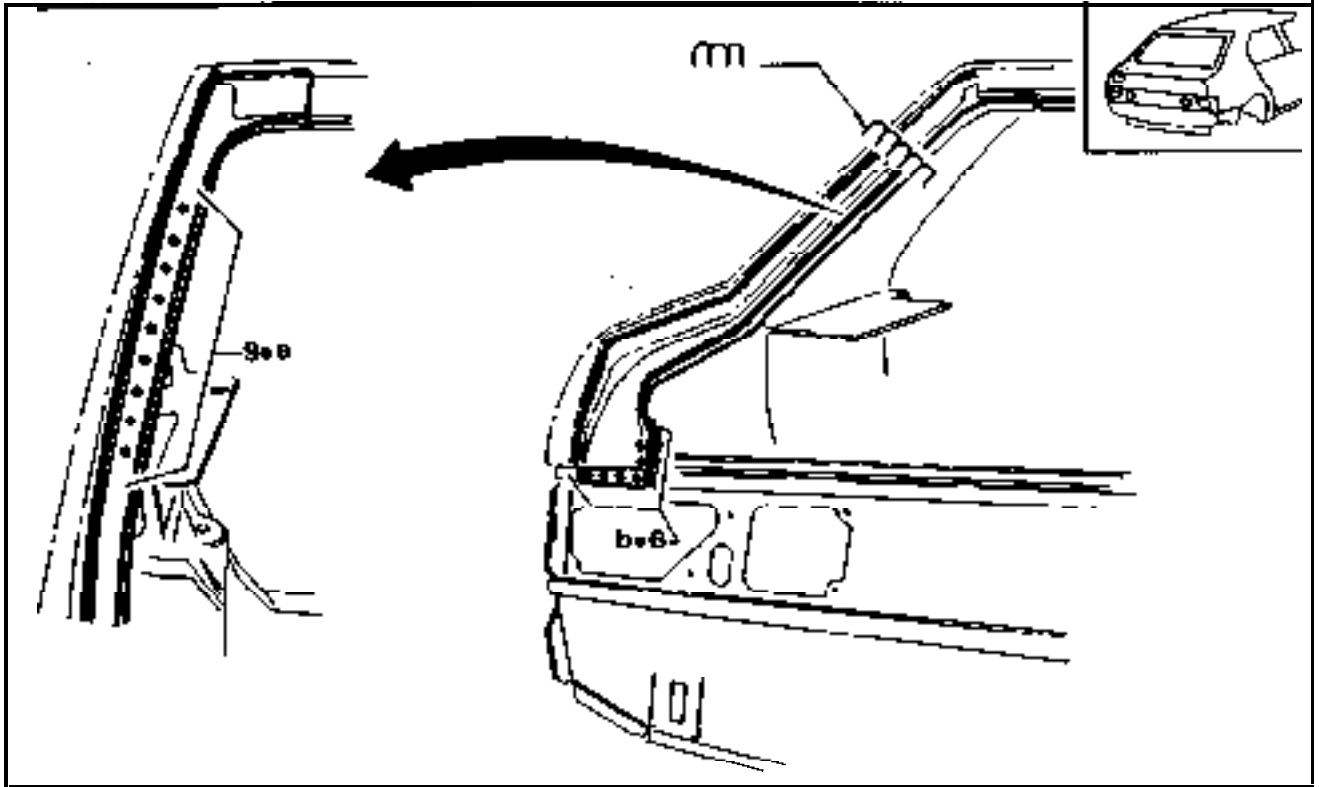

Parts to be welded

- a. Drip and rear fender inner frame
- b. Drip and rear panel,

REMINDER WHEN REMOVING

- By means of air saw cut according to lines A and B shown in figure.

Take care not to cut fender frame.

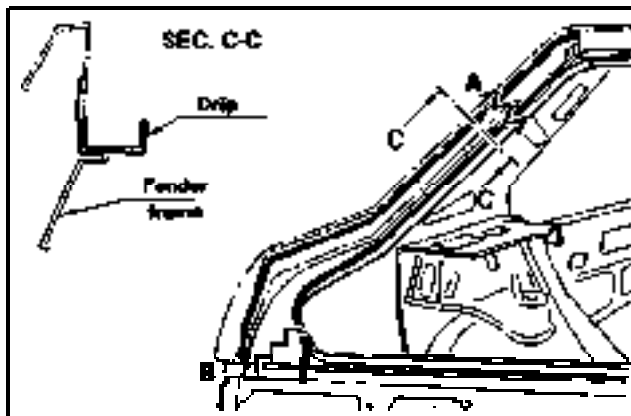

REMINDER WHEN INSTALLING

Caution when cutting spare drip

- Cut spare drip aligned with the non-replaced drip part.

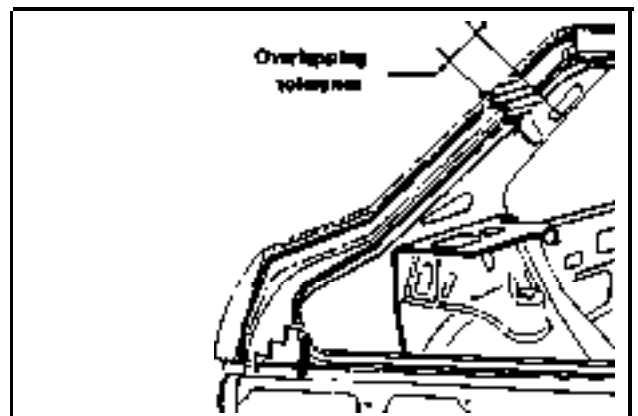

LOWER REAR PANEL

Service joints

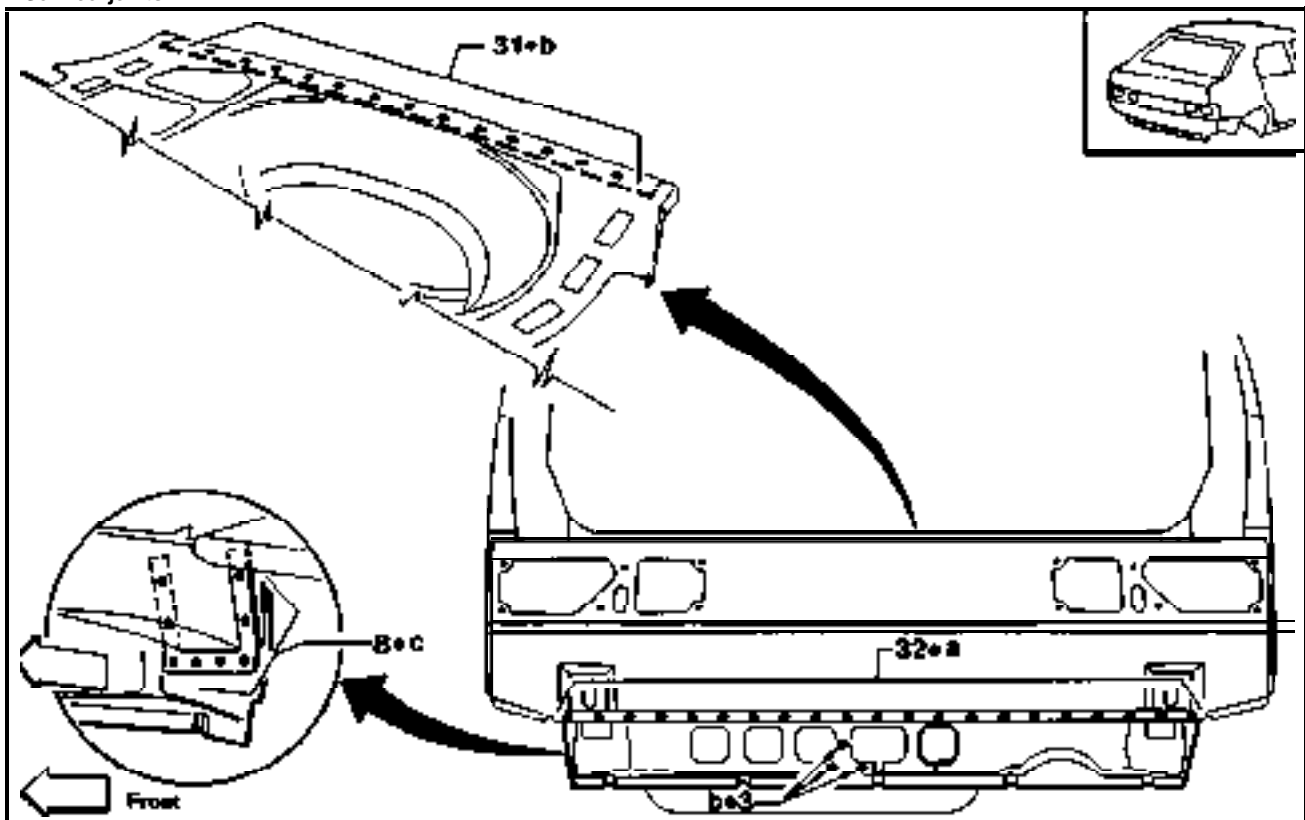

Parts to be welded

- a. Cross member and rear panel
- b. Cross member and floor
- c. Cross member and side member

REMINDER WHEN REMOVING

- By means of a saw, cut areas A and B taking care not to cut central area, mentioned in the figure, in order not to cut floor in correspondence with spare wheel compartment.
- Punch junction points of lower rear panel to rear floor of spare wheel area.

Precaution during welding

- For the spot welding, make use of a brass wire.

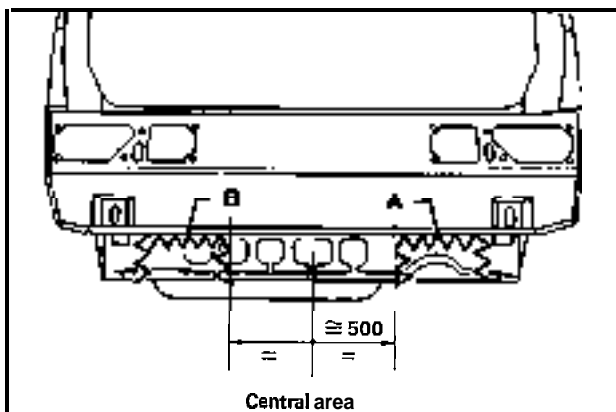

UPPER REAR PANEL

Service joints

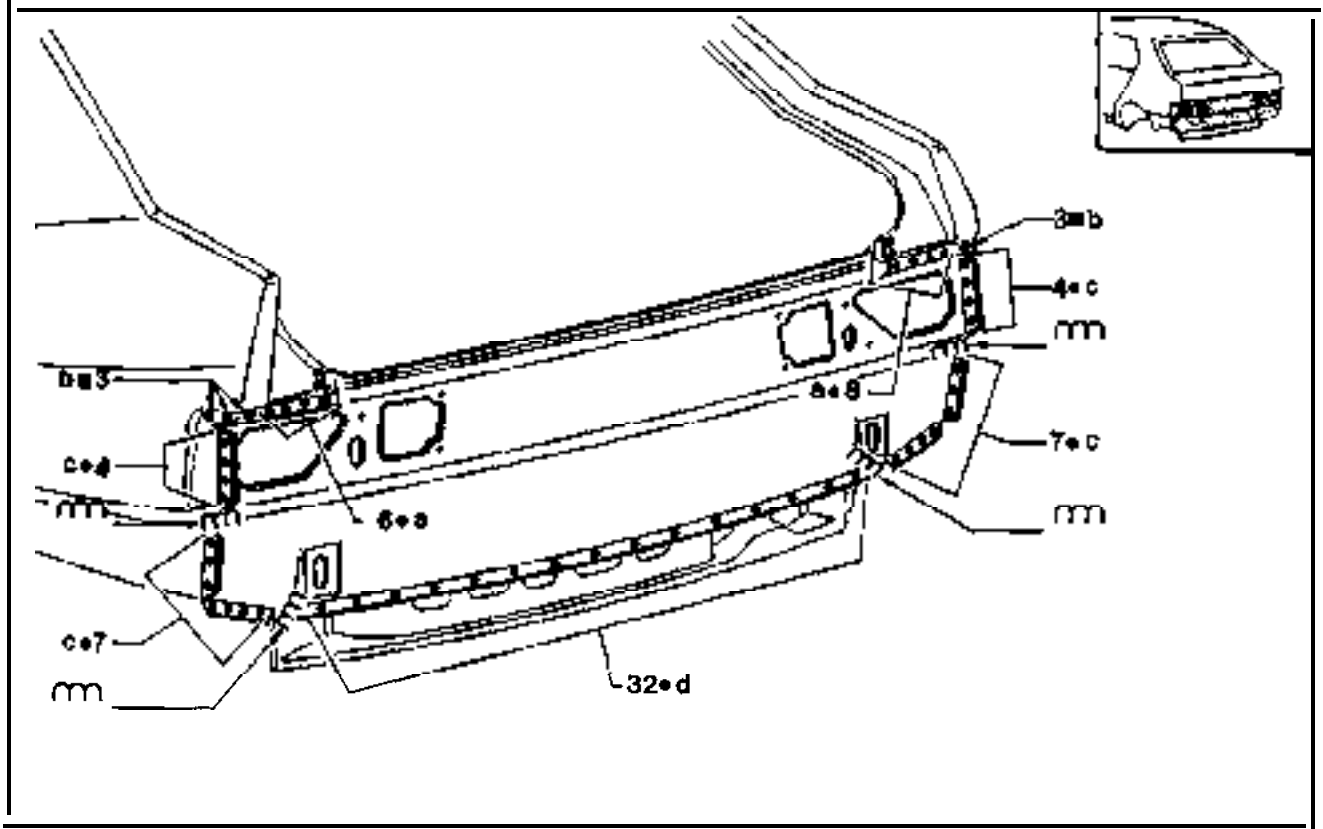

Parts to be welded

- a. Rear panel and drip
- b. Rear panel and outer fender
- c. Rear panel and outer fender
- d. Rear panel and floor

REMINDER WHEN REMOVING

- By means of air saw, cut according to line A.

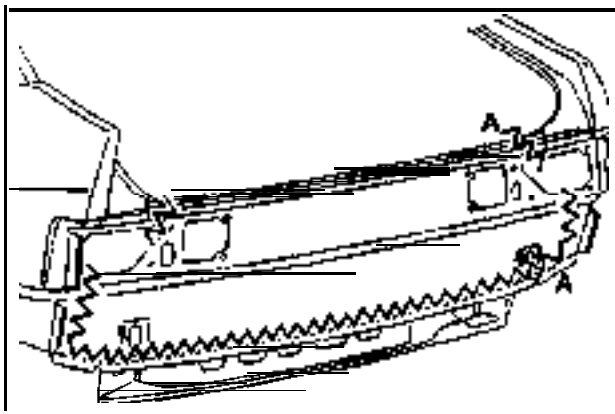

REMINDER WHEN INSTALLING

- By means of clamps, temporarily secure the upper rear panel.

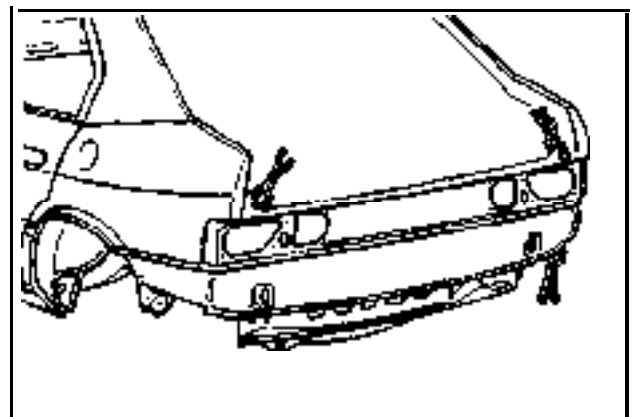

BODY – SHEET METAL PANELS

- Temporarily secure backdoor and check clearances, grades and parallelisms. Check correct positioning and alignment of bumper to rear panel.

Precaution during welding

- For the spot welding, make use of a brass wire.

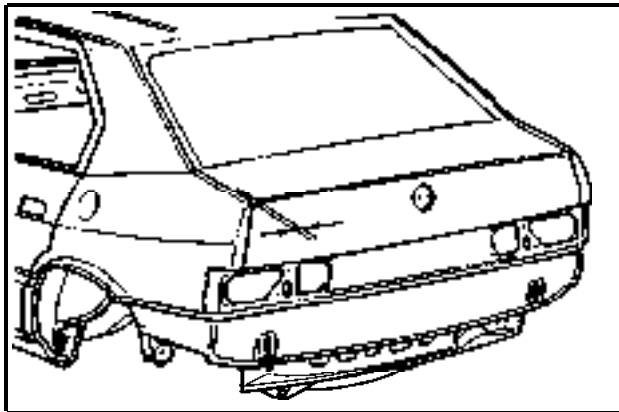

REAR PART OF REAR FLOOR WITH REAR FENDER AND REAR PANEL REMOVED

Carry out replacement after Rear Fender and both Lower and Upper Rear Panel have been removed.

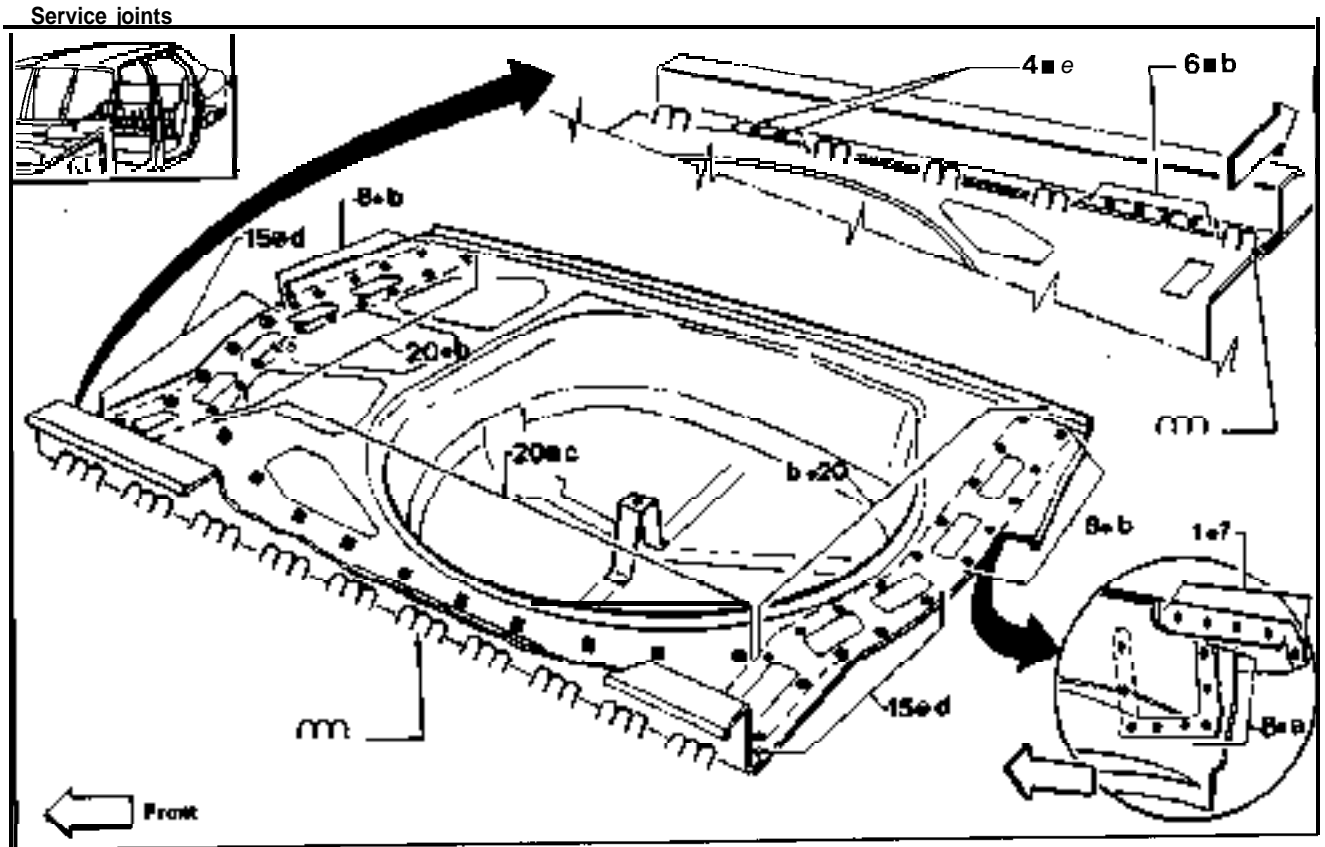

Parts to be welded

- | | |
|----------------------------------------------------------------------------------------------------------------------------------------------------------------------------------|-------------------------------------------------------------------------------------------------------------------------------------------------------------------------------------------------------|
| <ul style="list-style-type: none"> a. Rear floor and rear side member b. Rear floor and rear side member c. Rear floor and central cross member | <ul style="list-style-type: none"> d. Rear floor, rear side member and inner rear wheelarch e. Rear floor and rear seat cross member f. -Rear floor and outer fender |
|----------------------------------------------------------------------------------------------------------------------------------------------------------------------------------|-------------------------------------------------------------------------------------------------------------------------------------------------------------------------------------------------------|

REMINDER WHEN REMOVING

- By means of air saw, cut according to line A.
- By means of a drilling machine, remove welding spots from the S-layered sheets joints.

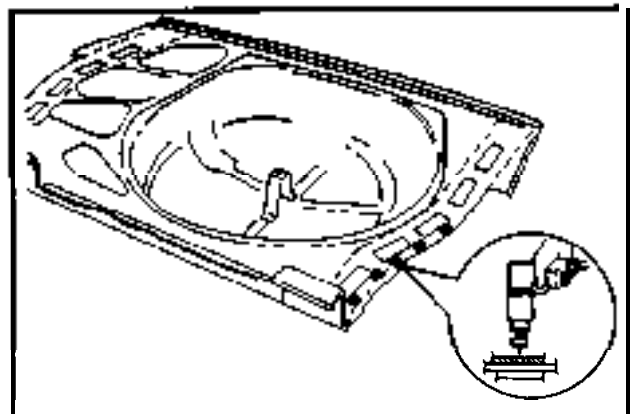
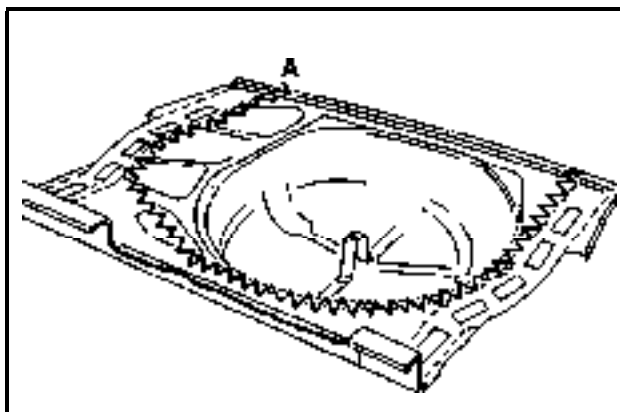

REMINDER WHEN INSTALLING

- Secure rear floor temporarily and carry out marking along side member and cross member from floor underside.
This easy drilling operation of the MIG welded spots.
- In order to obtain the best welding result, make use of spot welder as far as possible.
- Carry out holes for the MIG welding in the rear floor where spot welder can not be used.
- In rear floor installation, temporarily secure fender and rear panel.
Check installation dimensions in accordance with drawings provided in "Body Alignment".
- With the components temporarily secured, carry out temporaneous MIG weldings in some points of rear floor.

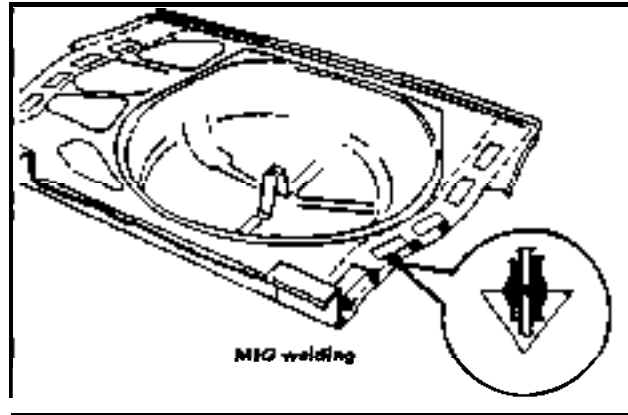

- Apply sealant to non-replaced surfaces of rear wheel-arch and of floor, in accordance with "Body Sealing".
- Apply anti-corrosion agent to weldings under floor, then apply primer.

REMINDER WHEN INSTALLING

- After temporary securing of side member to rear floor, carefully check dimensions provided in “Body Alignment”.

REMINDER WHEN INSTALLING

- Before carrying out welding, apply the adhesive to joints between roof and central rib.
- Apply sealant to the areas indicated in “Body Sealing”.
- Carry out tinning in the areas between roof and rear fender, which are continuous welded.

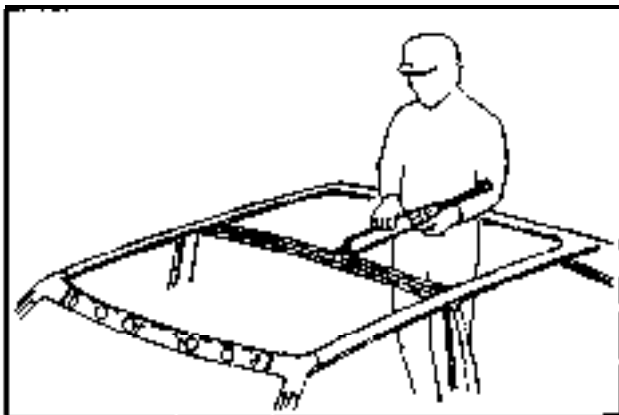

DOORS

GROUP 55

CONTENTS

FRONT DOOR	55-2	Internal finishing panels	55-7
Door assembly	55-3	Fixed glasses	55-7
Internal finishing panels	55-3	Window regulator devices and	
Window regulator devices and		glasses	55-7
glasses	55-3	Door locks and handles	55-8
Door locks and handles	55-4	Moldings and seals	55-8
Door mirror	55-4	SERVICE DATA AND	
Moldings and seals	55-4	SPECIFICATIONS.	55-9
REAR DOOR	55-6	Tightening torques	55-9
Door assembly.	55-7		

FRONT DOOR

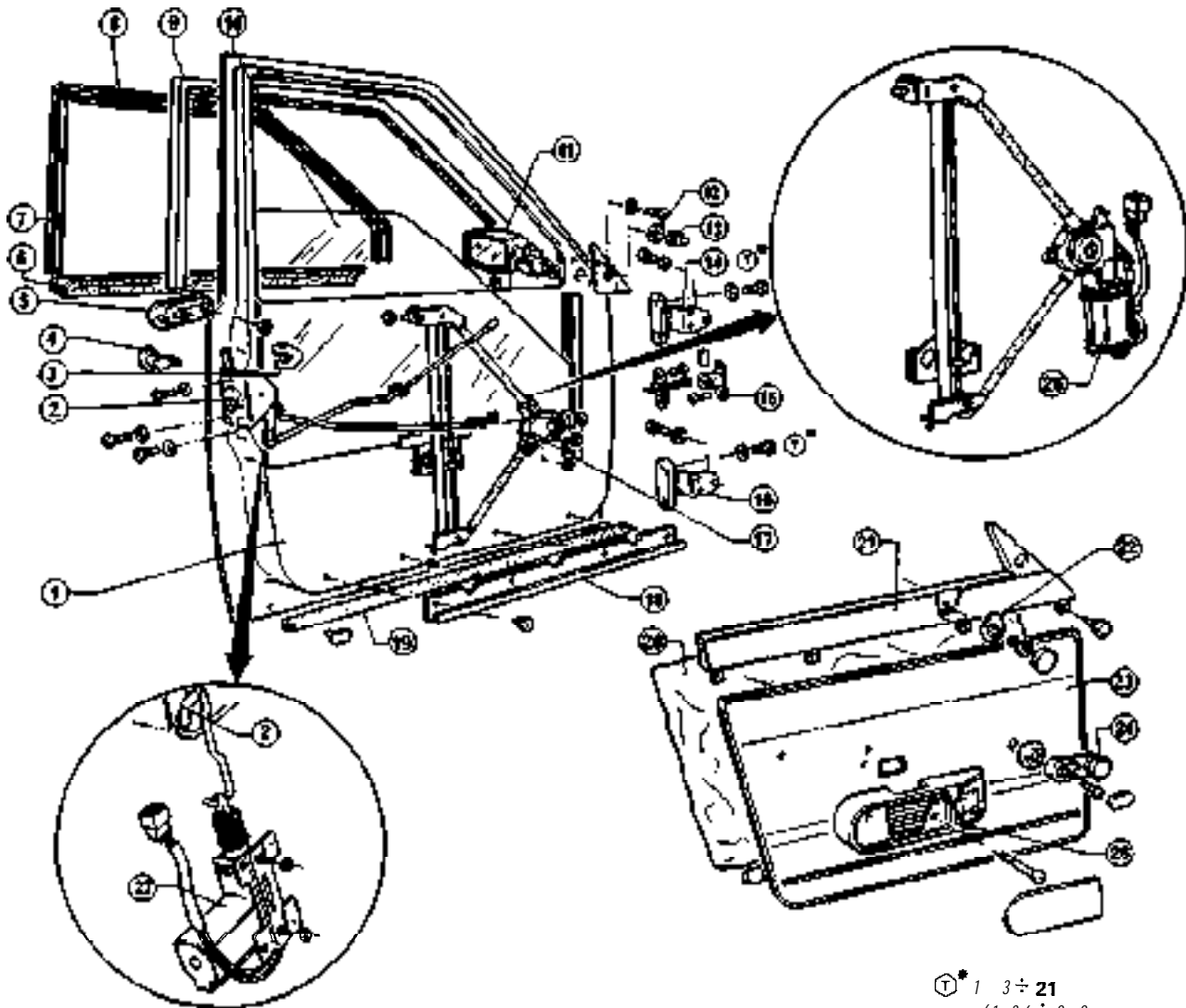

⊕* 1 3 ÷ 21
 (1.36 ÷ 2.2
 9.83 ÷ 15.9)

⊕ N·m
 (kg·m
 ft·lb)

- | | |
|-------------------------------|------------------------------------------------------------|
| 1 Door | 15 Tie rod |
| 2 Door lock device | 16 Hinge |
| 3 Lock block clamp plate | 17 Window regulator device |
| 4 Lock block | 18 Panel lower clamps |
| 5 Handle | 19 Seal |
| 6 Molding and weatherstrip | 20 Sealing screen |
| 7 Molding | 21 Upper trim and weatherstrip |
| 8 Molding | 22 Door lock control |
| 9 Glass velvet seal with trim | 23 Panel |
| 10 Glass | 24 Window regulator handle |
| 11 Door mirror | 25 Arm rest |
| 12 Ring nut | 26 Power window switch (1500 and 1500 Quadrifoglio models) |
| 13 Rubber | 27 Power door locks device (1500 Quadrifoglio model) |
| 14 Hinge | |

DOOR ASSEMBLY

REMOVAL AND INSTALLATION

With reference to exploded view proceed as follows:

1. Disconnect door from tie rod and from hinges (14) and (16) by unscrewing the six screws, then remove it.

1a. Only for the 1500 and 1500 Quadrifoglio models.

Disconnect harness and then proceed as per step 1.

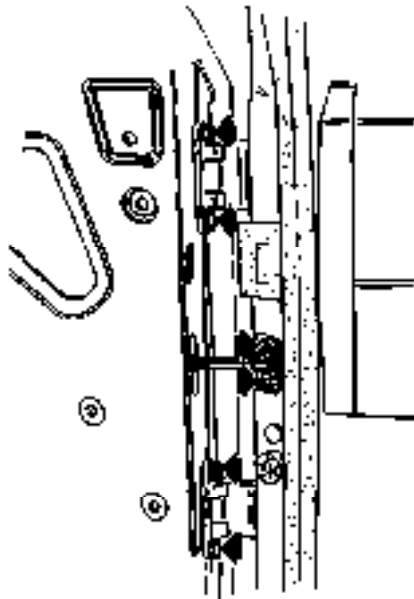

2. For door installation reverse order of removal and tighten screws securing hinges to door to the prescribed torque.

Ⓣ : Tightening torque

Screws securing hinges to door
 $13 \div 21\text{N}\cdot\text{m}$
 $(1.36 \div 2.2 \text{ kg}\cdot\text{m})$
 $9.83 \div 15.9 \text{ ft}\cdot\text{lb}$

INTERNAL FINISHING PANELS

Cover end of the tool used for removing plastic rivets in order not to damage or scratch the body.

REMOVAL AND INSTALLATION

1. Lift ornament of arm rest (25) and unscrew the three securing

screws, then remove it.

2. Remove ornament covering the door securing screws, then remove window regulator handle (24).

3. Remove plastic rivets securing panel (23) to door. Remove panel by bending it.

4. Remove plastic rivets securing upper trim (21) to door.

5. Remove hook of door lock control rod. then remove upper trim (21),

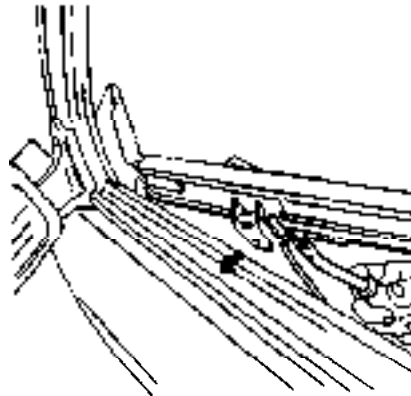

6. For upper trim and panel installation, reverse order of removal.

WINDOW REGULATOR DEVICES AND GLASSES

REMOVAL AND INSTALLATION

1. Remove panel (23), upper trim (21) and sealing screen (20).

2. Lower glass (10) completely, unscrew the two nuts securing window regulator device (17) to glass, then remove by rotating it.

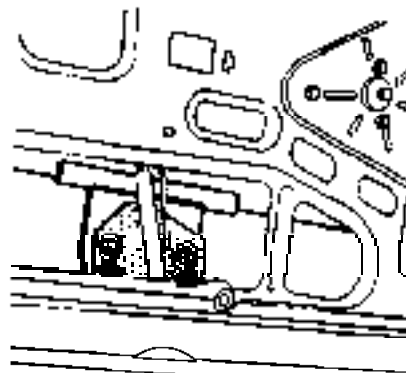

3. Unscrew the five nuts securing window regulator (17) to door, then remove it.

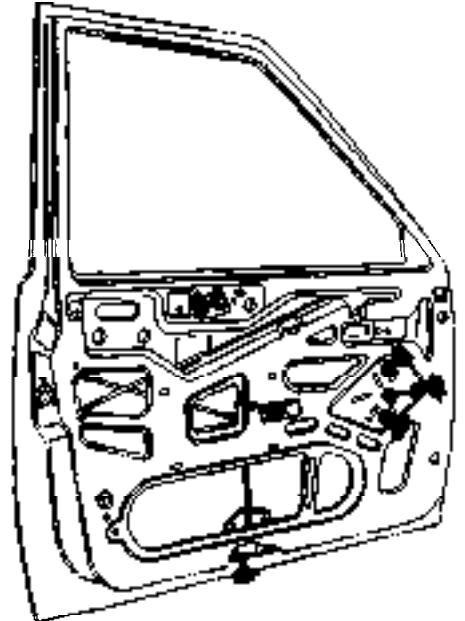

3a. Only for 1500 and 1500 Quadrifoglio models

Disconnect harness of window regulator motor, unscrew the five nuts securing power window (26) to door, then remove it.

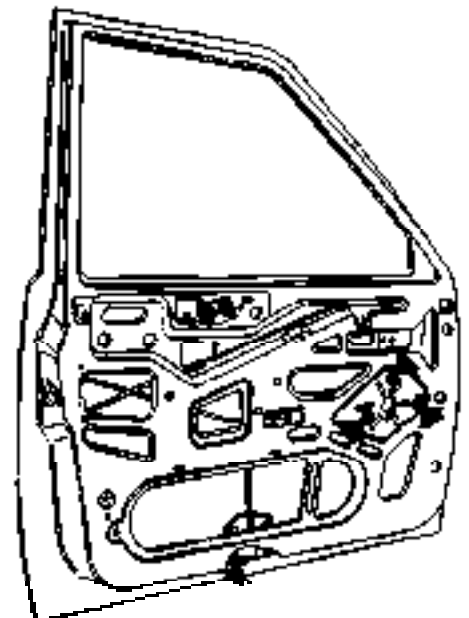

4. Install window regulator and glass by reversing order of removal.

DOOR LOCKS AND HANDLES

REMOVAL AND INSTALLATION

1. Remove panel (23), upper trim (21) and move sealing screen (20).
2. Lift glass (10) completely in order to avoid damage.
3. Remove plastic fasteners securing levers to door.

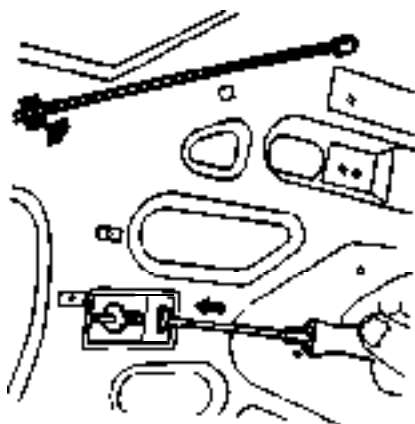

4. 1500 Quadrifoglio model

- Release connecting rod between lock (2) and door lock electric device (27). To remove it, if necessary, disconnect harness, and unscrew the two nuts securing it to door.

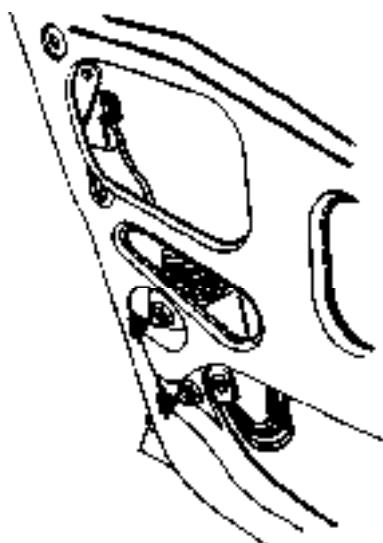

5. Release connecting rod between lock block (4) and lock (2).

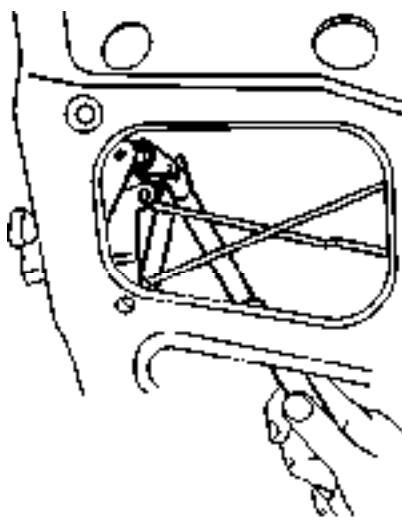

6. Withdraw clamp plate of lock block (3) by means of proper tool and remove lock block (4).

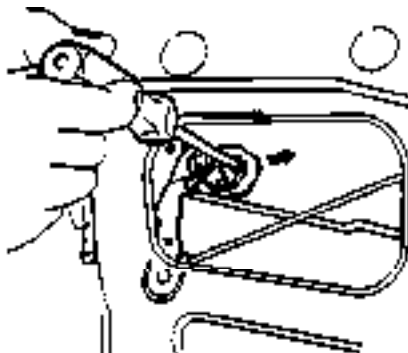

7. Unscrew the three screws securing lock (2) to door then remove lock.
8. Unscrew the two nuts securing handle (8) to door, then remove handle.



9. Install handle and lock by reversing order of removal.
10. Verify proper functioning of door opening control and, if necessary, loosen the three screws securing door lock clamp and move it until perfect closing is obtained.

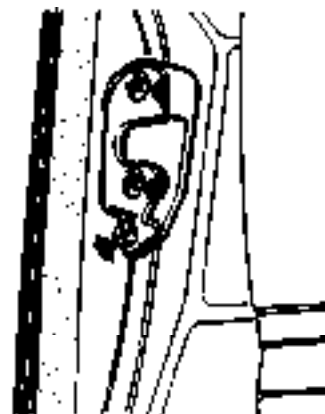

DOOR MIRROR

REMOVAL AND INSTALLATION

1. Remove panel (23) and upper trim (21).
2. Withdraw rubber (13) and unscrew the two screws securing mirror (11) to door.
3. Unscrew ring nut (12) and remove door mirror (11).
4. Install door mirror by reversing order of removal.

MOLDINGS AND SEALS

Cover end of the tool used for removing moldings in order not to damage or scratch the body.

REMOVAL AND INSTALLATION

1. Operating as per figure, remove molding with weatherstrip (6).

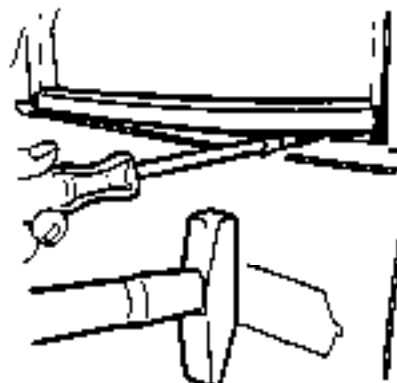

DOORS

2. Remove molding ⑧.
3. Remove panel ②③ and upper trim with weatherstrip ②①.
4. Remove door mirror ①①.
5. Remove molding 7 .
6. Remove glass ⑧① and glass velvet with trim ⑨.
7. Reposition moldings and seals by reversing order of removal.
8. With reference to the following figure take care to secure glass velvet seal on clamp ② of glass guide ① located inside the door.

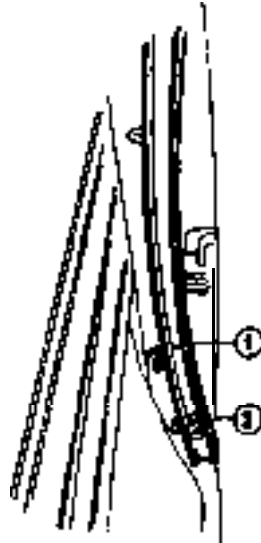

- 1 Glass guide
- 2 Glass velvet seal clamp

CAUTION:

Apply proper grease to hinges, tie rod and door lock device.

REAR DOOR

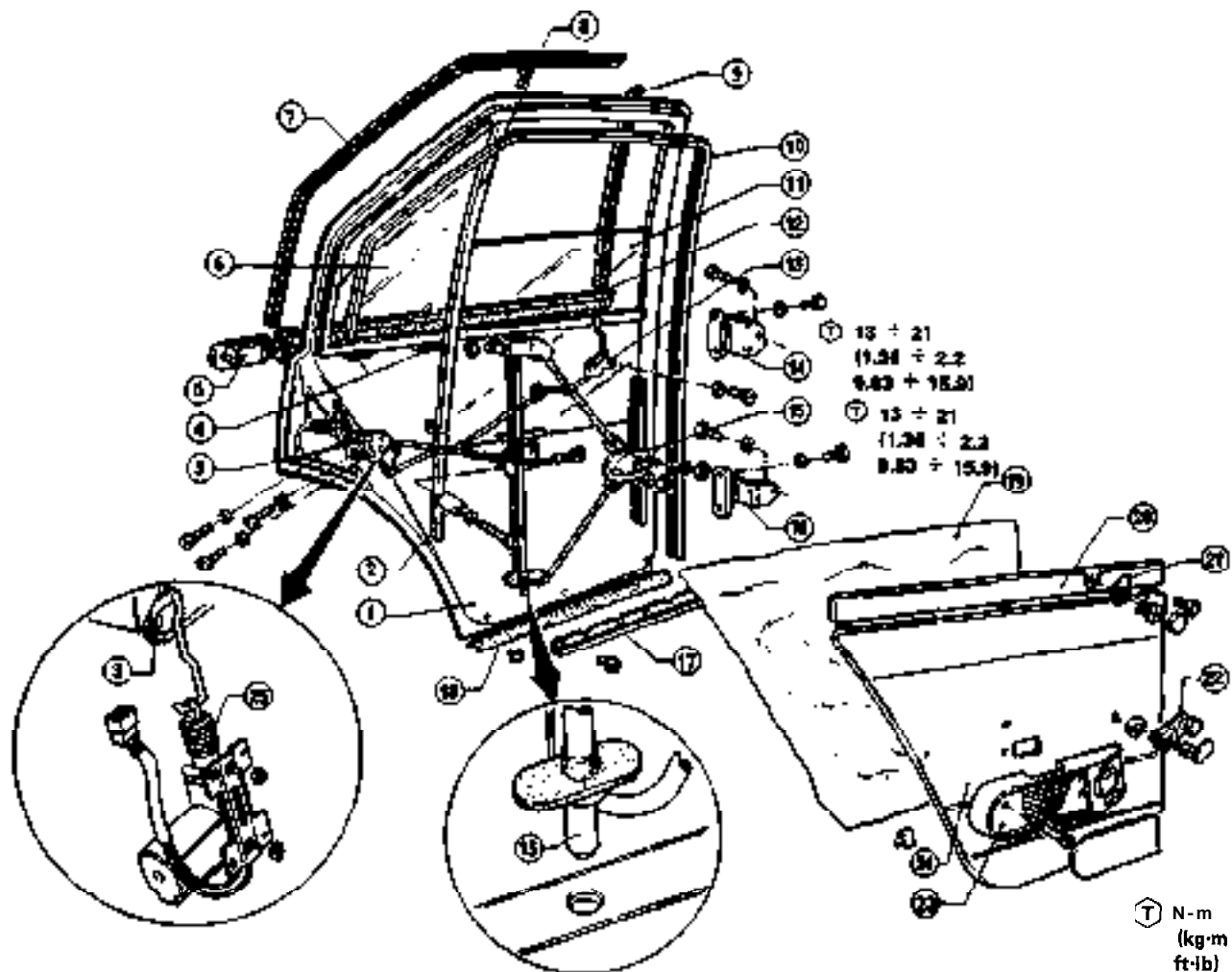

- | | |
|--------------------------------|--------------------------------------------------------|
| 1 Door | 14 Hinge |
| 2 Spacer | 16 Window regulator device |
| 3 Door lock device | 16 Hinge |
| 4 Rubbers | 17 Panel lower clamp |
| 5 Handle | 18 Seal |
| 6 Fixed glass | 19 Sealing screen |
| 7 Molding | 20 Upper trim and weatherstrip |
| 8 Fixed glass guide | 21 Door lock control |
| 9 Molding | 22 Window regulator handle |
| 10 Glass velvet seal with trim | 23 Arm rest |
| 11 Glass | 24 Panel |
| 12 Molding and weatherstrip | 25 Door lock electric device (1500 Quadrifoglio model) |
| 13 Door lock control | |

DOOR ASSEMBLY

REMOVAL AND INSTALLATION

With reference to exploded view proceed as follows:

1. Unscrew the four screws securing hinges (14) and (16) to door and remove it.

1a. Only for the 1500 and 1500 Quadrifoglio models.

Disconnect harness and then proceed as per step 1.

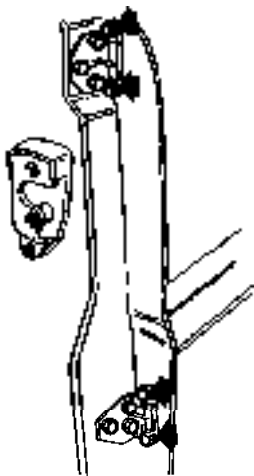

2. For door installation reverse order of removal, tighten screws securing hinges to door to the prescribed torque:

(T): Tightening torque

Screws securing hinges to door
 $13 \div 21 \text{ N}\cdot\text{m}$
 $(1.36 \div 2.2 \text{ kg}\cdot\text{m})$
 $9.83 \div 15.9 \text{ ft}\cdot\text{lb}$

INTERNAL FINISHING PANELS

Cover end of the tool used for removing plastic rivets in order not to damage or scratch the body.

REMOVAL AND INSTALLATION

1. Lift ornament of armrest (23) and unscrew the three securing screws, then remove it.

2. Remove ornament covering the door securing screw, then remove window regulator handle (22).

3. Remove plastic rivets securing panel (24) to door. Remove panel by bending it.

4. Remove plastic rivets securing upper trim (20) to door.

5. Remove hook of door lock control rod, then remove upper trim (20).

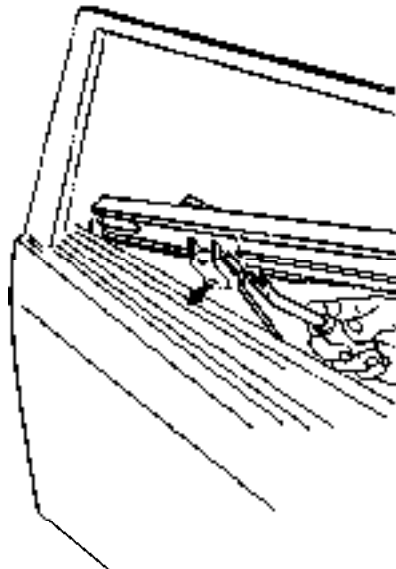

6. For upper trim and panel installation, reverse order of removal.

FIXED GLASSES

REMOVAL AND INSTALLATION

1. Remove panel (24), upper trim (20) and lower completely glass (11).

2. Unscrew the screw securing fixed glass guide (8) to door, move sealing screen (19) and recover spacer (2).

3. Unscrew the screw securing fixed glass guide (8) to door frame.

4. Slightly detach the glass velvet seal (10) in correspondence with fixed glass guide (8) and remove guide.

5. Remove fixed glass.

6. Install fixed glass by reversing order of removal.

WINDOW REGULATOR DEVICES AND GLASSES

REMOVAL AND INSTALLATION

1. Remove panel (24), upper trim (20) and sealing screen (19).

2. Lower completely glass (11) and windscreens the two nuts securing window regulator device to glass.

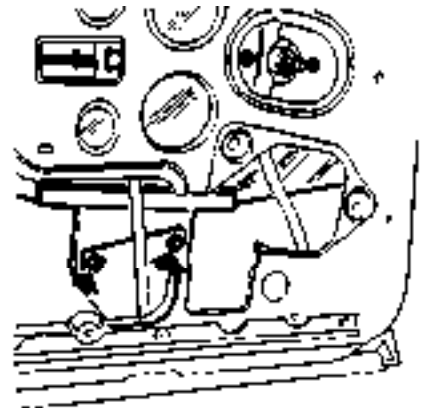

3. Unscrew the three nuts securing window regulator (15) to door and remove it from lower side by lifting glass (11).

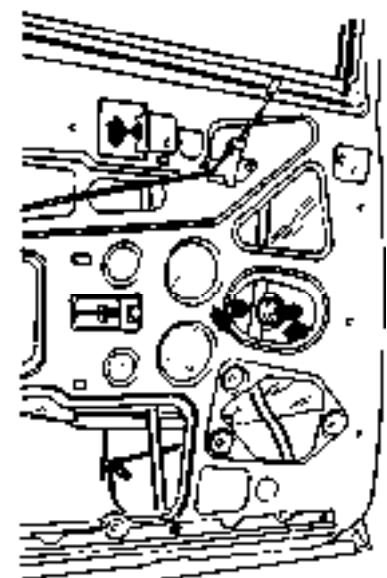

4. Remove fixed glass guide (8) and fixed glass (6).

5. Remove glass (11).

6. Install glass and window regulator by reversing order of removal.

DOOR LOCKS AND HANDLES

REMOVAL AND INSTALLATION

1. Remove panel (24), upper trim (20) and move sealing screen (19).
2. Lift glass (11) completely in order not to damage it.
3. Release door lock control rod (13) from door lock (3).

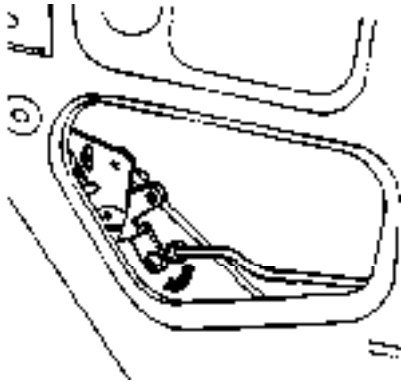

4. Unscrew from door the door lock control rod (13) securing screw and remove it.

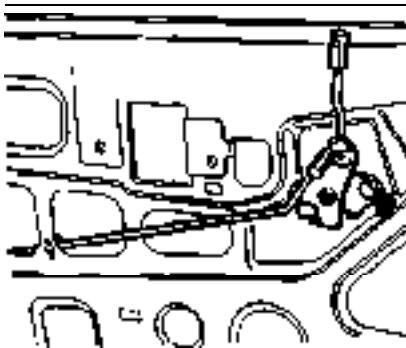

5. Release from door the door opening control rod.

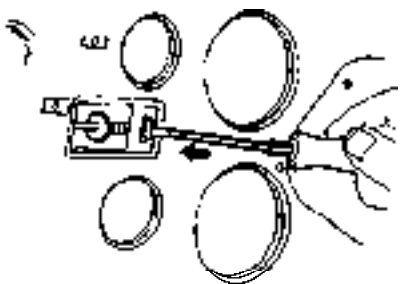

6. Only for 1500 Quadrifoglio model

Release connecting rod between lock (3) and door lock electric device (25). To remove it, if necessary, disconnect harness and unscrew the two nuts securing it to door.

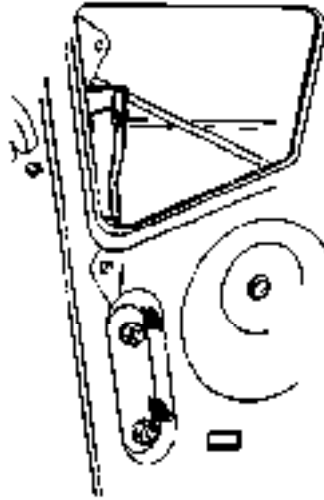

7. Unscrew the three screws securing lock (3) to door, then remove lock.

8. Unscrew the two nuts securing handle (5) to door, then remove handle.

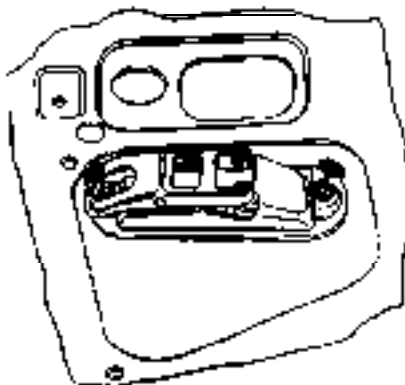

9. Install handle and lock by reversing order of removal.

10. Verify proper functioning of door opening control and, if necessary, loosen the three securing screws of lock clamp and move it until perfect closing is obtained.

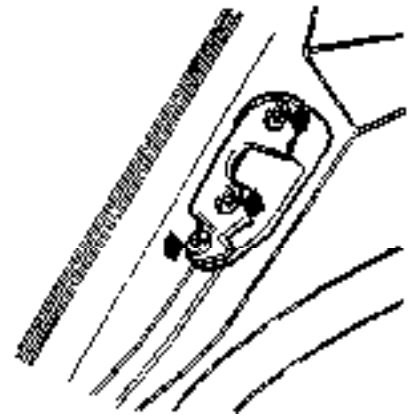

MOLDINGS AND SEALS

Cover end of the tool used for removing moldings in order not to damage or scratch body.

REMOVAL AND INSTALLATION

1. Operating as per figure, remove molding with weatherstrip (12).

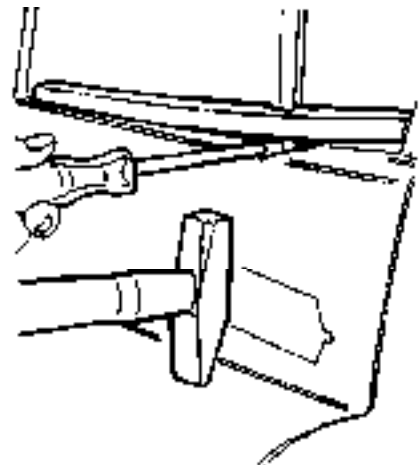

2. Remove molding (7) and (9).
3. Remove panel (24) and upper trim with weatherstrip (20).
4. Remove fixed glass-guide (8), fixed glass (6) and glass (11).
6. Remove glass velvet seal with trim (10).

DOORS

6. Reposition moldings and seal by reversing order of removal.
7. With reference to the following figure, take care to secure glass velvet seal on clamp ② of glass guide ① located inside the door.

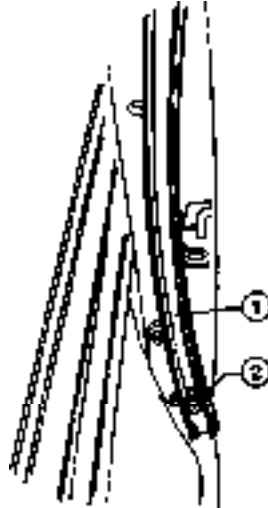

1 Glass guide
2 Glass velvet seal clamp

CAUTION:

Apply proper grease to hinges and door lock device.

SERVICE DATA AND SPECIFICATIONS

TIGHTENING TORQUES

	Unit			
Item		N·m	kg·m	ft·lb
Screws securing hinges to front door		13-21	1.36 ÷ 2.2	9.83 ÷ 15.9
Screws securing hinges to rear door		13 ÷ 21	1.36 ÷ 2.2	9.83 ÷ 15.9

HOODS

HOOD POSITION ADJUSTMENT

Loosen the four screws securing hinges to hood and move hood forward, backward and side to side until correct position is obtained.

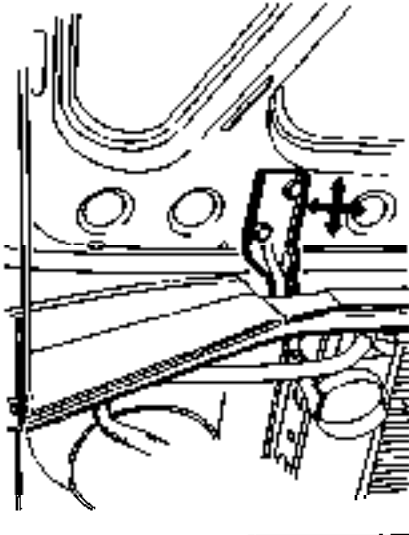

CAUTION:

- During installation of hood lock ② make sure that striker

rod is positioned in the center of hood lock slit by operating on the two screws ①. Then, temporarily tighten the lock.

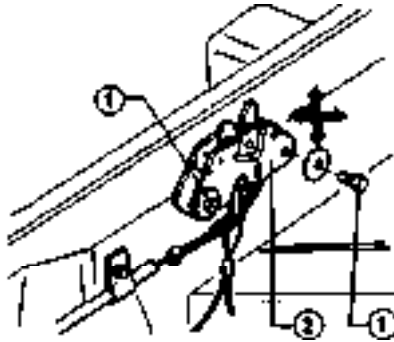

1 Screws

2 Hood lock device

- With the hood lock temporarily tightened to body, verify that hood bumper ②, located on hood ①, come in contact with body ③; if not so, properly change hood bumper height by screwing or-unscrewing them.

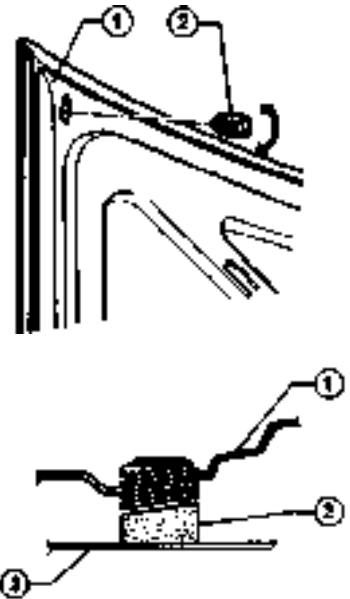

1 Hood

3 Body

2 Hood bumper

- Fix hood lock by tightening securing screws.
- Verify proper functioning of hood lock opening control.
- Lubricate hood lock mechanism with proper grease.

REPLACEMENT OF HOOD OPENING CONTROL CABLE

CAUTION:

In case of breakage of hood opening control cable, it is possible to open the hood by pulling the nylon-made emergency cable ⑥, located in the passenger compartment inside.

- Cut the cable in proximity to hood lock device ② and loosen screw of sheath supporting bracket ④.
- Operating from vehicle inside, withdraw cable and sheath of hood opening control lever ⑤.
- Insert the new cable with sheath and secure it to hood opening control lever.

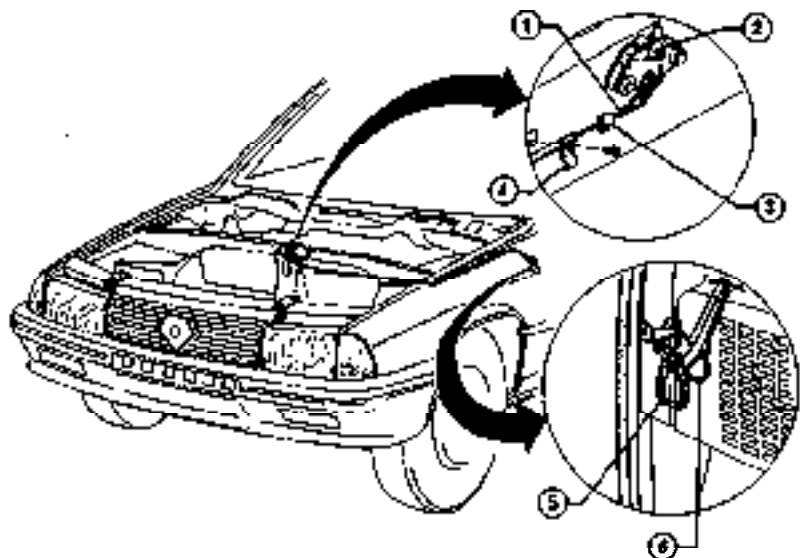

1 Cable

2 Hood lock device

3 Cable retaining ring

4 Bracket

5 Hood opening control

6 Nylon-made emergency cable

HOODS

4. Operating from engine compartment inside, insert cable ① into eyelet of hood lock ② and secure cable end to cable retaining ring ③.
5. Verify functioning of hood opening control.

6. If necessary, adjust sheath position by operating on special bracket ④.

CAUTION:

- Lubricate the cable with suitable

oil letting it slide into sheath. Do not bend excessively cable sheath in engine compartment in order to prevent opening stress increase.

BACKDOOR

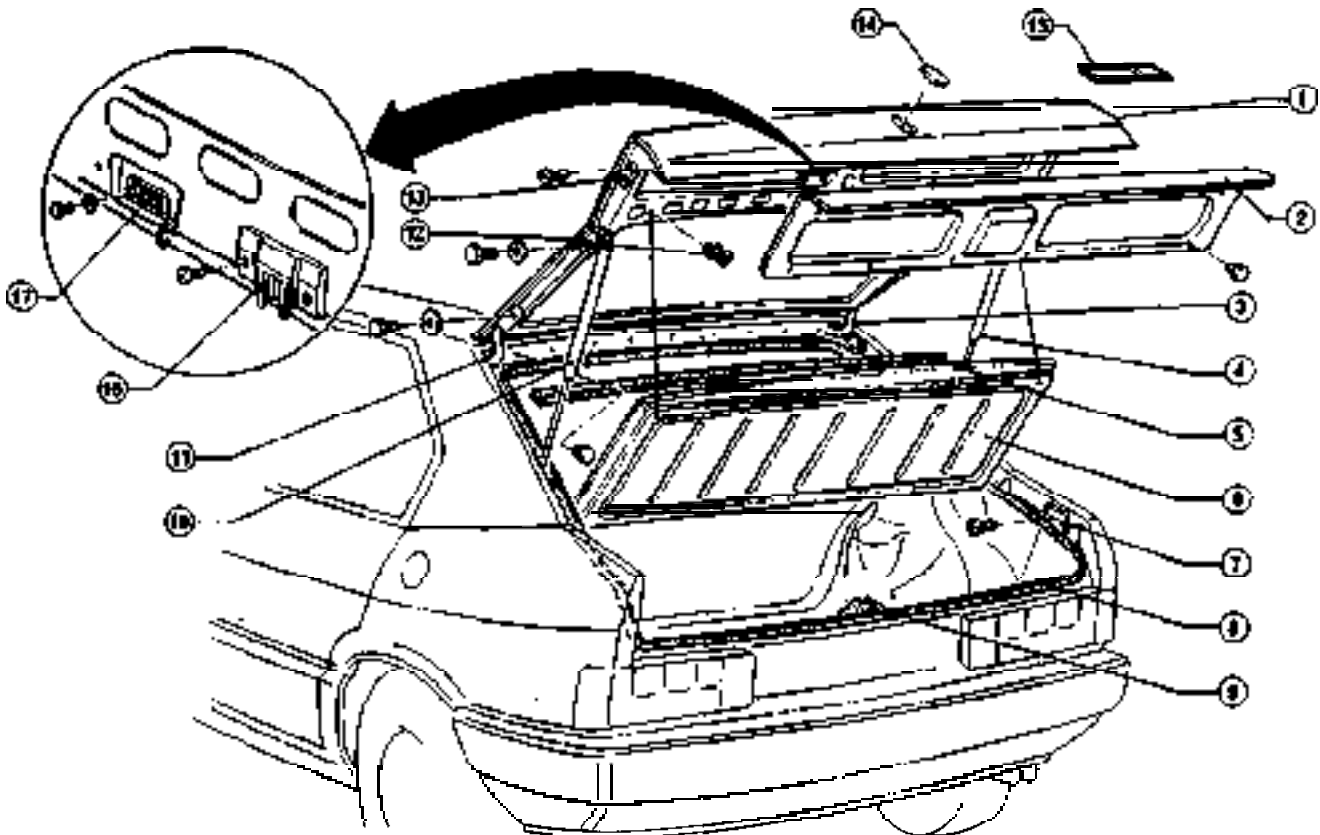

- 1 Backdoor
- 2 Backdoor trim
- 3 Hinge
- 4 Shock absorber
- 6 Seal
- 6 Movable shelf

- 7 Vibration-damper striker
- 8 Seal
- 9 Backdoor lock device
- 10 Shock absorber
- 11 Hinge
- 12 Support

- 13 Vibration damper striker
- 14 Badge
- 16 Label
- 16 Electric contacts
- 17 Backdoor striker

REMOVAL AND INSTALLATION

Before removal or installation, proceed as follows:

- Place a cloth or other padding on backdoor corners in order to avoid damaging or scratching vehicle body.

- Provide a support for backdoor to be used on removal from shock absorbers.
- Release the two cables supporting shelf under rear window.

For removal and installation of backdoor, two operators are required.

With reference to exploded view above proceed as follows:

1. By means of a screwdriver drill, remove the two rings securing rods of shock absorbers ④ and ⑩ and withdraw rods from their seat.

REPLACEMENT OF BACKDOOR OPENING CONTROL CABLE

1. Cut cable ① in proximity to backdoor lock device ② and loosen screw of bracket ④ sheath securing.

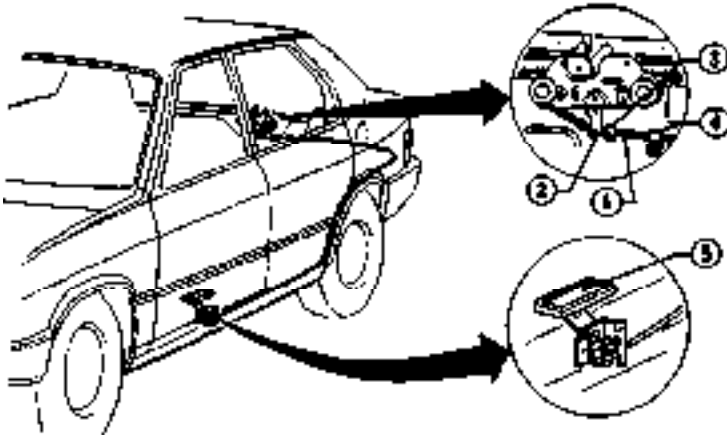

- 1 Cable
2 Backdoor lock device
3 Cable retaining ring

- 4 Bracket
5 Backdoor opening control

2. Operating from vehicle inside, withdraw cable and sheath from backdoor opening control lever ⑤.
3. Insert new cable with sheath and secure it to backdoor opening control lever.
4. Operating from luggage room, insert cable ① into eyelet of backdoor lock device ② and secure cable end on cable retaining ring ③.
5. Verify proper functioning of backdoor opening control.
6. If necessary, adjust sheath position operating on special bracket ④.

CAUTION:

- Lubricate the cable with proper oil letting it slide into sheath.
- Do not bend excessively cable sheath in the luggage room, in order to prevent opening stress increase.

TRIM

ROOF TRIM

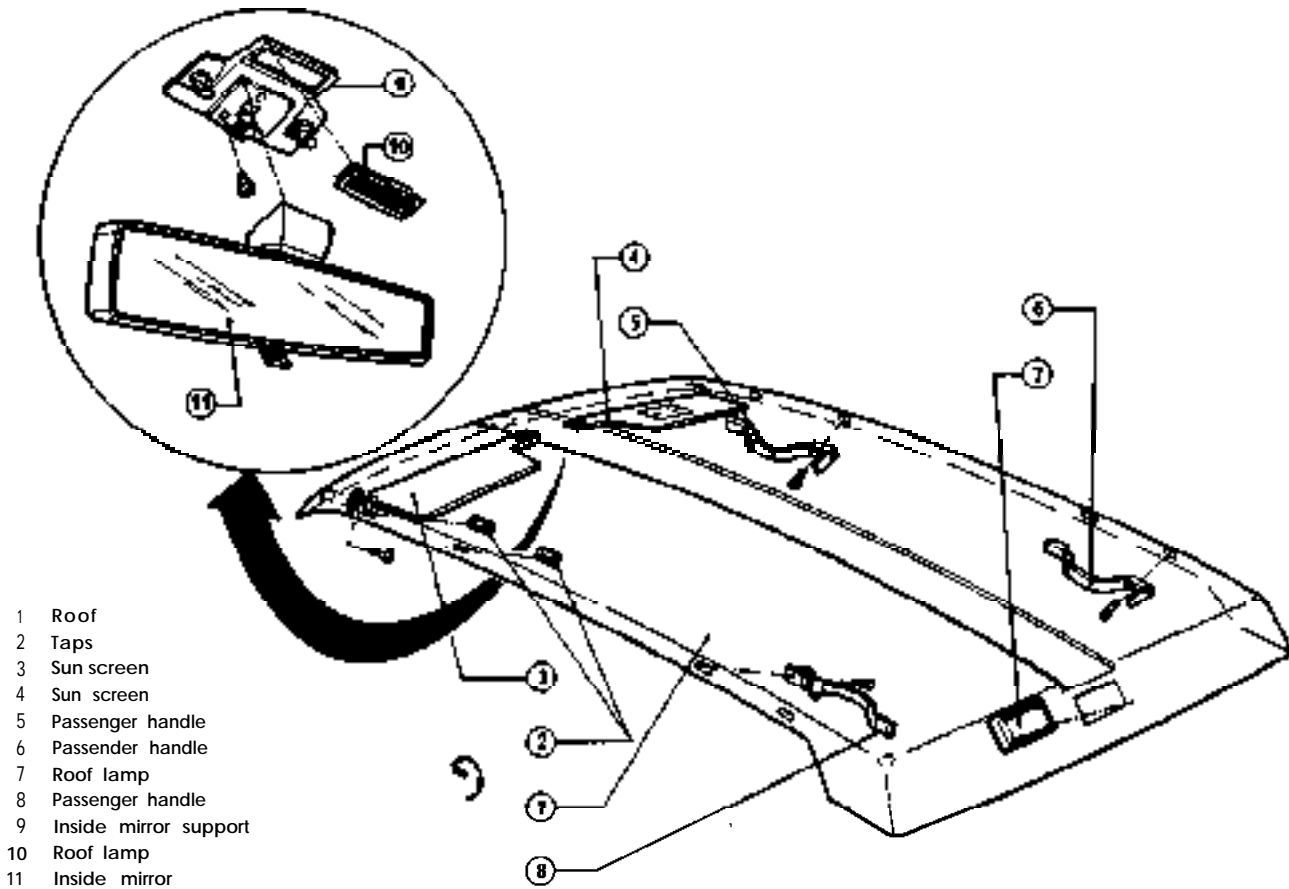

- 1 Roof
- 2 Taps
- 3 Sun screen
- 4 Sun screen
- 5 Passenger handle
- 6 Passenger handle
- 7 Roof lamp
- 8 Passenger handle
- 9 Inside mirror support
- 10 Roof lamp
- 11 Inside mirror

REMOVAL AND INSTALLATION

Be careful not to stain roof.

With reference to exploded view above proceed as follows:

1. Open protection of screws securing passenger handles (5), (6) and (8) to roof panel, unscrew them and remove handles,



2. By means of proper tool, remove taps (2).
 3. Disconnect harness and remove roof lamps (7) and (10).
 4. Remove inside mirror (11) in order to gain access to the three

screws securing mirror support (9) to roof panel and remove it.

5. Remove sun screens (3) and (4).

6. Remove weatherstrip of doors and of backdoor in contact with roof; move upper part of front pillar trim.

7. Remove roof trim (1) and withdraw it from backdoor compartment.

8. For installation, reverse order of removal.

CAUTION:

For installation, it is recommended to position roof trim starting from rear side and then use a cord to reposition windshield seal in its place (see: Group 75 - Windshield - Installation).

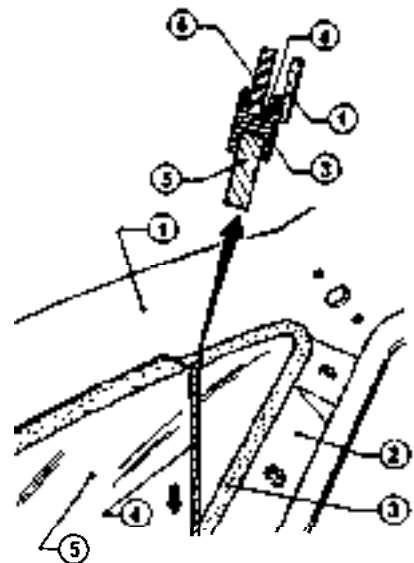

- 1 Roof trim
- 2 Front right pillar
- 3 Windshield seal
- 4 Cord
- 5 Windshield
- 6 Body

INTERNAL TRIMMING

FLOOR TRIM

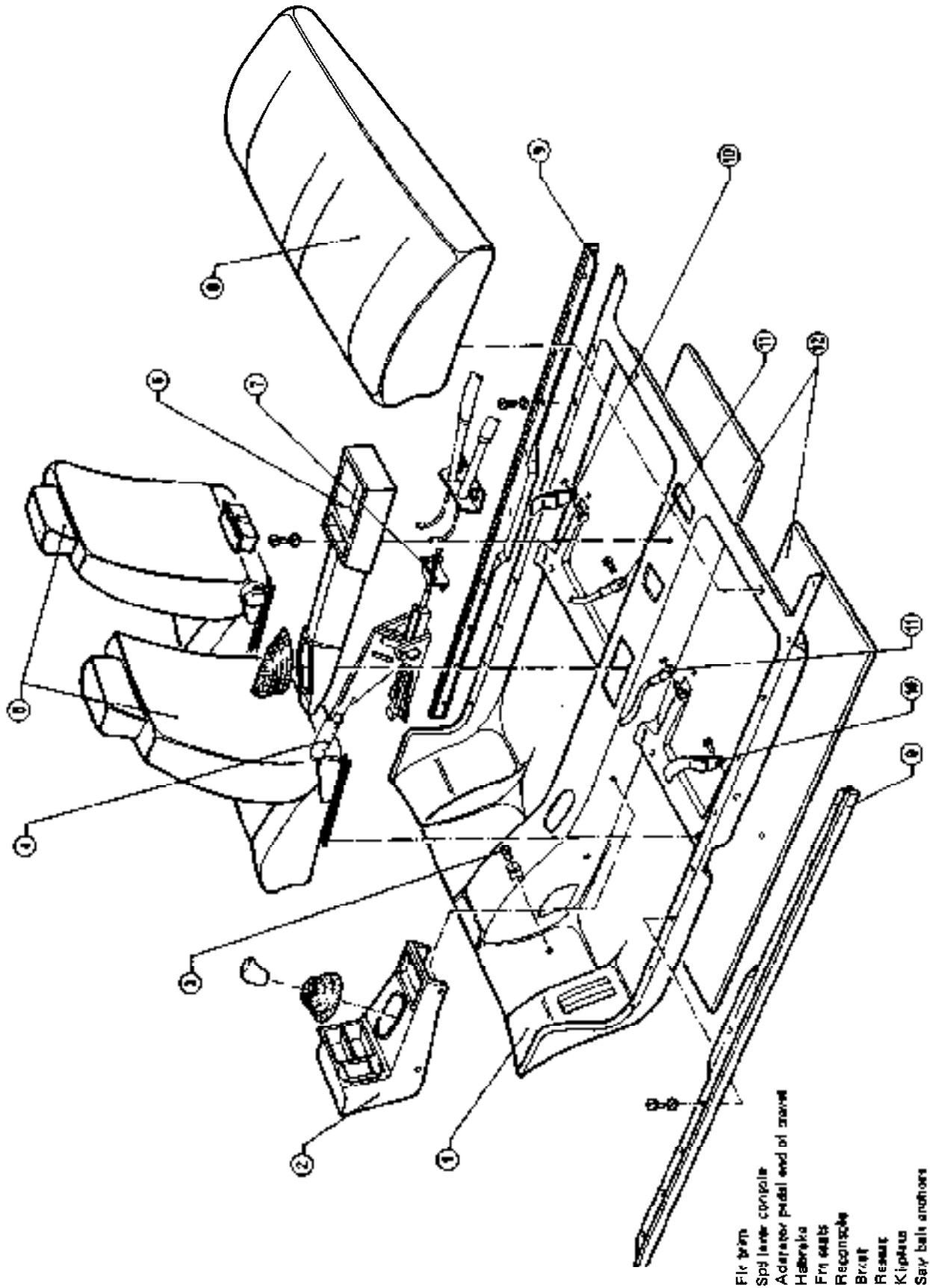

REMOVAL AND INSTALLATION

With reference to exploded view above proceed as follows:

1. Remove rear seat (8), front seats (5), rear console (6), speed level console (2) and safety belt anchors (10) and (11) (see the relevant paragraphs).
2. Unscrew the fourteen screws securing kick plate (9) to body and remove them.
3. By means of proper tool, withdraw plastic rivet securing to body the accelerator pedal end of travel (3); then remove it,

4. Remove seals of front door compartments in the part where they cover floor trim and remove the adhesive tape strips securing trim to body.

5. Unscrew nut and lock nut of parking brake (4) adjustment fork and withdraw the two cables from bracket (7).



6. Remove floor trim by withdrawing it from parking brake and, if necessary, remove soundproofing

material trim (12).

7. install floor trim by reversing order of removal. After installing handbrake cables, adjust it by following procedures described in Group 00 - Maintenance of Mechanic Components and Body.

CENTRAL PILLAR TRIM AND FRONT SAFETY BELTS

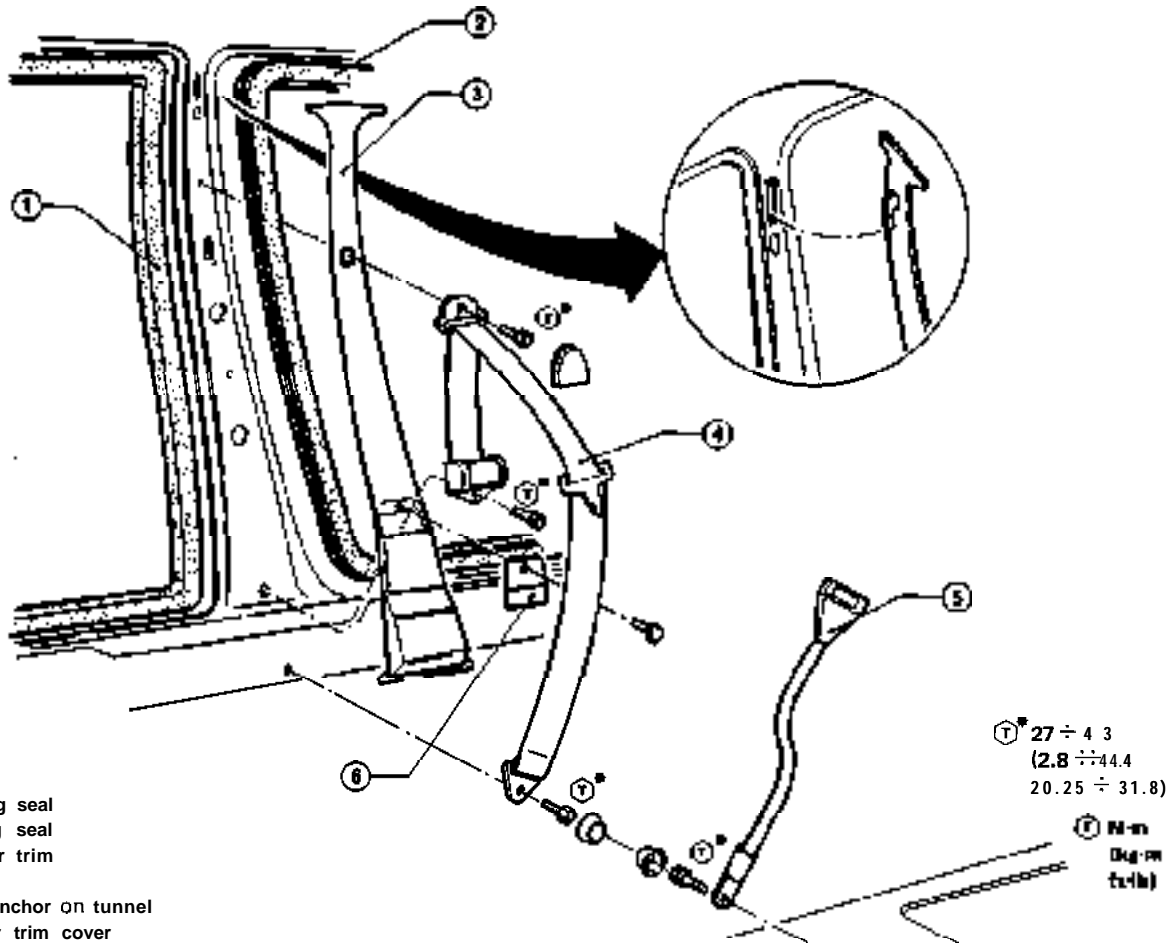

- 1 Door opening seal
- 2 Door opening seal
- 3 Central pillar trim
- 4 Safety belt
- 5 Safety belt anchor on tunnel
- 6 Central pillar trim cover

REMOVAL AND INSTALLATION

With reference to exploded view above, proceed as follows:

1. Move front seat completely forward.
2. Remove door opening seals (1)

and (2) in the part where they cover central pillar trim (1).

3. Lift protection of screw securing safety belt (4) support, unscrew it and remove the support.

4. After removing protection, unscrew the screw securing safety belt (4) anchor bracket to body.

INTERNAL TRIMMING

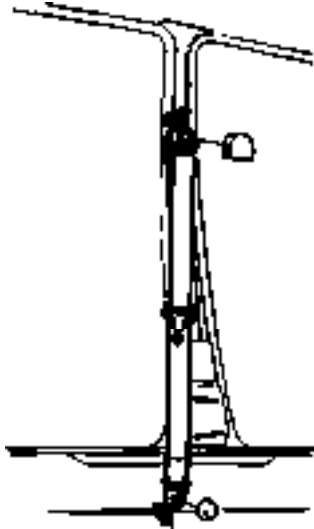

5. By means of proper tool, remove plastic rivet securing cover ⑥ to trim ③ and remove it.
6. Remove pillar trim ③ by lifting it.
7. Unscrew the screw securing safety belt ④ retractor and remove it.

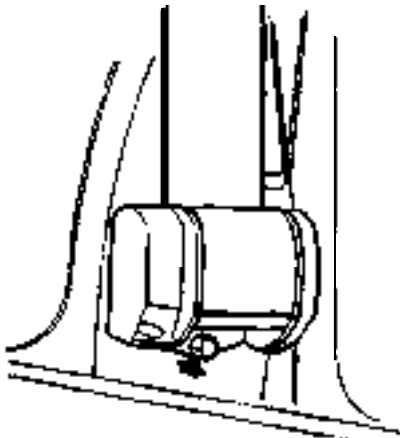

8. After removing protection, unscrew the screw securing safety belt anchor ⑤ on tunnel and remove it.

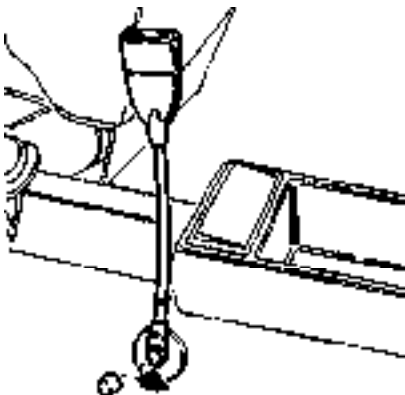

9. -Install safety belt and pillar trim by reversing order of removal. All the anchor safety belt screws, must be tightened to the prescribed torque.

Ⓣ : Tightening torque
 Safety belt anchor screws
 $27 \div 43 \text{ N}\cdot\text{m}$
 $(2,8 \div 4,4 \text{ kg}\cdot\text{m})$
 $20.25 \div 31.8 \text{ ft}\cdot\text{lb}$

CAUTION:

If the vehicle is collided or overturned, replace the entire belt assembly regardless of nature of accident.

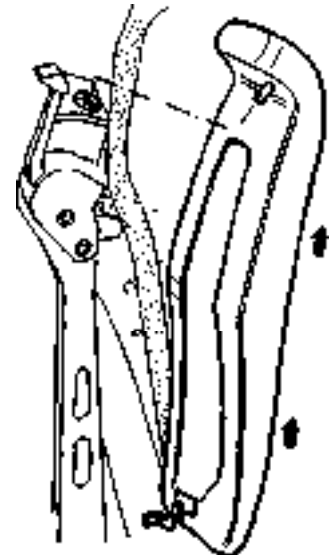
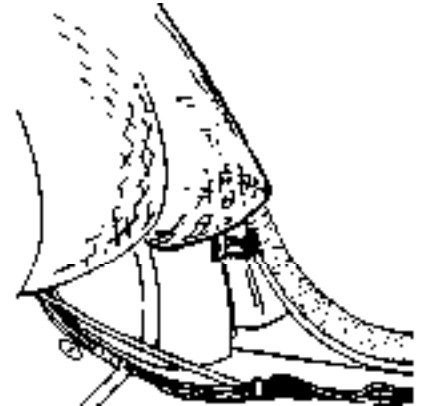

FIXED PART TRIM OF SHELF UNDER REAR WINDOW

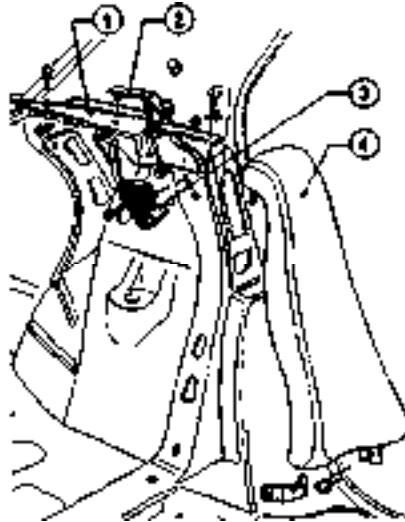

- 1 Fixed part trim of shelf under rear window
- 2 Movable shelf hinge
- 3 Seat back clamping device
- 4 Seat back fixed part

REMOVAL AND INSTALLATION

With reference to the exploded view above proceed as follows:

1. Remove movable shelf under rear window.
2. Unscrew screw securing seat back fixed part ④ to body, lift seat back and remove it.

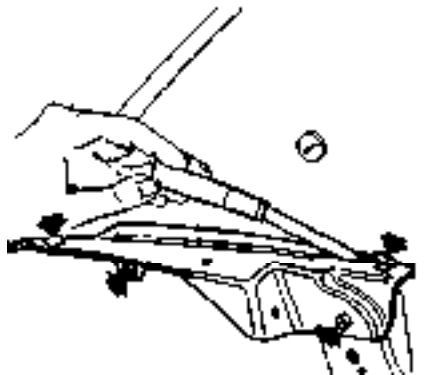

6. Install trim by reversing order of removal.

REAR PILLAR TRIM

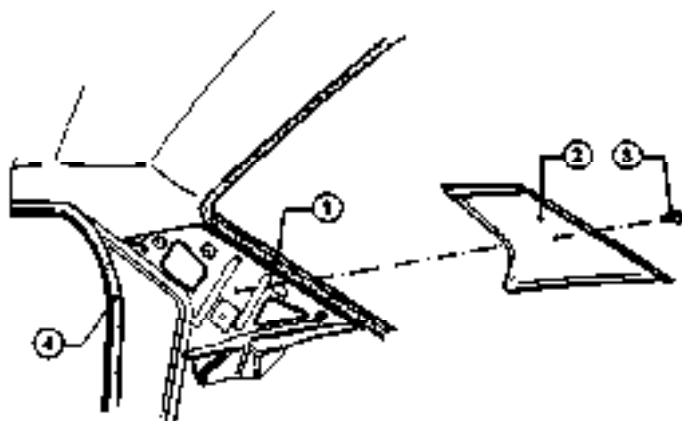

- 1 Back door seal
- 2 Rear pillar trim
- 3 Plastic cap
- 4 Door opening seal

REMOVAL AND INSTALLATION

1. Remove door opening seal (4) in the part where it covers trim (2).
2. Detach plastic cap (3) and remove pillar trim (2).
3. Install trim by reversing order of removal.

LUGGAGE ROOM SIDE TRIM

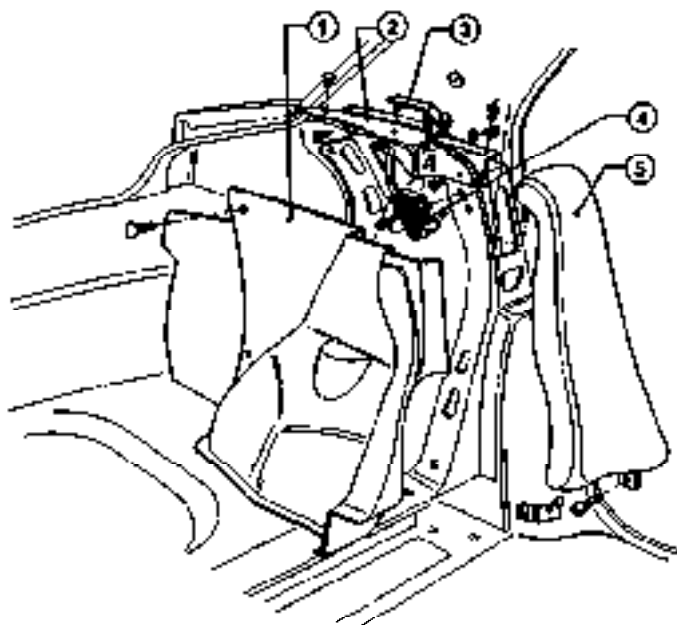

- 1 Luggage room side trim
- 2 Fixed part trim of shelf under rear window
- 3 Movable shelf hinge
- 4 Seat back clamping device
- 5 Seat back fixed part

REMOVAL AND INSTALLATION

1. Remove seat back clamping device (4), seat back fixed part (5) and trim of fixed part shelf under rear window (2) (see: Trim of fixed part shelf under rear window).
2. By means of proper tool, remove plastic rivets securing side trim to body, then remove it.
3. Install side trim by reversing order of removal.

INTERNAL TRIMMING

REMOVAL AND INSTALLATION

Take care not to stain seat and seat back upholstery.

With reference to the above exploded view proceed as follows:

1. Move seat completely forward and unscrew the two rear screws securing guides (9) and (11) to floor.

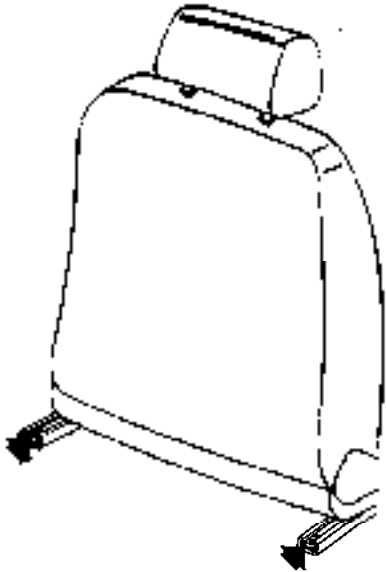

2. Move seat completely backward and unscrew the two front screws securing guides (9) and (11) to floor.

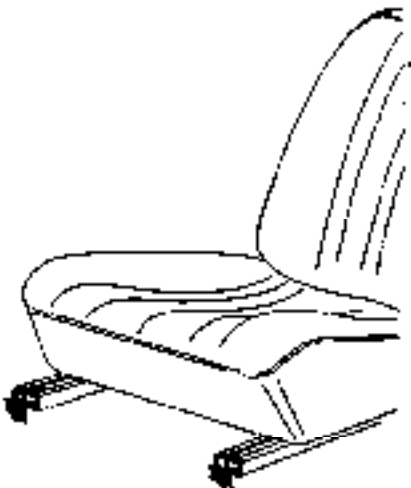

3. Remove seat together with guides, from car.

4. If necessary, remove guides (9) and (11) from seat.

(1) By means of proper tool, release the seat turnover control lever (10) from guides.

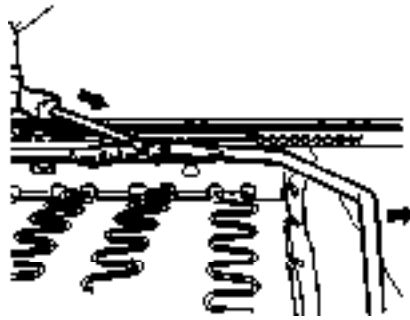

(2) Remove guides by unscrewing the four securing screws to seat (8).

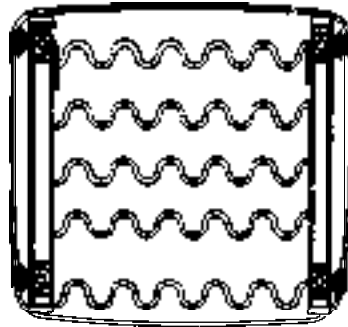

(3) Install guides and control lever by reversing order of removal and tightening screws to the prescribed torque.

⊕ : Tightening torque

Screws securing guides to seat

$17 \div 20 \text{ N}\cdot\text{m}$

$(1.8 \div 2.1 \text{ kg}\cdot\text{m})$

$13.0 \div 15.2 \text{ ft}\cdot\text{lb}$

5. If necessary, remove seat back adjustment device (12), hinge (5), and seat back (3).

(1) Lift cover (15) of seat back adjustment device (12).

(2) Keeping knob (14) still, by means of proper plier, rotate counterclockwise the plate securing knob; then remove it.

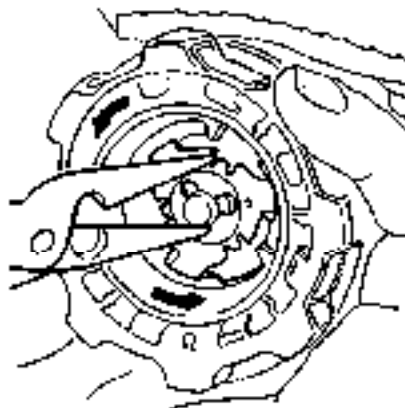

(3) Remove plastic trims (7) and (13).

(4) Unscrew the four screws securing to seat (8) the seat back adjustment device (12) and hinge (5); then remove seatback (3).

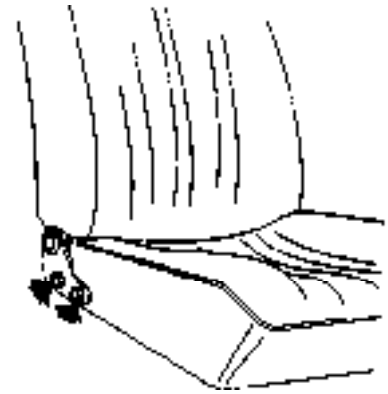

(5) Remove the four screws securing trim (4) to seat back (3) upholstery.

(6) Lift clamps securing seat back upholstery, turn it inside out and lift it until protections (6) and (16) of seat back adjustment device (12) securing screws and of hinge (5) are uncovered.



(7) Remove plastic protections (6) and (16) and unscrew the four screws securing to seatback the seatback adjustment device and hinge; then remove them.

INTERNAL TRIMMING

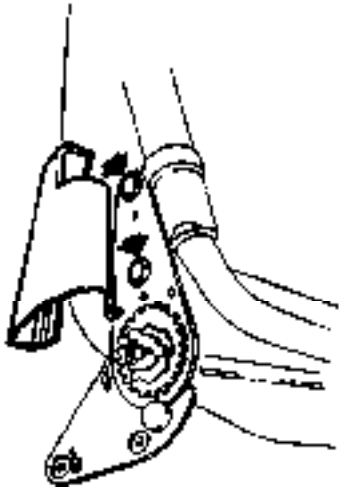

(8) For installment reverse order of removal. Tighten the screws of seatback adjustment device and of hinge to the prescribed torque.

T : Tightening torque
Securing screws of seat back adjustment device and of hinge
 $17 \div 29 \text{ N}\cdot\text{m}$
 $(1.8 \div 3 \text{ kg}\cdot\text{m})$
 $13 \div 21.7 \text{ ft}\cdot\text{lb}$

6. If necessary, remove headrest by operating on knurled part as shown in figure.

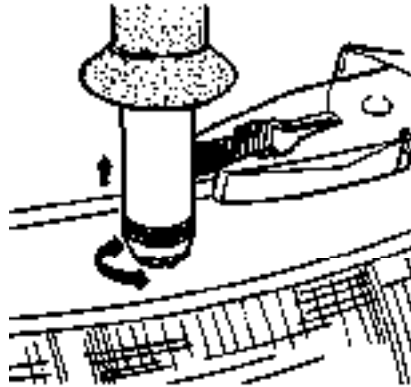

7. Install seat on car by reversing order of removal and tightening screws securing seat guides to floor, to the prescribed torque.

T : Tightening torque
Screws securing seat guides to floor
 $10 \div 11 \text{ N}\cdot\text{m}$
 $(1.1 \div 1.2 \text{ kg}\cdot\text{m})$
 $8 \div 8.7 \text{ ft}\cdot\text{lb}$

REAR SEATS

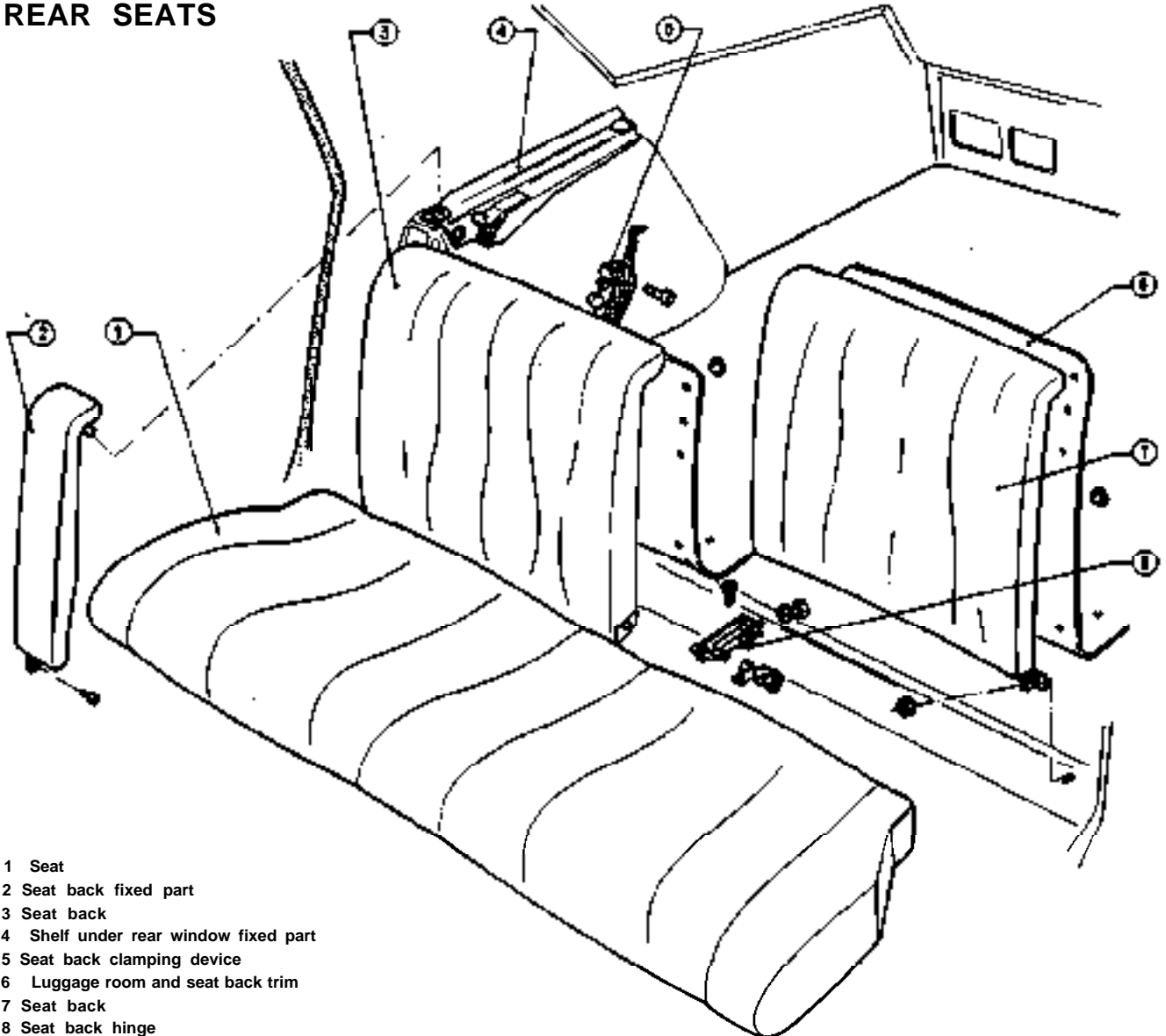

- 1 Seat
- 2 Seat back fixed part
- 3 Seat back
- 4 Shelf under rear window fixed part
- 5 Seat back clamping device
- 6 Luggage room and seat back trim
- 7 Seat back
- 8 Seat back hinge

INTERNAL TRIMMING

REMOVAL AND INSTALLATION

Take care not to stain seat and seat back upholstery.

1. Lift and remove seat.
2. Unscrew the screw securing to body ③ the seat back fixed part ① then lift seat back and remove it.

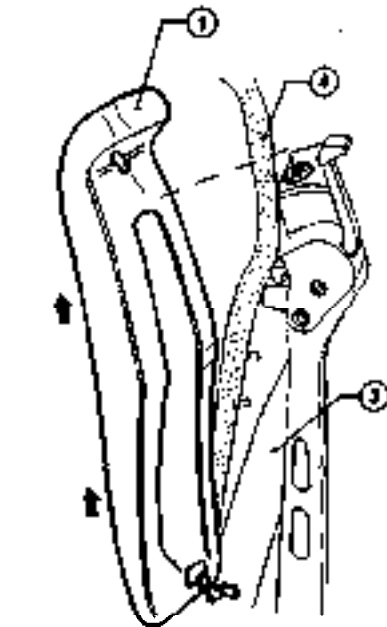
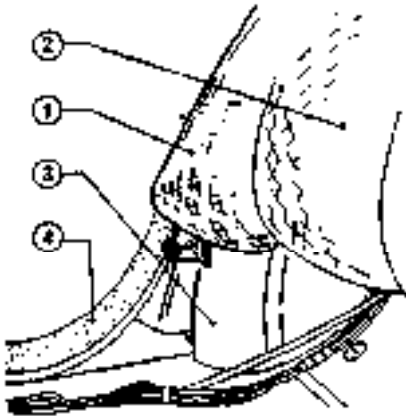

- 1 Seat back fixed part
- 2 Seat back
- 3 Body
- 4 Door compartment seal

3. By means of proper tool, withdraw plastic rivets securing luggage room upholstery to seat back.

4. Unscrew nut securing seat back ① to body ④ and remove it.

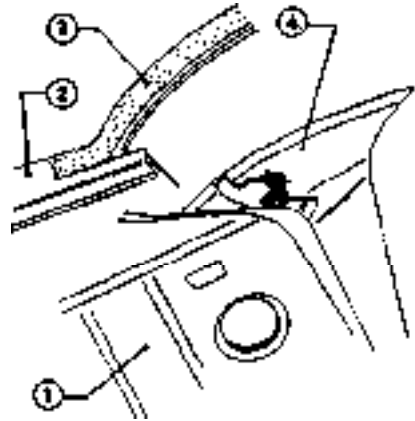

- 1 Seat back
- 2 Kick plate
- 3 Door compartment seal
- 4 Body

5. Carry out same procedure for removal of the other seat back.
6. Install seat backs and seat, by reversing order of removal.

CONSOLES

REAR CONSOLE

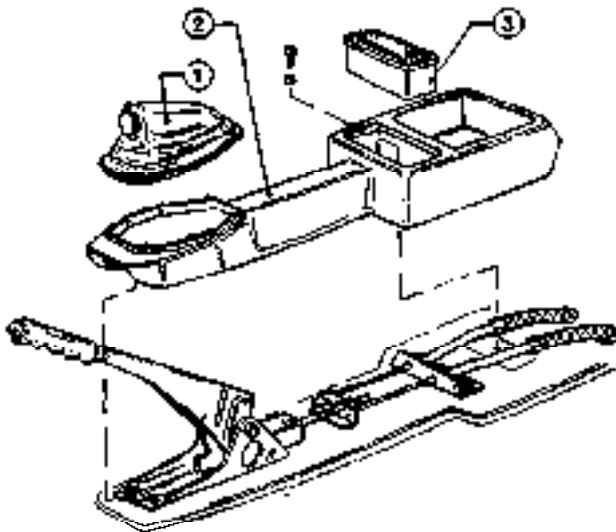

- 1 Rubber bellows
- 2 Console
- 3 Ashtray

REMOVAL AND INSTALLATION

1. Remove rubber bellows located on parking brake.
2. Remove ashtray, which is pressure secured.
3. Unscrew the screw securing console and remove it by moving it first forward in order to withdraw it from clamp located on floor tunnel.

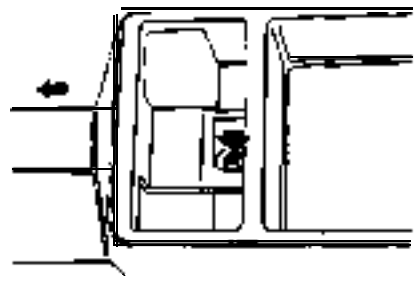

4. Install console by reversing order of removal.

CENTRAL CONSOLE

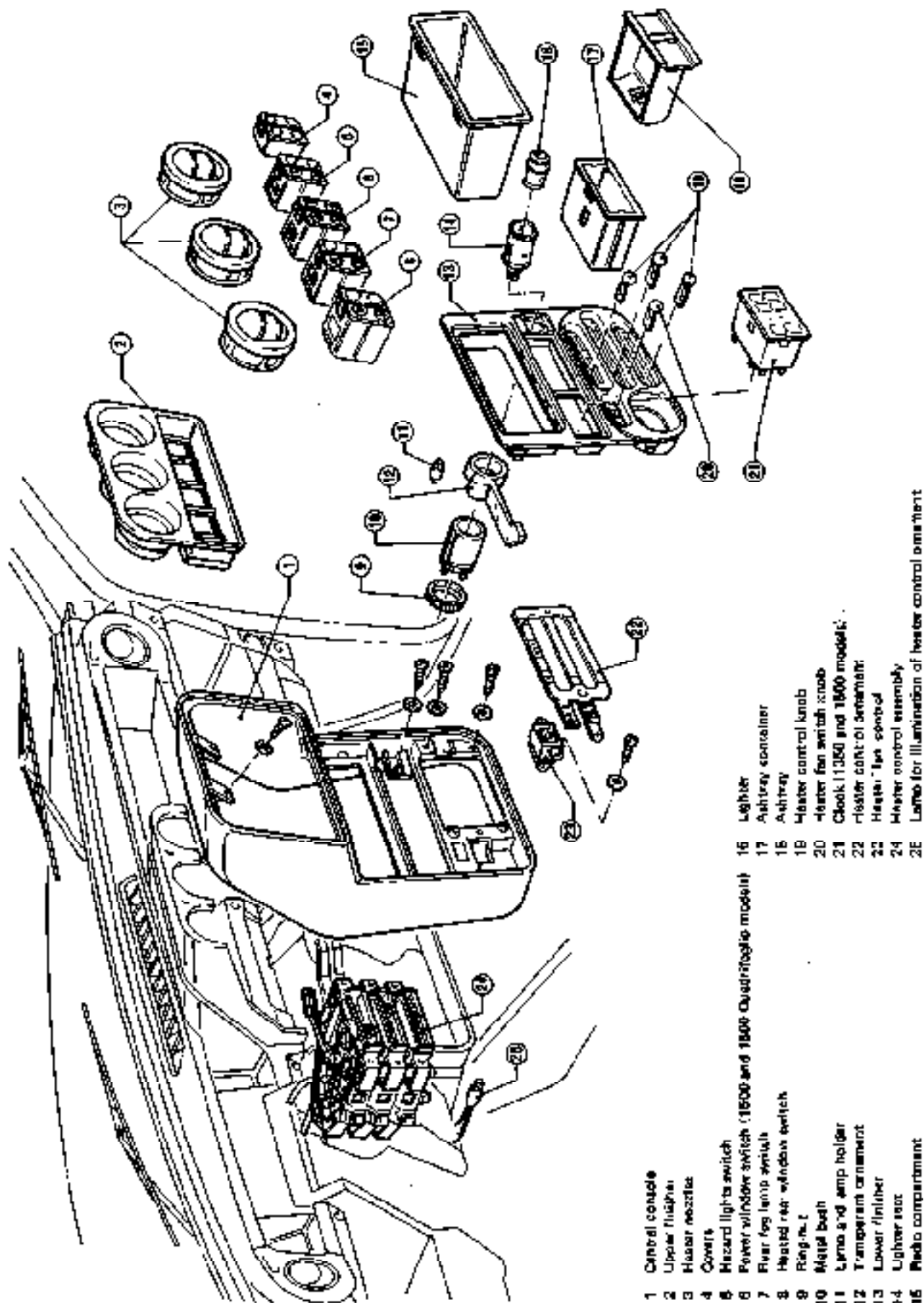

- 1 Central console
- 2 Upper finisher
- 3 Heater nozzles
- 4 Covers
- 5 Hazard lights switch
- 6 Power window switch (1500 and 1500 Quadricycle models)
- 7 Rear fog lamp switch
- 8 Heated rear window switch
- 9 Ring nut
- 10 Metal bush
- 11 Lamp and amp holder
- 12 Transparent ornament
- 13 Lower finisher
- 14 Lighter socket
- 15 Radio compartment
- 16 Lighter
- 17 Ashtray concealer
- 18 Ashtray
- 19 Heater control knob
- 20 Heater fan switch knob
- 21 Clock (1350 and 1500 models)
- 22 Heater control ornament
- 23 Heater fan speed
- 24 Heater control assembly
- 25 Lamp for illumination of heater control ornament

INTERNAL TRIMMING

REMOVAL AND INSTALLATION

CAUTION:

- Disconnect battery ground cable.
- Before removing the components fitted with harness, make sure that relevant connections have been disconnected.

With reference to exploded view above proceed as follows:

1. Remove by pulling, knobs ⑱ and ⑳ of heater control assembly.
2. Detach finisher ⑬ and disconnect harness of clock ㉑, lighter seat ⑭ and lamp ①.
3. Remove finisher ⑬.
4. If necessary, remove lighter seat ⑭ by unscrewing ring nut ⑨ and withdrawing bush ⑩ and ornament ⑫.

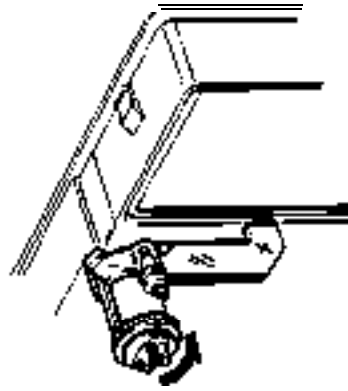

5. By means of proper tool, remove finisher ②.

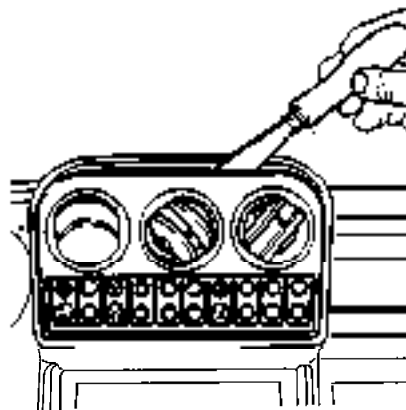

6. Disconnect harness of switches ⑤, ⑥, ⑦ and ⑧; then remove finisher ②.

7. Unscrew the four screws securing heater control assembly ㉒ to console ①.

8. Remove the four screws securing console ① to dashboard.

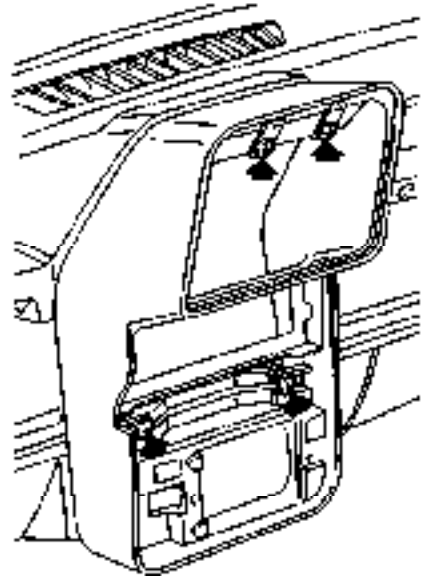

9. Remove console ① being careful during lamp ㉓ and harness removal.

10. Install console and its components, by reversing order of removal.

DASHBOARD

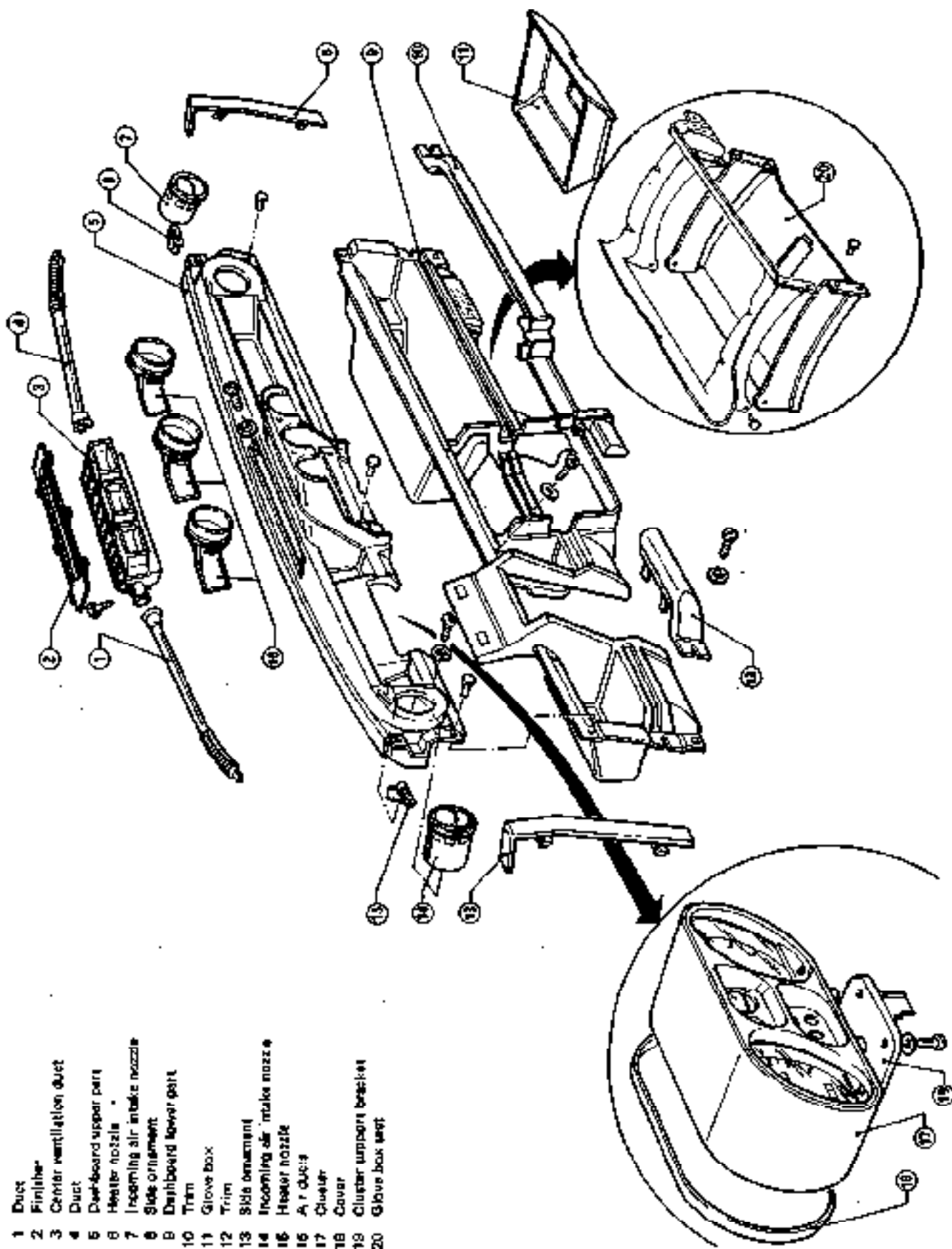

- 1 Duct
- 2 Finisher
- 3 Center ventilation duct
- 4 Duct
- 5 Dashboard upper part
- 6 Heater nozzle
- 7 Incoming air intake nozzle
- 8 Side ornament
- 9 Dashboard lower part
- 10 Trim
- 11 Glove box
- 12 Trim
- 13 Side ornament
- 14 Incoming air intake nozzle
- 15 Heater nozzle
- 16 Air ducts
- 17 Cluster
- 18 Cover
- 19 Cluster support bracket
- 20 Glove box seat

INTERNAL TRIMMING

REMOVAL AND INSTALLATION

CAUTION:

- Remove battery ground cable.
- Before removing the components fitted with harness, make sure that relevant connections have been disconnected.

With reference to exploded view above proceed as follows:

1. Remove central console (see: Central Console).
2. Remove steering wheel and column shell covers (see: Group 23 - Steering Wheel and Column).
3. Remove cluster ⑰.
- (1) Unscrew the four screws securing cluster ⑰ to support bracket@.

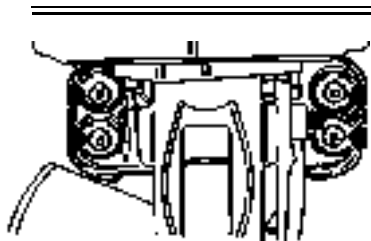

Low view

- (2) Open cover ⑱ pressure inserted, disconnect harness; then remove cluster ⑰.
4. Operating as per figure, remove spring securing center ventilation duct ③ control cable to heater control assembly.

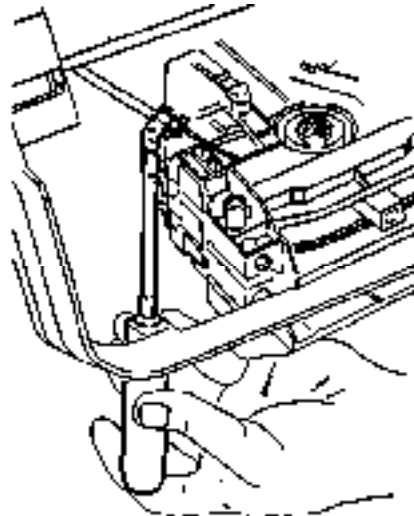

5. By means of proper tool, remove ornaments ⑧ and ⑬.

6. By means of proper tool, remove finisher ② of duct ③ and unscrew the two screws securing dashboard ⑤ to body.



7. Unscrew the seven screws securing dashboard ⑤ and ⑨ to body.

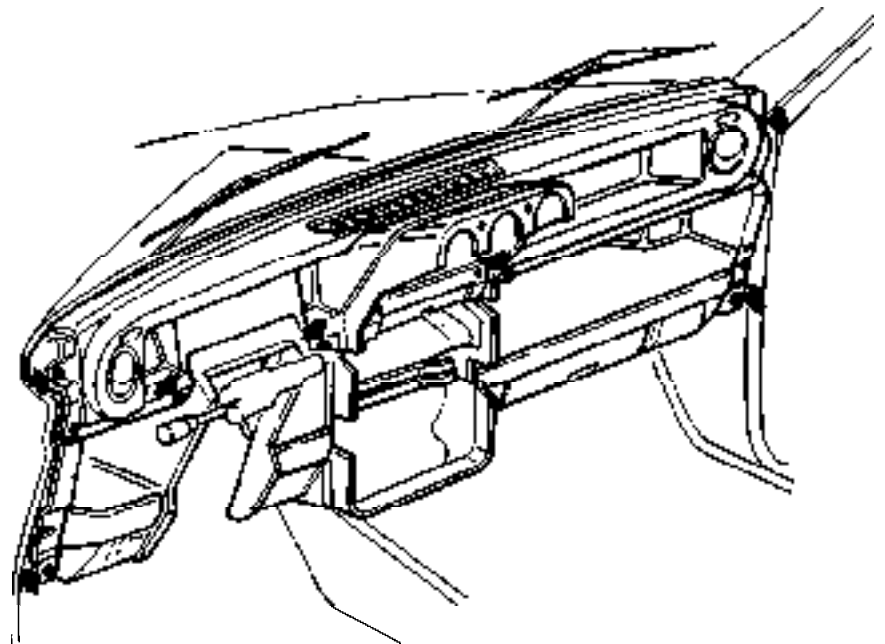

CAUTION:

To remove the whole dashboard, two operators are required.

8. Remove the whole dashboard ⑤ and ⑨.

9. If necessary, disassemble dashboard components ⑤ and ⑨.

- (1) By means of a drilling machine fitted with suitable drill, countersink the four rivets securing upper dashboard ⑤ to lower dashboard ⑨.

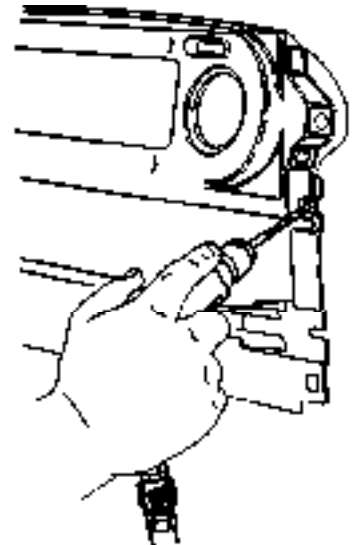

SERVICE DATA AND SPECIFICATIONS

TIGHTENING TORQUE

Unit	N-m	kg-m	ft-lb
Item			
CENTRAL PILLAR TRIM AND SAFETY BELTS			
Safety belt anchor screws	27 ÷ 43	2.8 ÷ 4.4	20.25 ÷ 31.8
FRONT SEATS			
Screws securing guides to seat	17 ÷ 20	1.8 ÷ 2.1	13 ÷ 15.2
Securing screws of seat back adjustment device and of hinge	17 ÷ 29	1.8 ÷ 3	13 ÷ 21.7
Screws securing seat guides to floor	10 ÷ 11	1.1 ÷ 1.2	8 ÷ 8.7

EXTERNAL TRIMMING



CONTENTS

FRONT BUMPER	75-2	G LASSES	75-7
REAR BUMPER	75-3	Windscreen	75-7
DRIP COVER MOLDING	75-4	Rear window	75-9
GRILLE	75-5	SPECIAL SERVICE TOOLS	75-11
COWL TOP COVER	75-6		



FRONT BUMPER.

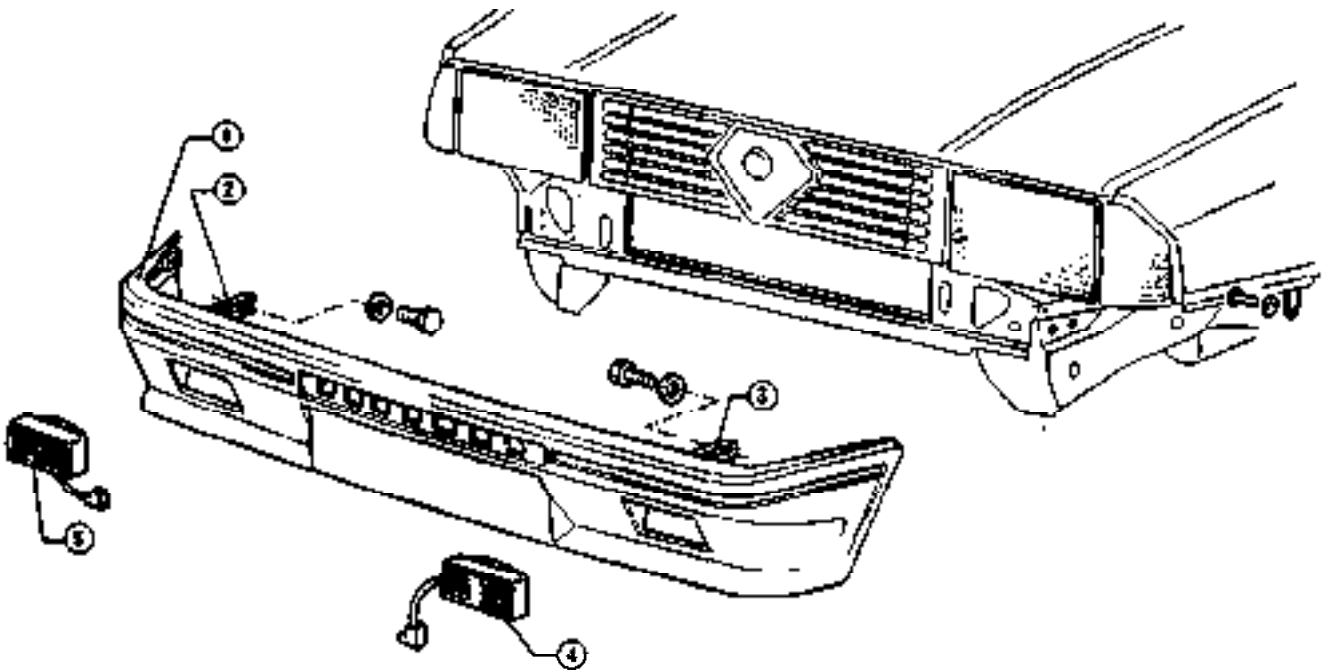

1 Bumper
2 Bracket
3 Bracket

4 Fog light
5 fog light

REMOVAL AND INSTALLATION

With reference to exploded view above proceed as follows:

1. If present, disconnect fog light (4) and (5) harness.
2. Operating from engine compartment inside, disconnect harness of the two electromagnetic horns, unscrew the nut securing each horn to bracket, and remove horns.

3. Unscrew the four screws securing brackets (2) and (5) to sills.

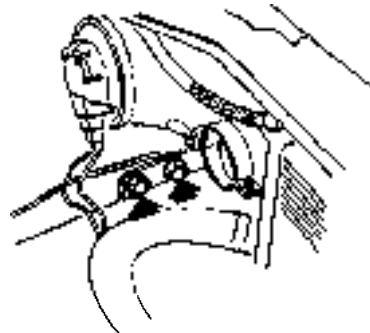
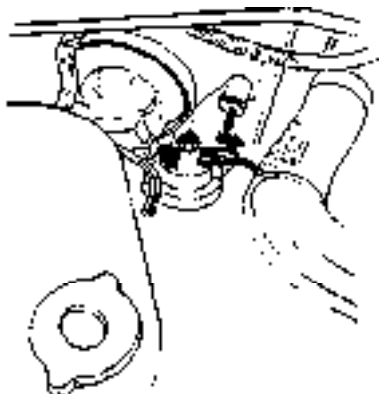

4. Unscrew the two screws securing bumper to fenders.

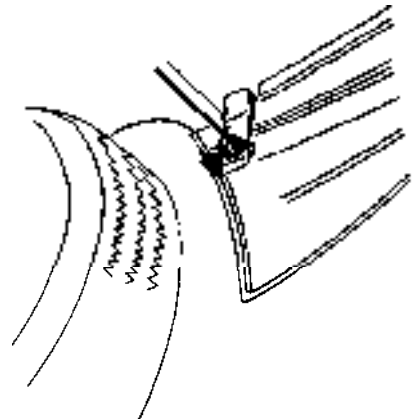

5. Remove bumper and, if necessary, disassemble fog lights.
6. Connect bumper to body by reversing order of removal.

REAR BUMPER

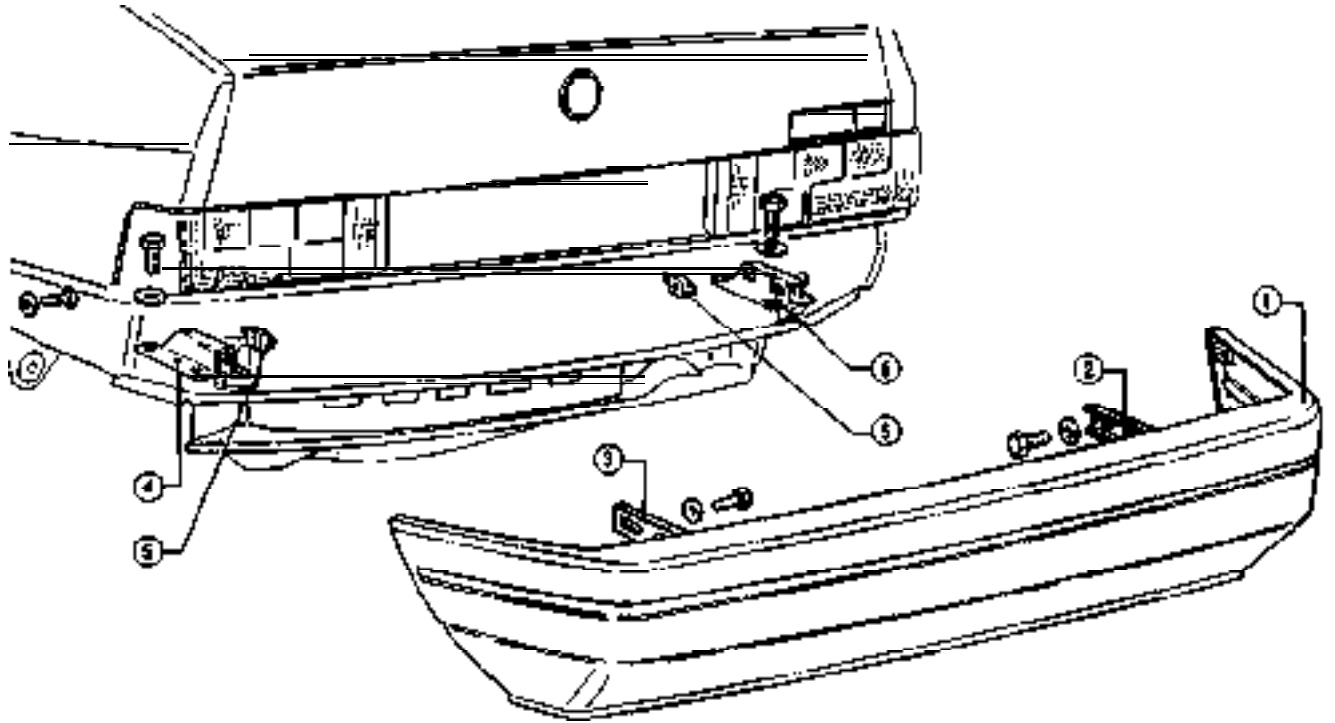

1 Bumper
2 Bracket
3 Bracket

4 Bracket
6 Nuts
6 Bracket

REMOVAL AND INSTALLATION

With reference to exploded view above proceed as follows:

1. Lift luggage room upholstery and rear trim.

2. Unscrew the four screws securing bumper brackets (2) and (3) to brackets (4) and (6).

3. Unscrew the two screws securing bumper (1) to body.

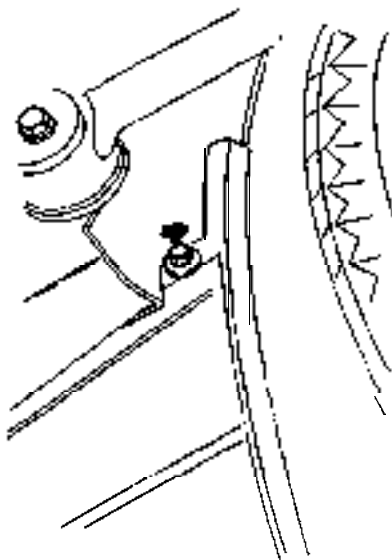
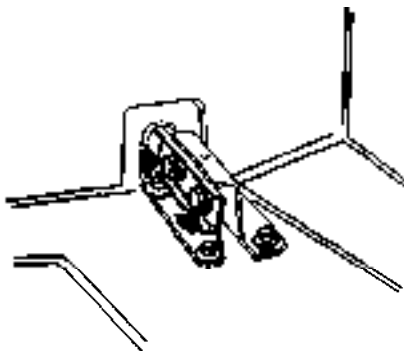

4. Remove bumper.

5. If necessary, unscrew the eight screws securing brackets (4) and (6) to rear floor.

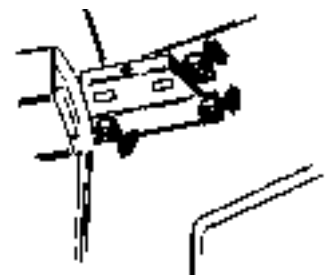

6. Install bumper, by reversing order of removal.

GRILLE

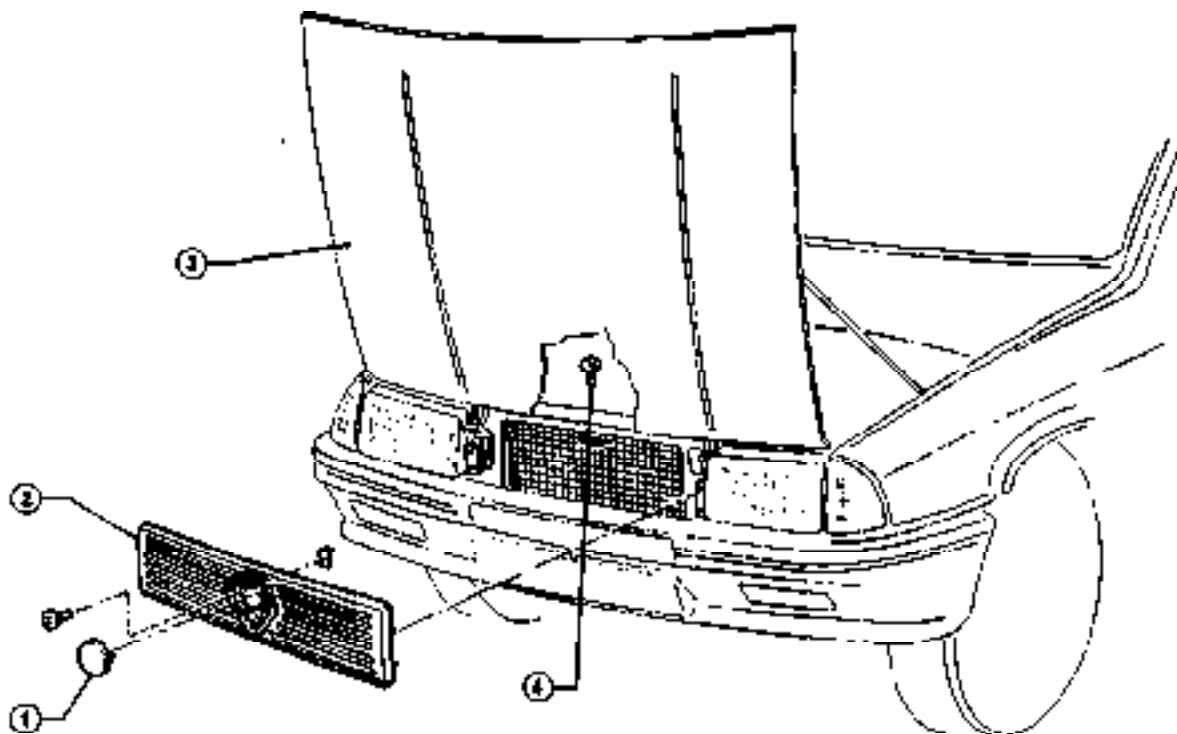

1 Badge
2 Grille

3 Hood
4 Screw

REMOVAL AND INSTALLATION

With reference to exploded view above proceed as follows:

1. Open hood completely removing it from stay.
2. By means of a magnetic screwdriver, unscrew screw (4) securing grille (2) to body.
3. Remove grille, by means of suitable wooden tool.

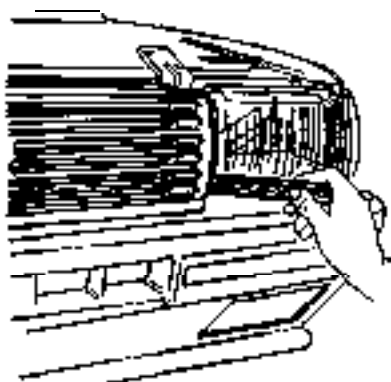

4. Install grille by reversing order of removal.

CAUTION:

- Be careful not to exert excessive force during operations, as grille is made of plastic.
 - Take care to keep oil away from grille.
-

COWL TOP COVER

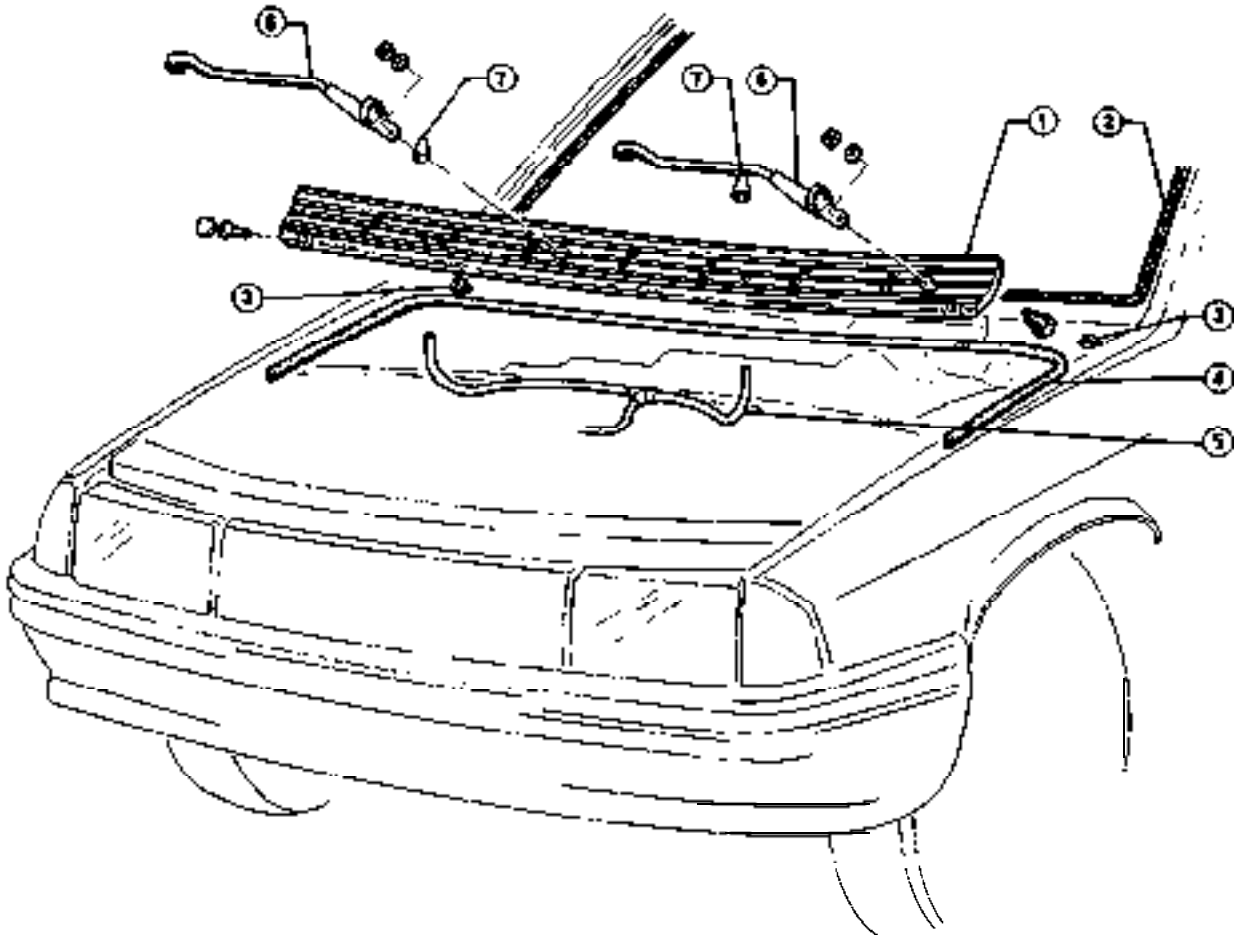

1 cowl top cover
 2 Windscreen seal
 3 Plastic nut screw
 4 Seal rubber

5 Windscreen washer pipings
 6 Windscreen wiper arms
 7 Sprayers

With reference to exploded view above proceed as follows:

1. Open hood and remove seal (4).
2. Lift protections of nuts securing wiper arms (6), unscrew the relevant screws; then remove wiper arms.
3. By means of proper tool, remove the five springs securing cowl top cover (1) to body.

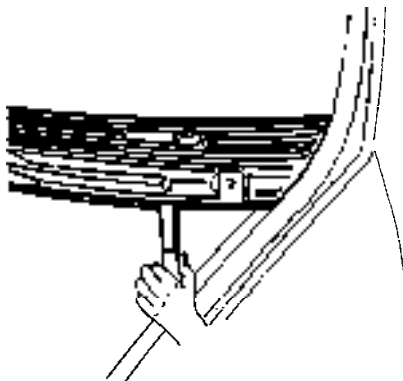

4. Unscrew the two screws, protected by a cover, securing cowl top cover (1) to body; then lift cowl.
5. Disconnect windscreen washer pipings (5) separating them from sprayers (7) which are pressure inserted into cowl top cover, then remove cowl top cover.
6. Install cowl top cover by reversing order of removal.

EXTERNAL TRIMMING

REMOVAL

With reference to exploded view above proceed as follows:

1. Remove wiper arms (7) and move cowl top cover (6) forward (see: Cowl-Top Cover).
2. Operating from vehicle inside,

remove, by means of proper tool ornament (5).

3. Remove door opening seal (4) in the part where it covers pillar trim (3).
4. By means of proper tool,

remove pillar trim (3), then remove it. 5. Operating as per the following figure, set end of tool A.9.0051 out of every 10 cm (4 in), starting from centre of windscreen upper rim; between body and windscreen seat.

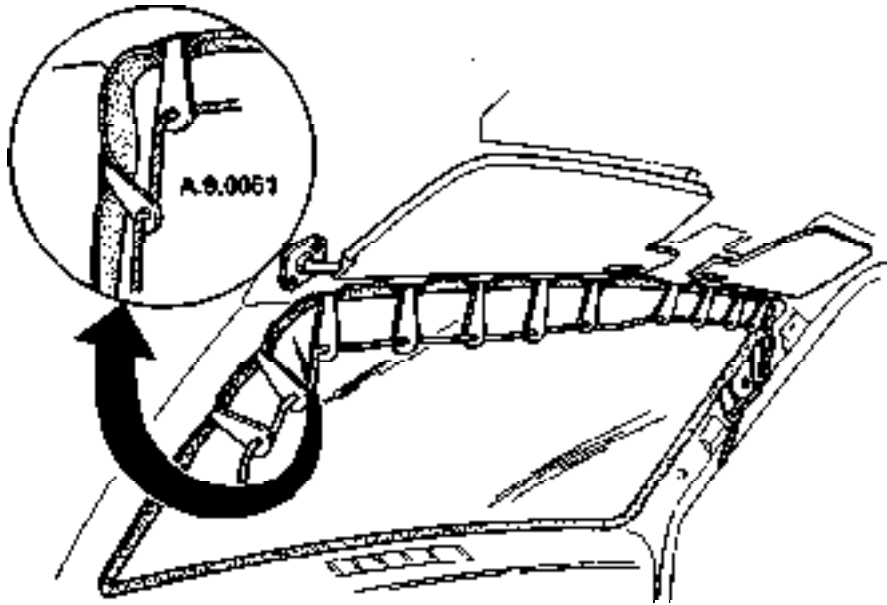

6. Carefully pull upper part of windscreen, remove it from body, then remove it completely.

INSTALLATION

For installation, two operators are required.

CAUTION:

By means of silicone, lubricate rim of windscreen weatherstrip in order to allow an easy insertion of weatherstrip on body.

1. Into weatherstrip rim (2), insert two cords (A and B) arranged as per figure in order to allow repositioning of weatherstrip (2) on body.

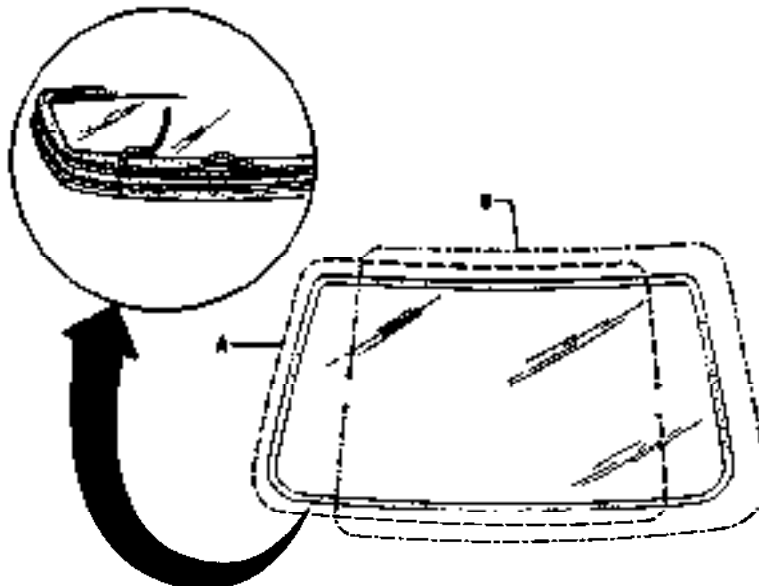

EXTERNAL TRIMMING

2. Rest windscreen on lower side of its seat into body and verify it is properly centered with weatherstrip ② mounted on lower side, only.

3. Slowly pull first cord starting from upper rim and follow positioning of weatherstrip rim by slightly tapping, with the hand, on windscreen from outside.

4. Repeat same operation with second cord until complete installation of windscreen.

5. Carry out installation of pillar trim, of door compartment seal and of ornament, by reversing order of removal.

6. Install cowl top cover and wiper arms.

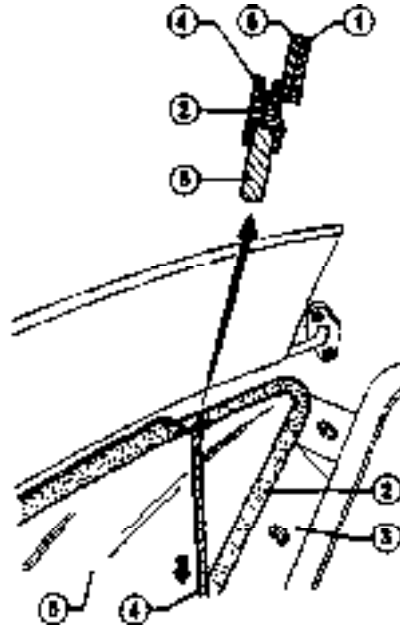

- 1 Roof trim
- 2 Windscreen seal weatherstrip
- 3 Right Cord front pillar

16 Windscreen Body

REAR WINDOW

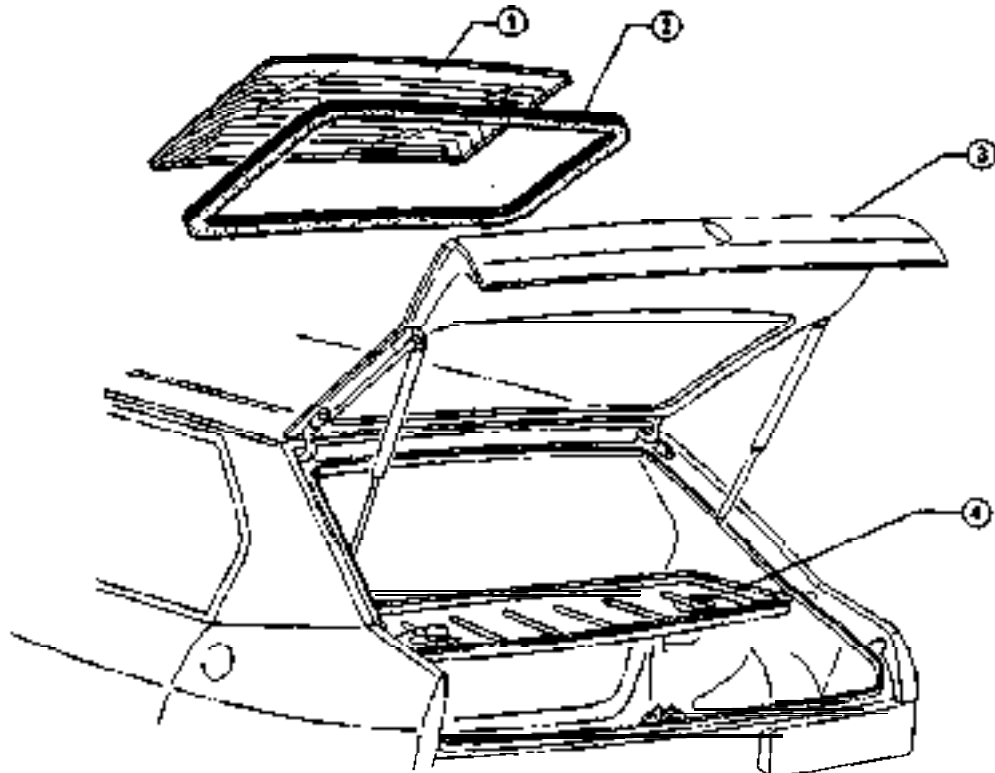

- 1 Rear window
- 2 Rear window weatherstrip

- 3 Backdoor
- 4 Movable shelf

EXTERNAL TRIMMING

REMOVAL

With reference to exploded view above proceed as follows:

1. Open back door and release the two cables supporting shelf (4)

under rear window.

2. Disconnect electric cables of heated rear window.

3. Operating as per the following figure, set end of tool A-9.0051 out

of every 10 cm (4 in), starting from center of rear window upper rim, between back door (3) sheet and rear window weatherstrip seal (2).

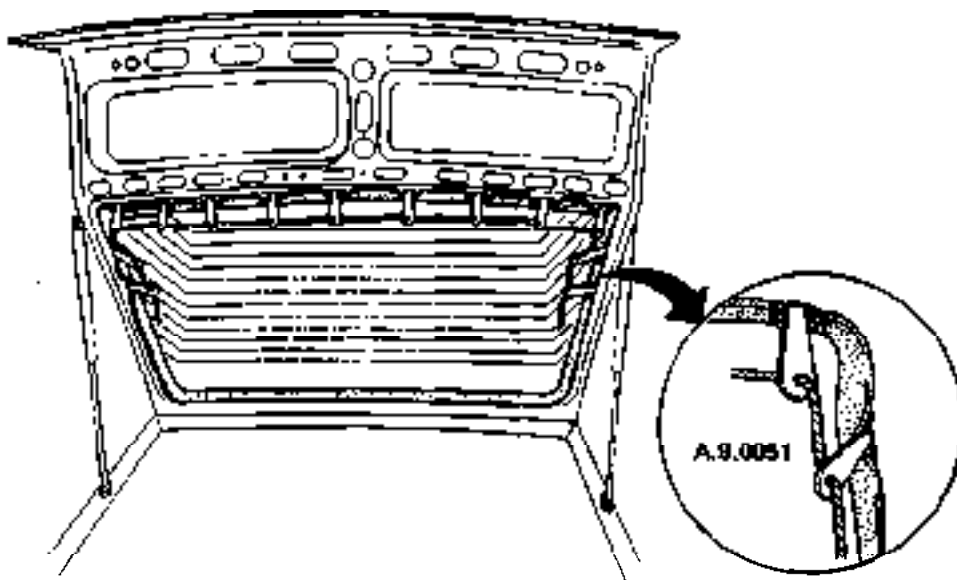

CAUTION:

Do not damage filaments of heated rear window with tool A.9.0051.

4. Carefully pull upper part of rear window, release it from back door and remove.

INSTALLATION

For installation; two operators are required.

CAUTION:

By means of silicone, lubricate rim of rear window weatherstrip in order to

allow an easy insertion of weatherstrip on body.

1. Into seal rim (2) insert two cords (A and B) arranged as per figure in order to allow repositioning of weatherstrip on back door.

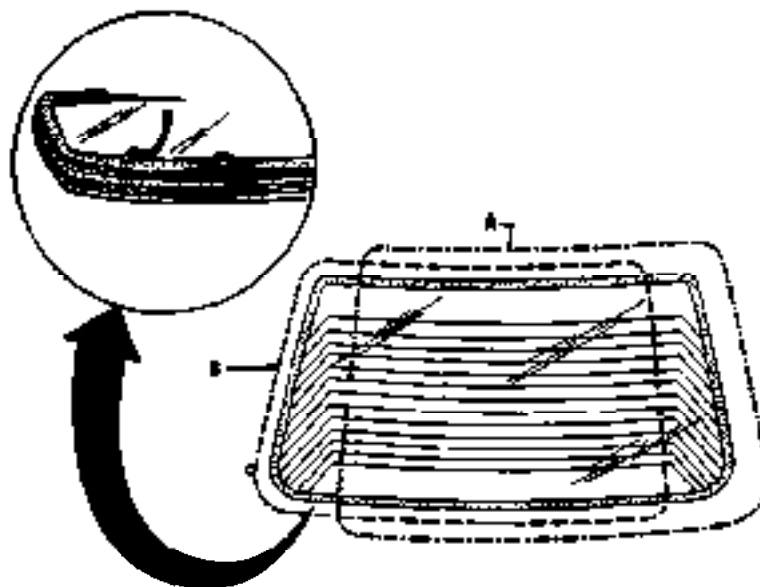

AIR VENTILATION

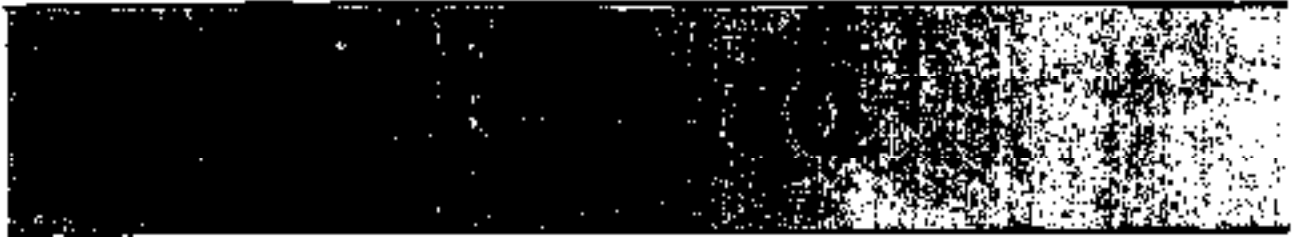

CONTENTS

WIRING DIAGRAM	80-2	Heater fan switch	80-5
AIR VENTILATION UNIT	80-3	TRUBLE DIAGNOSIS AND	
Removal and installation	80-4	CORRECTIONS	80-5

WIRING DIAGRAM--~

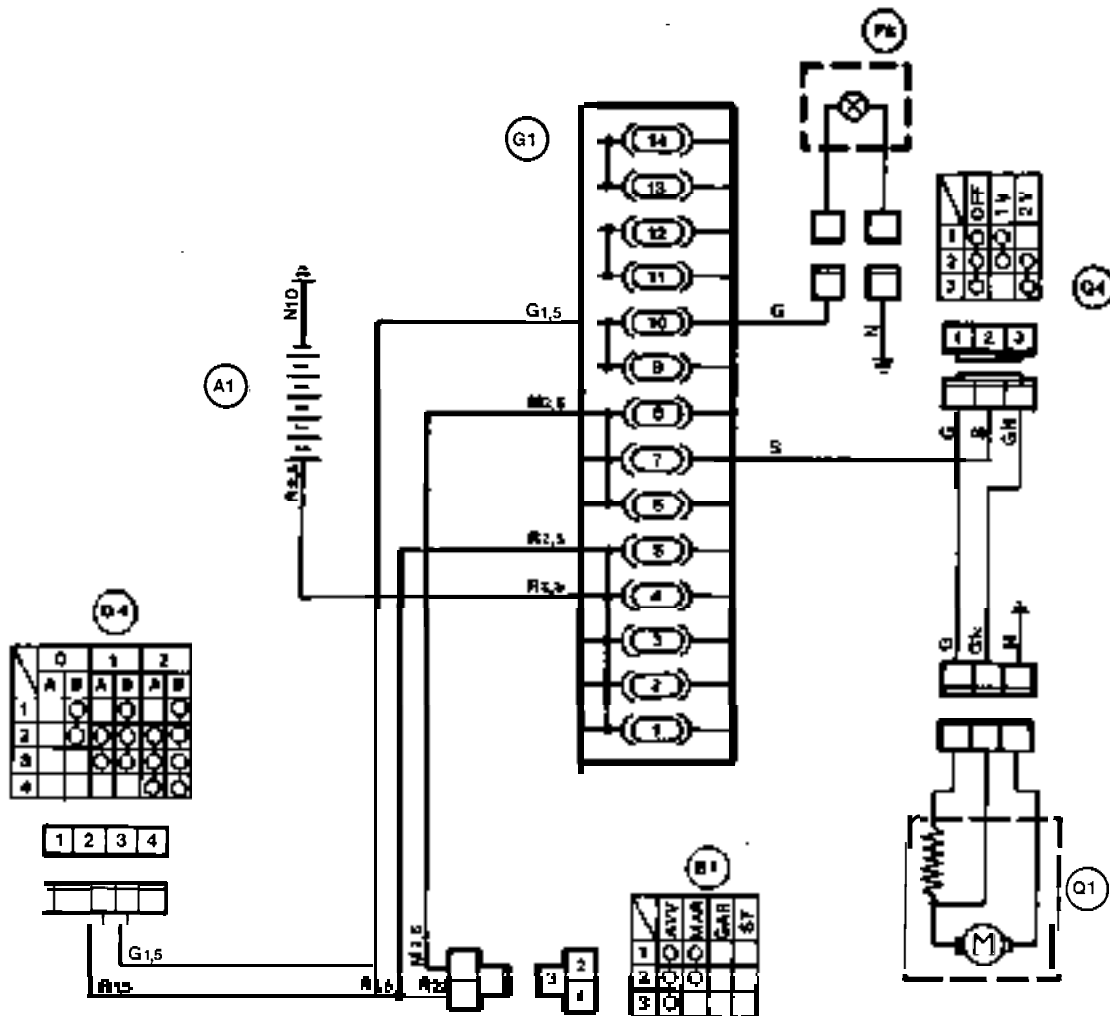

- A | Battery
- E1 Ignition switch
- B4 Control for headlight, flashing, low beam and full beam
- F8 Air ventilation control lamp
- G | Fusebox
- Q1 Air ventilation heater fan
- Q4 Air ventilation heater fan control
(IV - Low speed)
(2V - High speed)

HEATER

AIR VENTILATION UNIT

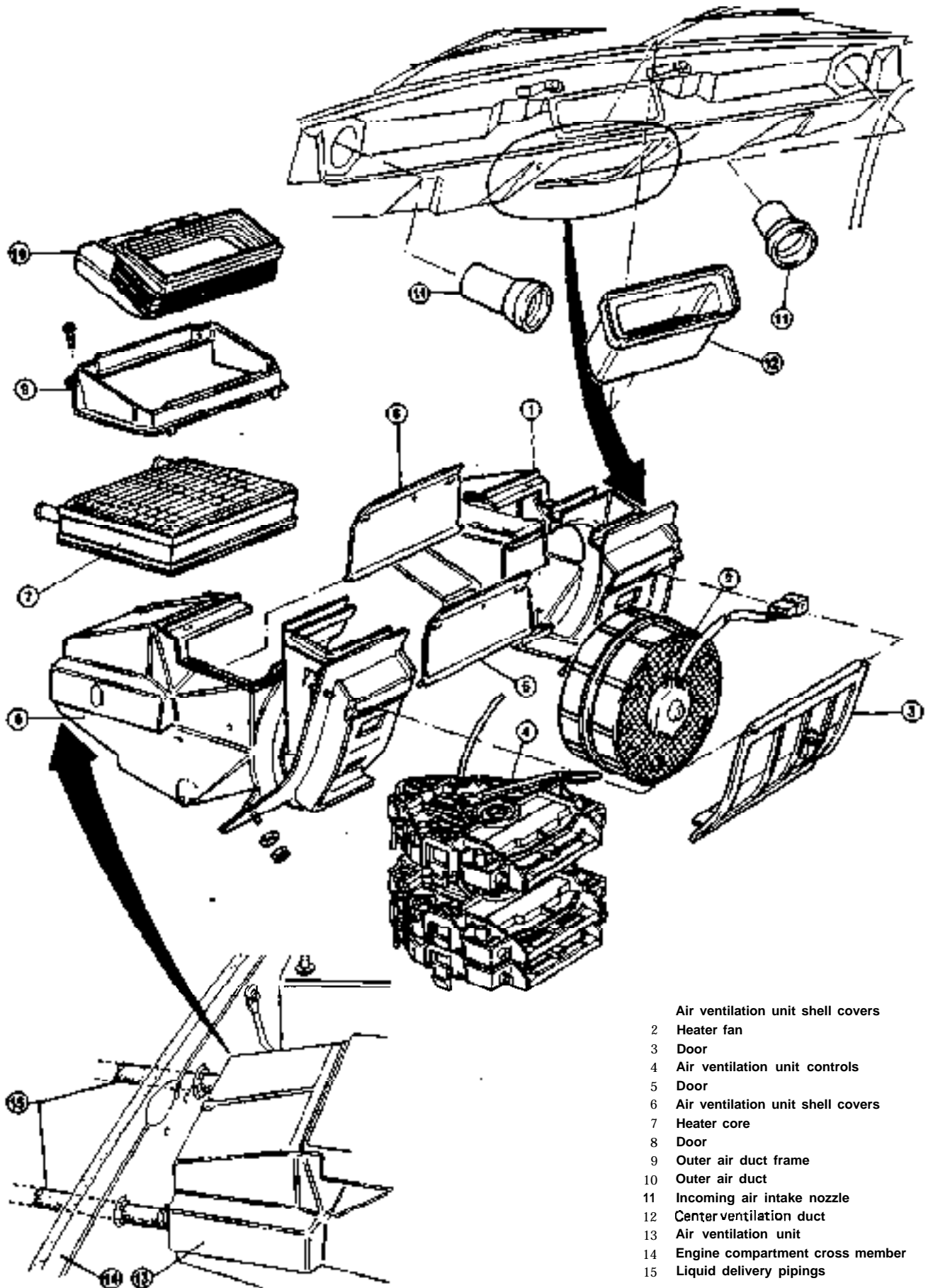

- 1 Air ventilation unit shell covers
- 2 Heater fan
- 3 Door
- 4 Air ventilation unit controls
- 5 Door
- 6 Air ventilation unit shell covers
- 7 Heater core
- 8 Door
- 9 Outer air duct frame
- 10 Outer air duct
- 11 Incoming air intake nozzle
- 12 Center ventilation duct
- 13 Air ventilation unit
- 14 Engine compartment cross member
- 15 Liquid delivery pipings

HEATER

REMOVAL AND INSTALLATION

CAUTION:

- Remove battery ground cable.
- Before removing components fitted with harness, make sure the relevant connections have been disconnected.
- Be careful when removing air ventilation unit pipings, otherwise liquid leakages from heater core may occur.

With reference to exploded view above proceed as follows:

1. Remove lower finisher of central console and unscrew the four screws securing air ventilation unit controls (4) to console (see Group 66 - Central Console).
2. Unscrew the four nuts securing air ventilation unit (13) to body.

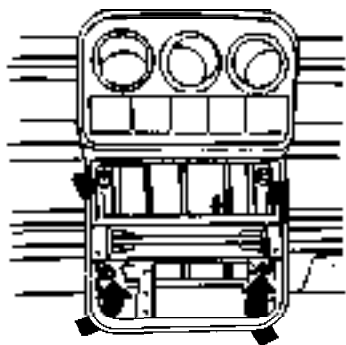

3. Operating from engine compartment inside, disconnect harness of heater fan (2).
4. By means of two terminals, clamp liquide delivery pipings (15) to air ventilation unit (13), in order to prevent leakages.

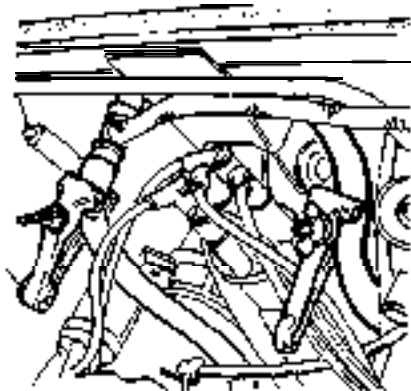

5. Loosen metal clamps securing pipings (15) to air ventilation unit; then remove pipings.

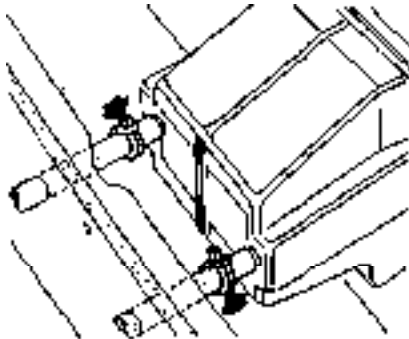

6. Unscrew the two screws securing frame (9) of outer air duct (10) to air ventilation unit; then remove both.

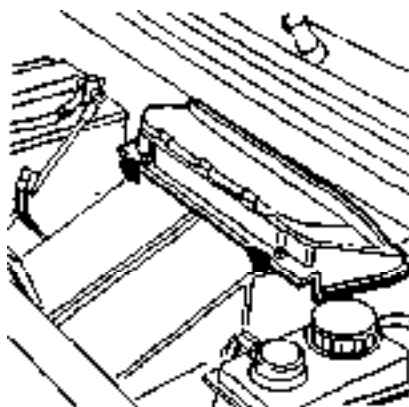

7. Carefully withdraw air ventilation unit and air ventilation unit controls (4).
8. If necessary, disassemble air ventilation unit in order to gain access to its inner components. (1) Operating as per figure, remove the eight springs keeping together shell covers (1) and (6) of air ventilation unit.

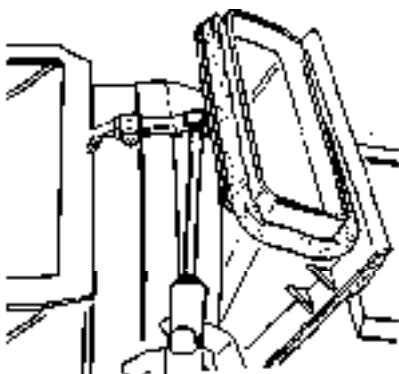

- (2) Remove or cut seals.
- (3) Separate the two shell covers (1) and (6).
- (4) If necessary, with reference to exploded view above, release control cables of doors (5) and (8) by operating with suitable wrench on the screw securing levers to door hinges as shown in figure.

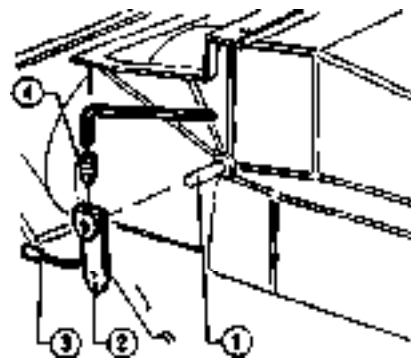

- 1 Door hinge
- 2 Lever
- 3 Door control cable
- 4 Screw

- (5) If required, disassemble components of air ventilation unit controls operating as per figure.

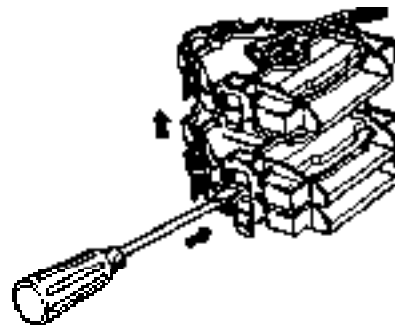

9. If necessary, operate on air ventilation unit components present in the dashboard by following the indications provided in Group 66 - Dashboard.
10. Install air ventilation unit by reversing order of removal.

HEATER

HEATER FAN SWITCH

LOCATION

The switch is located in the lower ornament of central console (see: Group 66 - Consoles).

CHECK

Check switch proper functioning by verifying that continuity between terminals occurs in compliance with the indications provided in table.

CAUTION:

- After restoring hydraulic connection, it is necessary to top up header tank of engine cooling system.
- Lubricate air ventilation unit control cables by means of proper oil.

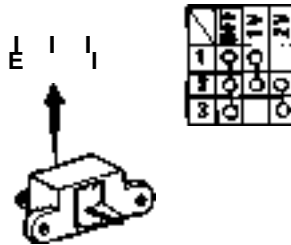

TROUBLE DIAGNOSIS AND CORRECTIONS

Condition	Probable cause	Corrective action
Insufficient heating performance (No heated air flow to ducts)	<ul style="list-style-type: none"> • Cooling water temperature too low • Heater care plugged <ul style="list-style-type: none"> • Insufficient cooling water level • Malfunctioning air mix door 	<p>Check thermostat: replace if necessary</p> <p>Clean heater</p> <p>Refill</p> <p>Check door and adjust</p>
Insufficient air flow to floor	<ul style="list-style-type: none"> • Blower motor speed too low • Malfunctioning air floor door • Malfunctioning door control 	<p>Check blower motor and:</p> <ul style="list-style-type: none"> -- restore poor connections -- replace blower motor if necessary <p>Check door and adjust</p> <p>Check control and adjust</p>
Insufficient defrosting performance (Cold air to ducts)	Refer to "No heated air flow to ducts"	
Insufficient air flow to defroster (Refer to: Group 66 - Dashboard)	<ul style="list-style-type: none"> • Blower motor speed too low • Malfunctioning air main duct door • Malfunctioning door central 	<p>Check blower motor and:</p> <ul style="list-style-type: none"> -- restore poor connections -- replace blower motor if necessary <p>Check door and adjust</p> <p>Check door control and adjust</p>
Control lever drags	<ul style="list-style-type: none"> • Bad cable sliding • Control cable bent excessively • Air intake door not operate properly 	<p>Adjust</p> <p>Correct</p> <p>Check and adjust</p>
Noise from blower motor	<ul style="list-style-type: none"> • Loose bolt in blower motor • Broken blower blade(s) 	<p>Check and tighten</p> <p>Replace blower</p>

