



MORGAN PLUS FOUR
OWNER'S HANDBOOK



PlusFour

WARNING

It is recommended that children are not transported in the vehicle.
Advanced driver training may be required to drive this vehicle.

SWARNUNG

Es wird empfohlen, dass Kinder nicht im Fahrzeug befördert werden.
Möglicherweise ist eine fortgeschrittene Fahrerschulung erforderlich, um dieses Fahrzeug zu fahren.

ATTENTION

Il est recommandé de ne pas transporter les enfants dans le véhicule.
Une formation de conducteur avancée peut être nécessaire pour conduire ce véhicule.

AVVERTIMENTO

Si raccomanda che i bambini non vengano trasportati nel veicolo.
Per guidare questo veicolo potrebbe essere necessario un addestramento avanzato del conducente.

ADVERTENCIA

Se recomienda que los niños no sean transportados en el vehículo.
El entrenamiento avanzado del conductor puede ser requerido para conducir este vehículo.

警告

建议儿童不要在车内运输。
驾驶该车辆可能需要高级驾驶员培训。

ريڤت

قرايسال يي لافطالال لقرن مدعب صوي
هذه اداقيل مدقت مال قئاسال ابيردتل اءاح لكانه نوكت دق
قرايسال

The content contained within this handbook is correct at the time of publication,
however due to the nature of Morgan motor vehicle production, some details may be subject to change.

Version 1.0, March 2020 - 21MY

© Morgan Motor Company 2020

CONTENTS

Welcome.....	2
Vehicle Identification.....	3
Technical Information.....	4
Safety Information.....	7
Locks, Keys and Security.....	9
Seating and Safety Restraints	9
Instruments and Switches.....	12
Driver Information Panel.....	16
Control Stalks.....	21
Lights, Indicators and Wipers.....	22
Transmission Modes.....	24
Gear Modes.....	27
Under Dashboard Functions.....	28
Foot Operated Controls.....	29
Hand Operated Controls.....	30
Heating Ventilation and AC.....	31
Starting Procedure.....	31
Hood Operation.....	32
Fuel Filling.....	37
Bonnets.....	38
Tyres.....	39
Fuse box.....	42
Battery.....	42
Maintenance.....	46
Cleaning.....	50
Warranty.....	52
Service History.....	57



WELCOME TO THE WORLD OF MORGAN

Your car is as individual as you are, and employs traditional coach-building techniques, using only the highest quality materials – leather, aluminium and seasoned ash. Each Morgan is built to an individual specification. Morgan uses the latest drive-train technology, using a lightweight, powerful engine that meets current standards in emissions and fuel economy.

MORGAN PLUS FOUR

This handbook has been produced in order to give the owner a good understanding of how best to use and enjoy their Morgan Plus Four. The owner/driver should read and understand the content of this handbook before using the car, and the handbook should then be kept in the car for reference at any time. It should be passed on to new owners if the car changes hands.

To get the full enjoyment of driving this vehicle, it is recommended that the owner undergoes advanced driver training. Contained within the handbook are important safety warnings and instructions. These warnings are to prevent any risk of injury being caused to you or others. This book is intended to give an understanding of the operating procedures and general servicing instructions as well as technical information. It is not intended to give comprehensive technical details and full servicing procedures.

To ensure maximum pleasure and performance, it is important to keep your Morgan well maintained and serviced at the correct intervals. It is the responsibility of the owner to ensure the vehicle is serviced at the correct periods. If any adjustment is required we request that you contact a Morgan dealer for advice before any work is carried out. Alterations from the standard specification are not recommended as this may affect the performance and safety of the vehicle and invalidate the warranty.



VEHICLE IDENTIFICATION

Morgan advises that the Vehicle Identification Number (VIN) is recorded in this section along with other records that may be useful when requesting or ordering replacement parts.

The VIN (Vehicle Identification Number) plate is positioned under the left bonnet on the inner panel ahead of the A-Post. The VIN Number is stamped into the chassis behind the right hand seat under the carpet.

VIN:

Registration:

Body Colour:

Trim Colour:

Hood Colour:

Paint Colour Code:

Warranty Start Date:

Supplying Dealer Information:

MORGAN PLUS FOUR TECHNICAL INFORMATION

Engine Information

Engine.....	BMW 2.0L (1998.3cc) in-line four cylinder direct injection with twin scroll turbo.
Cylinders	4
Capacity	1998.3cc.
Bore (mm)	82
Stroke (mm)	94.6
Compression Ratio	10:2:1
Firing Order	1-3-4-2
Power Net (kW)	190 kW at 6000rpm
Torque Nm	Manual: 350 Nm Automatic: 400 Nm
Valve Operation	2 overhead camshafts, chain driven
Valve Timing	Variable valve timing system

Fuel System

Type	Electronic fuel injection
Fuel Pressure kPa (psi)	600 BAR 35000 kPa
Fuel Type	98 or 95 RON unleaded petrol
Ethanol Rating.....	E10

Ignition System

Type	Digital electronic
Operation.....	ECU controlled, direct coil
Spark Plug	NGK/Champion R5/R6 Gap 0.75mm

Cooling System

Type	Engine driven water pump, electronically controlled water management module, radiator, twin electric cooling fans.
Normal Operating Temp.	85 – 115°C

Air Conditioning System

Refrigerant.....	R1234yf - 650g
Oil.....	Denso ND-12

Capacities

Fuel Tank (approx.)	43 litres (10 US Gall.)
Windscreen washer bottle	2.5 litres (0.7 US Gall.)
Engine oil with new filter	5.25 litres (1.4 US Gall.)
Rear Differential	1.7 litres (0.5 US Gall.)

Oil and Fluid Specifications

Engine	5W-30
Gearbox Oil - Manual.....	MTF-LT-5
Gearbox Oil - Automatic.....	Shell L12108
Rear Differential Oil	G1 HYPOID Axle Oil G3 synthetic oil of the highest grade.
Engine Coolant Type	BMW HT-12 Mix ratio 50% for coolant down to -38°C.
Brake Fluid	DOT 4

Transmission - Manual

Gear Box	6-speed manual transmission with Comfort and Sport+ engine modes.
Differential	Ratio 2.81:1

Transmission - Automatic

Gear Box	8-speed automatic transmission with Comfort, Sport and Sport+ shift modes.
Differential	Ratio 2.81:1

Gear Ratios - Automatic

Gear	Ratio
1 st	5.25
2 nd	3.36
3 rd	2.172
4 th	1.72
5 th	1.316
6 th	1
7 th	0.822
8 th	0.64

Gear Ratios - Manual

Gear	Ratio
1 st	3.683
2 nd	2.062
3 rd	1.313
4 th	1
5 th	0.809
6 th	0.677

Suspension

Front	Double wishbone with anti-roll bar
Rear	Double wishbone
Caster Front	5°30'
Caster Rear	N/A
Camber Front	-0° 30' +/- 15'
Camber Rear	-0° 45' +/- 15'
Toe In Front	+0.50mm +/- 0.25mm
Toe In Rear	+1mm +/- 0.25mm

Brakes

Front	Floating single piston aluminium caliper, 294mm (diameter) x 24mm (thickness) ventilated disc.
Rear	1-piston aluminium caliper, 288mm (diameter) x 20mm (thickness) ventilated disc with integral self-adjusting handbrake.
Handbrake	Cable operated, self-adjusting.
Operation	Hydraulic with vacuum servo assistance, ABS standard.
Operating Fluid	DOT 4

Wheels and Tyres*

Wheels Standard	15x6.5 (Alloy)
Wheels Option 1	15x6.5 (Wire)
Wheels Option 2	16x7 (Wire)
Tyres Front Standard	Cooper Avon ZV7 205/60 R15 91V
Tyres Rear Standard	Cooper Avon ZV7 205/60 R15 91V
Tyres Front Option 1	Yokohama BluEarth AE50 205/60 R15 91V
Tyres Rear Option 1	Yokohama BluEarth AE50 205/60 R15 91V
Tyres Front Option 2	Yokohama BluEarth ES32 205/55 R16 91V(W)
Tyres Rear Option 2	Yokohama BluEarth ES32 205/55 R16 91V(W)
Tyre Pressures	28psi/193 kPa
Wheels/Torque Setting	15" Wire or 16" Wire or 15" Alloy/80lb/ft(110Nm)

Chassis

Wheelbase (fully loaded)	2520mm (99.21 in)
Track Front	1492mm (58.74 in)

Track Rear	1492mm (58.74 in)
Ground Clearance Front Axle	125mm (4.92 in)
Ground Clearance Rear Axle	135mm (5.31 in)
Turning Circle	4.29m (14 ft)

Overall

Length	3830mm (150.79in)
Width (Base Wheels)	1650mm (64.96 in)
Width (Option Wheels)	1665mm (65.55 in)
Height	1235mm (48.62 in)

Technical Information

Vehicle in Running Order (Including Fuel) - Auto	1115kg
Vehicle in Running Order (Including Fuel) - Manual	1119kg
Maximum permissible mass	1300kg
Maximum weight per axle (Front)	624kg
Maximum weight per axle (Rear)	676kg
This vehicle is not designed for towing.	

Fuel Consumption and Carbon Dioxide Emissions**

MANUAL:	AUTOMATIC:
Low CO ₂	240.1 g/km
Medium CO ₂	146.6 g/km
High CO ₂	130.6 g/km
Extra High CO ₂	160.4 g/km
Combined CO ₂	159 g/km
Low	26.7 mpg
	10.6 l/100km
Medium	43.7 mpg
	6.5 l/100km
High	49.0 mpg
	5.8 l/100km
Extra High	39.9 mpg
	7.1 l/100km
Combined	40.2 mpg
	7.0 l/100km

*Not all options may be available to purchase from Morgan Motor Company at launch.

**All figures quoted are WLTP declared values.



SAFETY INFORMATION

Throughout this handbook there are important  SAFETY WARNINGS as well as safety warning labels located on the Morgan Plus Four. These safety warnings are there to help you make informed decisions and reduce the risk of accidents causing possible injury or death to yourself or others. There are also CAUTIONS and NOTICES to assist you in making decisions to avoid damage to your Morgan Plus Four or other property.

SAFE USE OF THE MORGAN PLUS FOUR

Your safety and enjoyment of your high performance sports car is Morgan's priority, therefore it is highly recommended that you take time to familiarise yourself with the safe operation of your Morgan vehicle before driving it.

MISUSE OF THE MORGAN PLUS FOUR

Your Morgan Plus Four is intended to be used in a safe manner, always obey the local laws and speed limits, never travelling faster than is appropriate for the road, weather and traffic conditions. Accidents may cause injury or death to both the occupants of the vehicle and/or other persons. Remember that using sensible judgement when driving this high performance vehicle may prevent an accident from occurring.

RESPONSIBILITIES OF THE OWNER

As the owner of this vehicle, you are responsible for the safe and proper operation of this vehicle. This is a high performance vehicle and safe use is dependent upon the practice of safe driving technique as well as the expertise of the driver.

It is highly recommended that every owner should:

- Obtain instructions from a competent source on all aspects of the operation of this high performance vehicle.
- Understand that this vehicle is not fitted with airbags or electronic stability control systems. An Anti-Lock Braking System (ABS) is fitted to this vehicle.
- Observe the warnings and maintenance requirements contained within this Owner's Manual.
- Obtain qualified training in safe and proper driving techniques, applicable to high performance vehicles.
- Know your own limits and skill level. Driving safely within your own limits may help you to avoid an accident.
- Take particular care when driving on wet or slippery surfaces.

IMPORTANT SAFETY WARNINGS

- Always ensure that the car is in a roadworthy condition. It is the responsibility of the driver to ensure that the vehicle is in a proper and roadworthy condition.
- The driver and passenger must be seated correctly and should ensure that all safety restraints are used properly and are free from obstructions.
- Check that the tyres are in good condition with no excessive wear or damage.

- Ensure all windows and mirrors are clear and positioned correctly before driving.
- Ensure that all doors, bonnets and hoods (when fitted) are fastened/shut correctly.
- Check all lights and signalling devices are operating correctly before use.

Always Wear a Seat Belt

Wearing a seat belt will dramatically reduce the risk of injury or death in the event of an accident. Always ensure that the driver and any passengers travelling in the vehicle always wear a seat belt.

-  Morgan Motor Company recommend that young children are not carried in a Morgan Plus Four.

Harmful Substances





Some components used in the manufacture of cars contain or emit chemicals known to increase the risk of cancer and birth defects as well as increasing the risk of reproductive harm.

Exhaust gases contain carbon monoxide (CO). This gas cannot be seen, has no odour and exposure to the gas can cause unconsciousness or death. If it is suspected that exhaust gases are entering the cockpit of the car do not drive the car until a Morgan engineer has rectified the fault. Never park in a confined space with the engine running without adequate ventilation.

Engine System

If the engine malfunctions in any way, ECU warnings show on the LCD screen. Morgan recommends that the fault is diagnosed and repaired by a Morgan engineer before using the vehicle. Failure to react appropriately to any engine management faults may result in permanent damage to the

engine. Continuing to drive the car with an engine misfire could cause the catalytic converter to overheat, with possible heat damage to other car components, and an engine bay fire.

-  **DO NOT** park or drive the car in areas where combustible material, such as dry grass or leaves, could come into contact with the hot exhaust system as this may ignite fires.
-  **DO NOT** tamper with the electrical system whilst the battery is connected.
-  **DO NOT** enter the engine bay when the engine is running.
-  **DO NOT** use the car if a fuel leak is suspected. Ensure that a Morgan engineer or service agent repairs the fault before starting or using the vehicle. Leaking fuel may cause fires or explosions.
-  **DO NOT** touch or approach any part of a hot exhaust system. Failure to comply with this may result in injury.

It is recommended that any work to be performed on a Morgan Plus Four should be undertaken by a qualified engineer or Morgan service agent.

Electrical Equipment

Morgan does not recommend installing any non-approved electronic systems that emit radio frequencies. Such items include electronic garage door activation and similar devices.

VEHICLE SECURITY - KEYS

The Morgan Plus Four may be supplied with two keys for the vehicle ignition system, and a Remote Central Locking fob. Contained within the ignition key is a chip used to disarm the engine immobilisation system. The Morgan Plus Four can only be started with a key containing the correct chip corresponding to the correct vehicle.

⚠ WARNING While the car is fitted with an immobiliser, there is no alarm system supplied on the Morgan Plus Four. Do not leave the car unattended with the keys in the ignition.

Remote Central Locking (RCL)

The Morgan Plus Four may be provided with 2 RCL fobs that can be activated by pressing either of the buttons on the RCL fob. To lock the doors press the lower button on the fob marked with a lock icon for approximately 1 second. To unlock the doors press the top button on the fob marked with an unlock icon for approximately 1 second. When unlocking the car with the key fob the lights will come on for 10 seconds. The range from which the fob will operate the locks will vary depending on environmental conditions and the RCL fob battery condition. Replacement fob batteries can be obtained from your nearest Morgan service agent.



RCL Fob

Ignition Key

Door Locks - Manual Operation

Manual locking operation using the ignition key is only required if there is an RCL fault. There is no manual door lock on the passenger side. To unlock the driver's door from outside the vehicle, insert the ignition key into the lock and rotate anti-clockwise until the stop is reached, then remove the key. The door is now unlocked.

⚠ WARNING Never lock the vehicle when a person or animal is inside the vehicle. Never leave the vehicle unattended and unlocked.

⚠ WARNING Do not force the lock mechanism. If the key does not go into the lock or the lock will not operate, lubricate with light grade oil. If the problem persists, consult a Morgan engineer.

Engine Immobiliser

The Morgan Plus Four is fitted with an engine immobiliser. This means that the engine can only be started using the correct keys programmed to the vehicle.

SEATING AND SAFETY RESTRAINTS

Seats

The seats in the Morgan Plus Four are adjustable both fore/aft, rake angle and lumbar support and should be adjusted to suit. To adjust the fore/aft position of the seats, raise the lever located under the front of the seat. This will allow the seat to slide fore/aft. Once in the desired position release the lever and the seat will be engaged in position. It is important to check that the seat is engaged fully in position by attempting to slide the seat fore/aft without touching the lever.

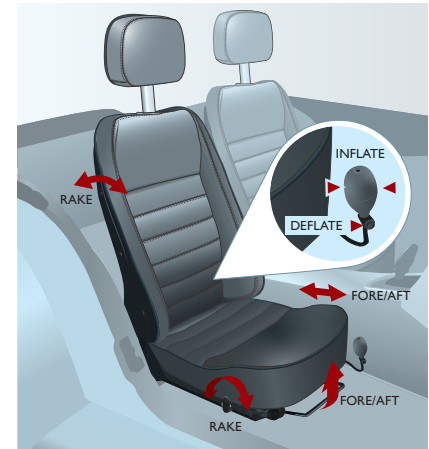

To adjust the rake angle of the seat, sit in the seat and operate the lever to the side of the seat base. Any attempt to engage the rake angle lever without sitting in the seat could result in injury.

Back support (lumbar) can be adjusted to provide different pressure, depending on the level of firmness required. To increase firmness, squeeze the rubber hand pump. Press the valve button below the hand bulb to decrease pressure.

 **WARNING** Do not adjust the seat position whilst the vehicle engine is running.

 **WARNING** Ensure that no objects can be trapped when the seats are moved/adjusted.

Seat Belts

Seat belts should be worn at all times when in the vehicle. It is a proven fact that wearing seat belts reduces the risk of injury or death in the event of an accident, wearing a seatbelt incorrectly increases the chances of serious injury or death in the event of a crash. When the ignition is turned on there will be a warning light and once the vehicle reaches 5mph an audible warning reminding the occupants to fasten their seat belts.

The seat belt units fitted to the Morgan Plus Four are inertia reel seat belts. The seat belts may lock automatically when the vehicle is subjected to extreme braking, acceleration, cornering and impact forces. The seat belt unit may also lock if the vehicle is tilted in any way.

Local rules and restrictions associated with seat belts may apply. It is the driver's responsibility to ensure both the driver and passenger adhere to local laws. When fastening the seat belt sit in the seat erect and fully back. Hold the buckle tongue and draw the belt diagonally across the body and fasten into the buckle lock. Ensure the buckle is secured and correctly engaged; this will

be apparent by a click sound when fastening the buckle tongue into the buckle lock. Ensure that the belt sits across the front of the pelvis and across the chest and shoulder.

To release the belt push the red button on the buckle. The belt will automatically retract.

 **WARNING** Driver and passenger seat belts should always be worn properly. Wearing a seat belt incorrectly increases the chance of serious injury or death in a crash.

 **WARNING** When the vehicle is in motion above 5mph and weight is detected in the passenger seat, the vehicle will emit an audible warning unless the seat belt is fastened.

 **WARNING** When fastening the seat belt, ensure that the belt is not twisted or entangled in the door or seat mechanism.

 **WARNING** Seat belts are designed to bear upon the bone structure of the body and should be worn low across the front of the pelvis, chest and shoulder. Wearing the lap section of the belt across the abdominal area must be avoided.

 **WARNING** Improperly positioning the seat belts can cause serious injury or death in a crash. Ensure the seat belts are correctly positioned before driving.

 **WARNING** Seat belts should be worn by all persons regardless of the physical condition of the person. For example, pregnant women should always wear a seat belt.

 **WARNING** The shoulder portion of the seat belt must never be worn beneath the arm or behind the back.

⚠ WARNING Each seat belt assembly is designed for use by one occupant of adult build, and it is not recommended that they are used by children.

⚠ WARNING A child seat must never be used in the seats of a Morgan Plus Four.

⚠ WARNING Never use one seat belt around two people, or allow a child to be carried on a driver or passenger's lap.

⚠ WARNING No modifications or additions should be made to the seat belt assemblies.

⚠ WARNING The seat belt should be replaced if components are frayed, contaminated or damaged. Inspect regularly.

⚠ WARNING The seat belt system must be replaced if the vehicle has been involved in a severe impact, even if no damage to the assembly is visible. Seat belt anchorage points must also be checked.

⚠ WARNING Not checking or maintaining seat belts can result in serious injury or death if the seat belts do not work properly when needed. Check the seat belts regularly and ensure that any problems are corrected immediately.

⚠ WARNING Seat belts should be adjusted as firmly as possible, consistent with comfort, to provide the protection for which they have been designed. A slack seat belt will greatly reduce the protection afforded to the wearer.

⚠ WARNING Seat belts should not be worn with the straps twisted.

⚠ CAUTION When cleaning the seat belt assembly, care should be taken to avoid contamination or damage to the system.

⚠ CAUTION Do not use any substance that may contaminate or damage the webbing material. Never use bleach or dye, only clean with a mild detergent and ensure the system is completely dry before using the vehicle. Ensure the entire system is kept free of dirt contamination.

⚠ WARNING Do not disassemble the system for cleaning purposes.

AIR BAGS

⚠ CAUTION Morgan Plus Four is NOT FITTED with driver and passenger air bag systems.

INFANT PASSENGERS

⚠ WARNING Morgan Motor Company recommends that children who require additional safety restraints are not transported in a Morgan Plus Four. Only carry people in a Morgan Plus Four who are able to use the seat belts as intended without any modification or seating aid. Child booster seats are not recommended for use in a Morgan Plus Four.

INSTRUMENTS AND SWITCHES

Central Dashboard - RHD



1. Speedometer
2. Analogue Clock
3. Tachometer

4. Odometer & Trip meter
5. Trip Reset Button
6. Heater Fan Control

7. Footwell Vent
8. Air Conditioning
9. Ignition/Engine Start

10. Hazard Warning
11. Heated Windscreen
12. Temperature Control
13. Rev Limit Warning Light

INSTRUMENTS AND SWITCHES

Central Dashboard - LHD



1. Tachometer
2. Analogue Clock
3. Speedometer

4. Rev Limit Warning Light
5. Heater Fan Control
6. Footwell Vent

7. Air Conditioning
8. Ignition/Engine Start
9. Hazard Warning

10. Heated Windscreen
11. Temperature Control
12. Trip Reset Button
13. Odometer & Trip Meter

INSTRUMENTS

Speedometer (1 RHD, 3 LHD)

The speedometer indicates the road speed of the vehicle. The display is miles per hour (mph) and/or kilometres per hour (kph).

Clock (2)

To advance the hands in a clockwise direction, carefully press the small right-hand button on the clock face (using a small, blunt device makes this easier). Pressing the button once will advance in one minute increments. If the button is held down for longer, a continuous movement of the hands is achieved. The left-hand button acts in the same way, except the movement is in an anti-clockwise direction.

Tachometer (3 RHD, 1 LHD)

The tachometer displays the engine speed in revolutions per minute (rpm).

 **WARNING** The use of excessive RPM when an engine is not at normal running temperature may cause premature wear, damage to the engine and failure of engine components.

Odometer (4 RHD, 13 LHD)

Located in the LCD screen in the bottom of the speedometer, the odometer records total distance that the vehicle has travelled.

Trip Meter (4 RHD, 13 LHD)

Located in the LCD screen at the bottom of the speedometer is the trip meter, which can be used to record a distance from a set starting point.

Trip Reset Button (5 RHD, 12 LHD)

The trip meter can be re-set to zero by pressing and holding the button.

PUSH BUTTON SWITCHES

Heater Fan Control (6 RHD, 5 LHD)

Rotate the Heater Fan Control knob clockwise to increase fan speed. Rotate anti-clockwise to reduce fan speed. A Heater Fan Control icon appears in the Driver Information Panel.

Footwell Vent (7 RHD, 6 LHD)

When pushed on, the switch will display in white. Air is directed into the footwell.

Air Conditioning (8 RHD, 7 LHD)

When pressed, this button engages the compressor on the engine. The engine speed may slow for a short time when first switched on. Cold air will be directed through the heater vents. Press the button again to turn off.

CAUTION Make sure the heater vents are open before turning on the air conditioning.

Ignition/Engine Start (9 RHD, 8 LHD)

When the key is turned once, the ignition will start. When turned for a second time, with the ignition key set to the second position, push the Start button to start the ignition. Whilst pressing and holding the brake pedal (automatic) or clutch pedal (manual), press and hold the Start button to start the engine.

NOTE: The engine will not start unless the foot brake (automatic) or clutch pedal (manual) is depressed firmly.

Hazard Warning Switch (10 RHD, 9 LHD)

When pushed on the switch will flash red in conjunction with all the direction indicators on the vehicle. The left and right indicator icons in the Driver Information Panel will flash. Hazard lights should be used in an emergency. In the case of an emergency, move the vehicle to a safe position and turn the hazard lights on.

Heated Windscreen ^(11 RHD, 10 LHD)

The heated windscreen is turned on by pushing the switch located on the dashboard. When turned on, the heated windscreen icon will display on the Driver Information Panel and the button will emit an amber light. Elements in the windscreen will heat up, defrosting/defogging the windscreen. This function will automatically turn off after approximately 10 minutes.

Temperature Control ^(12 RHD, 11 LHD)

Rotate the Temperature Control knob clockwise to increase interior temperature, or anticlockwise to reduce interior temperature. A Temperature Control icon appears in the Driver Information Panel.

Rev Limit Warning Light ^(13 RHD, 12 LHD)

A warning light will come on in the Tachometer when the vehicle reaches 200rpm from its maximum limit.

 **WARNING** Prolonged excessive rpm may cause damage to the engine.

Rear Fog Lamp

Twisting the inner collar of the indicator stalk upwards turns on the rear fog lamp. When turned on, a symbol will display on the Driver Information Panel. The rear fog lamp will only operate when the vehicle lights are switched on. The fog lamp will automatically turn off when the ignition is turned off.

Fuel Level Gauge

Your Morgan Plus Four is equipped with a visual fuel gauge. The gauge will indicate that the tank is full of fuel when the needle is positioned to the far right of the gauge. As the fuel is used, the needle will move towards the left hand side of the gauge, representing the amount of fuel remaining in the tank. A warning light at the bottom of the gauge will come on when the fuel reaches approximately 6 litres (1.6 US Gallons).

 **WARNING** Do not allow your vehicle to run completely out of fuel. This may cause damage to engine, emissions and fuel system components.

Engine Coolant Temperature

The engine coolant temperature is displayed on a gauge located on the instrument panel. The engine coolant temperature should remain within the normal range in all running conditions. Check that when at normal operating temperature the gauge is positioned in approximately the 12 o'clock position. If the gauge indicates that the engine coolant is higher than normal, proceed with caution. The engine coolant level should be checked after the coolant temperature has reduced. This check should take place before the vehicle is driven any further. A warning light at the bottom of the gauge will come on when the coolant reaches too high a temperature. If this situation occurs, the engine should be stopped (at the next safe place) and the engine left to cool. The vehicle should then be inspected by a Morgan Service agent before further use.

 **WARNING** High engine coolant temperatures can cause serious and permanent damage to an engine. Never check the engine coolant level when the coolant is hot. Remove the coolant top up cap slowly using using heavy duty gloves that will protect protect from scalding from steam or hot coolant.

 **WARNING** If the coolant temperature exceeds a pre-defined threshold, engine power will automatically be reduced to to reduce the risk of damage to the engine and drivetrain.

DRIVER INFORMATION PANEL

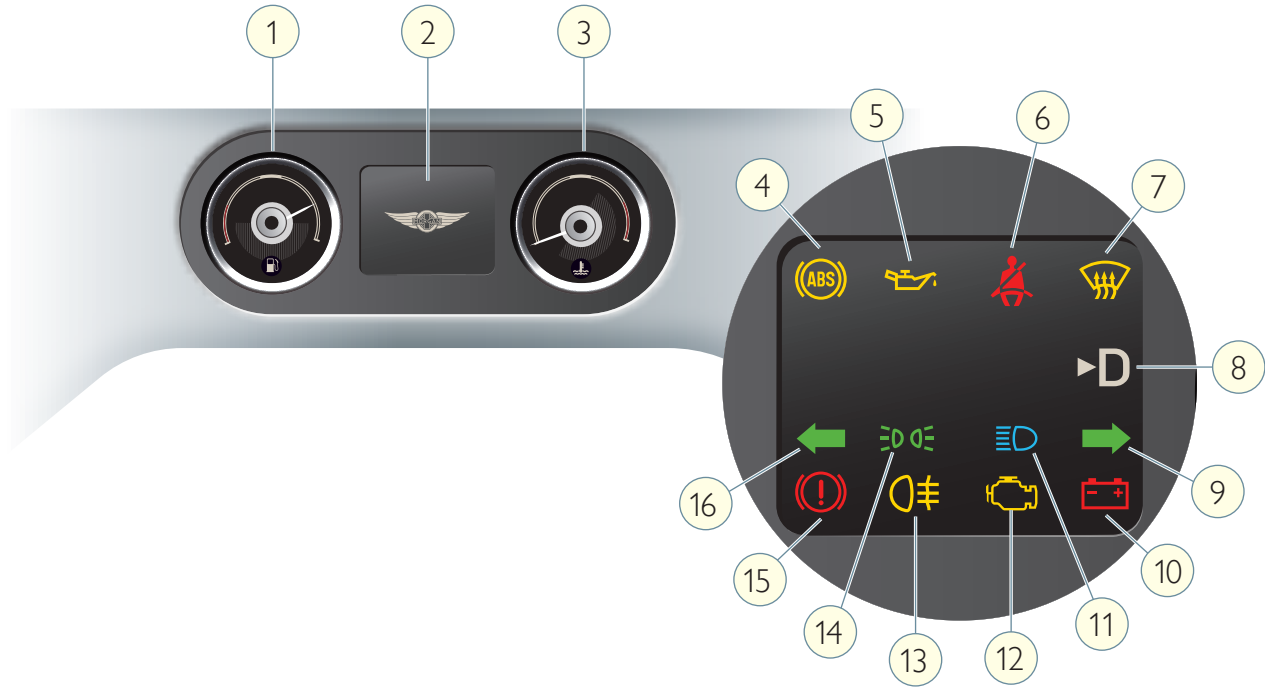

1. Fuel Gauge
2. LCD Screen
3. Coolant Temperature
4. ABS Warning Indicator

5. Oil Level / Oil Pressure Warning
6. Check Seat Belt
7. Heated Screen
8. Selected Drive Mode
(Automatic Vehicles Only)

9. Right Indicator
10. Battery Charge Warning
11. High Beam or Auto Lights
12. Check Engine

13. Fog Lamp
14. Side Lights
15. Brake Warning
16. Left Indicator

DRIVER INFORMATION PANEL ICON EXPLANATION



Door Open.



On.



Fan.



Heater.



Exterior Temperature.



Ice Warning.



Measurement Started.



Conditions Not Met.
No Measurements Available.



Secure Vehicle Against Rolling.



Powertrain Breakdown.
Stop At Once!



Gearbox Overheat.
Stop Carefully.



Engine Overheat.
Stop Carefully.



Overseer Off.



Overseer Fault.



Oil Level Below Min.



Oil Level.



Drivetrain.
Drive moderately.
Check soon.
Gearbox Getting Hot.
Gearbox Faulty.



Engine Oil Pressure.
Drive Moderately.



Oil Level Below Min.



Oil Level Check Required.



Washer Low.



Gearshift Not Possible.
(Automatic cars only)



Oil Level at Max. Allowed.



Oil Level Over Full.

DRIVER INFORMATION PANEL

⚠ WARNING Operating the driver information panel menus during driving can cause distraction, resulting in loss of control of the vehicle, accident, serious injury or death to the occupants of the vehicle and others. Only operate the driver information menu if permissible in the traffic situation. Stop if necessary and operate the system with the vehicle at a standstill.

It is recommended that the various checks in the Driver Information menus are carried out before a journey. To activate the scrolling menus on the Driver Information Panel, ignition must be on. To toggle through the menus, press the button on the end of the right stalk.

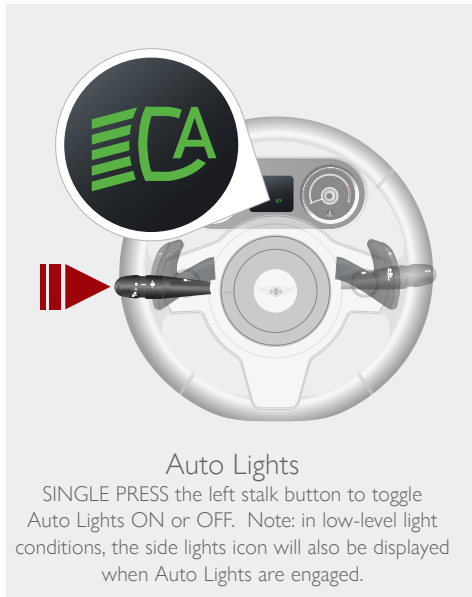

DRIVER INFORMATION PANEL - OIL LEVEL

It is recommended that an oil level check is carried out periodically.
To activate an oil level measurement, the vehicle should be:

1. Parked on a level surface.
2. Park or Neutral gears selected.
3. The engine should be running at normal operating temperature.

⚠ WARNING Do not scroll through Driver Information menus while driving the vehicle.

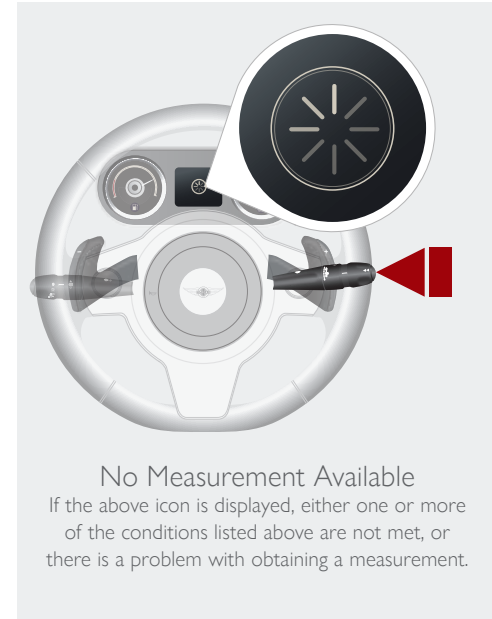
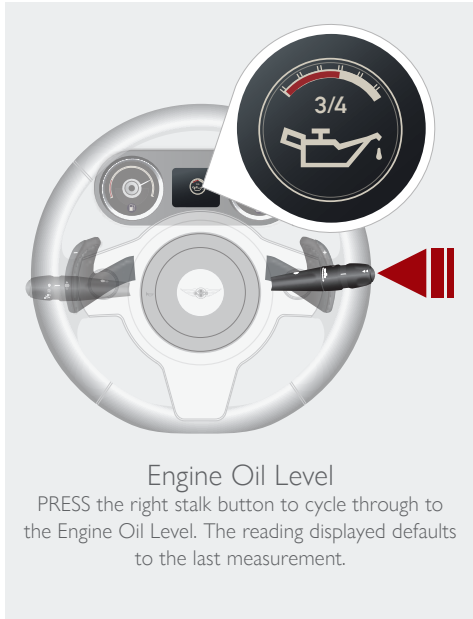

DRIVER INFORMATION PANEL - CONTINUED

Continue to press the right stalk button to select the following information:

 **WARNING** Do not scroll through Driver Information menus while driving the vehicle.

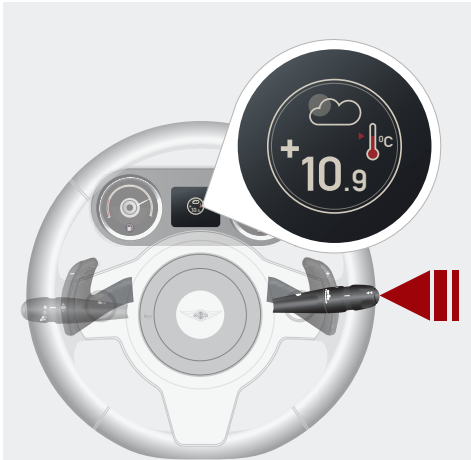

Outside Temperature

PRESS the right stalk button to cycle through the menu to display the outside temperature measurement.

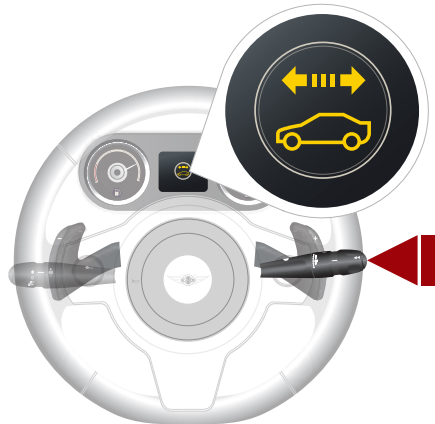

Amber Warning Symbols

Amber Warning messages may be present while cycling through the Driver Information menu. To clear each message, PRESS and HOLD the right stalk button. To view the cleared message, PRESS the right stalk button until the last screen is reached.

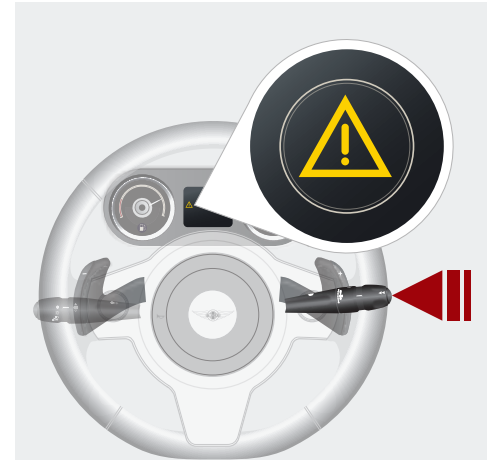

Check Message Warning Symbol

When any red or amber warning symbol is present, the check message warning triangle will also show. This symbol will remain after the original warning symbol is cleared.

CONTROL STALKS

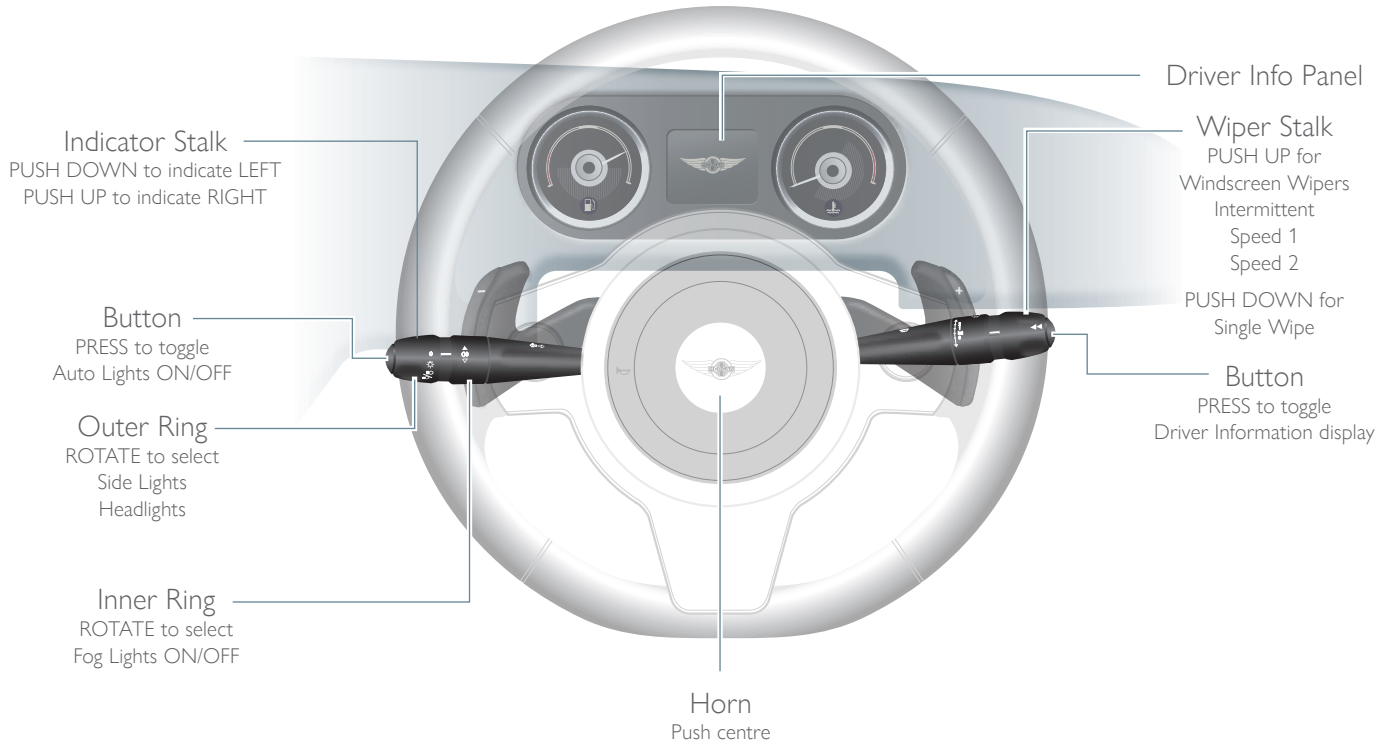

LIGHTS, INDICATORS AND WIPERS

Lights and Indicators

The lights and indicators are operated from the left hand stalk behind the steering wheel. This stalk includes an inner ring for fog lamps and an outer ring for driving lamps.

To indicate left, push the stalk in a downward direction. To indicate right, lift the stalk in an upward direction. The indicators are self-cancelling. To use the Lane Change function, press the lever as far as the resistance point; the turn signal indicators flash three times.

To select side lamps, rotate the outer end of the stalk to the first position. To select headlamps, rotate the outer ring of the stalk to the second position. To select high beam, push the stalk towards the steering wheel past the point of resistance. To select low beam, pull the stalk back towards the steering wheel past the point of resistance. To flash the headlamps lightly pull the stalk towards the steering wheel, then release.

If the vehicle is left with the stalk set to the side lamps or headlamps position, the vehicle will emit a sound to alert the driver that the lights have been left on.

To select fog lamps, rotate the inner stalk ring upwards. Headlamps must be on for the fog lamps to turn on.

Windscreen Wipers/Washers

The right hand stalk behind the steering wheel operates the wiper and washer system. To operate the wipers move the control upward.

- Position 1 Wipers Off
- Position 2 Intermittent Wipe
- Position 3 First Speed Continuous
- Position 4 Second Speed Continuous

Intermittent Wipe

With the main switch in the second position, the windscreen will be cleared after a pre-set delay.

Single Wipe

If the complete stalk is pressed downward, the windscreen will be swept once. The stalk will return automatically.

Windscreen Washers

To wash the windscreen, the stalk should be pulled towards the steering wheel. The stalk will return automatically. Each time the washer is operated, the wipers will sweep the windscreen four times.

 **WARNING** Always switch the wipers off before turning off the ignition.

 **WARNING** In frost or snow, always check that the wipers are free before operation. Not doing so will damage the wiper system.

 **WARNING** At all times use an additive in the windscreen washer system to prevent freezing.

 **WARNING** Do not use wipers on a dry screen.

Ignition Switch/Steering Lock

The ignition switch is located on the steering column and has 3 positions.

- 1st Position:** Steering wheel lock in operation and ignition off, key can be extracted in this position.
- 2nd Position:** Ignition switched on. Both the 12V socket and vehicle sound amplifier are on.
- 3rd Position:** In this position, press and hold the start button whilst pressing the brake pedal (automatic) or clutch pedal (manual) to start the engine.

⚠ WARNING Never allow the car to move unless the lock is deactivated. Failure to unlock the steering may result in an accident resulting in serious injury or even death.

Horn Button

The horn is located in the central padded section of the steering wheel, push firmly to operate.

DRIVING LIGHTS

Daytime Driving Lights

In some countries daytime driving lights are compulsory. Daytime driving lights come on automatically when ignition is on.

Side Lights

Rotate the indicator stalk outer ring to the  position.

CAUTION Do not leave the side lights on for long periods of time when the engine is not running. Doing so will discharge the battery and may leave insufficient power to allow the engine to be started.

Headlights - Low-beam/High-beam

Rotate the indicator stalk outer ring to position . Select between high and low-beam by pulling the Indicator stalk towards the steering wheel.

Auto Driving Lights

Depending on ambient brightness, the system switches the low-beam headlights on or off automatically. The headlights may also come on when the sun is setting low in the sky. The driving spot lights will function as part of the Auto Driving Lights.

To select Auto Driving Lights, the Indicator stalk outer ring should be set to switch position 0. Press the indicator stalk button to toggle the  icon on and off in the Driver Information Panel behind the steering wheel.

Rear Fog Lamp

Twisting the inner collar of the indicator stalk upwards turns on the rear fog lamp. When turned on, a symbol will display on the Driver Information Panel. The rear fog lamp will only operate when the vehicle lights are switched on.

NOTICE Do not use rear fog lamps in good weather conditions, use only when necessary.

TRANSMISSION MODES (AUTOMATIC GEARBOX)

⚠ WARNING An unsecured vehicle can start moving and rolling away. Danger of accidents. Before leaving the vehicle, secure it to prevent rolling away.

Apply the parking brake to ensure that the vehicle is secured against rolling away:

Selector Lever Positions (LHD Selector shown)

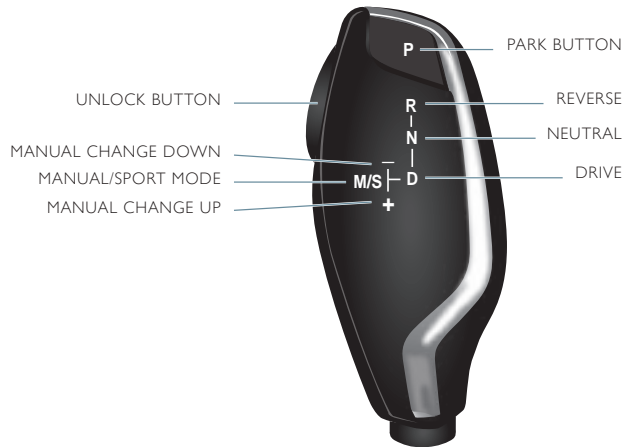

D DRIVE

Selector lever position for all normal driving. All gears for forward driving are selected automatically.

R REVERSE

Engage this position only when the vehicle is stationary.

N NEUTRAL, IDLING

In selector lever position N, neither Park, Reverse, Neutral or Drive modes are selected, allowing the vehicle to roll.

P PARK

Engage this position only when the vehicle is stationary. The drive gears are locked. Selector lever position P is automatically engaged in the following situations:

- After stopping the engine or ignition off when the selector lever position R or D is engaged.

Park mode should also be used in combination with the foot brake or handbrake.

Auto Park

Auto Park function prevents the vehicle from moving and activates if a door is open and seatbelt is disengaged or when the ignition is turned off.

ENGAGING DRIVE MODES (AUTOMATIC GEARBOX)

General

Apply the foot brake until ready to drive off; this will prevent the vehicle from moving when a gear is selected.

- It is possible to move from selector lever position P with the engine running and the brake pressed.
- Before shifting the selector lever position P or N when the vehicle is stationary, first press the foot brake, otherwise the shift lock will not be deactivated and the desired gearshift will not be performed.

Selector Lever Lock

A lock prevents inadvertently shifting to selector lever position R and inadvertently shifting from selector position P. To release the selector lever lock and engage a different lever position, press the button on the side Selector lever.

Engaging Selector Lever Positions D, N and R (Comfort)

With the driver's seat belt fastened, briefly press the selector lever in the desired direction, possibly overcoming a resistance point. When the selector lever is released, it returns to the central position.

Engaging Selector Lever Position P - Park (Comfort)

Press button P located at the top of the selector lever.



Selector Lever Lock. Press button. (LHD Selector shown)



Engaging Selector Lever positions D, N, R. (LHD Selector shown)

DRIVE MODES (AUTOMATIC GEARBOX)

Comfort, Sport & Sport+

By default the vehicle will start in Comfort, which delivers the most efficient shift programme. It is possible to also use the shift paddles to select higher or lower gears in Comfort Mode (see Shift Paddle section).

Activating Sport

When in the drive position (D) the selector lever may be moved (left) into the Sport position. This position is recommended for a performance driving style. In Sport there are two methods for manually shifting up or down a gear: Using the Selector Lever or the Shift Paddles.

In Sport Mode, pushing the selector gear lever forward or backward will activate manual gear shift up or down. The gear change is now manually controlled by the driver, pushing the gear lever forward will change down the gears and pulling the gear lever back will change up the gears. When in Sport Mode, the gear selected appears briefly on the Driver Information panel.

Selecting gears in Sport Mode using the gear selector (Automatic Gearbox):

To shift down: Push the selector lever forwards.

To shift up: Pull the selector lever backwards.

When in Sport Mode, gears can also be selected by operating the Shift Paddles (See next page)



Park button. (LHD Selector shown)



Activating Manual Operation. (LHD Selector shown)

Selecting gears in Sport Mode using the Shift Paddles (Automatic Gearbox):

Shift paddles on the steering column enable fast gear shifting without taking hands off the steering wheel.

To shift down: Pull the left Shift Paddle briefly towards the steering wheel.

To shift up: Pull the right Shift Paddle briefly towards the steering wheel.

To return to automatic shift in Sport Mode, hold the left hand paddle for approximately 3 seconds.

To return to standard Comfort Mode (auto) move the gear lever right to engage Comfort Mode and the vehicle will continue in automatic.

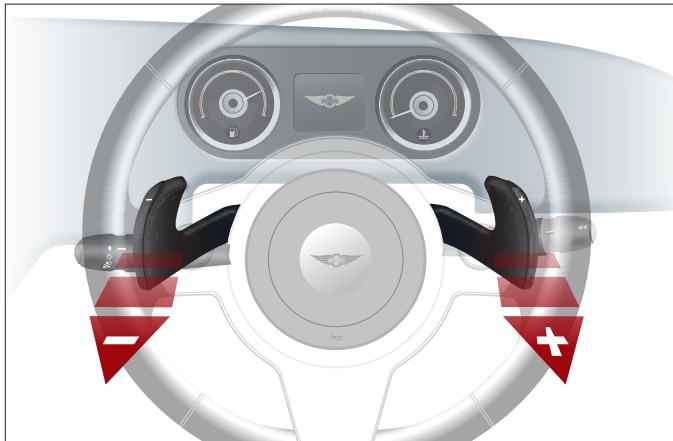

Gearshift Paddles Pull the left paddle to shift down a gear, pull the right paddle to shift up a gear.

General

The Drive and Shift programmes will avoid gear shifts that may cause mechanical harm. For example, a manual down shift would not be allowed if the engine speed is deemed too high.

The gear selected appears briefly in the Driver Instrument Panel, followed by the gear currently in use.

If the driver shifts gear with the shift paddles on the steering wheel whilst in Comfort Mode, the vehicle will revert back to comfort mode after a period of moderate driving. The selector lever position is displayed in the Driver Information Panel.

DRIVE MODES (MANUAL GEARBOX)

Selecting gears using the Manual Gear Lever:

The gear positions are laid out in the standard H type pattern with reverse gear located to the left and then forwards. When in neutral the gear lever will naturally sit between 3rd and 4th gear.

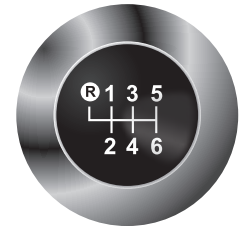

When engaging reverse gear ensure the vehicle is stationary and the clutch pedal is fully depressed.

Move the gear lever fully to the left and then apply pressure until the lever moves further left past a resistance point before pushing forward to engage the reverse gear.

Activating Sport+

Sport+ enables a more aggressive throttle response. To engage Sport+ Mode, press the S+ button for at least one second on the tunnel next to the Gear Lever. Continue to use manual gear selection as normal. To disengage Sport+ Mode, press the S+ button again to return to Comfort Mode.

UNDER DASHBOARD FUNCTIONS

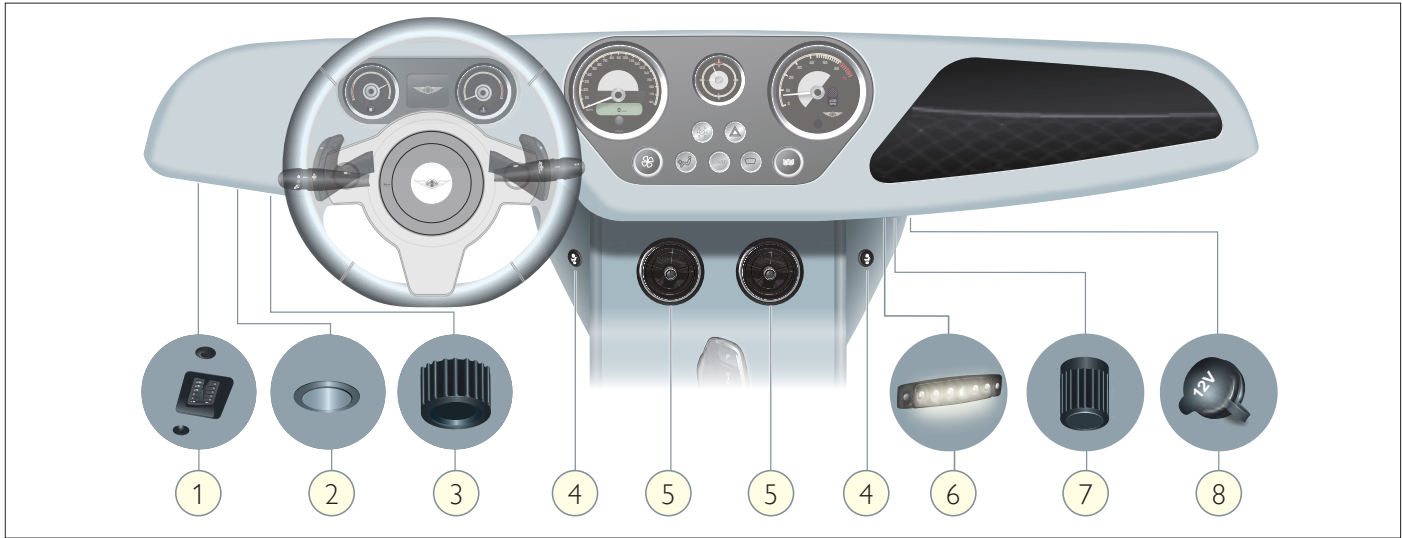

1. Diagnostic Socket
2. Overseer Switch
3. Instrument Dimmer Switch
4. Heated Seat Switches
5. Front Heater Vents
5. Front Heater Vents
4. Footwell Lights
6. Footwell Lights
7. Volume Control
8. 12V Electric Socket

Diagnostic Socket ⁽¹⁾

Diagnostic socket for connecting to and interfacing with the Morgan Plus Four's electronic systems. It is recommended that this is only performed by an authorised Morgan dealership.

Overseer Switch (Automatic Vehicles Only) ⁽²⁾

⚠ WARNING Do not disable the overseer for driving on public roads.

⚠ WARNING The Overseer system is not a driver aid, stability, or traction control system.

The overseer is a safety feature that detects locking of the rear wheels. In such an event the overseer will place the gearbox into neutral. This feature can be deactivated at the driver's risk if potential rear wheel lock-up is considered acceptable. **This is not advisable on public roads under any circumstance.**

With the ignition on, or engine running, pressing the overseer button for 3 seconds will disable the rear wheel lockup detection. When the overseer is disabled, the amber overseer icon (OS) will display in the Driver Information Panel. The overseer automatically re-engages after the ignition is switched off.

Instrument Dimmer Switch ⁽³⁾

This switch controls the brightness of the instrument lighting. Rotate the knurled knob anti-clockwise to increase brightness.

Volume Control Button ⁽⁷⁾

Rotate to increase or decrease the volume from a connected audio device.

Heated Seat Switches ⁽⁴⁾

Situated either side of the gearbox tunnel, each switch controls the temperature in nearest seat. Pads in the seat heat up when this button is switched on. The heated seats have two setting levels on the switch. Level 1 is indicated by a green LED, level 2 is indicated by a red LED. The heated seats automatically switch off when the ignition is turned off.

Front Heater Vents ⁽⁵⁾

The direction of airflow can be adjusted by moving the whole vent using the central knob. Twist the central knob clockwise to shut off air flow, rotate the central knob anti-clockwise to open air flow.

Footwell Lights ⁽⁶⁾

Footwell lights come on when the doors are opened and will fade after 30 seconds if no other actions take place. When the ignition is turned on, the lights will fade.

12 Volt Socket ⁽⁸⁾

Located under the passenger side of the dashboard. With the cap removed, power leads with the correct adapter can be used to power phones or other equipment. The socket is active in accessory and ignition key positions.

Bluetooth® Module

The **Bluetooth®** streaming module allows music playback from a **Bluetooth®** compatible device (e.g. smartphone or tablet).

To pair your device, turn the ignition key, enable **Bluetooth®** on your device. The Morgan vehicle will appear in the list of available devices as “MusicStream” or “Morgan”. The pairing process only needs to be performed once per device. Play audio using your device and it will be heard through the vehicle speakers. The playback volume can be adjusted using the knob under the dashboard as well as the volume control on the device itself.

NOTE: The system does not provide hands free calling operation.

 **WARNING** Mobile devices should not be operated when the vehicle is in motion. Please observe the relevant region-specific laws on the use of mobile devices in vehicles.

DRIVING CONTROLS - FOOT CONTROLS

The foot pedals in the vehicles are set out in the standard format with the accelerator pedal on the right, brake pedal in the centre and the clutch pedal (Manual only) on the left hand side.

 **WARNING** When driving, suitable footwear should be worn. Wearing incorrect or no footwear may inhibit your ability to operate the foot pedals resulting in an accident. It is essential that all foot pedals are free of obstructions that may interfere with their operation.

Foot Brake

Allow the brake system to fully bed in before heavy braking is performed unless in an emergency or other cases when heavy braking is required. The required pedal effort will be reduced as the brake system beds in.

⚠ WARNING The brake system on your Morgan Plus Four is a servo-assisted system. Braking assistance is only supplied whilst the engine is running. Do not coast with the engine off. This may result in a loss of brake performance resulting in an accident causing serious injury or even death.

Accelerator

The accelerator on your Morgan Plus Four is an electronically operated accelerator system.

NOTICE Do not push the accelerator pedal when starting the vehicle.

Clutch Pedal (Manual Only)

NOTICE Do not slip or hold the car on the clutch for more than a few moments. Excessive slipping or holding the car on the clutch when on a slope will cause wear and damage to the clutch system.

NOTICE Ensure the clutch is fully depressed when changing gear. Failure to do so may result in damage to the transmission system.

NOTICE Do not rest your foot on the clutch pedal whilst driving.

DRIVING CONTROLS - HAND OPERATED CONTROLS

Handbrake

The handbrake on the Morgan Plus Four only operates the rear wheel brakes. The handbrake lever is a conventional type handbrake. Pull the lever upwards until the brake begins to operate and holds the vehicle in a stationary position securely.

To release the handbrake push the button on the end of the lever and slowly release the lever ensuring that the vehicle will not move or roll unless required.

Ensure the handbrake is fully released before driving the vehicle. Failure to do so may result in damage to the brake system and drive-train components.

NOTICE When the vehicle is stationary the handbrake should be fully engaged and the automatic gearbox selector set to Park.

Steering Column Adjustment

It is important to have the steering controls in the correct position for the driver. The steering column in the Morgan Plus Four can be adjusted up or down and forwards or backwards. To move the steering wheel into the desired position push the lever at the left side of the steering column downward. The steering column is now free to be moved into the desired position. Once set in the desired position pull the lever firmly back up into the locking position to ensure the steering column is firmly secured.

⚠ WARNING Only adjust the steering column position when the vehicle is in Park and the hand brake is applied. Failure to do this may result in an accident causing possible damage or injury to the driver or others.

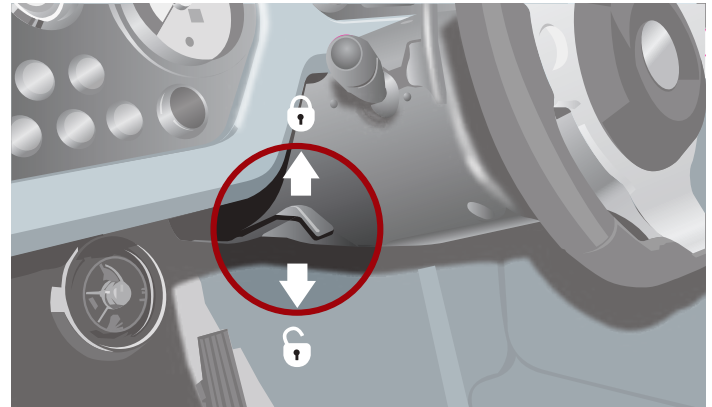

Location of the Steering Column Adjustment Locking Lever.

HEATING, VENTILATION AND AC

Air Conditioning (AC)

The Air Conditioning system on the Morgan Plus Four is switched on using the push switch located on the instrument panel. The AC button lights up when activated. In order for the AC to operate the engine must be running. To have refrigerated air supplied to the cabin turn the temperature control to the cold setting with the AC switched on. To supply dehumidified air to the cabin, have the temperature control turned to a warm setting with AC switched on. Conditioned air is supplied to the cabin via the outlets in the heater unit.

Temperature Control

To control the temperature of the air being supplied to the cabin, rotate the knob located on the instrument panel. Turn the knob clockwise to increase the temperature of the supplied air and anti-clockwise to reduce the temperature of the supplied air. When Temperature Control is activated an icon will appear for a few seconds in the Driver Information Panel.

Fan Speed

A rotating knob, located on the instrument panel, controls the rate at which air is supplied to the cabin. Rotate anti-clockwise to stop/reduce the flow of air, rotate clockwise to start/increase the flow of air.

Ventilation Distribution

The direction of air being supplied to the cabin is controlled using the vents located centrally under the dashboard and in the footwells. The under dashboard vents can be angled to control the direction of the air and can be shut off to prevent air ventilation coming into the cabin from the heater unit. To activate air ventilation into the footwells, press the Footwell Vent Switch on the dashboard.

STARTING PROCEDURE

Before attempting to start the car, make certain that the handbrake is fully applied.

Do not operate the accelerator pedal when starting the engine. Turn the key and ensure that the ignition/steering lock is free.

Never allow the car to move with the steering lock engaged.

To start the Morgan Plus Four, turn the key to the second position and press the Start button once to turn on the ignition. Once the ignition is on, depress the brake pedal and press and hold the start button to start the engine. Release the button as soon as the engine is running.

If the engine still fails to start, switch off the ignition and consult your nearest Morgan dealer.

NOTICE Continued operation of the starter will discharge the battery and damage the starter.

 **WARNING** Carbon Monoxide is dangerous. Do not breathe exhaust gases, which contain Carbon Monoxide. Before starting any car, be sure that there is sufficient ventilation to allow gases to escape.

Warming Up

As soon as the engine is running and the instruments are reading correctly, the car may be driven. The tick-over will be adjusted by the fuel injection and may run a little higher than normal while the engine is cold. The idle speed is adjusted by the engine ECU and may run a little higher than normal when the engine is cold.

NOTICE Avoid harsh acceleration or labouring at all times, but especially when the engine is cold. It is recommended that the car be driven carefully until the normal running temperature is reached.

HOOD DOWN PROCEDURE

⚠ WARNING To prevent damage to the hood, ensure it is clean before folding. Pay particular attention to the rear window panel which should be completely free from trapped dirt and debris before folding to prevent scratches occurring.

⚠ WARNING Avoid folding or unfolding the rear window in very cold conditions. This may cause the rear window panel to split.

⚠ WARNING The hood mechanism has several moving parts that can cause injury. Avoid trapping hands, fingers or loose clothing in the mechanism while operating the roof.

⚠ WARNING Care should be taken in the assembly/disassembly and storage of the hood/hood cover to avoid damage to the vehicle and hood components. It is therefore recommended that these procedures are carried out by two people.



INSIDE: Locate the rear hood rail release lever next to the drivers seat. Pull the lever, releasing the tension in the hood and disconnecting the rear rail from the vehicle body.

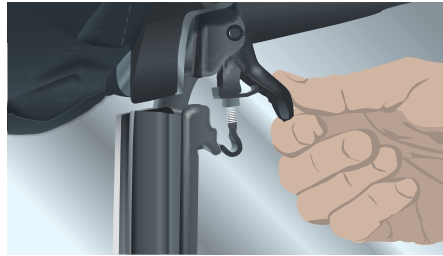

INSIDE: Release the front rail catches by pushing down on the release button and hinging the lever upwards to disconnect the clamp from the windscreen pillar.

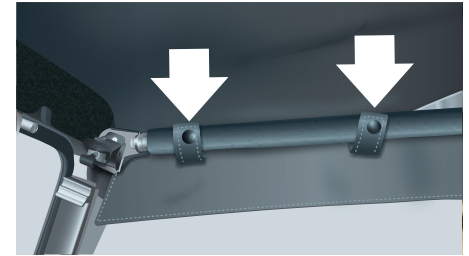

INSIDE: Locate the two press studs holding the roof fabric to each of the side rails. Release the press studs, allowing the straps to hang loosely.

HOOD DOWN PROCEDURE (CONT.)

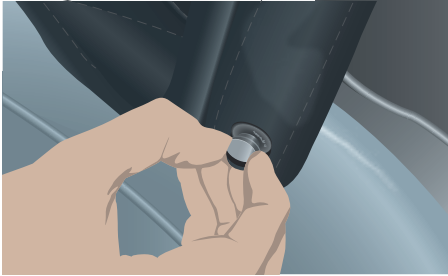

⚠ WARNING Failure to release the press studs before lowering the hood can damage the vehicle body work.

The press studs are behind the trailing edge of the doors. Lift the outer ring and pull to release the side of the hood from the vehicle.

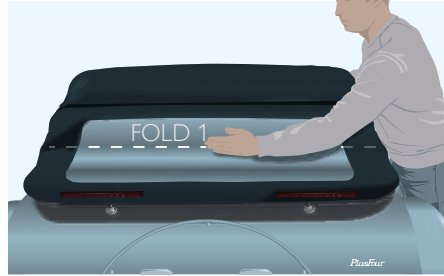

Begin lifting the hood from the front rail. Carefully make a neat fold through the rear window panel.

⚠ WARNING Ensure the high level brake light is not covered by the fabric from the hood.



Continue to tilt the hood backwards while making a second fold between the window and roof section. Lower the roof fully onto itself, making a third fold. The main roof fabric should be pulled backwards over the tail as the roof frame folds down to avoid the scissor action of the mechanism.

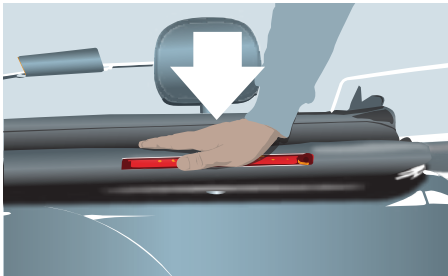

Make sure both sprung catches are properly aligned with their holes at the rear of the vehicle. Push down vigorously over each spring catch to lock in place.

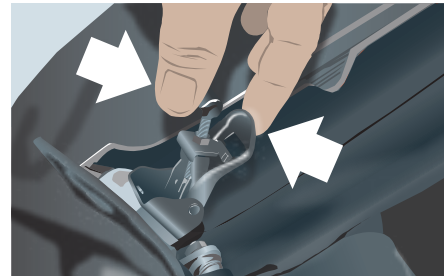

Locate the front rail lock/release clamps and squeeze the clamp and outer lever together.

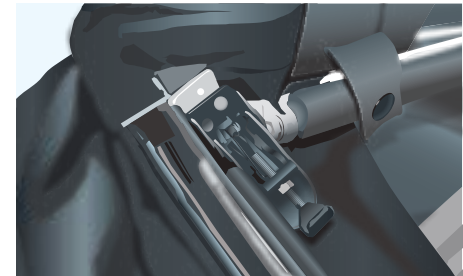

Lay the clamps flat.

HOOD COVER FITTING PROCEDURE

To avoid potential damage to the vehicle, it is recommended that two people perform the following procedure:



INSIDE: Ensure the hood is folded down. Pull the rear hood rail release lever next to the drivers seat. The rear hood rail is released from the back of the vehicle.



Have a helper lift and support the rear hood rail.



Slide the hood cover under the rail, passing the rear spring catches through the two holes in the hood cover. Note the press studs should be passed under the rail to align inside the vehicle, behind the seats.



Snap closed all press studs, including those behind the seats. Push down on the back rail to lock into place. Remove in reverse order.

- ⚠ WARNING** Avoid scratching paintwork with the press studs.
- ⚠ WARNING** The hood mechanism has several moving parts that can cause injury. Avoid trapping hands, fingers or loose clothing in the mechanism while putting up or taking down the hood.
- ⚠ WARNING** It is not recommended to attempt hood and/or hood cover procedures alone.

HOOD UP PROCEDURE - To avoid potential damage to the vehicle, it is recommended that two people perform the following procedure:



Remove hood cover if fitted (see Hood cover fitting).



INSIDE: Locate the rear hood rail release lever next to the drivers seat. Pull the lever to release the rear hood rail from the body.

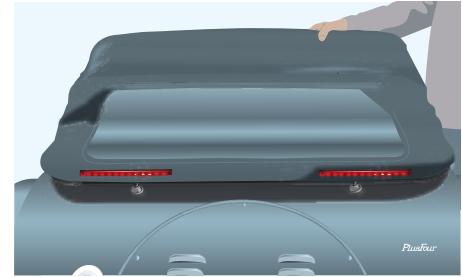

Carefully unfold the hood, positioning the front rail on top of the windscreen.

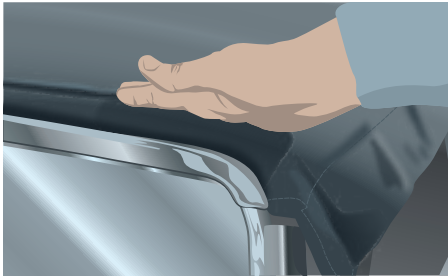

Push down on the corners of the front rail to ensure correct alignment with the windscreen.

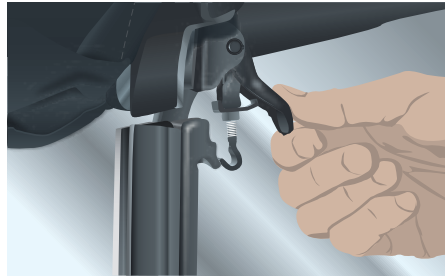

INSIDE: Open out the front hood clamps to engage the hook into the windscreen pillars.

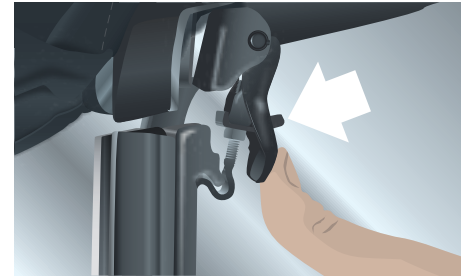

Engage the hook into the pillar and clamp down with the lever. Ensure the release button (arrowed) is fully out.

HOOD UP PROCEDURE - CONT.

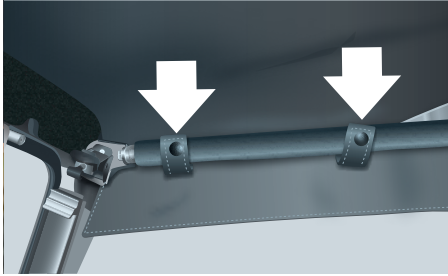

INSIDE: Attach the press studs to the side rails.

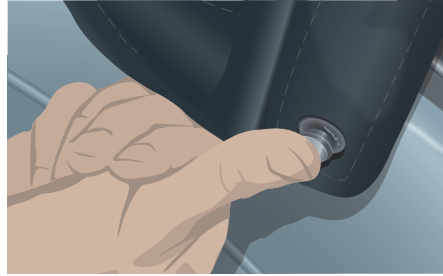

Secure the lower sides of the hood by pushing in the press studs either side of the vehicle.

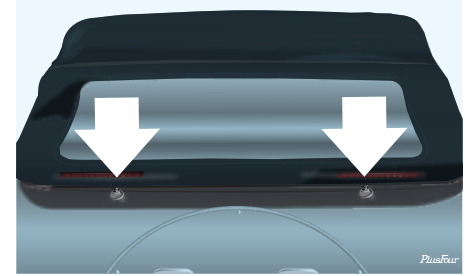

Push down on the rear hood rail over the clamping points to secure from the rear and provide the required tension through the hood.

FUEL FILLING

The Morgan Plus Four must be fuelled with unleaded gasoline fuel. The Morgan Plus Four will run satisfactorily on gasoline of a minimum octane rating of 95 RON. Using fuel with a lower octane rating may cause knocking (pinking) that in severe cases can cause damage to the engine and its components.

⚠ WARNING Using the incorrect fuel in the vehicle may cause damage to the vehicle's engine and emission control components. Damage caused to the vehicle as a result of the use of improper fuel is not covered by the manufacturer's warranty.

The fuel filler cap is located on the rear of the vehicle. Pull up the hinged tab then rotate it anticlockwise by a quarter turn. Pull out the cap. A security strap prevents the cap from falling.

⚠ WARNING When removing the filler cap do so slowly. Failure to do this may result in fuel spray causing serious injury and a fire hazard.

⚠ WARNING Care must be taken not to damage the paint work of the Plus Four. Lay the filler cap down carefully against the outer filler ring.

⚠ WARNING Do not attempt to over fill the tank after the auto-shut off has stopped the pump.

After filling with fuel, reverse the procedure to seal the fuel tank.

⚠ WARNING Failure to properly seal the fuel filler cap may result in the vehicles emission system not operating correctly causing the engine check light to come on.

⚠ WARNING Petrol and its fumes are highly flammable. When filling the vehicle with fuel ensure the engine is turned off, switch off mobile phones and ensure there are no naked flames or other potential ignition sources present.

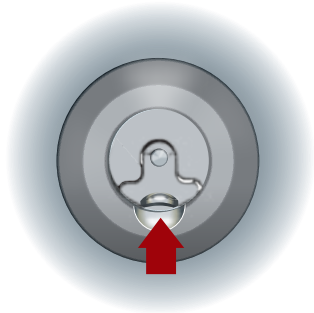

Locate lift tab

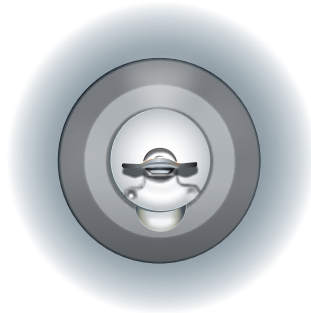

Lift up tab

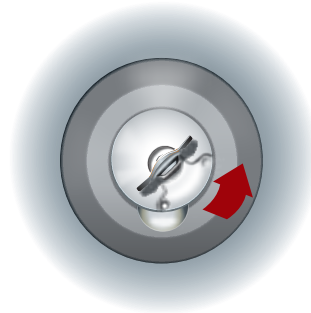

Rotate anti-clockwise



Pull out

OPENING AND CLOSING THE BONNETS

To open the bonnets on your Morgan Plus Four first slide the retaining round handle on the rear bonnet latch down and pull outwards. Repeat the operation on the front retaining latch and then lift the bonnet upwards. To close the bonnet push down and inwards on the bonnet latches.

NOTICE Always take care when opening bonnets in windy weather conditions. The wind may cause bonnets to fall down causing serious injury to yourself or others.

NOTICE Only open one bonnet at a time; opening both bonnets at the same time may cause damage to the bonnets.

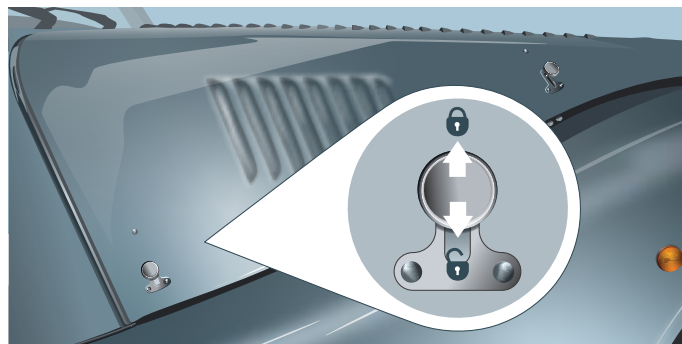

PUTTING UP THE BONNET STAY

The bonnet stay on your Morgan Plus Four is located inside the bonnet. To put up the bonnet using the bonnet stay, place one end of the bonnet stay through the lower bracket and the other end through the top bracket on the bonnet itself.

NOTICE Take extra care to avoid scratching paint and engine components with the bonnet stay.

NOTICE Always check the bonnet is supported by the bonnet stay fully before letting go of the bonnet.

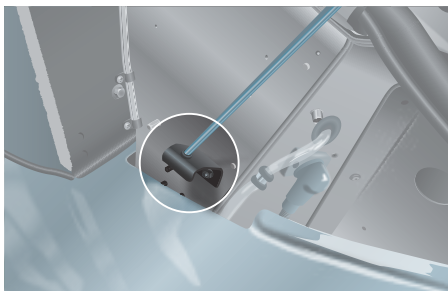
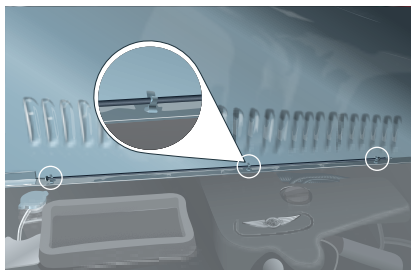

TYRES

Glossary of Terms

Cold Tyre Inflation Pressure

Check and adjust tyre pressures when the tyres are cold, the car must have been stationary for 3 hours or driven less than 1 mile.

Recommended Inflation Pressure

The cold tyre inflation pressure is stated on the tyre and loading placard, located on the door threshold plate.

Maximum Inflation Pressure

The maximum inflation pressure of the tyres must not exceed the cold tyre inflation pressure.

Cold Tyre Inflation Pressure

Morgan recommend that the tyres should be inflated to 28psi/193kPa. This information can also be found on the vehicles Tyre Placard Label under the left bonnet on the inner A-post panel.

To measure and adjust the tyres remove the dust caps from the valves on the wheels and connect the measuring/inflation device. Follow the instruction supplied with the measuring/adjusting device to measure/adjust the tyre pressures. When you have finished remove the measuring/adjusting device and refit the dust caps to the valve.

⚠ WARNING Tyres should be regularly inspected for any signs of damage, and for any uneven tread wear. Uneven tread wear may indicate that the suspension system may require attention from a Morgan Service Agent.

⚠ WARNING Take care when parking to avoid tyre contact with kerbs.

⚠ WARNING Contact with the kerb can cause internal damage to the tyre that may not be visibly apparent. Damage may also be caused if the tyre strikes potholes, rocks or other highway debris.

⚠ WARNING If the wheels or tyres have been damaged, have them replaced.

⚠ WARNING Tyres must be replaced when the legal tread depth limits are approached.

⚠ WARNING Poorly maintained and improperly used tyres are dangerous and may cause an accident resulting in serious injury or even death.

⚠ WARNING Tyres must not exceed their loading limits. Overloading of tyres can cause blowouts resulting in accidents causing serious injury or even death. See 'Tyre Placard Label'.

⚠ WARNING Tyres must be inflated to the correct pressures. Over or under inflated tyres can cause blowouts resulting in accidents causing serious injury or even death. See 'Tyre Placard Label'.

⚠ WARNING Tyres matching the correct manufacturers specification must be used. Using incorrect tyres can affect the handling of the vehicle, which can cause an accident resulting in serious injury or even death.

Tyre Care

Wear indicators are moulded into the bottom of the tread grooves at intervals around the tyre, indicated by small pointers on the outer tread blocks. The tyres should be replaced before being worn to the minimum legal tread depth. The cold tyre pressures should be checked every week, or every 1,000 miles (1,600 km), whichever is the sooner, and corrections made as necessary. See 'Wheels & Tyres' at the front of the handbook for tyre pressures. It is important that the

tyre pressures are adjusted only when the Tyres are cold (when the car has been standing for a minimum of 3 hours, or driven less than 1 mile). Always replace the tyre valve dust cap to prevent dirt and moisture getting into the valve, which could cause leakage.

Replacement Tyres and Tyre Quality Grading

The tyre quality grade can be found on the tyre sidewall, indicating the quality of performance of the tyre. For example:

TREADWEAR 230 TRACTION AA TEMPERATURE A

Treadwear

The Treadwear grade is a comparative rating based on the wear rate of the tyre when tested under controlled conditions on a specified government test course. For example, a tyre graded 150 would wear one and one-half (1½) times as well on the government course as a tyre graded 100. The relative performance of tyres depends upon the actual conditions of their use, however, and may depart significantly from normal due to variations in driving habits, service practices and differences in road characteristics and climate.



Traction

The traction grades, from highest to lowest, are AA, A, B, and C. Those grades represent the tyre's ability to stop on a wet pavement as measured under controlled conditions on specified government test surfaces of asphalt and concrete. A tyre marked as grade C may have poor traction performance.

⚠ WARNING The traction grade assigned to this tyre is based on straight-ahead braking traction tests, and does not include acceleration, cornering, hydroplaning, or peak traction characteristics.

Temperature

The temperature grades are A (the highest), B, and C, representing the tyre's resistance to the generation of heat and its ability to dissipate heat when tested under controlled conditions on a specified indoor laboratory test wheel. Sustained high temperature can cause the material of the tyre to degenerate and reduce tyre life, and excessive temperature can lead to sudden tyre failure. The grade C corresponds to a level of performance, which all passenger car tyres must meet. Grades B and A represent higher levels of performance on the laboratory test wheel than the minimum required by law.

⚠ WARNING The temperature grade for this tyre is established for a tyre that is properly inflated and not overloaded. Excessive speed, under inflation, or excessive loading, either separately or in combination, can cause heat build-up and possible tyre failure.

The factory-fitted 15" or 16" tyres on the vehicle are developed using high performance compounds which become brittle at low temperatures and therefore should not be used in certain conditions. These tyres should be stored or used only at temperatures at or above minus 10°C (14° F) to maintain performance characteristics and avoid damage to the tyre or injury to persons or property.

Tyre Identification Number (TIN)

Marked on the sidewall of the tyre is the TIN; this is made up of 5 sections. Starting with DOT, then a 2-digit manufacturers code, then a 2-digit tyre size code, then a 3-digit construction code finishing with a 4-digit month and year code.



Tyre Size Markings

On the sidewall of the tyre will be marked the tyre size, for example:

205/60R15 91V



205 is the nominal width of the tyre in mm, 60 is the height of the cross section of the tyre expressed as a percentage of the width, R is the tyre construction in this case radial, 15 is the rim diameter in inches, 91 is the tyre load index and V is the tyre speed rating.

Tyre Placard/Label

The tyre and loading information label is located under the left bonnet on the inner A-post panel. It specifies the correct size and pressure of tyres to be used on the Morgan Plus Four.

VIN (Vehicle Identification Number) Plate

The Vehicle Identification Number Plate is positioned under the left bonnet on the inner A-post panel.

Gross Vehicle Weight Rating

⚠ WARNING Do not exceed the GVWR (Gross Vehicle Weight Rating), or front or rear GAWR (Gross Axle Weight Rating). Exceeding these limits may cause unstable handling or car or tyre damage, which could cause a crash in which the driver or others could be seriously injured or killed. The vehicles GVWR can be found next to VIN plate positioned under the left bonnet on the inner A-post panel.

⚠ WARNING The Morgan Plus Four must never be used to tow a trailer.

Changing a Wheel

Wheels should be changed at a Morgan dealership where the vehicle can be raised using specialist equipment.

In an emergency, a jack may be used to raise the vehicle sufficiently to clear a trapped obstacle from underneath. See 'LIFTING THE VEHICLE.'

Flat Tyre (Emergency Tyre Repair)

In the event of sustaining a flat tyre, contact your nearest Morgan dealer or a vehicle recovery company. If your vehicle carries a puncture repair kit, follow the instructions with the kit.

MAIN FUSE BOX

Replacing Fuses

The main fusebox is located behind the passenger footrest at the end of the footwell. To access the main fuse box, locate the top edge of the carpet trim and pull it free folding the carpet back into the footwell. Behind the carpet is an aluminium plate secured by two fasteners. The fuse box is behind this plate. Release the fasteners and lift the plate up to clear the locating tab at its base. Use the fuse layout schematic below to identify a blown fuse, pull it out and replace it with a spare fuse of the same rating.

⚠ WARNING Never make modifications or additions to the electrical circuit or components on your Morgan Plus Four. Carefully replace blown fuses. See table on the rear of the lid for the main fusebox for correct fuse rating for each circuit.

⚠ WARNING Working with electricity is dangerous unless conducted by an expert.

BATTERY

The Morgan Plus Four uses a "maintenance free" battery which is located under the bonnet on the passenger side of the vehicle. If the battery is required to be removed from the vehicle this should normally be performed by a Morgan dealer. Whenever the battery requires removal/refitting, the terminals should be cleaned and covered in petroleum jelly.

The battery will discharge gradually if the vehicle is not used. If the vehicle is left standing for more than 2 weeks then it is advised that a battery conditioner is used to maintain the battery correctly. If a battery is allowed to discharge fully this will damage the battery leading to failure and this will not be covered on the vehicle's warranty.

⚠ WARNING Batteries contain acid based liquids; avoid contact with skin, eyes or clothing. If battery acid is in contact with the skin or eyes flush with copious amounts of water. Remove contaminated clothes immediately. Seek medical attention. If ingested do not induce vomiting or ingest any fluids, seek immediate medical attention.

⚠ WARNING Batteries produce explosive gases; keep isolated from potential ignition sources.

⚠ WARNING Ensure battery terminals are always isolated.

⚠ WARNING Observe all warnings as shown on the battery.

⚠ WARNING Always disconnect the battery when working on a vehicle.

⚠ WARNING Never short circuit a battery, short-circuiting a battery may result in serious burns.

BATTERY REMOVAL

If the battery is required to be removed from the vehicle this should normally be performed by a Morgan dealer.

To remove the battery, locate the negative terminal on the top of the battery (2). It has a minus (-) symbol stamped into the rubber cover. Pull back the cover to reveal the terminal post and clamp. Loosen the clamp, pull it off the battery post and carefully secure the lead to prevent it springing back and reconnecting with the post.

Locate the positive terminal on top of the battery (1). It has a plus symbol (+) stamped into the rubber cover. Pull back the cover to reveal the terminal post and clamp. Loosen the clamp, pull it off the battery post and carefully secure the lead to prevent it springing back and reconnecting with the post.

Locate the battery securing clamp (3). Loosen the nut on the clamp sufficiently to allow the end of the J-shaped rod to be unhooked. With sufficient clearance, the complete clamping assembly can be disconnected. Carefully lift the clamp assembly, along with the electrical leads fastened to it and ease the cables towards the front of the vehicle until sufficient clearance is obtained to safely remove the battery.

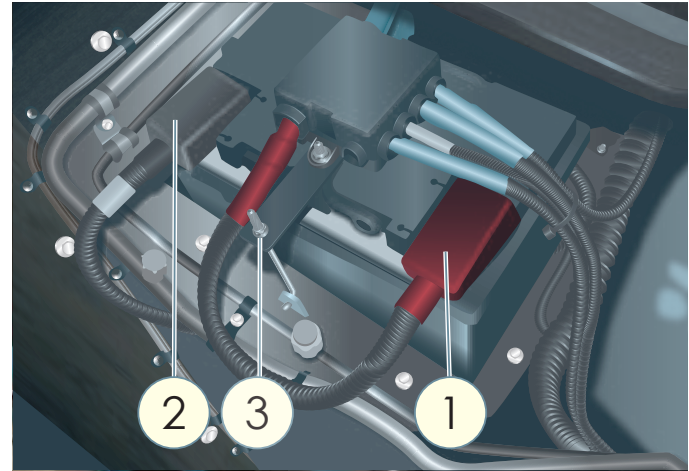

JUMP STARTING

To jump start the Morgan Plus Four, connect the positive jump starting power supply first to the positive terminal on the battery. Connect the negative terminal of the jump starting power supply to a good earth on the chassis or battery.

NOTICE Great care must be taken to avoid short-circuits when jump-starting a vehicle.

⚠ WARNING Not connecting jump-starting cables correctly may result in damage to a vehicle's electrical system.

TOWING

The Morgan Plus Four must not be towed behind another vehicle. If for any reason the car needs to be transported using means other than the vehicle's engine it should be done using an appropriate car transporter. If this is not an option then the car should be towed with the drive wheels (rear) off the ground.

⚠ WARNING Towing the Morgan Plus Four with the drive wheels on the ground will cause damage to the transmission system.

NOTICE: It is always best whenever possible to transport a vehicle using car transporters rather than towing a vehicle. When moving a vehicle using car transporters secure the vehicle using wheel chocks and wheel tie down straps. Do not secure the vehicle using the towing loop, bodywork or suspension components.

Towing Trailers

The Morgan Plus Four is not designed for use as a towing vehicle for either towing trailers or other vehicles.

⚠ WARNING Do not use a Morgan Plus Four to tow trailers or any other vehicles.

Moving the Vehicle When the Engine Cannot Start (Automatic Gearbox)

If your car is fitted with an automatic gearbox and the engine cannot be started, the gearbox will be locked, preventing the vehicle from being pushed or rolled, for example, onto an appropriate car transporter. To unlock the gearbox, the neutral lever on the gearbox must be engaged using the tool provided in the tool kit to operate the release mechanism.



Tool for putting the gearbox lever into the neutral position.

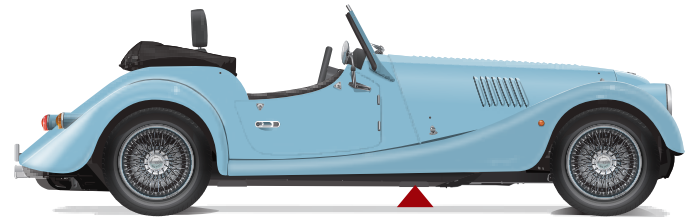

1. Locate the square hole in the undertray to access the gearbox lever. This is in-line with the front jacking point (marked with a red arrow) on the left side of the vehicle.

NOTICE: If your vehicle does not have a square hole cut in the undertray to access the lever on the gearbox, please call either your nearest Morgan Dealership or Roadside Assistance.

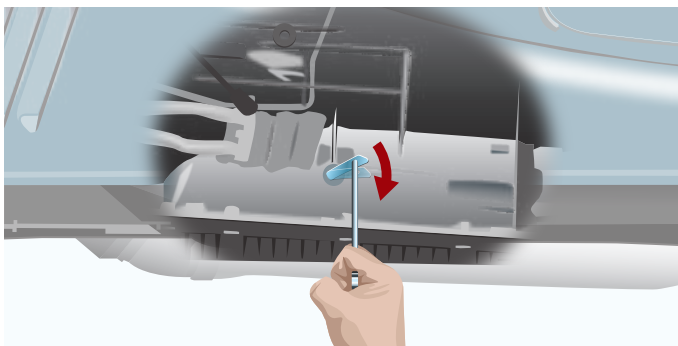

2. Push the J-shaped rod through the undertray with the hook facing the gearbox, towards the middle of the vehicle. Locate the hook into a hole in the gearbox lever by lining up the bottom of the slot in the tool with the bottom of the undertray. The hook is correctly located in the hole when the tool will freely hang.

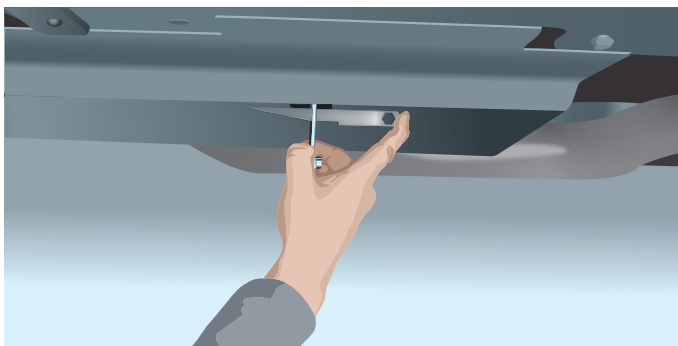

3. With the flat face of the drift in contact with the undertray, push the drift part of the tool through the slot in the J-shaped rod to pull down the lever. When the tool is fully engaged, the vehicle will now freely roll.

LIFTING THE VEHICLE

It is recommended that the vehicle is only lifted using a professional workshop post lift or hydraulic ramp. Wheels should be changed at a Morgan dealership where the vehicle can be raised using specialist equipment. In an emergency, a jack may be used to raise the vehicle sufficiently to clear a trapped obstacle from underneath.

NOTICE: Care should be taken not to damage the brake pipes, wiring or any other components. Care should be taken to avoid burns if the exhaust is hot.

- ⚠ WARNING** Lifting a vehicle when using a jack can be dangerous. If the vehicle falls off the jack at any time you or others may be seriously injured or even killed.
- ⚠ WARNING** Never lift a car when the engine is running.
- ⚠ WARNING** Before lifting the vehicle, ensure the road wheels in contact with the ground are suitably chocked and the handbrake is engaged.
- ⚠ WARNING** If using a jack, only lift the vehicle at the reinforced jacking points (illustrated, red arrows) on the chassis. If using a garage post lift, position the front support arms further forward under the chassis leg (amber arrows).

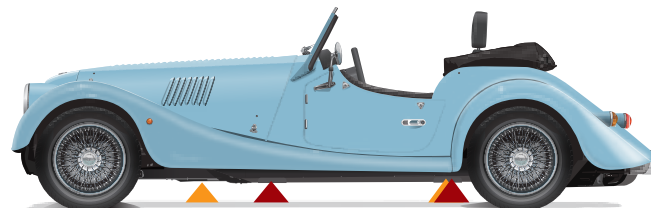

Red arrows: Reinforced jacking points on the chassis. Amber arrows: Position for post lift support arms.

MAINTENANCE CHECKS

In this section will be found information necessary to maintain the car in good mechanical condition in a temperate climate. Details of the intervals of service may be found in the schedule at the back of this book. The time between examinations is dependent on many things, particularly the type of use and the road conditions. In dusty, extreme, or arduous conditions, the time between services must be reduced. If a car is not in use for long periods the need for regular attention is as great as for a vehicle in everyday use. The following details, along with services from a Morgan distributor or dealer, will help to prolong the life and enjoyment of the car.

Daily Checks

- Lights
- Horn
- Indicators
- Windscreen wipers and washers
- Mirrors
- Brakes operation (foot and hand)

Weekly Checks (or before long journeys)

- Engine Oil Level
- Engine Coolant Level
- Washer Bottle Level
- Brake Fluid
- Tyre Pressures and Condition
- Lubricate all locks and hinges (including bonnet hinge)

Electronic Oil Measurement

The engine oil level is electronically monitored when travelling and shown in the Driver Information panel. If the engine oil level reaches a minimum, a check control message is shown.

The engine must be left to rest for around 30 minutes in order for the electronic oil measurement feature to be used. With a shorter journey, the status of the last sufficiently long journey is shown. When frequently making short trips, regularly take a detailed measurement.

Adding Engine Oil

⚠ WARNING Danger of injury from hot engine.

Only top up a quantity of 1 litre (approximately 2 pints) of engine oil when the message on the driver information display is shown or the engine oil level has dropped to the lower marking. Stop and apply the handbrake. Switch off the ignition. Allow the engine to cool. Locate the oil filler cap positioned on the top of the engine, under the right bonnet. Open the oil filler cap by turning anticlockwise. Add engine oil. Ensure not to overfill with too much engine oil. Clean up any oil spillage on the cover plate.

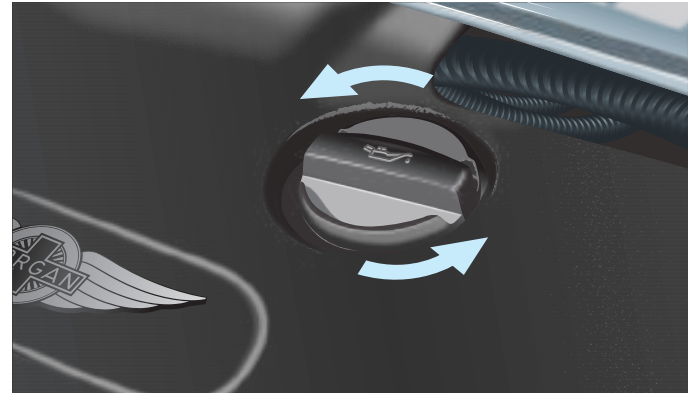

Oil Filler Cap located under the right bonnet.

Suitable Engine Oil Grade

It is recommended that only genuine BMW specification engine oils are used in a Morgan Plus Four. Engine oils with the following oil specification can be used to top up if required:

ACEA A2/B2 or ACEA A2/B3 or ACEA A3/B3 Fully Synthetic engine oil of the highest possible quality. Viscosity Class **SAE 5W-30**.

Oil Change

⚠ WARNING Engine oil not replaced in time can lead to increased engine wear and / or engine damage. Do not exceed the service date indicated. Morgan recommends having the engine oil changed by a certified Morgan Dealership or specialist workshop.

The engine oil should be changed every 10,000 miles or annually. Run the engine to normal temperature. Switch off the engine and remove drain plug from the sump. When the oil has drained completely, clean and replace the plug with a new plug gasket. Fit a new oil filter and fill with 5.25 litres (1.4 US Gal) of the correct grade and quantity of oil. Replace the filler cap on the rocker cover and run the engine for a short while. Take an oil level reading. The level should be on the 4/4 or 5/4 mark. If the reading is below the 4/4 mark, top up with appropriate oil (see Suitable Engine Oil Grade). For every 1/4 mark below 4/4 add 0.25 litre of engine oil.

⚠ WARNING Never over-fill an engine with oil.

⚠ WARNING Care should be taken when draining engine oil, as it may be very hot.

⚠ WARNING Prolonged exposure to used engine oil can cause serious skin disorders. Avoid excessive contact with skin or use protection.

⚠ WARNING The radiator fan may operate even when the ignition is switched off. Take care not to work near the fan until the engine has cooled sufficiently.

Oil Filter

The Morgan Plus Four uses a replaceable oil filter element located in the middle of the left-hand side of the engine which should always be replaced when the engine oil is changed.

To remove the filter, unscrew the filter cover anti clockwise and carefully withdraw from the vehicle taking care to catch any dripping oil. Install the new filter into the housing on the side of the engine noting its correct orientation. Remove the old seal from the filter cover and clean off any old engine oil, fit a new seal and lightly lubricate with clean engine oil. Screw the cover on clockwise until fully seated taking care not to over tighten.

Gearbox

The transmission system is permanently filled. The transmission oil level should be checked by a Morgan Service Dealer during routine servicing.

Air Cleaner

The injection system fitted to this car detects the level of air drawn into the engine, and uses this information to control the fuel level. It is most important that the airflow is not restricted. The air cleaner should be changed every 10,000 miles, or more frequently in dusty conditions or regular town use. A Morgan Service Dealer should change the air filter element as it is only accessible from underneath the vehicle. When replacing, use the correct specification of element.

Spark Plugs

The spark plugs should be checked every 10,000 miles for the correct gap. The electrode and body should be cleaned and examined for damage. If the plug shows any sign of damage or deposits it must be replaced. When fitting new spark plugs be sure only the correct specification is used and the gap correctly set.

Cooling System

The coolant expansion tanks and coolant systems are situated under the bonnet. Under the left hand bonnet is the engine coolant circuit and under the right hand bonnet is the low temperature intercooler circuit. Both coolant systems should be filled to half way up the tank with HT-12 coolant and should be inspected only when the engine is cool. It is essential that the engine is supplied with sufficient water/HT-12 mixture at all times. In an engine of this type, HT-12 must be present in the water at all times. HT-12 should be kept at a minimum of 50% by volume.

⚠ WARNING Only remove the coolant filler cap when the engine is cool, otherwise the escaping steam and boiling water may cause serious scalding and injury.

⚠ WARNING Coolant fluids are dangerous; keep out of reach of children. Swallowing coolant may damage health resulting in death or serious damage to the body.

Whenever the car is serviced and periodically between these times, the coolant must be checked. At the same time it is recommended that all the hose clips and hoses be examined for tightness and damage. Any persistent loss of coolant should be indicated to a Morgan service agent at the earliest opportunity.

NOTICE: When the expansion tank is filled above half, water would be discharged through the clear overflow pipe on the neck of the expansion tank when the engine is hot.

Electric Fans

Two electric fans are positioned behind the radiator and an auxiliary fan in front. These are operated by a temperature switch in the engine and controlled by the ECU. The fan speed will automatically vary to maintain the correct engine temperature. As the temperature rises in traffic, the fans will then cut in and cut out. If there is any doubt about the operation of the fan system, consult a Morgan Dealer.

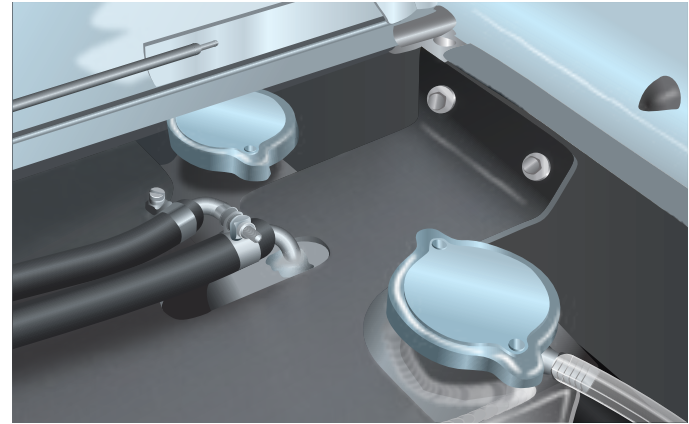

Engine Coolant Expansion Tanks

⚠ WARNING Do not allow tools, hands or clothing to come into contact with the fans. Fans may operate without warning, even with the ignition switched off!

Windscreen Washer

The Windscreen washer bottle filler is located under the left hand bonnet. Pull off the filler cap, top up with windscreen cleaner then refit the filler cap. In cold weather it is recommended to use an antifreeze and windscreen cleaner, to prevent freezing and aid cleaning.

NOTICE: Do not use engine coolant antifreeze, only specially prepared solutions for washer systems. Follow manufacturer's instructions carefully.

Brakes

⚠ WARNING The importance of brake maintenance cannot be over-stressed. The owner is legally required to keep the braking system to a satisfactory performance level. Brake pads and linings must be renewed in axle sets. Failure to do so will seriously affect the operation of the system.

⚠ WARNING Any drop in reservoir fluid level or operation standards must be reported immediately to a dealer.

⚠ WARNING Never make modifications to the braking system. Trained personnel must carry out changes. It is recommended that a qualified engineer or Morgan service agent should carry out all repairs and brake services.

⚠ WARNING Care must be taken when handling brake fluid, as it may cause skin problems. Follow manufacturers instructions carefully.

⚠ WARNING Use only new brake fluid.

⚠ WARNING Never leave fluid exposed to the air, as it will absorb moisture.

⚠ WARNING Brake fluid will damage paint and other finished surfaces.

⚠ WARNING Use only the recommended brake fluid or equivalents.

⚠ WARNING This car is fitted with servo-assisted brakes. DO NOT move the car without the engine running, as the effort required will be greatly increased. The car will stop if the pedal is pressed hard enough.

Brake Fluid Reservoir

The brake fluid reservoir is situated under the right hand bonnet on RHD vehicles and under the left hand bonnet on LHD vehicles.

Every 5,000 miles (8,000km) remove the cover and check fluid level in the reservoir. There is a minimum and maximum level mark on the rear of the reservoir, the fluid should be filled to the maximum mark. If necessary replenish using a funnel and flexible hose to within ½" (12mm) of the top with DOT 4 Brake Fluid. Replace cover ensuring that the rubber-sealing ring is in good condition and that the ventilation hole is unblocked. If significant topping-up is required check the master cylinder, slave cylinders and pipes for leakage, any leakage must be rectified immediately.

The brake fluid in the system must be drained and replaced every 2 years.

The brakes will be inspected regularly during a normal service. Cleanliness is essential when dealing with brakes as grease or oil cannot be removed from brake linings. Always replace brake parts with genuine Morgan original specification components.

⚠ WARNING Brake fluid is hazardous and will cause illness or even death if swallowed.

⚠ WARNING Use only the specified brake fluid; using the incorrect fluid may cause damage to the brake system.

⚠ WARNING Using incorrect brake components or excessively worn components will affect your braking system and may result in an accident causing serious injury or even death.

VIN Number, Paint Codes and Weights

The VIN (Vehicle Identification) number, paint codes and weights can be found under the left side bonnet: stamped either directly into the vehicle structure or onto a plate to the side of and below the battery.

CLEANING

Polishing

It is recommended that the paintwork should not be treated with a heavy wax for a period of three months after the car has been painted. This will allow the paintwork to 'breathe' and cure correctly. During this time the car should be cleaned regularly and may be treated with a light polish. The bright work should be cleaned and waxed every time the car is cleaned.

After this initial period, the surface of the paintwork should be thoroughly cleaned. Any imperfections, such as light scratches, should be removed using a fine rubbing compound applied with a soft cloth.

NOTICE Polishing compounds must be used carefully as they actually remove the paint surface. A fine cutting polish can be used to polish road film off the paint surface.

Do not use cutting polishes that contain ammonia as this may bleach some pigments. After you are happy that the paint is completely clean, a good quality wax polish should be used to finish off. You should avoid silicone-based products and polymer sealers, as these can prevent the paint from 'breathing'. Use a traditional wax polish which may require a little more effort, but the result is worth it. After the initial polishing of the car, it is most important to keep the paintwork and chrome work clean and well waxed.

NOTICE Be sure not to get polish or oil on the brakes when cleaning. Your dealer will be happy to provide advice about the best materials to use when cleaning your car.

Interior

Standard leather may be cleaned using a damp clean cloth.

 **WARNING** Excessive direct sun light, heat and exposure to moisture will cause damage to interior materials and specifically to the leather used in your car.

MIRRORS

Your Morgan Plus Four is fitted with two door mounted and one windscreen mounted rear view mirror. To adjust the door mirrors move the mirrors on the stalks until they are in the desired position.

NOTICE Never force the movement of the mirrors, this may cause damage to the mirrors or their mounting surfaces.



WARRANTY INFORMATION

When the vehicle needs warranty repairs it should be taken to any MORGAN authorised service dealer. Please note, a small number of Morgan service only outlets are not able to provide aftersales care for CX-Generation Morgan vehicles including your Morgan Plus Four. Please consult your service agent for further information.

If there are questions or concerns with the vehicle, we suggest these steps are followed:

1. Contact a Service Advisor at an authorised Service Dealer.
2. If the inquiry or concern remains unresolved, contact the Dealer principle.
3. If the inquiry or concern cannot be resolved, please contact the Morgan Customer Assistance Department at:

Morgan Motor Company Limited
Pickersleigh Road, Malvern,
Worcestershire, England WR14 1AJ

Customer Assistance telephone: +44(0) 1684 573104
(This is a UK-based telephone number)

This section explains in detail the warranties that apply to your Morgan Plus Four:

KNOW WHEN YOUR WARRANTY BEGINS

The Warranty Start Date (for all warranties) is the day the first retail owner takes delivery of the new vehicle, or the day it is first put into service (for example, as a demonstrator), whichever occurs first. Alternative dates can only be set by Morgan Motor Company and must be done so in writing.

CHECK THE VEHICLE

We check vehicles carefully at the factory to assure quality. Upon delivery, check the vehicle over carefully and if there is any damage or problems, notify your supplying dealer immediately.

MAINTAIN THE VEHICLE PROPERLY

Proper maintenance protects against major repair expenses resulting from neglect or inadequate maintenance. It is the owner's responsibility to make sure that all of the scheduled maintenance is performed within 1 month or 1,000 miles and that the materials used meet Morgan specifications. Failure to perform scheduled maintenance as specified in the Scheduled Maintenance Guide will invalidate warranty coverage on parts affected by the lack of maintenance. Make sure that confirmation of maintenance work is kept.

WHO PAYS FOR WARRANTY REPAIRS?

The owner will not be charged for qualifying warranty repairs during the warranty period for the New Vehicle Limited Warranty or Emissions Warranty. Sometimes Morgan may offer a special adjustment programme to pay all or part of the cost of certain repairs beyond the terms of the applicable warranty. Check with the Morgan Customer Assistance Centre to learn whether any adjustment programme is applicable to the vehicle. Please have the vehicle identification number available.

The Morgan Motor Company New Vehicle Limited Warranty

The New Vehicle Limited Warranty is the only express warranty applicable to your vehicle. Morgan does not assume nor authorise anyone to assume for it any other obligation or liability in connection with your vehicle or this warranty.

MORGAN is not responsible for any time that you lose, for any inconvenience you might be caused, for the loss of your transportation, or for any other incidental or consequential damages you may have. You may also have some implied warranties.

For example, you may have:

- An implied warranty of merchantability (that the car is reasonably fit for the general purpose for which it was sold) or...
- An implied warranty of fitness for a particular purpose (that the car is suitable for your special purposes).

These implied warranties are limited, to the extent allowed by law, to the time period covered by the New Vehicle Limited Warranty, or to the applicable time period provided by state law, whichever period is shorter.

What is Covered Under the New Vehicle Limited Warranty?

Your warranty covers you for one year, or 12,000 miles free recovery service (organised by your supplying dealer for markets outside the UK).

During this coverage period, the authorised Morgan service point will repair, replace, or adjust all parts on your vehicle that are defective in factory-supplied materials or workmanship. Items and conditions that are not covered by the New Vehicle Limited Warranty are described below. When making warranty repairs on your vehicle, the authorised service point will use genuine Morgan new or re-manufactured parts, or other parts that are authorised by Morgan.

What is Not Covered?

Damage Caused By:

- Accidents, collision or objects striking the vehicle.
- Acts of theft, vandalism, war, riot, fire or explosion.
- Freezing.
- Misuse of the vehicle, such as speeding, driving over curbs, overloading.
- Altering or modifying the vehicle – including the engine, body, chassis, or components – after the vehicle leaves Morgan’s control.
- Non-MORGAN parts installed after the vehicle leaves Morgan’s control. (For example, but not limited to, cellular phones, alarm systems.)

- Tampering with the vehicle, tampering its emissions systems, or with other parts that affect these systems.
- Disconnecting or altering the odometer or allowing the odometer to be inoperative for an extended period of time with the result that the actual mileage cannot be determined.
- Using contaminated or improper fuel/fluids.
- Customer-applied chemicals or accidental spills.
- Driving through water deep enough to cause the ingress of water into the engine or control systems.
- Driving on unreasonable road surfaces such as closed roads, circuits or race tracks or driving in excess of legal speed limits for extended periods.
- Use in racing or timed competitive events or by parts sold as “off road” or “competition-only” parts.

Damage Caused by Use and/or the Environment

Your New Vehicle Limited Warranty does not cover surface rust and deterioration of paint, trim, upholstery, and other appearance items that result from use and/or exposure to the elements.

Here are examples:

- Stone chips, scratches (some examples are on paint and glass)
- Dents and other panel damage
- Cuts, burns, punctures or tears
- Road salt, tree sap
- Bird droppings
- Lightning, hail
- Windstorm
- Earthquake
- Water or flood
- Normal interior ageing

Damage Caused by Improper Maintenance

Your New Vehicle Limited Warranty does not cover damage caused by failure to maintain the vehicle, improperly servicing or maintaining the vehicle, or using the wrong part, fuel, oil, lubricants, or fluids.

Maintenance/Wear and Tear

Your New Vehicle Limited Warranty does not cover: (1) parts and labour needed to maintain the vehicle; and (2) the replacement of parts due to normal wear and tear. You, as the owner, are responsible for these items.

Here are examples:

- Oil changes
- Oils, lubricants, other fluids
- Oil/air filters
- Brake linings/pads
- Tyre rotation or balancing
- Cleaning/polishing
- Wiper blades
- Clutch linings
- Engine tune-up
- Bulbs
- Belts
- Hoses
- Wheel alignment

Other Items and Conditions Not Covered

Your New Vehicle Limited Warranty also does not cover:

- Any vehicle to which the warranty does not apply as described in section 2, above.
- Minor wind noise or water ingress or normal vehicle noises or vibrations.
- Non-Morgan engine parts; for example, parts installed by modifiers, or damage to original components caused by installation of such non-Morgan, other than “certified” emissions parts.
- Vehicles that have ever been labelled or branded as “dismantled”, “fire”, “flood”, “junk”, “rebuilt”, “reconstructed”, or “salvaged”; this will void the New Vehicle Limited Warranty.
- Vehicles that have been determined to be a “total loss” by an insurance company; this will void the New Vehicle Limited Warranty.
- Tyres, sound systems, batteries.
- Incidental and consequential damage, as explained above.

Warranties on Tyres, Sound Systems and Batteries

The tyre, sound system, and battery manufacturers provide you with separate warranties. You will find these warranties with the owner literature supplied with your new vehicle. Morgan provides no warranty coverage on these items.

However, if a tyre, sound system or battery is damaged during the New Vehicle Limited Warranty coverage period because of a vehicle defect in factory-supplied materials or workmanship, Morgan will replace the tyre, sound system component or battery.

SCHEDULED MAINTENANCE GUIDE

General Maintenance Information

This guide describes the scheduled maintenance required for your vehicle. Carefully following this schedule helps protect against major repair expenses resulting from neglect or inadequate maintenance. It is your responsibility to see that all scheduled maintenance is performed and that the materials used meet engineering specifications. Failure to perform scheduled maintenance specified in this guide will invalidate warranty coverage on parts affected by the lack of maintenance. Be sure confirmation of the work performed is always kept. Your authorised service point has factory-trained technicians who can perform the required maintenance using genuine parts. To assure the proper performance of your vehicle and its emission control systems, scheduled maintenance must be completed at the designated intervals. Engine parts other than Morgan new or re-manufactured parts that are used for maintenance replacement or for the service of components must be equivalent to genuine Morgan part in performance and durability. It is the owner’s responsibility to assure the equivalency of such parts.

Which Maintenance Schedule Should You Follow?

SPECIAL OPERATING CONDITIONS

If the vehicle is operated in any of the more demanding “Special Operating Conditions” listed below, some items will need to be maintained more frequently. If the vehicle is only occasionally operated under these conditions, it is not necessary to perform the additional maintenance.

For specific recommendations contact the Morgan Customer Assistance Centre:

- Extensive idling and/or driving at low speeds for long distances
- Driving in dusty conditions

NORMAL SCHEDULE

The Normal Schedule applies to those who operate their vehicle under typical, everyday driving conditions. The maintenance frequency represented in the normal schedule typifies what most vehicle operators will require.

Every 10,000 miles or annually:

Replace engine oil and filter

Every 10,000 miles or annually:

Replace air filter

Annually:

Inspect brake system

Every two years:

Replace brake fluid

Every 60,000 miles or 5 years:

Replace spark plugs

Special Operating Conditions

EXTENSIVE IDLING AND / OR LOW-SPEED DRIVING FOR LONG DISTANCES AND OPERATION IN DUSTY CONDITIONS SUCH AS UNPAVED OR DUSTY ROADS:

Every 6,000 miles or 9 months:

Replace engine oil and filter

As required:

Replace engine air filter

Owner Checks and Services

(Refer to Mileage Intervals for Additional Checks and Services)

The owner or a service technician should perform certain basic maintenance checks and inspections at the intervals indicated. The owner maintenance service checks are generally not covered by warranties so the owner may be charged for labour, parts or lubricants used.

Check At Least Every Month:

- Check function of all interior and exterior lights
- Check tyres for wear and proper air pressure
- Check engine oil fluid level
- Check windscreen washer solvent fluid level
- Check lap/shoulder belts and seat latches for wear and function
- Check washer spray, wiper operation, and clean all wiper blades
- Check handbrake for proper operation
- Check and lubricate all hinges, latches and outside locks
- Check and lubricate door rubber weather-strips
- Check safety-warning lamps (brake, safety belt) for operation
- Check cooling system fluid level and coolant strength
- Check battery connections and clean if necessary

Normal Maintenance Schedule

The following section contains the "Normal Schedule".

This schedule is presented at specific mileage intervals with exceptions noted.

If you require repair and maintenance information not covered in this handbook please contact your **Morgan dealer** or **DSC@Morgan-Motor.co.uk**



MORGAN PLUS FOUR 3 MONTHS COURTESY CHECK (OPTIONAL)

3 months after delivery

Checked by:.....



Dealer Stamp



Name:

Address:
.....
.....
.....

Date:

Mileage:

Signature:



MORGAN PLUS FOUR 1ST SERVICE

10,000 miles (16,000km) or 12 months after delivery (whichever comes first.)

RENEW OIL

OIL FILTER

AIR FILTER

SPARK PLUG

Serviced by:



Dealer Stamp



Name:

Address:

.....

.....

.....

Date:

Mileage:

Signature:



MORGAN PLUS FOUR 2ND SERVICE

20,000 miles (32,000km) or 24 months after delivery (whichever comes first.)

RENEW OIL

OIL FILTER

AIR FILTER

SPARK PLUG

Serviced by:



Dealer Stamp



Name:

Address:

.....

.....

.....

Date:

Mileage:

Signature:



MORGAN PLUS FOUR 4TH SERVICE

30,000 miles (48,000km) or 36 months after delivery (whichever comes first.)

RENEW OIL

OIL FILTER

AIR FILTER

SPARK PLUG

Serviced by:



Dealer Stamp



Name:

Address:

.....

.....

.....

Date:

Mileage:

Signature:



MORGAN PLUS FOUR 5TH SERVICE

40,000 miles (64,000km) or 48 months after delivery (whichever comes first.)

RENEW OIL

OIL FILTER

AIR FILTER

SPARK PLUG

Serviced by:



Dealer Stamp



Name:

Address:

.....

.....

.....

Date:

Mileage:

Signature:



MORGAN PLUS FOUR 6TH SERVICE

50,000 miles (80,000km) or 60 months after delivery (whichever comes first.)

RENEW OIL

OIL FILTER

AIR FILTER

SPARK PLUG

Serviced by:



Dealer Stamp



Name:

Address:

.....

.....

.....

Date:

Mileage:

Signature:



MORGAN PLUS FOUR 7TH SERVICE

60,000 miles (96,000km) or 72 months after delivery (whichever comes first.)

RENEW OIL

OIL FILTER

AIR FILTER

SPARK PLUG

Serviced by:



Dealer Stamp



Name:

Address:

.....

.....

.....

Date:

Mileage:

Signature:



MORGAN PLUS FOUR 8TH SERVICE

70,000 miles (112,000km) or 84 months after delivery (whichever comes first.)

RENEW OIL

OIL FILTER

AIR FILTER

SPARK PLUG

Serviced by:



Dealer Stamp



Name:

Address:

.....

.....

.....

Date:

Mileage:

Signature:



MORGAN PLUS FOUR 9TH SERVICE

80,000 miles (128,000km) or 96 months after delivery (whichever comes first.)

RENEW OIL

OIL FILTER

AIR FILTER

SPARK PLUG

Serviced by:



Dealer Stamp



Name:

Address:

.....

.....

.....

Date:

Mileage:

Signature:



MORGAN PLUS FOUR 10TH SERVICE

90,000 miles (145,000km) or 108 months after delivery (whichever comes first.)

RENEW OIL

OIL FILTER

AIR FILTER

SPARK PLUG

Serviced by:



Dealer Stamp



Name:

Address:

.....

.....

.....

Date:

Mileage:

Signature:





INDEX

3 Months Courtesy Check.....	57	Comfort Mode.....	26	Engine Oil Change.....	47	Heated Windscreen.....	15
Accelerator Pedal	30	Contents.....	1	Engine Oil Grade.....	47	Heater Fan Contro.....	14
Adding Engine Oil.....	46	Control Stalks.....	21	Engine Oil Level.....	19	Heater Vents.....	29
Air Bags	11	Cooling System.....	48	Engine Start.....	14	Heating	31
Air Cleaner	47	Cooling System Information.....	4	Expansion Tanks.....	48	Hood	32
Air Conditioning	14, 31	Customer Assistance Department.....	52	Fans, Engine Bay.....	48	Hood Colour.....	3
Air Conditioning Information.....	4	Damage Caused by Improper		Fan Speed.....	31	Hood Cover Fitting Procedure.....	34
Amber Warning Symbols.....	20	Maintenance.....	54	Flat Tyre	42	Hood Down Procedure.....	32
Auto Lights.....	18, 23	Damage Caused by Use		Fog Lamp.....	15, 23	Hood Up Procedure.....	35
Auto Park.....	24	and/or the Environment.....	53	Foot Brake	29	Horn	21, 23
Battery	42	Dashboard.....	12, 13, 16, 28	Foot Controls.....	29	Icon Explanation.....	17
Battery Removal.....	43	Daytime Driving Lights	23	Footwell Lights.....	29	Ignition	14
Bluetooth® Streaming Module.....	29	Dealer Information.....	3	Footwell Vent.....	14	Ignition Switch.....	23
Body Colour.....	3	Diagnostic Socket.....	28	Fuel Consumption.....	5	Ignition System Information.....	4
Bonnets	38	Dimensions.....	5	Fuel Filling.....	37	Indicators.....	22
Bonnet Stay.....	38	Dimmer Switch.....	29	Fuel Level Gauge.....	15	Indicator Stalk.....	21
Brake Fluid Reservoir	49	Door Locks.....	9	Fuel System Information	4	Infant passengers.....	11
Brakes	5	Drive Modes.....	25, 27	Fuse Box.....	42	Instrument Dimmer Switch.....	29
Brakes, Maintenance.....	49	Driver Information Panel.....	16, 17	Gearbox Into Neutral Tool.....	44	Instruments and Switches.....	12, 13
Capacities.....	4	Driving Controls.....	29, 30	Gearbox Oil	47	Intermittent Wipers.....	21
Carbon Dioxide Emissions.....	5	Electrical Equipment.....	8	Gear Lever.....	27	Jacking Points.....	45
Changing a Wheel.....	42	Electric Fans.....	48	Gear Ratios.....	4	Jump Starting.....	44
Chassis Information.....	5	Electronic Oil Measurement	46	Gross Vehicle Weight Rating.....	42	Keys	9
Check Message Warning Symbol.....	20	Emergency Tyre Repair.....	42	Handbrake.....	30	Lifting the vehicle.....	45
Children	11	Emissions	5	Hand Operated Controls.....	30	Lights	22, 23
Cleaning	50	Engine Coolant Expansion Tanks.....	48	Harmful Substances	8	Maintenance Checks.....	46
Clock	14	Engine Coolant Temperature.....	15	Hazard Warning Switch.....	14	Maintenance Guide.....	54
Clutch Pedal.....	30	Engine Immobiliser.....	9	Headlights.....	23		
Cold Tyre Inflation Pressure.....	39	Engine Information.....	4	Heated Seat Switches	29		
		Engine Oil.....	46				

Manual Gear Lever.....	27	Seat Belts.....	8, 10	Tyre Placard/Label.....	42
Mirrors	50	Seats	9	Tyres	39
Moving the Vehicle When the Engine Cannot Start.....	44	Selector Lever Lock.....	25	Tyre Size Markings.....	41
MPG or L/Km.....	18	Selector Lever Positions.....	24, 25	Under Dashboard Functions.....	28
MPH or KPH.....	18	Service Information.....	57	Vehicle Identification Number (VIN)	42, 50
New Vehicle Limited Warranty.....	52	Shift Paddles.....	27	Ventilation.....	31
Odometer.....	14	Side Lights.....	23	Ventilation Distribution.....	31
Oil and Fluid Specifications.....	4	Spark Plugs.....	47	Volume Control Button.....	29
Oil Change.....	47	Speedometer.....	14	Warming Up.....	31
Oil Filler Cap.....	46	Sport+ Mode.....	26, 27	Warning Icon Explanation	17
Oil Filter	47	Sport Mode.....	26	Warning Symbols.....	20
Oil Level Measurement	19	Starting Procedure.....	31	Warranty Information.....	52
Oil Measurement (Engine).....	46	Steering Column Adjustment.....	30	Warranty Start Date.....	3, 52
Opening and Closing the Bonnets.....	38	Steering Lock.....	23	Welcome.....	2
Outside Temperature.....	20	Suspension Information.....	5	Wheels and Tyres Information.....	5
Overseer Switch.....	28	Switches	12, 13	Windscreen Washer	48
Paint Colour Code.....	3	Symbol Explanation.....	17	Windscreen Wipers/Washers	22
Polishing	50	Tachometer	14	Wipers	22
Rear Fog Lamp.....	15, 23	Technical Information.....	4	Wiper Stalk.....	21
Rear View Mirror.....	50	Temperature.....	20		
Registration.....	3	Temperature Control.....	15, 31		
Remote Central Locking Key.....	9	Temperature - Tyres.....	40		
Replacement Tyres.....	40	Towing	44		
Replacing Fuses.....	42	Towing Trailers.....	44		
Rev Limit Warning Light.....	15	Traction	40		
Safety Information.....	7	Transmission Information.....	4		
Safety Restraints.....	9	Transmission Modes.....	24		
Scheduled Maintenance Guide.....	54	Treadwear	40		
		Trim Colour.....	3		
		Trip Meter	14		
		Trip Reset Button.....	14		
		Tyre Identification Number (TIN).....	41		
		Tyre Inflation Pressure	39		





MORGAN MOTOR COMPANY

Pickersleigh Road, Malvern Link, Worcestershire, England, WR14 2LL.

www.morgan-motor.com

Part No. GP011003