

Chapter 1

Operation of Instrumentation and Control Systems

— Overview of instrument panel

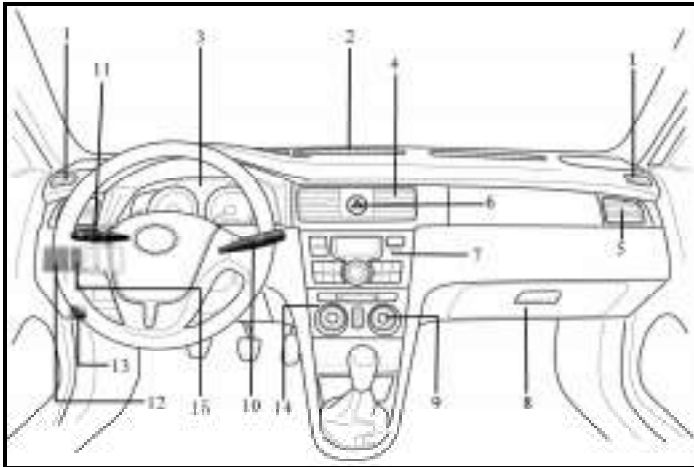





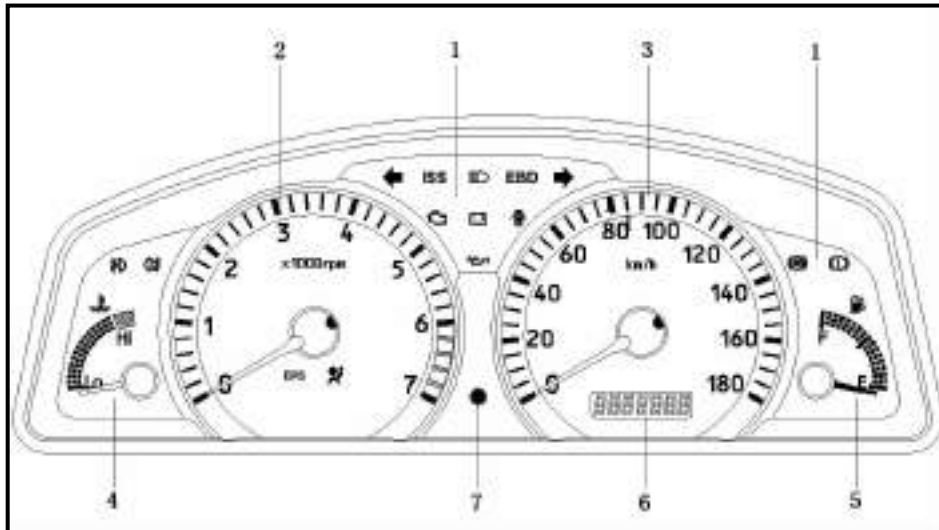





1. Air vent for defroster (defogger) of front window glass
2. Air vent for defroster (defogger) of front windshield
3. Combination instrument
4. Central air vent
5. Side air vent
6. Switch of emergency warning lamp
7. Car stereo
8. Glove compartment
9. Switch of rear defroster
10. Switch of wiper and washer
11. Switch of headlamp and turning lamp
12. Adjusting button for rear power mirror (if equipped with it)
13. Handle for opening engine hatch
14. Control knob for air conditioner

—Combination meter



- 1. Warning lamp and indicating lamp for fault
- 2. Tachometer
- 3. Speedometer
- 4. Water thermometer
- 5. Fuel gauge
- 6. Odometer and trip odometer
- 7. Reset button of trip odometer

—Symbols on instrument panel display

	Warning lamp for braking system*		Turning lamp
	Warning lamp for charging system *		Indicating lamp for high beam of headlamp
	Warning lamp for lower oil pressure*		Indicating lamp for operating rear fog light
	Warning lamp for engine fault *	EPS	Warning lamp for fault of power boost steering system * (if equipped)
	Warning lamp for automatic anti-lock braking system * (if equipped)		Warning lamp for air bag* (if equipped)
	Warning lamp for opening the door *	EBD	Warning lamp for electronic brake-force distribution system * (if equipped)

The symbol with “*” is used to remind the driver that the automobile needs to be maintained. Please see 1-5 “Warning lamp and indicating lamp” for details.

— Keys

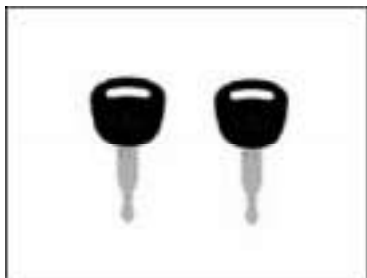

The doors may be locked without the key, thus, you need to take a spare key with you just in case of inconvenience when the key is locked in the car.

— Doors

How to open the door

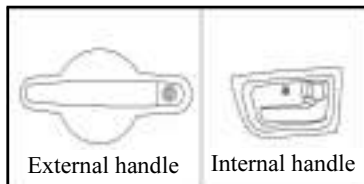

You may open the door by pulling the external handle from outside of the car or pulling the internal handle from inside of the car, when the doors are not locked.

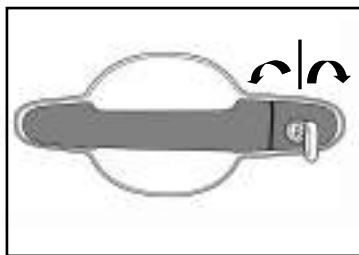

Use the key to lock and unlock the doors

Locking: turn the key towards the front side of the car

Unlocking: turn the key towards the rear side of the car

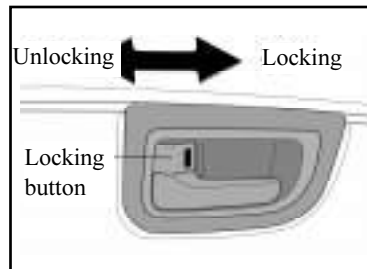

Use the locking button of the door lock to lock and unlock the doors

Locking: move the locking button of the door lock towards the front side of the car.

Unlocking: move the locking button

of the door lock towards the rear side of the car.

Lock the front doors from outside of the car

Move the locking button of the door lock towards the front side of the car; at the same time when pulling the external handle of the door, close the front door; the door could be locked.

Lock the rear doors from outside of the car

Move the locking button of the door lock towards the front side of the car; no need to pull up the external handle of the door; the door could be locked when closing the door.

Note: Don't leave the key in the car.

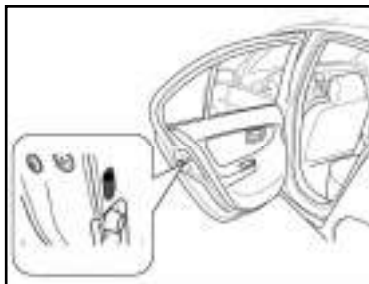

Child restraint system at the rear door

Move the lock lever to the lower position.

The rear door could be locked by using this function. The door could only be opened from outside. This device is usually used when there is a child in the car.

Warning

You must make sure that all the doors are closed and locked before driving the car, especially when there is a child in the car. Under the normal condition of using seat belt, locking the door may prevent the doors from opening suddenly to avoid the driver and the passengers being thrown out from the car when encountering a car accident.

—Central door lock

When the driver unlock or lock the front left door, all the other doors could be unlocked or locked simultaneously.

Parking-unlocking function (if equipped)

If your car is equipped with remote

lock, when the car is switched off and the key is pulled from the ignition switch, all the locking buttons of the door locks will be unlocked automatically.

—Remote lock (If equipped)

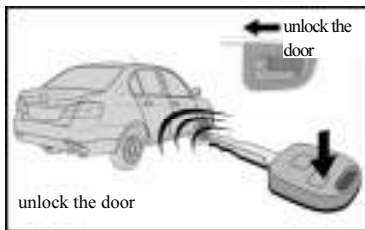
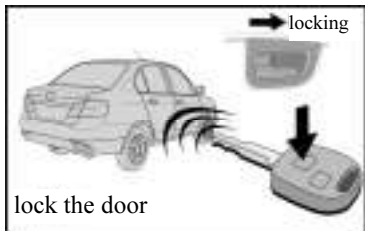

Lock and unlock the door
Press emitter switch to lock and unlock all the doors.

Locking: press “LOCK” switch, all the doors will be locked, at the same time, the turning lamps will flash once. Please check all the doors for locking before you leave the car.

If a door is not closed, or the key is inserted in the ignition switch, “LOCK” switch will not work.

Unlocking: press “UNLOCK” switch, all the doors will be unlocked, at the same time, the turning lamps will flash twice. After using unlocking function of

the remote switch, you should open one of the doors within 30 seconds; otherwise, all the doors will be locked again automatically, at the same time, the turning lamps will flash once.

When any of the following conditions occurs, the battery in the key may be dead, please replace the battery. (See “Replace the battery in the emitter”)

- The remote control does not work.
 - The effective range of the remote control becomes narrower.
 - The indicating lamp on the key is dim, or does not lamp.
- Wireless remote control emitter
Wireless remote control emitter is an electronic component; you shall abide by the following instructions to prevent it from damaging:
- Do not put the emitter on the

instrument panel whose temperature may become high.

- Do not dismantle it.
- Do not use other object to knock it, or throw it.
- Do not put the emitter in the water.

If the wire remote control emitter cannot operate the doors, or cannot work within the normal distance, you shall:

- Check whether it is near other wireless signal emitting area. The wireless signal emitted from radio station or air port may effect its normal operation.
- Check its battery. It may be dead.

Replace the emitter battery

Please use CR1616 lithium battery or its equivalent to replace the battery.

Replace the battery according to the

following steps:



1. Use the tool to open the key cover, take out the emitter from the key.

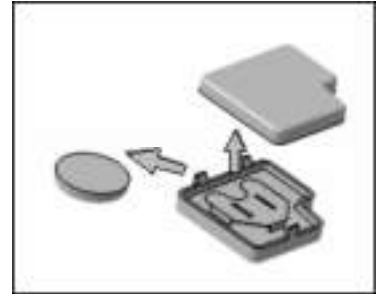

2. Use the tool to open the emitter cover, take out the battery, put the new battery in the emitter, with the anode (+) upwards.
3. Latch on the emitter cover. Put the emitter back to the key, and latch on the key cover.

Note

- Make sure that the anode and cathode of the emitter battery is in correct direction.

- Do not bend the electrode of the battery holder. Do not make the dust and oil stick to the emitter cover.
- Latch on the emitter cover.

Check the emitter for normal operation after replacing the battery.

— Power windows

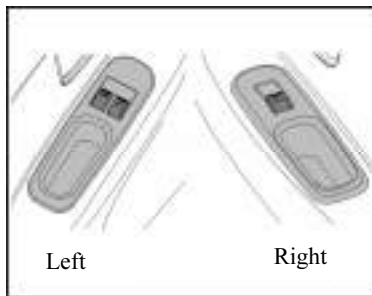

Front windows are power windows.

Two window switches in the interior trim panel of the door at the driver's side control front left/right window respectively. The window switch in the interior trim panel of the front right door controls the front right window.

The rear windows are manually operated. Turn the handle of the window machine counterclockwise to move down the window glass; turn the handle of the window machine clockwise to move up the window glass.

Operation of the power window at driver's side

The switch of power window at driver's side is located at the interior trim panel of the door at the driver's side, with the mark of "AUTO". The window at the driver's side has "automatically full-open" function, i.e. press the switch fully, the window glass will

move down to full-open position automatically. If you conduct inching-following operation, press the switch to central position, the window glass will stop moving down with the release of the switch. Move up the switch, the window glass will stop moving up with the release of the switch.

Operation of the power window at co-driver's side

The power window at co-driver's side is located at the interior trim panel of the door at the driver's side and at the interior trim panel of the front right door, without the mark of "AUTO". Release the switch after moving it up or pressing it down, the window glass will stop at the current position.

 **Warning**

In order to protect the passengers from being injured, you need to observe the following rules:

- Make sure that the head, hand and other parts of the body of all passengers will not be nipped by the window when closing power window.

- When the child is in the car, do not let him use power window switch if no one instructs him.

- Do not leave the child alone in the car, especially when the key is inserted in the ignition switch. He may be nipped by the window due to using power window switch. Neglected child will become the potential risk factor of causing accident.

Luggage compartment lid



If you want to open the luggage compartment lid from the outside, please insert the key and turn it clockwise.

You need to push the luggage compartment lid up to make it safe to avoid injuring the person due to falling down of the luggage. If you want to close the luggage compartment lid, please put down

the luggage compartment lid and press it down. After closing, attempt to lift it up to make sure that it is securely closed.

 **Warning**

You cannot drive the car until the luggage compartment is closed. This not only can prevent the luggage from throwing out, but also prevent the poisonous gas from entering into the car.



Unlocking handle

You may open the luggage compartment lid by moving up the unlocking handle at the outside of the driver's seat.

—Engine hood



Open the engine hood according to the following steps:

1. Pull the opening handle of engine hood, the engine hood will be popped-up slightly.

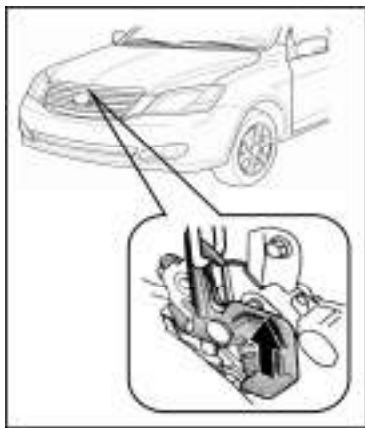
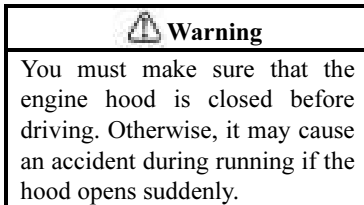

2. Stand in front of the car, move up the latch hook by hand(s) and lift up

the engine hood.



3. Insert the strut rod into the long hole in the engine hood to support the opened engine hood.

Before closing the engine hood, you shall check for tools or rag in the engine compartment. In order to avoid abnormal sound, you shall put the strut rod in the clamp, then, put down the engine hood and lock it correctly. If necessary, you may press the front edge gently to lock the engine hood.

 **Warning**

- After inserting the strut rod into the long hole, you shall make sure that it provides secure support to prevent the head or body from being injured due to falling down of the engine hood.
- In the state of engine hood being supported, if you press the engine hood hard, it will be deformed.

— Fuel tank cap



1. You can open the fuel tank cap by pulling up the opening handle. When fueling, you shall switch off the engine.

 **Warning**

- It is not allowed to smoke, produce spark or lamp fire up when fueling, for the fuel vapor is inflammable.
- If you open the fuel tank cap suddenly in the high temperature weather, the gasoline will spout under the action of pressure, causing injury to the people. Thus, do not remove the fuel tank cap too fast just when unlocking it.

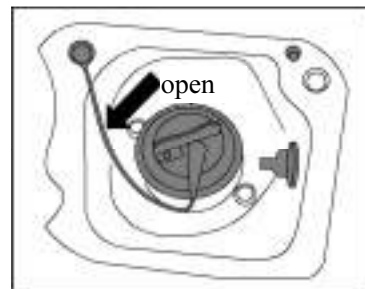

2. You shall turn the fuel tank cap counterclockwise slowly when unlocking it. You shall stop for a while before removing it. When lock the fuel tank cap, primarily, you shall make the claws under the fuel tank cap align to the breach of the oil tank port, then, turn it clockwise, and fasten it.

 **Warning**

- You must make sure that the fuel tank gap shall be fastened to prevent the fuel from leaking in the accident.
- You can only choose accessories made by Designated workshop when you want to replace the fuel tank cap. The negative pressure valve in the fuel tank cap may reduce vacuum degree in the fuel tank.

— Seats

During running, the backrest shall be upright. Every passenger shall hold himself in a respectful posture while sitting in his seat and fasten seat belt.

 **Warning**

- You cannot start the car if the passenger does not sit properly. It is not allowed to sit on the folded backrest or in the luggage compartment. The passenger will be injured when conduct emergency brake or car crash if he does not sit correctly or fasten the seat belt properly.

— Front seats

Notes for seat adjustment

Adjust the driver's seat to make the pedal, steering wheel and instrument panel within the operative range for the driver.

 **Warning**

- During adjustment, the seat may slip unexpectedly, thus, do

not adjust the seat during driving, for fear that the driver loses the control of the car.

- When adjusting the seat, please do not make the seat hit the passenger or luggage.

- After adjusting the seat, try to move the seat forward and backward to make sure that the seat is locked at the proper position.

- After adjusting the backrest, apply the pressure by the body to make sure that the backrest is locked at the proper position.

- The objects shall be put in the glove box. Do not put the objects under the seat. The objects may affect the locking mechanism of the seat or push the position-adjusting lever unexpectedly, causing the seat slipped suddenly, and the driver loses the control of the car.

- During seat adjustment, do not put your hands under the seat or approach the moving parts to avoid being injured.



Adjust front seats

1. Adjust seat position

Pull up the operating lever under the seat; move the seat to the proper position, then, release it.

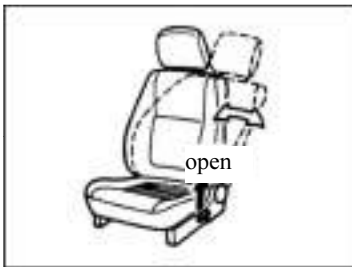

2. Adjust the angle of the backrest
Sit slightly forward and move up the adjusting handle, then, leaning backward to a proper angle, release it.



Warning

In order to reduce the danger that the body is slipped from the lap belt, do not tilt the backrest beyond your need. If the driver and the passenger sit upright and lean against the seat, the seat belt could provide them with maximum protection when encountering car crash. If you sit slantingly in the seat, the lap belt may slip to your crotch, and the constraint force will be directly on your abdomen. Thus, the risk of personal injury increases with increasing of the seat angle.

— Rear seats

Rear folding seats

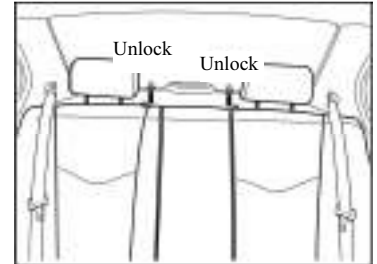

1. Pull up the locking handle

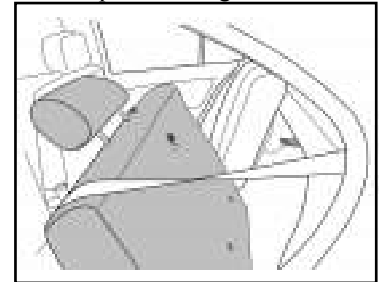

2. Fold the rear seats

Two backrests of the rear seats may fold separately, so as to take full advantage of the rear space.

Pull up the handle above the left/right seat, release the lock, the backrest will lean forward.

When you want to return it to the original position, pull up the backrest and push backward, it will be locked automatically, then, check it for securely locking.

Warning

- When return the backrest to the upright position, you shall confirm that the seat belt is not twisted or is hung on the backrest. Put it at the proper position for use.

- Pull the upper side of the backrest forward/backward to make sure that it is locked

securely. If you have ever removed the head rest, you have to install it to the original position.

- Do not adjust the seat during driving.

—Headrests

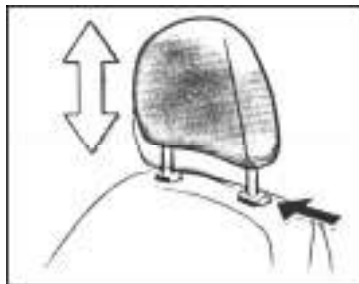

For safety purpose, the driver shall adjust the headrest before driving the car.

Raising: pull the headrest up.

Lowering: at the same time when pressing the locking button, press the headrest down.

The headrest will be the most effective when it is close to the head, thus, we suggest you do not use back cushion on the backrest.

Warning

- When adjusting the headrest, you shall ensure that the center of the headrest aligns to the upper of the ear.

- After adjusting the headrest, lock it.

—Seat belts

Note for seat belt

When the car is running, the driver and the passengers shall wear the seat belt. Otherwise, it may increase

the injury probability and degree in the car crash.

Child restraint system shall be used when he cannot wear the seat belt.

If the stature of the child is too big to use the child restraint system, he shall sit in the rear seats and fasten the seat belt. According to the accident statistics, the child sits in the rear seat with the seat belt fastening is safer than he sits in the front seats.

If the child has to sit in the front seat, he must wear the seat belt correctly. It is not allowed to stand or kneel on the front/rear seats. The child without the seat belt protection will be injured seriously during emergency brake or in the car crash. Do not let the child sit on your legs, this cannot provide enough restrict. Pregnant women are suggested that use seat belt, which shall be worn

above the crotch as low as possible. Do not put it on the abdomen.

 **Warning**

During driving, the passenger shall always sit in the seat and wear the seat belt correctly. Otherwise, he will be injured seriously during emergency brake or in the car crash.

You shall observe the following rules when using seat belt:

- One seat belt is only used for one person. Even though the child, never use one seat belt for two or more children.
- Avoid the seat tilting too much. When the backrest is at upright position, the seat belt could provide the maximum protection. (Refer to seat adjustment instructions)
- Do not damage the belt. Do

not catch the seat belt in the seat or in the door.

● Check seat belt regularly. Check whether the parts are broken, worn and loose. The worn parts shall be replaced. Do not take apart or modify the system.

● Keep the seat belt clean and dry. Please use neutral detergent to wash it, while do not use bleach, dye or detergent with corrosiveness, for they will damage the seat belt seriously. (See relative contents in Section V “Internal Cleaning of the Car”)

● If the car has gone through serious car crash for once, you need to replace seat belt system (including bolt). Even though the damage is not obvious, you shall also replace the whole system.



Three-point type

Adjust the seat to the proper position (front seats), sit upright and lean against the backrest, pull out the seat belt and buckle it.

When the spring bolt is locked in the buckle, you could hear the sound of “click”.

The seat belt may automatically adjust the length to fit for your stature and seat position.

When use emergency brake, or impact occurs, the retractor will

lock the seat belt. If you tilt forward too fast, it may also lock it. You may elongate the seat belt by slowly and steadily pulling, which will make you move about freely.

When the seat belt cannot pull out from the retractor, you may tighten it a little, and then release, the seat belt could be pulled out from the retractor smoothly.

Warning

- When inserting the spring bolt, you shall ensure that it is locked in the buckle, and the seat belt is not twisted.
- Do not insert the coin or clip into the buckle hole, for this will prevent the spring bolt from locking in it.
- If the seat belt does not work, please contact Designated workshop immediately. You shall not use the seat before its seat belt is

repaired, for it cannot provide protection for the adult and child.

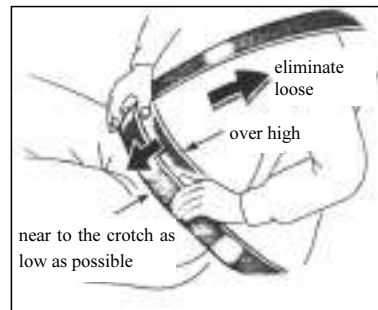

Adjust the seat belt at the lap and at the shoulder

The lap belt shall be near to the crotch as much as possible. Do not put it on the waist; then, pull up the shoulder belt to adjust to the position which is cleaved to the body through locking plate.

 **Warning**

- There will be unexpected result during car crash, thus it may cause the passenger seriously injured due to over high or over loose lap belt. Thus, the lap belt shall be near to the crotch as low as possible.
- For your safety, do not put the shoulder belt under the arms.



Press the unlocking button of the

buckle, the seat belt will retract. If the seat belt cannot retract smoothly, pull out of it, check for winding or twisting. Then, confirm that it could retract smoothly.

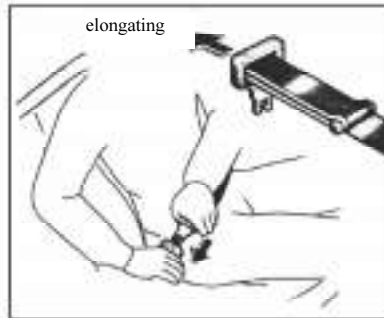

Two-point type

Sit upright and lean against the backrest correctly, insert the spring bolt into the buckle to fasten the seat belt.

When the spring bolt is inserted into the buckle, you will hear the sound

“click”.

If the seat belt is not long enough, hold the spring bolt to make it at right angles to the seat belt, and pull the spring bolt.

 **Warning**

- When inserting the spring bolt, you shall ensure that it is locked in the buckle, and the seat belt is not twisted.
- Do not insert the coin or clip into the buckle hole, for this will prevent the spring bolt from locking in it.
- If the seat belt does not work, please contact After-sales Designated workshop immediately. You shall not use the seat before its seat belt is repaired, for it cannot provide protection for the adult and child.

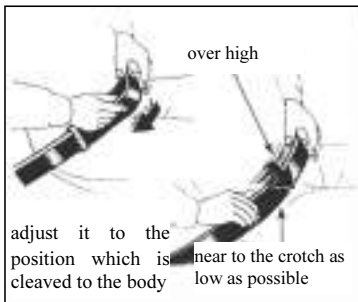

Eliminate the spare length of the seat belt and adjust the position. Pull the free end of the seat belt, then, tighten the clamp to strain the loose part of the seat belt. The lap belt shall be near to the crotch as much as possible. Do not put it on the waist; then, adjust the seat belt to a comfortable position.

 Warning
<ul style="list-style-type: none"> ● There will be unexpected result during car crash, thus it may cause the passenger seriously injured due to over high or over loose lap belt. Thus, the lap belt shall be near to the crotch as low as possible.

If you want to release the seat belt, please press the unlocking button of the buckle.

— Airbag (driver side) (if equipped)



Airbag is designed to provide further protection besides the protection of the seat belt. For seriously frontal impact, the inflated airbag works together with seat belt to prevent or reduce injury, and to reduce the possibility that the driver's head or chest directly hits the steering wheel or instrument

panel.
You must fasten the seat belt.

 **Warning**

When the airbag is operating, the driver will be seriously injured if he approaches the steering wheel or instrument panel too closely. It is strongly recommended that:

- As well as keeping the control of the car, the driver shall sit back as much as possible and keep away from the steering wheel.
- All the passengers shall fasten the seat belt.



When the ignition key turns to “ON”, this indicating lamp will lamp, six seconds later, it will extinguish. That means the airbag system works properly. Warning lamp system of airbag monitors ECU assembly of airbag, inflator, warning lamp, connecting line and power supply (See relative contents in 1-5 “Message and Caution for Maintenance”).

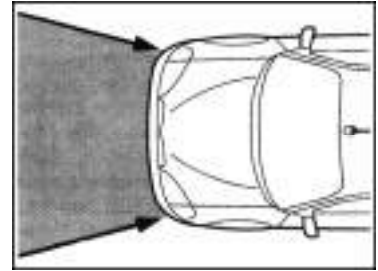

Airbag is designed to respond to the serious frontal impact (the shadow region along the arrows in the figure).

If the impact degree exceeds the designed domain value, the airbag will work. The domain value equals to the speed of 30km / h hits to a fixed and non-deforming obstacle.

If the impact degree is lower than the speed mentioned above, the airbag may not work.

If the car hits a movable and deformable object, such as parking

car or marking pole, or rear-end collisions (for example, the front of the car gets into the bottom of the truck), this domain value will be increased correspondingly.

For all the passengers' safety, they shall always fasten the seat belt.

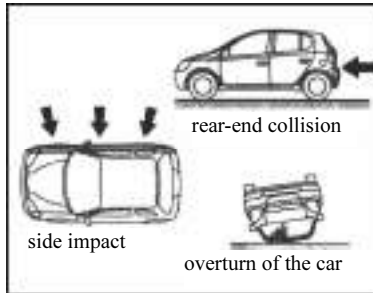

The airbag will not pop up if the car encounters side impact, rear-end collision, overturn or frontal impact with a low speed.

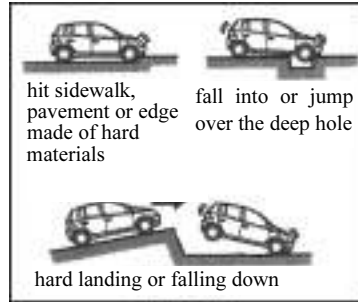

If there is a serious collision occurs at the bottom of your car, the airbag may be pop up (There are some examples in the figure).



Airbag system mainly includes the following components and parts, whose positions are shown in the above figure.

1. Warning lamp for safety
2. Airbag components for drive (airbag and expanding agent)
3. ECU assembly of airbag

When serious frontal impact occurs, airbag system will trigger the inflator. The chemical reaction in

the inflator makes the airbag filled up with non-harmful gas to restrain the body movement of the driver and front passenger.

When the airbag expands, it will make a considerable noise, with non-harmful gas and let out some smoke and produce some remnants, but that does not mean somewhere is on fire. Although the gas is non-harmful, it may cause slight discomfort to the people with delicate skin. In order to avoid such discomfort, you need to wash the remnants as soon as possible.

The airbag works within a fraction of a second, thus, the inflation force is very enormous. The system is to reduce the serious injury, but it may still cause slight burning, corrosion and bruise.

Some airbag components (wheel

hub of the steering wheel, instrument panel) may be hot for several minutes, but the airbag itself will not be hot. The airbag will be scrapped for inflation once.

When the car is deformed due to car collision, the strong impact of the airbag inflation may break the windscreen.

Warning

Airbag system is designed as a supplementary protection besides the driver's seat belt. If the driver does not wear the seat belt, he will be injured seriously by the expansion of the airbag. Before the emergency brake of the car crash, the driver without restraint will approach the operating airbag in the collision. The driver and all the passengers

must wear the seat belt to gain the maximum protection. Wearing the seat belt may reduce the possibility of being injured or thrown out of the car. See relative contents in 1-3 "Seat Belt".



▶ Do not put the objects or pet on the instrument panel, decorative cover of the steering wheel or front side. They may restrain the airbag

expansion, or when the airbag is working, it will pop up backward to cause people injury. Similarly, do not put objects on your arms or knees.

► Do not modify or dismantle any wire harness. Do not change, dismantle, hit or open any of the following parts, such as the decorative cover of the steering wheel, steering wheel or the shell of the steering column. The behavior mentioned above may cause airbag inflation or failure, and this will lead to serious injury.



The airbag system has an indicating lamp to tell the driver the problem occurred in the operation. If any of the following conditions occurs, that shows the airbag is with fault, please contact designated workshop immediately to repair the car.

- When the ignition key turn to “ON”, the indicating lamp does not light, or has been lighting on, not extinguish.
- During driving, the indicating lamp lights or flashes.

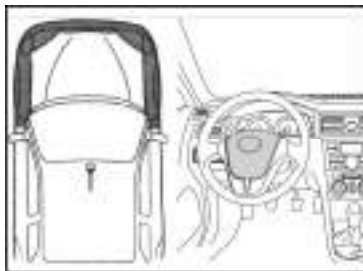

If the following conditions occur,

please contact designated workshop as soon as possible.

- The airbag has been expanded.
- The accident involves in the front end of the car (the shadow area in the figure), but not cause airbag expansion.
- The decorative cover of the steering wheel is scratched, cracked or damaged.

Note

Do not cut off the power cord before contacting Designated workshop.

— Outside rear-view mirror



Adjust the rear-view mirror to make sure that you could see the side rear part of the car.

Pay attention to the size and distance saw from the rear-view mirror (passenger side). It is a convex mirror; any object saw from it is smaller and further than of that saw from flat mirror.

Warning

Do not adjust the angle of the rear-view mirror during driving. Otherwise, it may cause driving error, accident and personal injury.

Operation of rear-view mirror (power type) (if equipped)
Use the switch to adjust the rear-view mirror

1. Main switch—— choose the rear-view mirror which needs to be adjusted. Move the switch to L (left) or R (right).

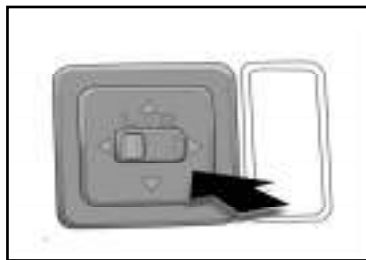

Notice

In case of ice appeared on the rearview mirror surface, do not handle the switch or clean the mirror surface directly, you should spray deice agent over the mirror surface first.

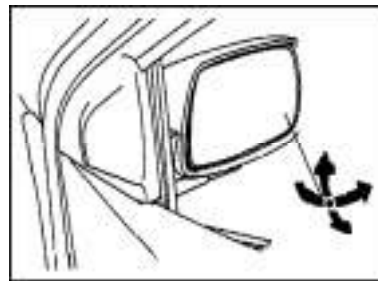

Handle the rearview mirror (manual)
(if fitted)

The angle of the rearview mirror
can be adjusted manually.

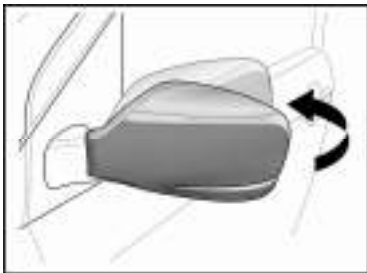

Folding rearview mirror

The folding rearview mirror can be
folded when parking space is
limited.

Folding rearview mirror requires
pushing the rearview mirror
backward till the sound of “click”
can be heard.

Warning

Do not drive the car with the
rearview mirror folded. Before
start the car, you must unfold the
rearview mirror and adjust the
rearview mirrors both at the
driver’s side and passenger’s
side.

Notice

Stop pushing the rearview mirror
backward when you heard the
sound of “click”. Otherwise it
will damage the rearview mirror
or car.

—Inside anti-dazzle rear-view mirror

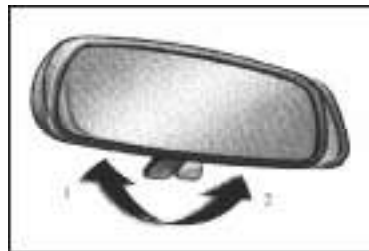

Adjust the rearview mirror inside
the car to enable you to see the back
part of the car from the mirror.

For night driving, you can handle
the adjust bar at the lower edge of
the rearview mirror to reduce the
lamp glare from the car behind you.
Day driving-set the adjust bar into
right position 1

At the position, the object reflected
from the rearview mirror is more
visible.

Night driving- set the adjust bar into position 2

Remember: When you reduced the glare light from the car behind, you also reduced the visibility.



Warning

Do not adjust the rearview mirror inside the car during driving; otherwise it will result in error operation by the driver, and will cause accident and injury.

—Vanity mirror

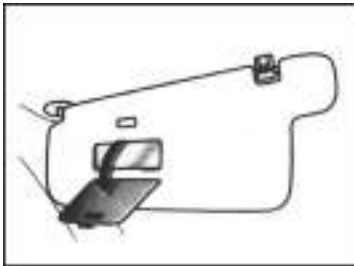

Be located at the back of sun visor for driver and front passenger.

It's strictly prohibited for the driver to use this during the driving, in order to guarantee the driving safety.

—Interior lamp

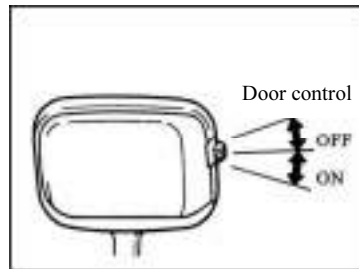

Toggle this switch to turn on the interior lamp.

The interior lamp switch has the following positions:

“ON” – The interior lamp is always on.

“OFF” – The interior lamp is turned off.

“DOOR” – The interior lamp will be turned on when whichever the door is opened.

When the door is closed, the interior lamp will go off.

—Headlamps and turn signals

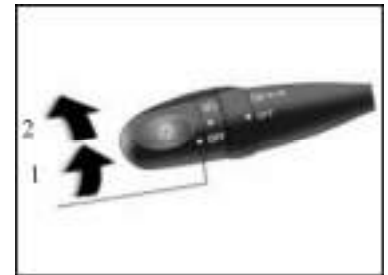

Headlamp

Turn the lamp switch handle to turn on the following lamps.

Position 1 – Front position lamp, rear position lamp, license plate lamp, and instrument panel lamp.

Position 2 – Low beam , besides the above-mentioned lamps.

Notice

To prevent the excessive discharge of the battery, do not turn on the lamps for a long period while the engine is not running.

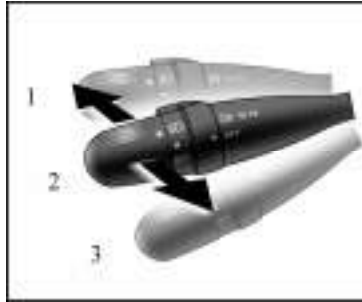

High beam – Low beam – To shift to high beam, turn on the headlamp and push the handle to far position of the driver (position 1). Pull the handle towards the driver to shift to low beam (position 2).

In such case, the high beam indicator lamp on the instrument cluster will inform the driver that the high beam is turned on.

High beam flasher (position3) - Push backward the handle to turn on the high beam and release the

handle to turn off the high beam.

When the handle is at “OFF” position, the high beam flasher still can function.

Turn signal lamp

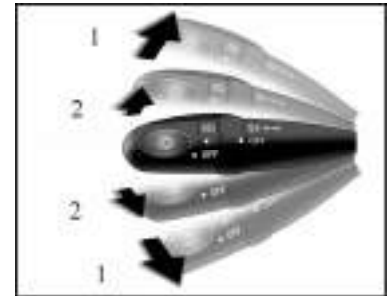

To issue the turn signal, push upward or downward the turn signal lamp handle to position 1.

The key must be turned to “ON” position.

The handle can automatically return after the turn. In addition, it can return the handle with hand after the

change of driving lane. To issue the lane change signal, move upward or downward the handle to pressure point (position 2) and maintain at this position. If the turn signal indicator lamp (green) on the instrument cluster flashes faster than normal speed, it indicates that the front or rear turn signal lamp is burnt out.

—Hazard warning signal

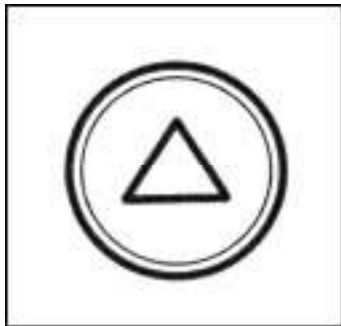

To turn on the hazard warning lamp, press this switch.

In such case, all turn signal lamps will flash at the same time. Press this switch again to turn off the hazard warning lamp. If it's necessary to park the car in the area with heavy traffic, turn on the hazard warning lamp to remind other drivers.

When the hazard warning lamp is functioning, the turn signal lamp switch can't function.

Notice

To prevent the excessive discharge of the battery, immediately turn off the hazard warning lamp once the hazard is resolved if the engine is not running.

—Rear fog lamp



The rear fog lamp can be turned on only when the headlamp is turned on. The rear fog lamp can be turned off independently.

Turn on the headlamp and shift the fog lamp switch to the position with rear fog lamp marking. In such case, the rear fog lamp indicator lamp on the instrument cluster will remind you that the rear fog lamp is turned on.

The rear fog lamp will be turned off

along with the turn-off of the headlamp. To turn off the rear fog lamp only, shift the rear fog lamp switch to OFF position.

—Windshield wiper and washer



As required, move the handle to the ideal position to start the windshield wiper. In such case, the key must be turned to “ON” position.

Handle position	Speed setting
Speed 1	Intermittent
Speed 2	Slow
Speed 3	Fast

Wiping once, pull upward the handle and release. Pull the handle towards the driver to spray the washing fluid. Please refer to the information in 7-3 “Adding washing fluid”. In cold weathers, before using the washer, use the defroster to warm the windshield, which can prevent the washing fluid from being frozen on the windshield to obstruct the viewing.

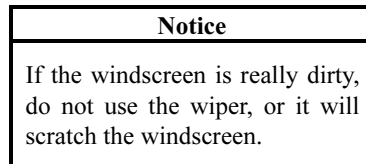

—Rear defroster

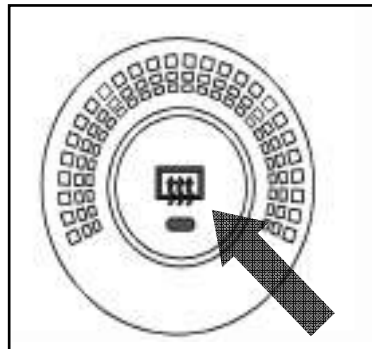

The rear defroster switch is located on the A/C control panel. Press this switch to defrost or defog

the rear windscreen.

In such case, the key must be turned to “ON” position. The tiny resistance wires on the inside of rear windscreen can rapidly clean the surface. When the defroster is functioning, the indicator lamp on the button will go on. Press the switch again to turn off the defroster.

After the rear windscreen is cleaned, turn off the defroster. The long-period functioning of the defroster will lead to the excessive discharge of the battery, especially during the startup from parking.

If there is frozen ice on the surface of rear windscreen, clean the ice with deicing sprayer before using the defroster.

Notice

- ◆ To prevent the excessive discharge of the battery, use the defroster while the engine is running.
- ◆ When cleaning the internal surface of the rear windscreen, notice not to scratch or damage the resistance wires.

— Fuel gauge

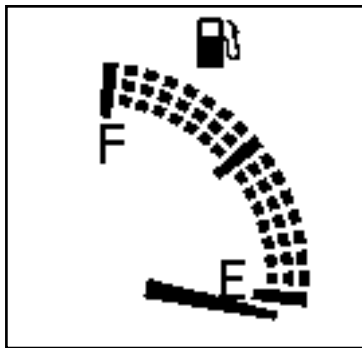

When the ignition switch is at “ON” position, the fuel gauge functions indicates the approximate amount of residual fuel in the fuel tank.

Almost full: Pointer at “F”.

Almost empty: Pointer at “E”.

It’s advisable that the fuel amount in the fuel tank shall not be less than 1/4 of the normal capacity.

If the pointer of the fuel gauge closes to “E”, add fuel to the fuel tank immediately.

When driving on slopes or curves, due to the vibration of fuel in the fuel tank, it may lead to the swing of fuel gauge pointer.

—Engine coolant temperature gauge

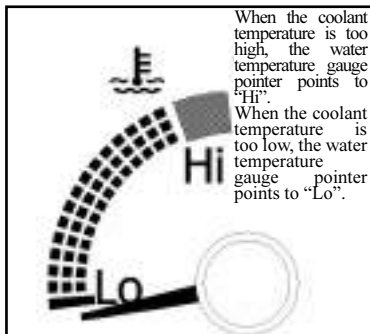

When the ignition switch is at “ON” position, the water temperature gauge indicates the approximate temperature of engine coolant.

If the engine coolant is cold, the pointer of water temperature gauge stays still.

If the pointer of water temperature

gauge stays still after the engine is fully warmed up, please contact with designated workshop for necessary checking and repair.

If the temperature of engine coolant is too high and the pointer of water temperature gauge closes to “Hi”, it indicates that the engine is overheated. In such case, stop the car to cool down the engine.

While working under relatively harsh conditions, the car will be overheated, such as:

- Travel on relatively longer mountain road in hot weather.
- Deceleration or stop after traveling at high speed.
- frequent stop and startup or idle running for a long period, with activated A/C.
- When being towed.

Notice

◆ Do not remove the thermostat from the engine cooling system. The thermostat is functioned to maintain the temperature of the flowing coolant within the normal working temperature range of the engine.

◆ Do not continue traveling when the engine is overheated. Please refer to the information in Chapter IV “In event of engine overheating”.

—Tachometer

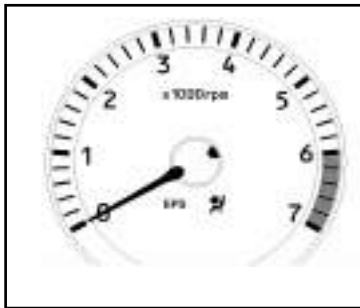

The tachometer indicates the engine speed in unit of 1,000 revolutions per minute. The tachometer can assist the driver to choose the correct gearshift point, in order to prevent engine overload or excessive engine speed. The excessive engine speed will result in the excessive engine wearing and increased fuel consumption. Please bear in mind that, under most

conditions, the lower the engine speed is, the better the fuel consumption is.

—Odometer and trip meter

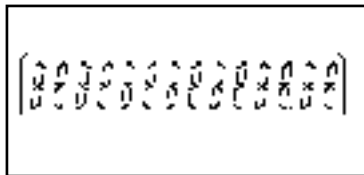







This gauge indicates the total mileage and the trip mileage.

1. Odometer – Indicate the total mileage of the car.
2. Trip odometer – Indicate the mileage of last trip after being reset. The trip odometer can be used to calculate the fuel consumption and measure the traveling mileage.

3. Trip odometer reset button – Reset the trip odometer to zero.
4. Press the trip odometer reset button to switch between the odometer and trip odometer.
5. To reset the trip odometer to zero, firstly switch to the reading of odometer and press and hold the button, till the reading of odometer is reset to zero.

—Warning lamps and indicator lamps

If ON	Action
(a) 	If the parking brake is not engaged, please immediately contact the <u>Designated workshop</u> for help.

(b) 	Stop for checking.
(c) 	Stop for checking.
(d) 	Ask <u>Designated workshop</u> for help that the car needs checking and repair.
(e)  (If equipped)	Ask <u>Designated workshop</u> for help.
(f)  (If equipped)	Ask <u>Designated workshop</u> for help immediately.
(g) 	Securely close all doors.
(h) EPS	Ask

(If equipped)	<u>Designated workshop</u> for help immediately.
(i) EBD (If equipped)	Ask <u>Designated workshop</u> for help immediately.

(a) Brake system warning lamp.
After the ignition switch is turned on, this warning lamp will go on in event of following conditions.

- The parking brake is still engaged.

- Insufficient brake fluid.
When the ignition switch is at “ON” position and the parking brake is engaged, but the warning lamp is not on, make sure to deliver the car to Designated workshop for checking.

 **Warning**

When the engine is running, if this warning lamp is still on upon the disengagement of the brake lever, immediately stop the car in safe location and contact the Designated workshop.

In such case, the brake system may not function normally and the braking distance of the car will be very long. In such case, depress the brake pedal with force.

(b) Charging system warning lamp
In event of fault in vehicle charging system, this lamp will issue warning signal.

If this lamp goes on during the traveling, it indicates the fault in charging system. In such case, turn off the accessories such as A/C, heater, and radio and drive the car

directly to designated workshop for checking and repair.

Notice
If the drive belt of the engine is broken or loose, please do not continue driving.

(c) Low engine oil pressure warning lamp

This lamp will issue the warning if the engine oil pressure is really low. If this lamp is always on or flashes continuously during the traveling, stop the car in safety location, immediately turn off the engine, and ask the designated workshop for assistance.

This lamp may occasionally go on during the engine idling and may go on temporarily after the sudden braking. However, if this lamp goes off after the slight acceleration of

the engine, it indicates that the car is functioning normally.

This lamp will also go on when the engine oil is extremely low. However, this lamp is not designed for the indication of engine oil amount and the level of engine oil must be measured with the dipstick.

Notice
When the warning lamp goes on, please do not continue traveling, even for a short distance, or it will damage the engine.

(d) Engine fault indicator lamp

In event of fault in engine electronic control system or OBD, this lamp will issue the warning.

If this lamp goes on during the driving, please ask the designated workshop for checking and repair as soon as possible.

(e) ABS warning lamp (if equipped)
When the ignition switch turns to “ON” position, this warning lamp will go on. If the anti-lock brake system functions normally, this warning lamp will automatically go off after several seconds. Afterwards, in event of system fault, this warning lamp will go on.

When the “ABS” warning lamp goes on (and the brake system warning lamp goes off), the anti-lock brake system can’t function, but the brake system can still function.

In such case, as the anti-lock brake system can’t function, it will lead to lock of wheels in event of sudden brake or in event of braking on slippery roads.

In event of presence of following conditions, it indicates the fault of certain component under monitoring of warning lamp system.

In such case, please contact the designated workshop for repair as soon as possible.

- The ABS warning lamp can't go on or is always on while the ignition switch is turned to "ON" position.
- The ABS warning lamp is always on during the traveling.

If this warning lamp goes on and then goes off automatically and will not go on again during the traveling, this phenomenon is normal.

(f) Airbag warning lamp (if equipped)

When the ignition switch is turned to "ON" position, this warning lamp goes on and then goes off after approximate 6s. It indicates that the airbag system is functioning normally.

The warning lamp system monitors the airbag ECU assembly, gas generator, warning lamp, connecting harness, and power

supply.

In event of presence of following conditions, it indicates the fault of certain component under monitoring of warning lamp system. In such case, please contact the designated workshop for repair as soon as possible.

- this warning lamp can't go on or is always on while the ignition switch is turned to "ON" position.
- This warning lamp goes on or flashes during the traveling.

(g) Door ajar warning lamp

This warning lamp goes off after all doors are securely closed.

(h) EPS warning lamp (if equipped)

When the ignition switch is turned to "ON" position, this warning lamp goes on and then goes off after the engine is started for several seconds. It indicates that the EPS system is functioning normally.

In event of presence of following

conditions, it indicates the fault of electronic power steering system (EPS). In such case, please contact the designated workshop for repair as soon as possible.

- When the ignition switch turns to "ON" position, this warning lamp can't go on.
- This warning lamp is always on after the engine is started.
- This warning lamp goes on during the traveling.

(i) EBD warning lamp (if equipped)

When the ignition switch turns to "ON" position, this warning lamp will go on. If the EBD functions normally, this warning lamp will automatically go off after several seconds. Afterwards, in event of system fault, this warning lamp will go on.

In event of presence of following conditions, it indicates the fault of EBD system. In such case, please

contact the designated workshop for repair as soon as possible.

- The EBD warning lamp can't go on or is always on while the ignition switch is turned to "ON" position.

- The EBD warning lamp is always on during the traveling.

Check "warning lamps and indicator lamps"

- 1.Engage the parking brake.

- 2.Open one door. The door ajar warning lamp shall go on.

- 3.Close all doors. The door ajar warning lamp shall go off.

- 4.Rotate the ignition switch to "ON" position, but do not start the engine. In such case, all warning lamps shall go on and after several seconds the airbag warning lamp, "ABS" warning lamp, and "EDB" warning lamp shall go off.

If any warning lamp or indicator lamp fails to function as described above, the bulb may be burnt out or

there is any fault in the system. Please ask the designated workshop for repair as soon as possible.

—Ignition switch with steering wheel lock

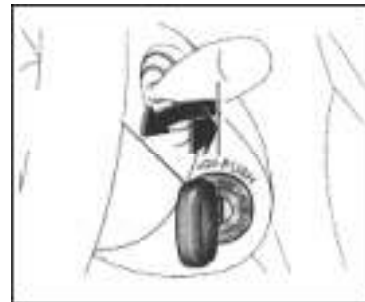

"START": Start the engine. Upon release, the key will automatically return to "ON" position.

Please refer to the related information in Chapter III "Start-up and driving".

"ON": The engine is running and all accessories are powered.

This position is the position of the

key during the normal traveling.

“ACC”: Some accessories (such as radio) can function, but the engine is not running.

“LOCK”: The engine is not running and the steering wheel is locked. Only in this position can the key be pulled out.

Only by pushing inward and rotating the key can rotate the key from “ACC” position to “LOCK” position.

During the engine start, sometimes the key seems like being blocked at the “LOCK” position and can't be rotated. To rotate the key, firstly determine whether the key is fully inserted and then try to rotate the key while lightly rotating the steering wheel.



Warning

Do not pull out the key during the traveling, or the steering wheel will be locked to cause direction out of control.

Notice

When the engine is not running, do not place the key at “ON” position, which will lead to the discharge of battery and damage of ignition switch.

— Manual shift system

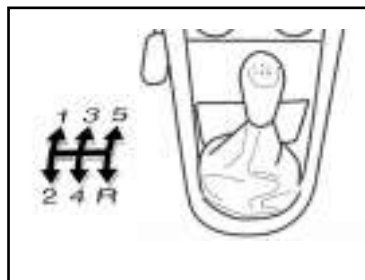

The gears of the transmission are shown in the figure above.

Conduct the gearshift while fully depressing the clutch pedal and then slowly release the clutch pedal. During the traveling, do not rest the foot on the clutch pedal, or it will result in the fault of the clutch. To park the car on the upslope, use the parking brake instead of the clutch to control the car.

Good driving habits

- If it's difficult to shift to reverse gear, shift the transmission to neutral gear, immediately release the clutch pedal, and then try again.

Notice

Before shifting to the reverse gear, make sure that the car is completely stopped.

—Parking brake system

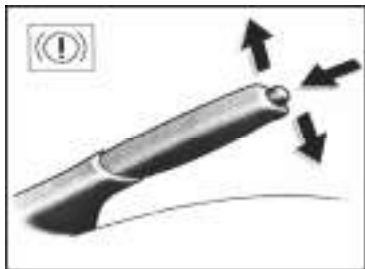

To park the car, tightly engage the parking brake lever to prevent the accidental movement of the car.

Engage the parking brake: Pull upward the parking brake lever. To achieve better braking effects, firstly depress the brake pedal and hold and then engage the parking brake.

Release the parking brake: Slightly pull upward the parking brake lever, press with thumb the button at the

end of the lever, and then lower the parking brake lever to the end. To remind you that the parking brake is engaged, the brake system warning lamp on the instrument panel is always on, until the parking brake is released.



Warning

Before start up, make sure that the parking brake is fully released and the brake system warning lamp is off.

—Use of audio system

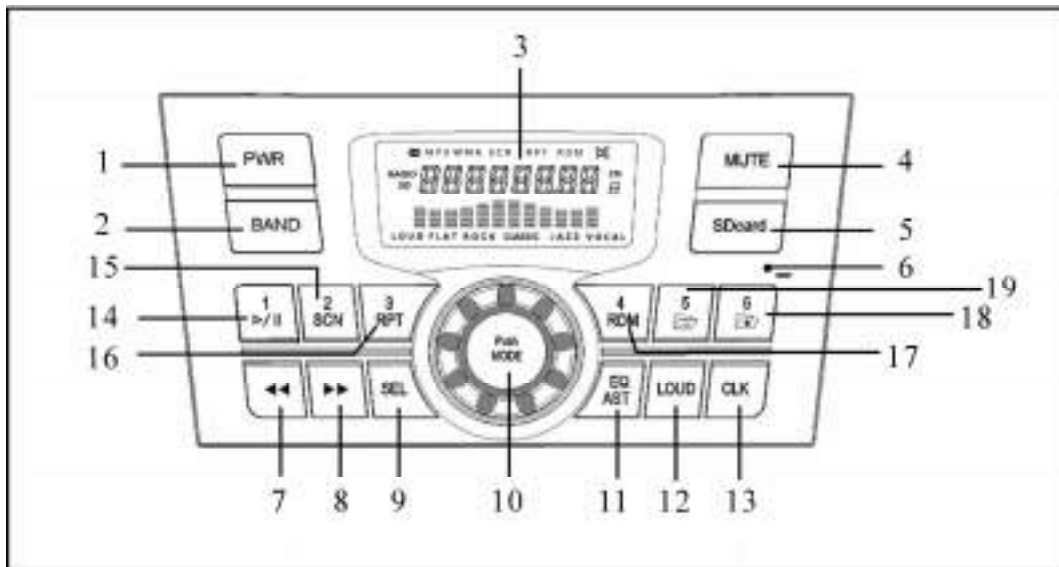

1. Power switch

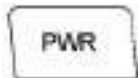

- Press this button to turn on/off the car audio system.

2. Band selection button



- Under radio mode, press this button to circulate the selection in turn:

FM1 (frequency modulation 1) ∇
 FM2 (frequency modulation 2)
 ↑ ∇ FM3 (frequency modulation 3)
 AM2 (amplitude modulation 2) !
 AM1 (amplitude modulation 1) 8

3. Display screen

- Display the information such as frequency, function, and operation status.

4. Mute button



- Under the radio or playback mode, press this button to mute the playing.
- At the press of this button, the display screen displays the “MUTE” and the playing is muted. Press this button again or rotate the encoder clockwise to cancel the mute and resume normal playing.

5. SD card socket

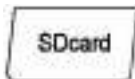

Insert the SD card

- Open the SD card cover, face the metallic face of SD card downward and the notch rightward, and insert into the SD card socket. Do not insert other foreign matter into the socket, in order to prevent damaging the machine.
- Under the power-on condition,

when the SD card containing the MP3 media is inserted, the audio system will automatically shift to SD card playback mode and the display screen will display the “SD”, track number, and playing time.

Disconnect the SD card

- Disconnect the SD card. If it is under the SD card playback mode currently, the audio system will return to radio mode.

SD card playback

- When the audio system is powered on and the current mode is other than SD card playback mode, press the “MODE” button to select the SD card playback mode.
- If it is the first time to enter into the SD card playback mode after the power-on, the audio system will play from the first track. If it is not the first time, the audio system will play from the track at

which it exits the SD card playback mode.

➤ When using the SD card playback mode, it's recommended to place the MP3 media into the root folder or one same folder of the SD card.

6.Reset hole (RESET)

➤ In event of abnormal functioning of the audio system (such as out-of-control of the buttons or abnormal reading of SD card), please press lightly the reset hole with something similar to the paper clip and re-use the machine after reset.

7.8.Automatic tuning buttons



Manual scan

➤ Under the radio mode, press the ◀◀ button to scan the radio stations upward and press the ▶▶ button to scan the radio station

downward. The frequency increases/decreases by one step at each press of the buttons.

AM: 9KHz

FM: 0.05MHz

Automatic scan

➤ Under the radio mode, press and hold the ◀◀ button to automatically scan the radio stations upward and press and hold the ▶▶ button to automatically scan the radio station downward.

Track selection

➤ Press these buttons to select any desired track forward or backward to play.

➤ Under the SD card playback mode, press the ◀◀ or ▶▶ button to select the track upward or downward. At the press of the ◀◀ button, the system will return to the beginning to play if the playing time of current track exceeds 2s and otherwise it will move to previous

track to play. At the press of the ▶▶ button, the system will move to next track to play.

➤ The track selection operation will cancel the functions of repeat playback, random playback, and scan playback.

Fast forward/rewind

➤ Press and hold these buttons to fast forward or rewind the playback.

➤ Press and hold the ◀◀ or ▶▶ button for more than 2s to enter into fast forward/rewind mode. Upon the release of the ◀◀ or ▶▶ button, the system will exit the fast forward/rewind mode and start normal playing from the time at which the button is released.

➤ The fast forward/rewind operation will cancel the functions of repeat playback, random playback, and scan playback.

9.Effects control selection button



➤ Press this button to access the Bass (BAS), Treble (TRE), Balance (BAL), and Fading (FAD) in turn. After selecting one mode, rotating the encoder to setup the sound effects. (Bass: -7—+7; Treble: -7—+7; Balance: L9—R9; Fading: F9—R9)

BAS mode: Rotate clockwise to maximum BAS boost and rotate counter-clockwise to maximum BAS attenuation.

TRE mode: Rotate clockwise to maximum TRE boost and rotate counter-clockwise to maximum TRE attenuation.

BAL mode: Rotate clockwise to most right end of BAL and rotate counter-clockwise to most left end of BAL.

FAD mode: Rotate clockwise to most rearward end of FAD and

rotate counter-clockwise to most forward end of FAD.

➤ Note: The treble and bass are adjustable only under the DSP OFF status.

10. Volume adjustment and mode



switch button

Volume adjustment

➤ Rotate this button to adjust the volume.

Rotate clockwise to increase the volume. The display screen displays “VOL 40” when the maximum volume is reached.

Rotate counter-clockwise to lower the volume. The display screen displays “VOL 0” when the minimum volume is reached.

Mode switch

➤ Press this button to switch between the RADIO mode and SD

card playback mode.

11. Automatic scan/save and equalizer selection button



Automatic scan/save the radio stations

➤ Under the radio mode, press and hold this button for 2s or above to activate the automatic scan/save function and save 6 strong radio stations within the entire band into 1~6 preset buttons in turn. The system can save 12 radio stations for AM and 18 radio stations for FM.

Equalizer selection

➤ Under the radio or SD card playback mode, press this button to in turn select the FLAT – ROCK – CLASSIC – JAZZ – VOCAL – DSP OFF mode. Depending on own favor, the user may select any mode for appreciation of music. Under

each above-mentioned mode, if there is no operation of this button within 5s, the system automatically exits this mode.

12. Loud playback



➤ Press this button to enter into loud playback mode and press again to cancel loud playback mode.

13. Time display button



➤ Press this button to display the time. When pressing and holding this button for 2s, the hour digit will flash. In such case, rotate the encoder to adjust the hour. When pressing the CLK button again, the minute digit will flash. In such case, rotate the encoder to adjust the minute. At finish of adjustment, wait for 5s to complete the time setup.

14. Preset button 1/ Pause/play



button

➤ Select radio station

Select the band and then press this button to listen the radio station saved in this button. In such case, the display screen will display the band, frequency and the present number.

➤ Save radio station

Select the band (such as FM1) and then tune to the desired radio frequency by pressing the automatic or manual scan button. Press and hold this button (for more than 2s). When the display screen displays the number “1” (present button number), the radio station is saved in this button. The screen will display corresponding number for

other preset buttons. In addition, when new radio station is saved, the old radio station saved in this button is superseded.

➤ Pause/play

Under SD card playback mode, press this button to pause the playing track. In such case, the screen will display “PAUSE”. Press again to resume the playing of current track.

15. Preset button 2/ Scan play button



➤ Select/save radio station

Refer to the procedure of radio station selection/save for preset button 1.

➤ Browse play

Under the SD card playback mode, press this button to scan play all tracks, with 10s for each track. In such case, the screen will display “SCN”. Press this button again to

cancel the scan play function.

16.Preset button 3/Repeat play



button

➤ Select/save radio station
Refer to the procedure of radio station selection/save for preset button 1.

➤ Repeat play

Under the SD card playback mode, press this button to repeat play the current track. In such case, the screen will display “RPT”. Press this button again to cancel the repeat play function.

17.Preset button 4/Random play

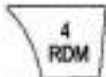

button

➤ Select/save radio station
Refer to the procedure of radio station selection/save for preset button 1.

➤ Random play

Under the SD card playback mode, press this button to randomly play the tracks in the SD card. In such case, the screen will display “RDM”. Pres/s this button again to cancel the random play function.

18.Preset button 5/Folder -



button

➤ Select/save radio station
Refer to the procedure of radio station selection/save for preset button 1.

➤ Under the SD card playback mode, press this button to select the folder upward, with corresponding display in the screen.

19. Preset button 6/Folder +



button

➤ Select/save radio station
Refer to the procedure of radio station selection/save for preset

button 1.

➤ Under the SD card playback mode, press this button to select the folder downward, with corresponding display in the screen.

Important:

➤ Due to the uneven compression quality of MP3 media in present market, it may result in the reading error of the system. Upon the detection that the playing of MP3 media is staggered and is always under reading status, please pull out the SD card and re-insert. Then, the SD decoder module can reset once automatically and resume normal playing.

Notices:

➤ Make sure that the SD card contains the MP3 media. If not, the system can't read out the SD card.

➤ Check whether the SD card is inversely inserted and whether the contact is good. Otherwise, the system can't read out the MP3

media.

➤ During the playing of SD card, please do not pull out the SD card directly, or it may damage the SD card.

➤ When the SD card playback mode is not selected, please cover the SD card socket properly. In event of accumulation of heavy dust in the SD card socket, it will result in the poor contact between SD card and the system and impair your appreciation of the MP3 media.

—A/C control panel

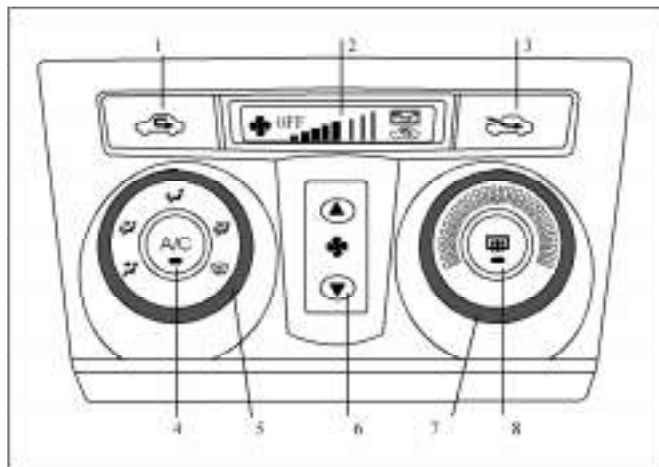

- 1. Internal recirculation button
- 2. Fan speed and internal recirculation display screen
- 3. External recirculation button
- 4. A/C switch button

- 5. Vent control knob
- 6. Fan speed up/down control button
- 7. Temperature selection knob
- 8. Rear defroster switch button

Fan speed up/down control button

Press up/down button to adjust the fan speed. Press \triangle button to increase the fan speed and press ∇ button to reduce the fan speed.

Temperature selection knob

Rotate the knob to adjust the temperature. Rotate rightward to “WARM” and rotate leftward to “COLD”.

Vent control knob

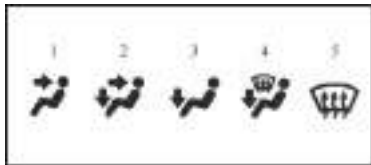

Rotate the knob to select the air flow.

1. Instrument panel vent: The air flow comes mainly from instrument

panel vents.

2. Two-way vent: The air flow comes from floor vents and instrument panel vents at the same time.

3. Floor vent: The air flow mainly comes from the floor vents.

4. Floor/windscreen vents: The air flow mainly comes from the floor vents and windscreen vents. When using this position, shift the air intake selection switch to “fresh air (external air)”.

5. Windscreen vents: The air flow mainly comes from the windscreen vents, which is used to defrost and demist the windscreen. When using this position, shift the air intake selection switch to “fresh air (external air)”.

Please refer to the related description in the “Operating Tips” afterwards for the setup of vent

control knob.



Internal/external recirculation button

Press the left or right button on the top of the panel to select the air source.

1. Recirculated air – Air recirculation in the car.

2. Fresh air – Intake of external air.

A/C switch button

Press “A/C” button to turn on the A/C. In such case, the indicator lamp of “A/C” button goes on. Press this button again to turn off the A/C.

Air flow illustration of vent control knob

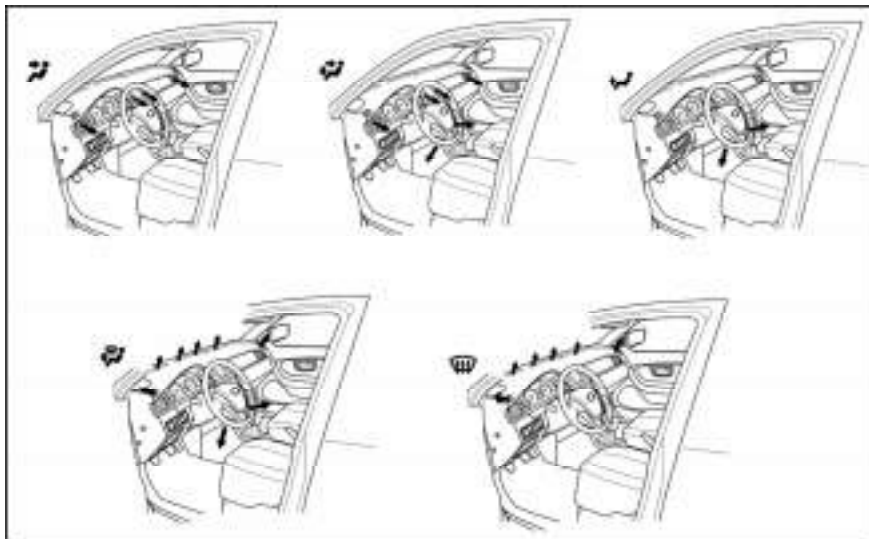

Operating tips

- 1.To rapidly cool down the car after exposure to the heat of the sun, turn off the A/C, open the windows and drive for a while to drain the hot air. Then, turn on the A/C so that the air in the car will be cooled down very faster.
- 2.Make sure that the air inlets in front of the windscreen are not blocked (by leaves, snow and etc.).
- 3.In humid weathers, do not blow cold air towards the windscreen, or the windscreen will have mist formation due to temperature difference between inside surface and outside surface.
- 4.Make sure that the area under the front seats is free of obstruction, in order to help the air flow in the car.
- 5.In cold weathers, shift the fan speed to “Hi” position for a while to help remove the snow or water from the ventilation pipe, which can

reduce the frost or mist formation on the windows.

6.When traveling on the road with heavy dust, close all windows. If the dust still can enter into the car after all windows are closed, maybe the air intake selection switch is shifted to “Fresh air” and the fan speed selection knob is placed at the position other than “OFF”.

7.When traveling on the road with heavy dust on the heels of other cars or traveling in windy condition with heavy dust, it’s recommended to shift the air intake selection switch to “Recirculated air” temporarily, which can cut off the passage with outside and prevent the ingress of external air and dust into the car.

Warming up

To achieve the best effects, place various control switches to:

Fan speed – Any position other than “OFF”.

Temperature selection – Point to “Warm” (red area).

Air intake – “Fresh air” (external recirculation).

Vents – “Floor vents”.

A/C – “OFF”.

- To warm up rapidly, use the “Recirculated air” for a while. When the air in the car gets warm, shift to “Fresh air” in order to prevent the mist formation on the windows.
 - Press the “A/C” button and shift to “Warm up and dehumidify” mode.
 - Shift the vent control knob to “Floor/windscreen vents” so that the air flow warms up the air in the car as well as defrosts or demists the windscreen and front windows.
- A/C

To achieve the best effects, place various control switches to:

Fan speed – Any position other than “OFF”.
Temperature selection – Point to “Cold” (blue area).
Air intake – “Fresh air” (external recirculation).
Vents – “Instrument panel vents”.
A/C – “ON”.

- To cool down rapidly, select the air intake selection switch to “Recirculated air” for a while.

Ventilation

To achieve the best effects, place various control switches to:

Fan speed – Any position other than “OFF”.
Temperature selection – Point to “Cold” (blue area).

Air intake – “Fresh air” (external recirculation).
Vents – “Instrument panel vents”.
A/C – “OFF”.

Demisting and defrosting

Inside of windscreen and front window glasses:

To achieve the best effects, place various control switches to:

Fan speed – Any position other than “OFF”.
Temperature selection – Point to “Warm” (red area).
Air intake – “Fresh air” (external recirculation).
Vents – “Windscreen vents”.
A/C – “ON”.

- In humid weathers, do not blow cold air towards the windscreen, or the temperature difference between

the outside and inside of the windscreen will lead to more serious mist formation.

Outside of windscreen and front window glasses:

To achieve the best effects, place various control switches to:

Fan speed – Any position other than “OFF”.
Temperature selection – Point to “Warm” (red area).
Air intake – “Fresh air” (external recirculation).
Vents – “Windscreen vents”.
A/C – “OFF”.

- Shift the vent control knob to “Floor/windscreen vents” to warm up the air in the car as well as defrost or demist the windscreen and front window glasses.

Center vent and side vents



In event of unfavorable air rate from the vents, please check the central vents and side vents. The central vents and side vents may be at open or close status, as shown in the figure.

Cigarette lighter and ash tray

Cigarette lighter

Firstly press the ashtray cover in the center of the instrument panel.

To use the cigarette lighter, push down the cigarette lighter. Once heated, it will automatically pop up

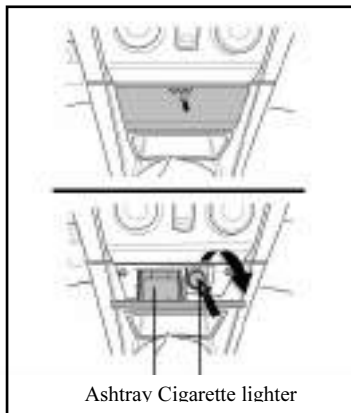

To use it while the engine is not running, shift the key to “ACC” position.

During the replacement, make sure to use the Designated workshop genuine cigarette lighter.



Warning

- Do not push down and always hold the cigarette lighter, or it will get overheated to result in fire.
- Do not connect to other electric appliances.

Ashtray

To use it, press the ashtray cover in the center of the instrument panel. Completely extinguish the cigarette butt before putting into the ashtray, in order to prevent igniting other cigarette butts in the ashtray. After use, push back the ashtray cover to

the original position. To take out the ashtray, pull it upward.

 **Warning**

To lower the accidents during traveling or sudden stop from causing personal injuries, close the ashtray cover after using the ashtray.

— **Glove box**

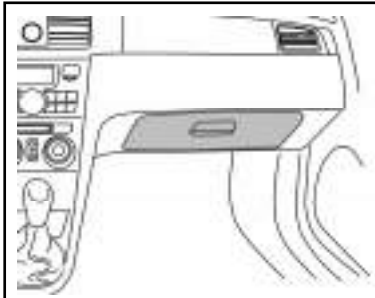

To use the glovebox, pull outward the handle.

 **Warning**

To lower the accidents during traveling or sudden stop from causing personal injuries, close the glovebox cover during the traveling.

— **Cup holder**

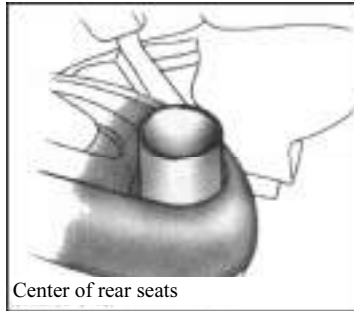

Center of rear seats

The cup holder located on the passage box is designed to safely place the cup or beverage can into the recess.

 **Warning**

Do not place the objects other than cup and beverage can into the cup holder, in order to prevent them from throwing and causing personal injuries in event of sudden brake or accidents.

—ISS (Idle Start/Stop System) operation instructions (if equipped)

Notes for ISS (Idle Start/Stop System)

Idle Start/Stop System (hereinafter referred to as ISS) shuts down the engine automatically when waiting for traffic signal or parking for a short time, then starts the engine automatically according to the driver's operation to save fuel.

Function Description

Idle Stop Function

When the vehicle stops, the engine computer stops the engine based on determination of comprehensive conditions.

Operating conditions: transmission gear is at "neutral" position natural, and release clutch pedal.

1. When any of the following items occur, even when operating

conditions are met; the engine will not stop automatically.

- ◆ A/C is in working state.
 - ◆ Air outlet control knob on A/C control panel is rotated to windshield defogging position.
 - ◆ Driver is stepping on the accelerator pedal.
 - ◆ Engine hood is opened.
 - ◆ Idle Start/Stop Cancel Switch is turned on.
 - ◆ After the previous idle start/stop, if the vehicle speed is less than 3 km/h or the time from the previous idle start/stop is less than 8 seconds.
 - ◆ Negative pressure of braking is too low (less than 65KPa).
 - ◆ Engine water temperature is too low.
 - ◆ Battery temperature is too low (below 0°C).
 - ◆ Battery power is too low.
- The above items are abnormal. After driving for a period of time

(driving time depends on detailed conditions of the vehicle). According to the driver's operation, the engine stop function restores normal state.

Restart Function at Idle Speed

In idle stop, step on clutch pedal to start the engine.

In addition, even if you do not step on clutch pedal, when the above items occur, the engine will restart automatically.

- ◆ Turn on A/C switch.
 - ◆ Air outlet control knob on A/C control panel is rotated to defogging position of the windshield.
 - ◆ The vehicle slips (vehicle speed is above 3km/h).
 - ◆ Step on brake pedal several times.
 - ◆ Engine stop exceeds a certain period.
 - ◆ Battery power is not enough.
- The above-mentioned items are for

the sake of the driver safety or comfortableness. They are normal.

Idle Start/Stop Cancel Switch



Idle start/stop cancel switch is installed on the left side of the instrument panel. Press idle start/stop cancel switch to cancel idle start/stop function. At the same time, the ISS indicator lamp in the combination instrument will go out.

Press it again to enable idle start/stop function immediately. The ISS indicator lamp will light.

Suggestion
In high-elevation area (above 2000m), ISS system function will be invalid. It is suggested that the driver use idle start/stop cancel switch to close ISS system.

ISS Indicator Lamp

ISS system working state can be determined by ISS indicator lamp on combination instrument. For ISS indicator lamp positions, see Combination Instrument.

ISS Lamp State	Description
Indicator lamp goes out	ISS Function Disabled

Green ISS lamp is lit	Allow the engine to enter into idle stop and restart state.
Yellow ISS lamp is lit	The system has no fault, but the engine is not allowed to enter into idle stop state.
Yellow ISS lamp flashes	ISS system has a fault.

Note
If any of the above-mentioned items occurs, it is required to go to local <u>Designated workshop</u> for check or repair.
◆ Yellow ISS lamp is lit for a long time.
◆ Yellow ISS lamp flashes.

Buzzer

The buzzer is installed in combination instrument. When ISS function is working (engine stop is being handled, the engine is being stopped or restarted), once specified operation condition occurs, the buzzer will buzz for alarming.

Buzzer prompt tone description

1. Continuous Buzzing

When ISS function is working (engine stop is being handled, the engine is being stopped or restarted), if any of the following items occurs, the buzzer will buzz for alarming.

- ◆ Front engine hood is opened.
- ◆ ISS system is detected to have a fault code.
- ◆ When restarting, the engine cannot be started.
- ◆ Without operating clutch, transmission gear is not in neutral position.

Now the engine cannot start

automatically. It is required to use the key to start the engine.

2. Continuously Intermittent Buzzing

When the engine is being stopped under ISS function, transmission gear is away from neutral position and the buzzer will buzz intermittently. After the gear is put back to neutral position, the buzzer will stop buzzing. (After the gear is put into natural position, step on the clutch to start the engine).

But during the course of intermittent buzzing, once control conditions for starting the engine occur, the buzzing will become continuous. On that occasion, under ISS function, engine restart function will be disabled. The key is required to start the engine.

3.3 times of intermittent buzzing

Under ISS function, the engine is being stopped, in order to charge the battery, the engine may restart

automatically. In this case, three times of intermittent buzzing will be sent.

Note
◆ ISS system function is affected by many factors, including driver's operation, engine state, battery state, environmental factors etc. Therefore, after the engine is started with the key, maybe ISS system function will work after a period of time.
◆ If the vehicle is not used for a long time, ISS system will not stop or start the engine due to low power of the battery. In this case, it is necessary to charge the battery. Before ISS function can work normally, please use the key to start the vehicle.
◆ At low outdoor temperature, if the vehicle goes into idle stop

state, air temperature from the blower may be too lower. At the same time, when the driver uses the heater mode, if the vehicle goes into idle stop function, the blower will blow out the air that the temperature is low. Because outdoor temperature is too low, the vehicle may not go into idle stop state with the resistance inside the battery increasing.

◆ If the battery that is not genuine is used on the vehicle, the performance of idle stop system cannot be ensured.

◆ When the starter, fuel pump and engine computer have a fault or starting times exceed the provision, the value of starting times in the system shall be cleared while replacing related parts. Starting times of the above parts exceed the specification, ISS function will be disabled, yellow ISS lamp is normally on.

Chapter 2

Driver Notices

—Break-in period

To moderately drive the automobile, and high-speed driving is not allowed.

Fine run-in is not necessary to new vehicle, but the following essentials during the first 1600km running process can help improve automobile's economic performance and prolong its service life.

- Speed stays below 100km/h.
- Engine maintains moderate rotary speed: 2000 r/min to 4000 r/min.
- Full-throttle start is not allowed.
- Do not slam the brake during the first 300km mileage.

- Do not drive at moderate speed through high gear
- Do not drive for a long time through the same high gear or low gear

—Fuel

To select appropriate fuel, in order to improve engine performance.

Other fuels beyond the manual may result in engine damage.

Fuel type

Only vehicle-used lead-free gasoline is allowed.

Rated capacity of fuel tank is 37L.

Notice
Lead gasoline is forbidden, because it will lead to three-way catalytic converter's failure and emission control system's abnormal running as well as engine maintenance fees' increase.

Octane number

To only adopt No.93 research octane number and vehicle-used lead-free gasoline.

The fuels with octane number below the stipulated number will lead to continuous piston knock even engine damage.

Engine knock

Please enquire Designated workshop in the event that there are piston knocks while using stipulated fuels or while driving on even road at stable speed.

It is normal if there are short-term and light piston knocks while the vehicle is accelerating or climbing slopes.

—Three way catalytic converter (TWC)

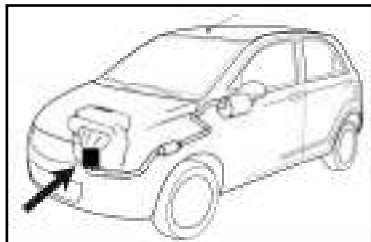

Three-way catalytic converter is the

emission control facility installed on the emission system, and it is used to reduce the pollutants in exhausted gases.

Warning

- While engine is running, people and inflammable articles should keep away from the vent-pipe, because the emitted gas is very hot.
- Do not drive, idly run, or park the automobile on flammable articles (like grass, leaves, paper, or rag).

Notice

Lots of unburned gases' flow into three-way catalytic converter may lead to overheating or fire disaster, thus you should adopt the following countermeasures:

- ◆ Only use lead-free gasoline
- ◆ Do not use low-quality fuel, because unqualified fuel may result in engine start failure, as well as add additional burden to three-way catalytic converter.
- ◆ Do not put the vehicle into idle run for over 20 minutes.
- ◆ Do not drive at excessive speed.
- ◆ Do not start the automobile by pushing or pulling ways.
- ◆ Do not shut off the ignition switch while automobile is running.
- ◆ To assure that the engine is running according to normal command. Troubles in engine's electrical control system, ignition system or fuel system may result in the overheating of three-way catalytic converter.

◆ In the event that engine can't be started or the engine always pauses, you should conduct troubleshooting as soon as possible. Please remember that Designated workshop understand most clearly your car and its three-way catalytic converter system.

◆ To assure the normal running of three-way catalytic converter and the entire emission control system, automobile should be regularly examined according to the requirements of maintenance schedule.

—Engine emission precautions

Warning

- Do not suck the exhaust gas, because it contains carbon monoxide. Carbon monoxide is a kind of noxious, colorless, and odorless gases, and it can lead to shock even death.
- To assure no leakage or disconnection of emission system and regularly examine the system. In the event of collision or abnormal sound, you should immediately examine the system.
- Do not start the engine in garage or enclosed areas, because the emitted gas can not diffuse, which will cause danger.
- Do not run engine for a long

time after parking the automobile. If necessary, the engine should be started at the broad area, with heating system or refrigerating system being regulated for compulsive ventilation.

- To shut off the trunk, otherwise the exhaust gas will be sucked into the automobile.
- To make full use of ventilation system and assure that there is no snow, leave, or other articles at inlet opening in front of wind screen.
- In the event that you smelt the smoke in the car, you should open the windows and shut off the back door, in addition to locating the troubles and adopting countermeasures.

—Information about engine oil consumption

Function of engine oil

Engine oil can be used to lubricate and cool the engine inside, and it plays significant role in engine maintenance.

Consumption of engine oil

Engine will consume oil while running, and the reasons for engine oil consumption are shown as follows:

- Engine oil is mainly used for lubricating piston, piston ring, and gas cylinder. In the event that the piston is moving downwards, a thin layer of oil film will be formed on the wall of gas cylinder, and high negative pressure will suck above-mentioned engine oil into combustion chamber while decelerating. Later, such engine oil

and some engine oil film on the wall of gas cylinder will be burnt by high-temperature inflammable gas in combustion stroke.

- In addition, engine oil can be used for lubricating intake valve spindle. Some engine oil and air will be sucked into combustion chamber, and they will be burnt together with fuel. Also, the engine oil for lubricating intake valve spindle will be burnt by hot gas.

Engine oil consumption depends on engine oil's stickiness & quality and automobile's running condition.

More engine oil will be consumed in the event of high-speed running and frequent acceleration & deceleration.

New engine will consume more oil due to poor run-in among piston, piston ring, and gas cylinder.

Consumption of engine oil: the maximum value: 0. 9L / 1000km.

While calculating engine oil consumption, it is noteworthy that engine oil can be diluted, which poses difficulty to calculate the actual oil consumption.

For instance, in the event that automobile is repetitively running in a short distance but engine oil consumption is normal, engine oil level does not decline according to dipstick, and engine oil level maintains unchanged after running above 1000km, which should be attributed to engine oil's dilution by fuel or water.

While automobile is running at high speed (such as in expressway), the diluted elements will be vaporized, thus engine oil's excessive consumption will be displayed on the dipstick.

Importance of examining engine oil level

To assure engine oil's normal

functions, engine oil should stay at the optimal level, which is one of key contents for automobile maintenance. Therefore, you should regularly and prudentially examine engine oil level.

Notice

Insufficient engine oil level may result in severe engine troubles.

Please see 7-2 “Examination of Engine Oil Level” for detailed information concerning engine oil level examination

— Brake system

Brake system is a double-loop hydraulic system (X layout) equipped with series brake master cylinder. In the event that one loop failed, the other loop can still run.

However, brake pedal travel will increase, and brake distance will accordingly be lengthened, and brake warning light will be lightened.

Warning

●Do not drive while only one brake loop is running and repair the brake system as soon as possible.

Vacuum strengthener

Vacuum strengthener takes the vacuum from engine inlet manifold as the strengthening source. In the event of engine cutoff during the running process, vacuum in vacuum strengthener can assure one-time or twice brakes through ordinary pedal force.

Warning

- Do not depress the brake pedal while the engine does not work, otherwise the vacuum force in vacuum strengthener will be exhausted.
- Even if the strengthening force is lost completely, the brake is still valid, but pedal force is comparatively larger, which leads to the increase of brake distance.

Antilock brake system (ABS) (if equipped)

ABS is designed for guarding against tire lock in the event of urgent brake or brake on smooth roads, and it helps greatly improve automobile brake system’s stability and maneuverability.

Effective method for depressing brake pedal:

To fully depress the brake pedal in

the event that the ABS is running, especially urgent brake. Do not repetitively depress the brake pedal, in order to guard against brake distance's increase.

ABS will run while the speed is accelerated to 10km/h, and it will stop working while the speed decreases to 5km/h.

In the event of brake on smooth roads or on rainy days, ABS will work. While starting engine or engine has been just started, you may hear the click sound or motor sound arising from engine compartment, which implies the ABS's self-inspection instead of troubles.

In the event that ABS is working, the following cases may take place, but they do not mean troubles.

- You may hear the sound of ABS working and feel that the brake pedal & steering wheel are

vibrating. In addition, you may hear the motor sound arising from engine compartment while the automobile is parked.

- At the end of ABS working, the brake pedal may slightly move downwards.



Warning

Do not overvalue the ABS, though ABS is favorable for automobile control. However, careful drive, appropriate speed, and safe space are still important, because automobile brake's stability and steering wheel's maneuverability are limited even through ABS is working. In the event that the brake force is beyond the tire's control ability or hydroplaning takes place due to high-speed running on rainy days, ABS fails to effectively control the automobile. ABS is

not designed for shortening brake distance, thus it is a must to drive at appropriate speed and keep safe space from front vehicles. Compared to automobiles without ABS, the automobiles equipped with ABS may need longer brake distance in the following cases:

- To drive on coarse roads, gravel roads, and snowy roads.
- To drive across sidesteps, such as the junction of roads.
- To drive on the rough roads.

Tires with designated size and designed pressure should be installed on the four wheels, and ABS leverages wheel speed sensor to inspect each wheel's rotary speed, in a bid to measure automobile's speed. Unqualified wheels will lead to inaccurate wheel rotary speed and overlong brake distance.

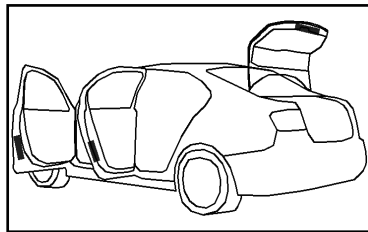
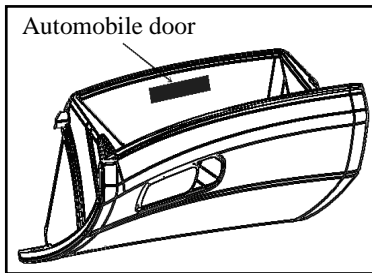

— **Vehicle identification (vehicle identification number)**

VIN serves as the legal identifier of automobile, Its position is shown as the diagram below :

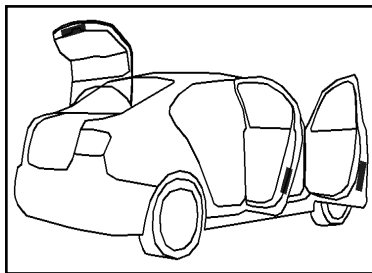

The exposed metal plate of inner plate of front left & right automobile door

The exposed metal plate of inner plate of back left & right automobile door

The surface near luggage-boot lid region

Vehicle identification number (VIN) is the legal identifier of automobile. It is an important identification code to your automobile and is used for registration of your automobile.

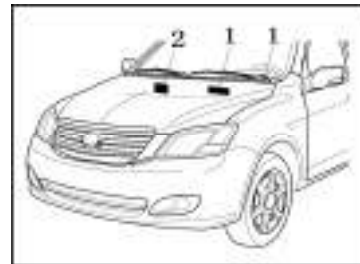

VIN engraved code.
VIN brand name and vehicle name-plate

—Luggage placement notices

To abide by the following principles while placing luggage to the car:

- Articles should be safely placed in the event that there are lots of luggage or articles in the car.
- To maintain car balance and put the heavy articles in the front of the car, which is conducive to maintaining balance.
- Do not place unnecessary heavy articles, in order to reduce fuel consumption.

Warning

●Do not pile the articles higher
Vehicle identification number (VIN) engraved code is engraved

Vehicle identification number (VIN) engraved code is engraved in middle inclined left of front wall upper plate in engine compartment, as the position shown in diagram 1

There is vehicle identification number (VIN) on automobile nameplate, the position being middle deviated to right in inner front upper wall, as the position in diagram 2

Vehicle identification number (VIN) nameplate is erected at top left corner of instrument board, as the position shown in diagram 3
VIN tagboard

than the backrest of rear seats and luggage should be placed close to the floor, in order to prevent luggage or package from sliding forwards.

●Passengers are forbidden to sit in the trunk, which is not designed for passengers.

Passengers should sit in the chairs and correctly fasten the safety belt, otherwise they will be hurt due to sudden brake or collision.

●Do not put any article on the cover behind rear seat's backrest, in order to guard against personal hurt due to sudden brake or accidents.

●Do not put articles on meter board while the car is running, which will exert influence on driver's vision. In addition, the articles will move in the event of sudden accelerating or swerving, which will influence driver's operation or hurt passengers during accidents.

—Subsidiary operating limits of brake friction

Operating limit of brake disc and friction plate

The minimum allowable thickness of brake disc after polishing is 10mm

The minimum allowable thickness of friction plate is 1mm

Operating limit of drum brake and friction plate

The maximum allowable diameter of drum brake after polishing is 181mm

The minimum allowable thickness of friction plate is 1mm

Braking lining limit wear alarming plate

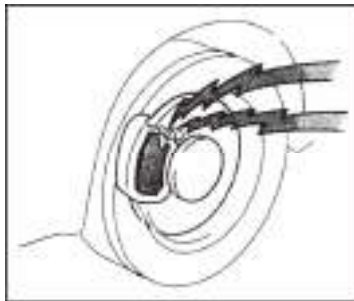

In the event that front brake lining needs to be replaced, limiting wear warning pieces will contact with brake disc, with metal sound being generated.

During automobile running process, you should examine or replace the brake lining in the event that you hear squealing or scraping sound.

Do not continue driving after hearing warning sound.

In the event that you continues driving without replacing brake lining, the brake disc will be

severely damaged, and brake pedal travel will increase and reach the same brake distance.

—Electric power steering system (EPS) (if equipped)

EPS is used to reduce the required force of turning steering wheel

Notice

- You may hear motor working sound (buzz) while operating steering wheel, and such sound is normal.
- While frequently turning steering wheel for a long time, EPS efficiency will decline for guarding against system overheating, thus steering wheel will get heavy. Therefore, drivers should not frequently turn steering wheel or shut off engine while parking the car.

Engine number

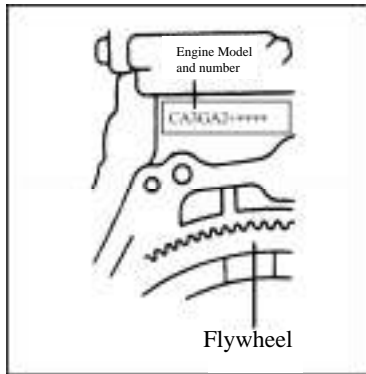

CA3GA2+engine

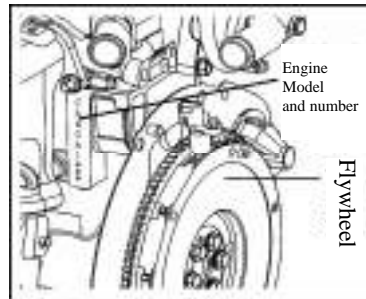

CA4GA1 engine

The engine number is carved on the place marked in above figure of engine cover.

Chapter 3

Start and Drive

——Before starting your engine

- 1.To inspect automobile body before entering the car.
- 2.To regulate seat location, backrest angle, head pillow height, and steering wheel angle.
- 3.To regulate internal and external rearview mirrors.
- 4.To lock all doors.
- 5.To fasten the safety belt.

——How to start your engine

- (a)Prior to start

- 1.To pull the brake handle upward
- 2.To turn off unnecessary lights and accessories.

3.To depress clutch pedal until engine is started and convert gear to neutral position.

(b)Engine start

To operate according to the requirements in“(a) Prior to start” before starting the engine.

Usual start procedures

Multi-point Fuel Injection System can automatically control the air-fuel ratio during engine start process, and drivers can conduct cold start or hot start through the following method.

- 1.To turn ignition switch key to “START” for starting the engine and release the key after the engine has been started, with accelerator pedal not being depressed during the process.

2.To start up the automobile after the engine has run for 10 seconds. To warm up the engine prior to drive in the event of cold weather.

Engine kill

To restart the engine according to the ordinary procedure.

Engine start failure

Please refer to relevant contents in Chapter IV “Engine start failure”.

Notice

- ◆ The start should not last for over 10 seconds, which will lead to overheating of engine and wiring system.
- ◆ Engine's rotary speed should not be over-high in cold state.
- ◆ To immediately examine and repair the engine in the even of engine start trouble or frequent engine kill.

—Safety inspection before departure

It is important to conduct safety examination prior to drive, which will assure safety and pleasant drive. It is a must to have full knowledge to automobiles, which is regarded as a prudential opinion. Therefore, you must regularly examine your

automobile at *Designated workshop*.



Warning

To assure sufficient ventilation in the event of examining automobile in sealed garage, because the exhaust gas emitted from engine is toxic.

Prior to engine start Automobile outside

Tire: to inspect tire pressure through pressure gauge and carefully check if tire is lacerated, damaged, or over worn.

Wheel: to assure that nuts have not missed or loosened.

Liquid leakage: To check if fuel, engine oil, water, or other liquids at the bottom of vehicle are leaked (water leakage from air conditioner is normal).

Lamps: To assure head lamp, brake

lamp, tail lamp, turn signal lamp, and other lamps should be in normal work, as well as examine head lamp's lightening direction.

Automobile inside

Spare tire, jack, and wheel nut spanner: To check spare tire's tire pressure and assure that jack & tire nut spanner are equipped.

Safety belt: To check whether safety belt can be safely locked and assure safety belt has not been worn.

Meter and control switch: To assure the normal work of indicator lamps, meter lamp, and defrosting facility.

Brake: to assure brake pedal has sufficient clearance.

Engine counterpart

Spare fuse: to assure there is spare fuse

All fuses with designated rated

current should be installed on fuse box.

Coolant Level: To assure the accurate coolant level (please refer to relevant contents in 7-2)

Accumulator and connection wire: To check if accumulator terminal has been cleaned or loosened and if there is crack on accumulator, in order to assure the good connection of wires.

Wire harness: To check if the wire is damaged, loosened, or disconnected.

Fuel pipeline: To check if the pipeline is leaked or if the connection is loosened.

After engine start

Exhaust system: to hear if there is leaking sound.

To immediately repair in the event of leakage (please refer to relevant contents in Chapter II “Notices for

Engine Exhaust”).

Examination to engine oil: To park the automobile on a smooth place and shut off the engine, and then examine the engine oil level through dipstick (refer to relevant contents in 7-2).

During driving process

Meter: to assure normal work of speed meter and odometer.

Brake: To examine the brake system at the safe place, in order to assure sound brake performance.

Other abnormal cases?:

To check if there are component loosening or leakage and if abnormal sound can be heard? You can start your happy travel in the event of no any trouble.

——Driving tips in various situations:

- To reduce the speed in the even of horizontal wind, in order to effectively control the automobile.
- To decline the speed while climbing shortcut slope, with automobile keeping certain angle with shortcut slope, in order to guard against tire damage or flat tire due to knocking into high or sharp articles.
- To turn steering wheel until the front wheel is closed to the shortcut while parking on slope, which will help fix tire. Then, to tightly pull the hand brake and place the gear to the first gear or reverse gear, which will help wedge the wheel if necessary.
- While cleaning the automobile or driving across deep water, the brake shoes may be wetted. To check if

they are wetted, you can slightly depress the brake pedal on the road without of vehicle, and the brake shoes may be wetted in the event that you can not feel the brake force. At this time, you should be prudential in drive and slightly depress the brake pedal for drying the brake shoes. In the event that the vehicle still fails to safely work, you should park the vehicle on the roadside, and then you should ask the support from Designated workshop



Warning

- To assure the hand brake is completely released prior to automobile start, with caution lamp of brake system being shut off.
- Do not leave while engine is

running and no person in vehicle.

- Do not put foot on brake pedal during normal running, which will lead to brake lining's overheating and unnecessary abrasion as well as decrease of fuel economic performance.
- To reduce the speed and go into low gear while driving upwards or downwards the long & cliffy slopes. Automobile control through frequent brake will result in brake lining's abnormal running due to overheating.
- To be prudential while accelerating, going into high gear or low gear, or braking on smooth roads, because abrupt acceleration or engine brake may lead to automobile tail flick and slippage
- Do not continue driving automobile as usual after brake

shoes have been wetted, and brake shoes' wetting will lead to longer brake distance, and automobile lateral runout, or brake failure even by hand brake.

Notice

To fend off large loblolly while driving on wet road, because numerous water's entry to engine compartment may pose danger to engine and components.

—Driving tips in winter

Glycol coolant is usually used, which can guard against the erosion of aluminum components. Please refer to relevant contents in 7-2 concerning coolant type.

Notice

Do not use ethanol coolant or pure water.

In severe cold, solution with 60% of concentration is recommended, because its minimum use temperature amounts to -50°C . It is not recommended to adopt the solution with concentration above 70% for achieving better cooling performance.

Examination of accumulator and connection wire.

Low temperature will reduce accumulator's capacity, thus accumulator can supply sufficient power while being fully charged. 7-3 details how to examine accumulator from outline, and you can call Designated workshop for checking accumulator's charge condition.

To assure that engine oil's viscosity is adaptable for cold weather.

Please refer to the recommended engine oil viscosity in Chapter VIII. To use the summer engine oil in winter will lead to engine start failure. Please call Designated workshop for support in the event engine oil type.

Freeze resistance of door lock .

To paint door lock through antifreeze or glycerin, in order to guard against the freezing of door lock.

To utilize the washing liquid containing antifreeze.

The product can be purchased from Designated workshop and most of automobile parts stores, and the fixing proportion with water should be confirmed according to the requirements of manufacturer.

Notice

Do not take engine coolant or other substitutes as washing liquid, because they may damage automobile's oil paint.

Do not use hand brake if the hand brake might be frozen.

While the automobile is parked, gear should be placed at first gear or reverse gear for wedging the wheel. In addition, hand brake should not be used, in order to prevent the hand brake from being frozen by snow.

To guard against ice and snow accumulation at the bottom of wheel cover.

While driving in bad weather in winter, ice & snow may be accumulated at the bottom of wheel cover, which may result in drive trouble, thus drivers should occasionally examine the automobile and clean up the ice &

snow at the bottom of wheel cover.
 We recommend that some emergent equipments should be carried according to different roads.
 The following tools can be carried: window scraper, sandbag or salt bag, flash lamp, shovel, and jumper wires, etc.

——Trailer towing

The vehicle is not designed for the installation carriers of trailer or traipsing facility, thus our company recommends you not to use your trailer and not to install traipsing facility.

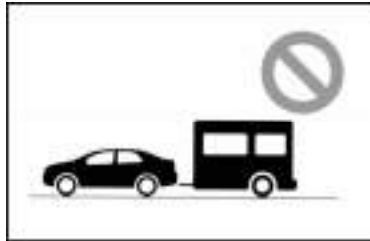

——How to save fuel and increase driving range of your car

It is easy to increase the mileage of each liter fuel, which is favorable for prolonging automobile's service life. Contents below detail how to save money in fuel and maintenance:

- To maintain tire's charge pressure at designated pressure.
 Insufficient charge pressure will lead to tire abrasion and fuel waste. Please refer to relevant contents in

7-2.

- Do not install unnecessary heavy articles in the automobile.
 Overweight will increase engine load and increase fuel consumption.
- To guard against overlong idle running
 Once engine running become stable, you can smoothly start the automobile. However, the idle running needs a long time in winter.
- Stable acceleration
 To guard against rough start and do not go into high gear at a fast speed.
- To guard against engine's overlong idle running
 You'd better shut off the engine in the event of long-time waiting beyond vehicle flow.
- Guard against excessive fast rotary speed due to engine towing.
 To adopt appropriate gear while driving.
- To guard against abrupt

deceleration in the wake of frequent acceleration.

Discontinuous running will result in fuel waste.

- To guard against unnecessary parking and brake.

To drive at stable speed and reduce brake & parking as much as possible. In addition, to keep appropriate space from other vehicle, in order to guard against abrupt brake, which can help reduce brake shoes' abrasion.

- To avoid traffic jam as much as possible.

- Do not always put the foot on clutch or brake pedal, which may lead to clutch disc and brake lining's unnecessary abrasion, overheating, and fuel waste.

- To maintain appropriate speed

Drive at high speed will result in excessive fuel consumption and deceleration will help save fuel.

- To clean up the sundries (like soil) at the bottom of automobile, which will help reduce weight and guard against erosion.

- To keep automobile in good condition.

The following factors will reduce engine performance and increase fuel's consumption: unclean air filter, coupling hose's joints, circuit plugs, engine oil, and lubricant, inappropriate valve clearance, and unregulated brake.

To prolong components' service life and reduce running cost, drivers should conduct regular maintenance & examination to automobile, especially after long-term running in bad weather.



Warning

Do not shut off engine while running from slope, because the strengthener in brake system will not run while the engine fails to run. In addition, exhaust control system will be in normal running only when the engine is running.

Chapter 4

Emergency Handling

—In case your car fails to start up

(a) Simple examination

Prior to any examination, please check if your start procedure is consistent with the procedure in Chapter III “How to start engine” and if the fuel is sufficient.

Engine fails to rotate or rotate slowly

1. To check if accumulator wire post is firmly connected and if it is clean.
2. To turn on indoor lamps in the event of sound accumulator wire post.
3. Indoor lamp is off during engine running, implying that accumulator

lacks electricity. In this case, you can adopt the method of “lapping start” to start the engine. Please refer to “(c) Lapping start” for detailed information.

In the event that indoor lamp is normal but the engine still fails to start, you should regulate or repair the automobile or call *Designated workshop* for support.

Notice
Do not adopt pushing or pulling way to start automobile, which may result in automobile damage, accident, or fire disaster due to three-way catalytic converter's overheating.

In the event that engine can be started at normal rotary speed but it is unable to run normally.

1. To check if all parts are firmly installed (such as spark plug and sparking coil, etc.)

2. In the event that all parts are normal, the abnormal running of engine should be attributed to excessive oil in spark plug due to repetitive start. Please refer to “Engine start in the event of immersed spark plug”

(b) Engine start in the event of immersed spark plug

Engine start failure should be attributed to excessive oil in spark plug due to frequent start.

In this case, you should put key at

“START” place for 10 seconds while depressing accelerator pedal, and then you should attempt to start engine on the precondition of not depressing accelerator pedal.

In the event that you still fails to start the engine within 10 seconds, please take out the key and attempt to start the engine several minutes later.

In the event that you still fails to start the engine, you should regulate or repair the engine, and you can call Designated workshop for support.

Notice

Do not continue starting the engine for over 10 seconds, which may lead to overheating of engine or circuit system.

(c)Lapping start

In the event of power failure, you

can start the engine through the accumulators in other vehicle.

To guard against accumulator explosion, acid scalding, electrical burning, or damaged electric components' danger to people & vehicle, you should strictly follow the rules below:

You should enquire Designated workshop in the event that you have little knowledge to the implementation of the following rules.



Warning

- Accumulator electrolyte contains noxious substances and erosive vitriol.
- To wear protective spectacles while conducting lapping start, and to prevent vitriol from splashing on skin, clothes, or vehicle.

● In the event that acid splashes on clothes or eyes, you should put off your clothes and clean eye with water, and then you should go to hospital for medical treatment. If necessary, you should wash the hurt place through cotton cloth or sponge.

● In the event that fire or spark is closed to the accumulator, a kind of gas will be emitted, which will lead to gas explosion. Therefore, only lapping cables should be adopted for lapping start, smoking and fire are forbidden during the process.

Notice

Accumulator voltage for lapping start should stay at 12V, and lapping start can be conducted after confirming that accumulator voltage is normal.

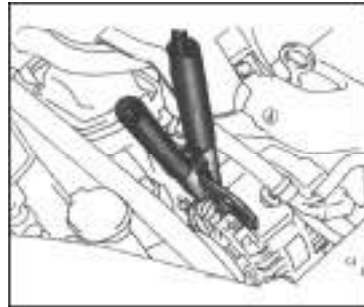
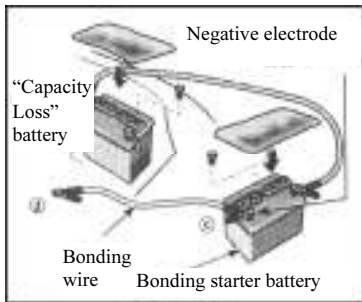
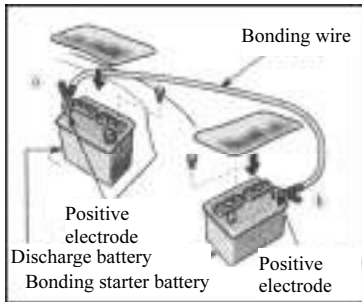

Rules for lapping start:

1. In the event of adopting the lapping start accumulator in other vehicle for lapping start, you should assure the two vehicle have not contacted and shut off all unnecessary lamps & accessories.
2. To pull out all breather plugs of lapping start accumulator if necessary, and then to cover the breather hole through cotton cloth, in order to guard against accumulator explosion and

personnel injury, etc.

3. To connect wires according to the following order:

a. To connect the first lapping wire's one terminal with accumulator's positive terminal (+).

b. To connect the first lapping wire's other terminal with accumulator's positive terminal (+).

c. To connect the second lapping wire's one terminal with accumulator's negative terminal (-)

d. To connect the second lapping wire's other terminal with stable & naked metal parts of discharged vehicle.

Lapping points are shown in figure below.

Do not connect lapping wire with moving parts or near to moving parts.

4. To start the vehicle equipped with lapping start accumulator and make

the engine rotate at 2000 r/m speed.
5.To start the vehicle equipped with accumulator and slightly depress he accelerator pedal after starting the engine, in order to make engine run at 2000 r/m speed for several minutes.

6.To disconnect lapping wire according to the reverse order of wire connection.

In the event that there is no remarkable reasons for accumulation discharging (such as light on), you should immediately call Designated workshop. For overhaul.

——In case your engine shuts down during your driving

You should make the following countermeasures in the event of

engine kill during running process:

1.To stably reduce the speed and maintain linear running, and then to park the vehicle at a safe place.

2.To turn on the hazard warning signal lamp

3.To attempt to restart the engine.

In the event of engine start failure, you should refer to relevant contents in Chapter IV “Automobile start failure”.

 **Warning**

In the event that the engine stops running, the strengthener in brake system will temporarily lose efficacy. In this case, brake is more difficult than in ordinary condition.

——In case your engine overheats

In the event that engine coolant temperature meter displays overheating of engine or engine power is lost according to experience or there are piston knock & pinging noise, the engine may be overheated, and you should take the following countermeasures:

1.To stably park the vehicle at a safe place, open hazard warning signal lamp, place gear at neutral gear, and tightly pull hand brake, in addition to turning off air conditioner.

2.In the event that coolant or steam are spurted from radiator or storage tank, you should park the vehicle and open the vehicle cover if there is no steam. In the event of no coolant or steam, you should maintain engine’s normal running on the precondition of cooling fan’s

normal running, otherwise you should turn off ignition switch.

 **Warning**

Due to high temperature of squirted coolant and steam, you should open cover in the event of no coolant and steam, in order to guard against personnel injury.

3.To directly observe if engine driving belt is damaged or loosened and if there is coolant leakage from radiator, flexible tube of cooling system, and vehicle bottom. In addition, to observe if the water discharged from air condition is normal.

 **Warning**

During engine running process, hands, hair, and clothes should keep away from the rotating fan and engine driving belt.

4.In the event that engine driving belt is damaged or coolant leakage takes place, you should immediately park the vehicle and call Designated workshop for help.
5.In the event of no damage to engine driving belt or no coolant leakage, you should inspect storage tank. In the event that the storage tank is dry, you should add coolant to half storage tank on the precondition of engine's normal running.

 **Warning**

Due to the radiator's internal pressure, the heated coolant or steam will hurt people, thus you should not open the radiator cover while the engine and radiator are heated.

6.In the event that engine coolant's temperature declines to normal temperature, you should check storage tank's liquid level and add coolant to half storage tank if necessary. The much loss of coolant implies the leakage of cooling system, thus you should call Designated workshop for overhaul as soon as possible.

—In the case of air leak from a tire

- 1.To firstly lower the speed stably and maintain linear running, and then carefully park the vehicle at safe and smooth hard place.
- 2.To shut off the engine and turn on hazard warning signal lamp.
- 3.To pull hand brake and place gear at reverse gear.
- 4.To learn about the following manuals.



Warning

To guard against personnel injury, you should follow the following notes while lifting automobile through jack:

- To strictly follow the operation manual for jack.
- Do not put any part of body

underneath the vehicle supported by the jack, which is dangerous.

- Do not start or turn engine while automobile is lifting through jack.

- Park the automobile on smooth and hard place, full hand brake, and place gear at reverse gear, in addition to wedging the tire on the diagonal of replaced tire.

- To assure that the jack should be placed on the accurate place of vehicle body, because improper place may result in vehicle damage, abnormal fall injury, and neighboring people injury.

- To assure no person in the vehicle while the automobile is hoisting.

- Do not put other articles on the top or bottom of jack while the automobile is hoisting.

- Automobile hoisting height should assure tire's smooth replacement.

- Do not start the engine while supporting the automobile through jack.

Notice

Do not continue driving in the event of flat tire, because continuous running may bring irreparable damage to tire.

Necessary tools and spare tires

2.Spare tire and tools

1)Jack handle

2)Hub wrench

3)Jack

4)Spare tire

5)Triangle warning sign

6)Aluminum alloy wheel decoration cover disassembly tools (if equipped).

Jack, Jack handle, hub wrench, wheel decoration cover disassembly tools (if equipped) should be put in workbasket and be installed on truck's spare tire cover, and the workbasket should be firmly connected with spare cover felt gasket through sticky button, in order to fix the workbasket.

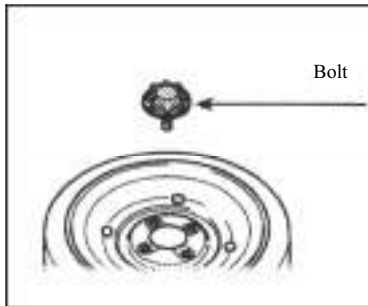

1.To take off the spare tire

- 1)To take off spare tire cover
- 2)To loosen bolt and take off spare

tire.

To take the spare tire out of the vehicle.

As to spare tire storage, you should firstly put the spare tire in place with outside downwards, and then you should fix the spare tire according to the reverse order of “taking off spare tire”, in order to prevent spare tire from flying off upwards in the event of crash or emergency brake.

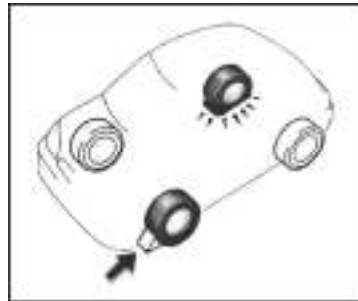

2.To wedge the wheel through chock

To wedge the wheel on the diagonal of flat wheel through block, in order to guard against wheel rolling while hoisting the wheel by jack.

While front wheel is wedged, block should be placed in front of front wheel and rear wheel should be placed in the front of rear wheel.

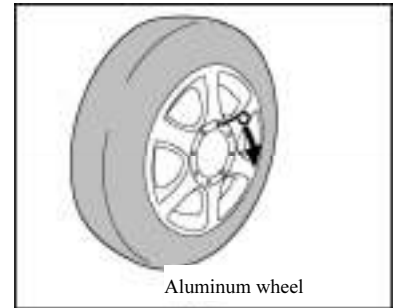

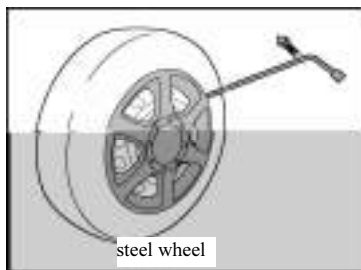

3.To dismantle wheel decoration cover

According to figure below, you should insert one terminal of dismantling tool into little holes near aluminum decoration cover for opening the cover. As to steel wheel decoration cover, you should leverage the inclined terminal of wheel wrench to open the cover.



Warning

Do not attempt to open the wheel decoration cover by hands

and the force should be moderate while opening the decoration cover, in order to guard against injury.



4.To loosen wheel nuts

Wheel nuts should be loosened before the automobile has been hoisted.

To loosen the nuts, wrench should be turned along counter-clockwise direction. To save labor, you should grab wrench handle terminal to raise the wrench upwards according

to figure below, and you should prevent the wrench from sliding from nuts.

Do not directly dismantle nuts and it is enough to loosen nuts to half and one circle.

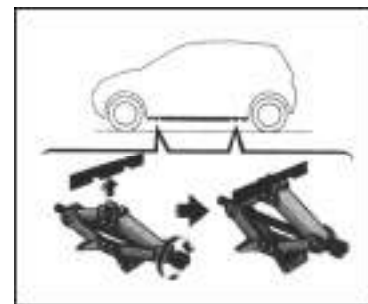

5.Jack placement

According to figure above, four jack support points at the bottom of automobile body are equally distributed on both sides.

Jack should be placed at the nearest

support point from the replaced tire. Jack must be placed on level and hard place, and one piece of wooden board can be placed underneath the jack if necessary.



6. Automobile Hoisting

After confirming that there is no person in automobile, automobile should be hoisted, and the hoisting height can assure spare tire's smooth installation.

Compared to flat wheel, spare tire's ground clearance is larger.

To hoist the automobile, you should firstly install jack handle, because jack handle can collaborate with hub wrench, and then you should turn the wrench along the clockwise direction. While jack is hoisting to the height of its contact point with automobile, you should reconfirm jack's installation point and support the automobile through fixed mount.

Warning

While supporting automobile through jack, you should not put any part of body under the automobile, and you should support the automobile through fixed mount after the automobile is hoisted through jack.

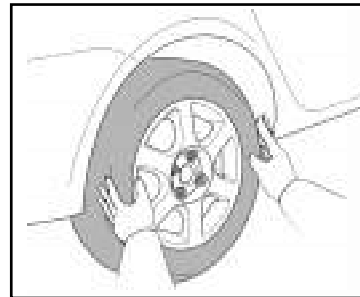

7. Wheel replacement

To directly dismantle the flat wheel. To roll the spare tire to the appropriate place and align the place of fixed bolt and wheel hole, and then make wheel to accurately aim at the top bolt. Finally, to make the wheel to aim at other bolts through turning wheel.

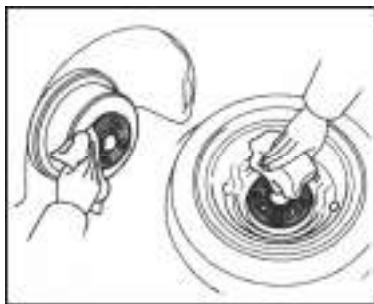

Prior to wheel installation, you should clean up the rust on the wheel surface through iron brush. During the process of wheel installation, in the event that no appropriate real metal is connected with metal on the installation surface, the bolt may loosen and wheel may fall off during automobile running process, thus you should check if binding bolt loosens after running for 1600km.

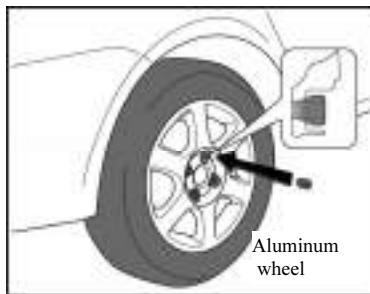
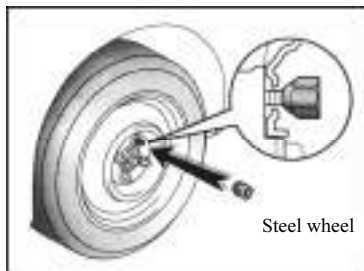

8. Installation of wheel clamp nuts

To install wheel clamp nuts (with cone face towards the inside) and screw down the nuts through hand.

While fixing the nut, hub nuts' cone face should contact with the cone face of wheel installation hole. After screwing down the nuts, you should push the wheel along external/internal directions, in order to check if clamp nuts can be further screwed down.

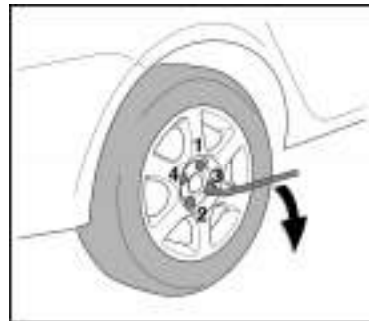

9. Lowering to original height

To turn the jack handle along counter-clockwise direction, in order to lower the automobile to

original height.

You should leverage hub wrench to turn clamp nuts along clockwise direction through hands instead of hammer and turn wrench by means of lengthening casing pipe or pedal, with wrench being reliably knotted on nuts.

Each nut should be screwed down for several times, and the screw order is shown in figure below.



Warning

To prevent operator or other persons from being injured during the process of lowering to original height.

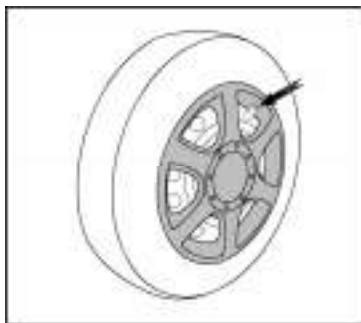

10.Re-installation of wheel decoration cover

- 1)To align the previous place of the wheel decoration cover. As to steel wheel, to align the positioning initial cuts on decoration cover and rim section.
- 2)To knock on decoration cover by fist or palm to the original place.



Warning

The force should be appropriate while installing wheel decoration cover, in order to guard against injury.

11.Examination of new tire's pressure

To regulate tire pressure to the designated scope in Chapter VIII. In the event that tire pressure is too low, to drive the automobile at low speed to the neighboring repair station, in order to supplement the gas to standard scope.

Do not forget to install valve cover after regulating the pressure, otherwise dirty articles or steam will enter the valve core and result in leakage. In the event of valve cover loss, please purchase a new one as soon as possible.

12.To tidy up all tools, and flat wheel.

In the wake of wheel replacement, you should screw down wheel nuts through torque wrench and then find technician to repair the flat wheel.

Warning

To carefully check if all tools, jack, and flat wheel have been put in place before driving, in order to prevent people from being injured due to crash or emergency brake. As to a new wheel, you must test its dynamic balance performance, making its residue unbalance $\leq 5g$ to prevent it from influencing automobile performance and accident.

—— **In case your car needs towing**

Traction through right equipment can assure no damage to automobile, because professional service personnel has more knowledge to regulations & rules concerning automobile traction.

Incorrect traction way will result in automobile damage, thus you should carefully read notices below. If necessary, you should show relevant contents to tractor driver.

Notices of automobile traction:

To adopt safe connection facility and follow local regulations & rules, with the wheel and axis staying in normal condition.

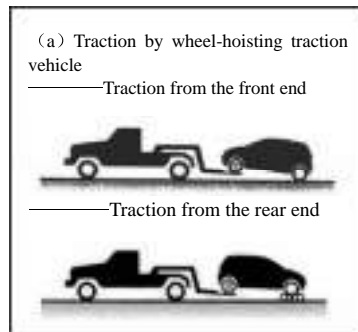

a)To tract through wheel-lifting tractor

Traction from the front end:

To free from parking brake

Traction from the rear end:

It is recommended to use traction trolley under front wheel.

To convert engine switch to ACC mode and place gear level to neutral gear in the event that traction trolley is idled.

Notice

To assure sufficient ground clearance of automobile landing end while hoisting wheel, otherwise automobile may be damaged during the traction process.

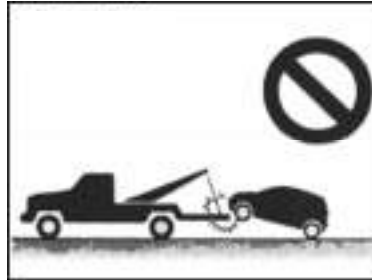

(b) By flat trailer

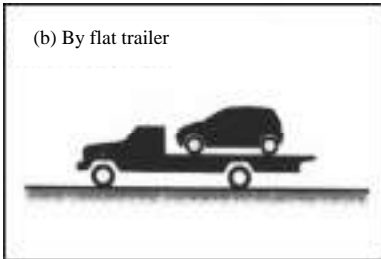

b)Traction through flat bed trailer

Notice

Do not adopt sling-type trailer while dragging automobile, or the automobile body will be damaged.

Notice

Do not adopt sling-type trailer while dragging automobile, or the automobile body will be damaged.

—Emergency towing

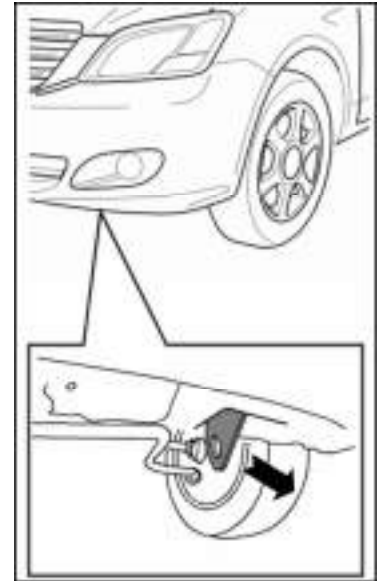

Front hook

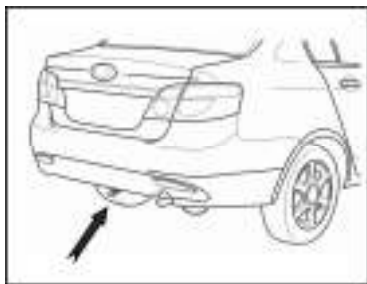

Rear hook

You should call professional service institutions for automobile traction. In the event of emergency but no support from professionals, you can temporarily adopt ropes to tow your automobile through traction hook in front of automobile or emergency traction hook underneath and in the rear of the automobile, and you should be cautious while towing your automobile. In the event of emergency traction,

there should be one driver in the car to control direction and brake. Emergency traction should be conducted on hard roads, with low speed and short traction distance. In addition, wheel, axle, drive system, steering system, and brake system should be in favorable condition.



Warning

To be cautious in the event of emergency traction, abrupt start is not allowed. In addition, automobile should stably run, or it may bring overlarge stress to hook and traction ropes or chain, in a bid to result in damage to traction facility and automobile.

Notice

◆ To adopt special rope or chain for automobile traction, with rope or chain being firmly fastened.

Prior to traction, you should release parking brake and place gear at neutral gear, with key being placed at “ACC” place.

—Warning triangle

In the event of automobile trouble, you should adopt triangle warning board, and its usage is shown as follows:

- 1.To open protection box and take out folded triangle warning board.
- 2.To pull upward the left & right edge of triangle and lock the top.
- 3.To simultaneously move the four

steadying bar along the bottom of triangle hemline, in order to make the hemline of two square blocks for fixing steadying bar parallel with triangle hemline.

4.To open two steadying bars on the left and right side through turning forward or backward, thus triangle warning board's overall frame will be formed.

5.To put triangle warning board at the back of parked automobile (about 50m-150m away), with reflecting face towards the coming vehicle and parallel with driving direction.

6.Triangle warning board can send warning signal, implying that there are troubles in parked vehicle.

Special hint: Driver should turn on hazard warning signal lamp before placing triangle warning board.

Chapter 5

Antirust and Appearance Care

—Antirust

During automobile driving process, you should conduct reasonable anti-rust maintenance to your automobile, in order to improve your automobile's anti-rust ability.

Main Erosion reasons for automobile:

- While automobile is running on roads, salt, dust, and water vapor may be accumulated on the parts that are difficult to be cleaned.
- Paint layer or lower coat have been scratched due to little accident or gravels on road.

In the event that you are living in special region or always drive on

special environment, you should cautiously protect your automobile.

- Chemical ingredient of salt and dust on road will accelerate the rusting to your automobile, for instance, the salt content is comparatively higher in coastal areas or the areas with severe industrial pollution.

- In the event that temperature is right higher than freezing point, humidity will help accelerate the rusting process.

- Most of components should be work under dry environment, some components working in humid environment subject to rusting.

- Some components are working in

the environment lacking ventilation, and high temperature will accelerate the rusting.

According to above analysis, we can conclude that drivers should maintain cleaning to automobile (especially the automobile bottom) as much as possible, and they should paint the damaged parts for protection.

To achieve the goal of rust resistance, you should follow the following regulations:

It is a must to regularly clean automobile. In addition, you should follow the regulations below, in order to resist rust:

- In the event that you always drive

in regions with high salt in air or you are living in coastal region, you should clean the automobile bottom once a month at least, in order to reduce rusting risk.

●To clean automobile bottom, you can use high-pressure water or vapor. As to invisible parts or dust-accumulation parts, if you have wetted these parts by water or vapor, but these parts are still unclean, which is unfavorable for rust resistance. In addition, water in the drain holes of different parts (like lower brim, lower girder, and vehicle girder) should not be reserved due to dust blocking, because it may lead to rusting.

●To thoroughly clean up automobile bottom after the winter. Please refer to “Cleaning and Waxing” below for detailed information.

Examination and repair of

automobile paint condition

To duly supplement paint in the event of paint scratch, in order to guard against rusting from the scratch. In the event that the scratch has extended to metal layer and sheet metal parts have been exposed, you should duly call Designated workshop for maintenance.

Examination of automobile inside
Water or dust may be accumulated under the floor coverage layer, and they may lead to rusting in the event of delayed cleaning. Therefore, you should irregularly examine and dry the floor coverage layer. In the event of transporting chemicals, cleanser, chemical fertilizer, or salt, you should adopt appropriate containers, and duly adopt cleaning & drying measures in the event of liquid splash or leakage.

Automobile should be parked in the garage with sound ventilation or the

area with roof instead of the humid and sealed garage.

In the event that you are washing automobile in garage or parking the automobile caught in rain or snow in garage, the humidity in garage will increase, which may lead to rusting. In the event of high temperature in garage, your automobile can still be rusted due to poor ventilation.

——Flushing and waxing

Automobile washing

Regular washing and maintaining clean

In the following cases, paint's protection function may decline, which may lead to automobile body and components damage, thus you should duly clean your automobile:

- o drive in coastal regions
- o drive on the road painted with

antifreeze.

- o be stained with coal tar, bird feces, and insect body.
- o drive on the areas containing smoke & frog, coal smoke, dust, metal powder, and chemical substances.
- o be stained with mud and dust.

Manual cleaning

Manual cleaning should be conducted in cool place while the automobile temperature declines to hand-touchable temperature.

Notice
To be cautious while cleaning the bottom of automobile floor or the chassis, in order to prevent arms from being injured.

1.o use water pipe to wash away floated dust and clean up the mud or salt & alkali at the bottom of automobile or on wheels.

2.o clean automobile with special automobile cleaning soap, and cleaning agent proportion should be based on special soap instruction. In addition, you can dip cleaning agent by cotton gloves for cleaning, but you should moderately wipe the automobile.

Plastic wheel decoration cover: Plastic wheel decoration cover subjects to rusting of organic substances, thus you should duly clean up the decoration cover and check if it is damaged in the event that organic substances have been splashed to the cover.



Warning
Do not use damaged wheel decoration cover, in order to guard against accidents due to cover falling.

Aluminum wheel rims: to be

washed with moderate cleaning soap or neutral cleaning agent.

Plastic bumper: To be prudential in cleaning, and hard cleaning tools is forbidden due to soft bumper surface.

Be stained with asphalt: To clean up with turpentine or other innocuous oil paint.

Notice
Do not clean your automobile with gasoline or solvents featuring strong dissolution performance because these solvents may be toxic or harmful to the automobile.

3.horough cleaning: cleaning soap will lead to stains on the automobile after being dried, thus you should immediately wash the automobile with water after washing by cleaning soap. Thorough cleaning is

needed especially in summer.

4.0 guard against water stains after washing, you should use clean and soft cotton cloth to dry the automobile after cleaning, but overexerting is not allowed, because it may scratch the automobile.

Automatic cleaning

Automobile can be cleaned on automatic cleaning line, but the bush and unfiltered water may scratch the automobile during the washing process and reduce paint's endurance and finish degree (especially to the dark paint). Therefore, you should confirm if the automatic cleaning caters to your automobile, and car-cleaning operators should bring forward their proposals to drivers.

Notice

To guard against damage to antenna, you should dismantle antenna before the automatic cleaning.

Wax automobile

To keep the automobile surface bright and clean, the automobile shall be polished and waxed.

In the event of poor waterproof resistance, the automobile surface shall be waxed.

1.rior to wax, the automobile shall be cleaned and dried, even though the mixture of detergent and wax is used.

2.To wax the automobile with high-quality polishing agent. In the event that the automobile surface has been severely weathered, users shall firstly employ the auto cleaning polish, and then waxing shall be done independently. During

the polishing and waxing course, users shall strictly abide by the product instruction and notices offered by the polishing agent manufacturer. Also, the chrome-plating parts and painting part shall be polished and waxed as well.

3.If the water drops do not form on the automobile surface but there is large area of water mist, please wax again.

Notice

While repainting the automobile in high-temperature paint spraying waxing room, please remove the plastic bumper, or the bumper will be damaged.

Painting makeup

Painting makeup is used to revamp the slight scratch
The scratched or corroded parts

shall be duly revamped. For assuring the effect of painting makeup, please use little painting brush and pay attention to the brushing direction. In addition, the parts for painting makeup shall be kept dry and clean. Painting makeup is of high technique, and little painting shall be used to only revamp the damaged part and keep other parts free from the painting.

—Cleaning inside of your car

Warning

Do not directly wash the vehicle floor with water or let the water fall onto the floor while cleaning the automobile inside and outside because the water on the floor will enter the acoustic system or other electrical parts

under the carpet, which will exert influence on the these parts' normal operation, or lead to the body corrosion.

Interior Decoration

Please clean floating dust in interior decoration, and then swab the dirty surface with cloth wetted by warm water. While cleaning, please use the special detergent and strictly follow the user instruction offered by the manufacturer.

Notice

Do not use solvent, paint thinner, gasoline and glass cleaner while cleaning the interior decoration.

Carpet

Please frequently clean dust on the carpet with the cleaner because too many dusts will lead to carpet

damage. Please periodically clean the carpet with detergent to prolong its service life. In addition, please use the foam detergent on sales, which shall be used with sponge or soft brush according to the detergent's user instruction. To keep the carpet dry, do not add water into the foam detergent.

Safety Belt

The safety belt can be cleaned with mild non-detergent soap, cold water and tepid water.

Moreover, the cotton cloth and sponge can also be used for cleaning the safety belt, but users shall notice if the safety belt has been over worn or cut.

Notice

◆ Do not use bleach or cleaning solution to clean the safety belt, or the intensity of safety belt will be weakened.

◆ The safety belt shall not be used until being dried naturally.

Window

Please clean the window outside with glass detergent on sales, and then dry the glass with soft cloth or paper towel.

Notice

While cleaning the glass inside, do not scratch or damage the defrost cable in the rear window.

Cleaning of air-conditioning panel, auto acoustic system, meter panel, property box and switch

Use the wetted soft cotton cloth for cleaning.

Swab relevant parts with cold water or tepid water for cleaning the dusts.

Notice

◆ Do not use the organic solution (like solvent, kerosene, alcohol and gasoline etc.) or acid & alkali solvent for cleaning because these chemical substances will lead to relevant parts' fading, pollution and desquamation.

◆ In the event of using detergent and polishing agent, please confirm if they are free from above ingredients.

◆ The liquid surface detergent shall not be sprayed on the surface of the interior decoration because it contains above organic ingredient. Please clean the liquid surface detergent as soon as possible if being sprayed to the surface of the interior decoration.

Please contact local Designated workshop for any questions concerning automobile cleaning.

Chapter 6

Maintenance Requirements

—Scheduled maintenance

We urge you to ask professional personnel for maintenance help in accordance with the maintenance schedule. In addition, the maintenance is favorable for:

- Improving the fuel economy
- Prolonging the automobile's service life
- Enjoying drive
- Improving safety
- Advancing reliability
- Prolonging time between failures
- Passing relevant national standards

We have fully considered driving economy and maintenance economy in the automobile design. For instance, lots of maintenance items required in the initial stage need not be maintained or the maintenance frequency can be reduced. Therefore, please strictly fulfill the maintenance schedule to ensure your automobile's economy. Please refer to the *chapter 9*.

Where for maintaining?

Please drive your automobile to local Designated workshop for maintenance.

Technicians of the Designated workshop once received professional training, thus they can

provide you with the best maintenance service.

The Designated workshop invested much in special maintenance facilities and equipments, in order to ensure the maintenance quality and save users' expenditure.

The Designated workshop can reliably and economically offer all items and services involved in the maintenance schedule.

Which maintenance items for DIY?

If you have some maintenance knowledge and basic maintenance tools, you can complete several maintenance items independently. Please refer to Chapter VIII for

relevant information.

However, some maintenance items require special tools and operating technique; thus, please turn to professional technicians for help. If you are experienced machinist, we also recommend that you should turn to Designated workshop for maintenance service because they will record the maintenance and the record will offer reference to your automobile's repair guarantee.

Time interval specified in the maintenance schedule is recorded according to mileage or time, and the implementation of maintenance is based on the expiry date.

Hoses (like air-conditioning system hose, brake system hose and fuel system hose, etc.) shall be examined by professional technicians according to the maintenance schedule.

The hose maintenance is very

critical. In the event of hoses aging and damage, please duly replace them. Note: hoses will get aging as time goes by, which may lead to expansion, wear, and crack.

——Does your car need servicing?

Please pay attention to changes in automobile performance, sound and visual signal and these changes will inform you if the automobile needs maintenance service. Of which, some important information is as follows:

- The engine is out of work, suffers unsteady running, or has abnormal sound.
- Power decline
- Abnormal noise
- Water leakage under the automobile (drop water from air

conditioning is normal).

● Change of exhaust sound, which may indicate CO leakage. Please open the window and check the exhaust system while driving the automobile..

● Insufficient tire pressure; Abnormal sound of tire while turning; irregular tire wear.

● When driving on straight and flat road, the automobile is inclined to one side.

● Abnormal sound from the running suspension system

● Brake performance declines, the brake pedal or the clutch pedal becomes soft, and the pedal will be closed to the floor, as well as braking deviation.

● The temperature of engine coolant is always higher than normal value.

The above problems indicate that

your automobile shall be readjusted or maintained, and please call the *Designated workshop* .

 **Warning**

In the event of finding problems, please do not drive the automobile before the careful examination, or the serious casualty may take place.

Chapter 7 Maintenance DIY

—Engine compartment schematic (TJ7133 Series)

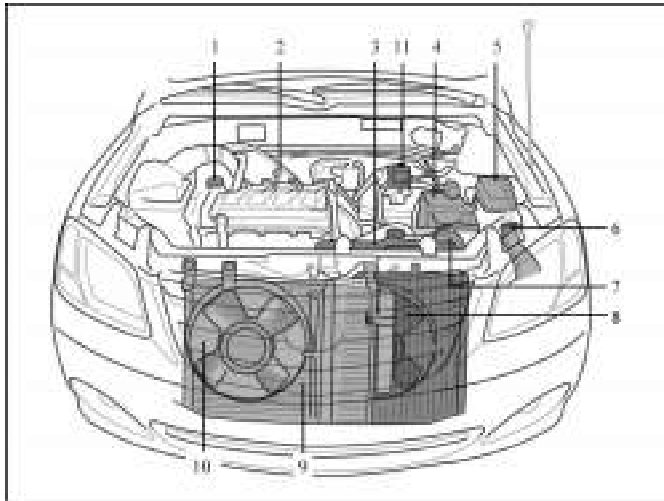

1. Oil Filler
2. Oil Level Gauge
3. Radiator
4. Accumulator
5. Relay Box
6. Detergent Tank
7. Engine Coolant Tank
8. Radiator Fan
9. Condenser
10. Condenser Fan
11. Brake Fluid Tank

—Engine compartment schematic (TJ7103 Series)

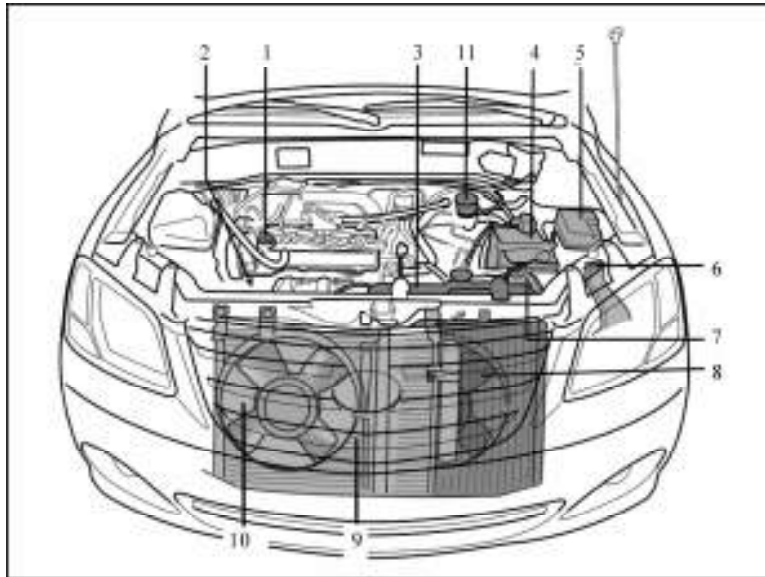

1. Oil Filler
2. Oil Level Gauge
3. Radiator
4. Accumulator
5. Relay Box
6. Detergent Tank
7. Engine Coolant Tank
8. Radiator Fan
9. Condenser
10. Condenser Fan
11. Brake Fluid Tank

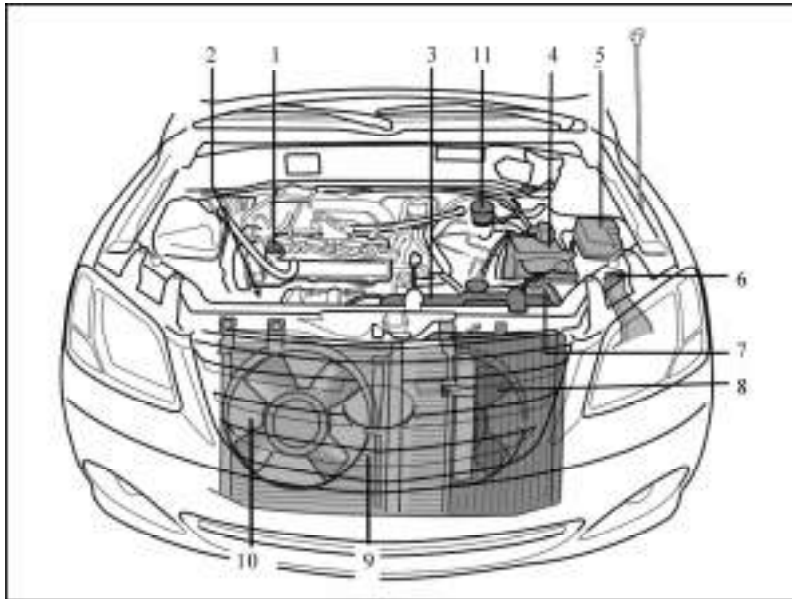

1. Oil Filler
2. Oil Level Gauge
3. Radiator
4. Accumulator
5. Relay Box
6. Detergent Tank
7. Engine Coolant Tank
8. Radiator Fan
9. Condenser
10. Condenser Fan
11. Brake Fluid Tank

—Locations of fuses

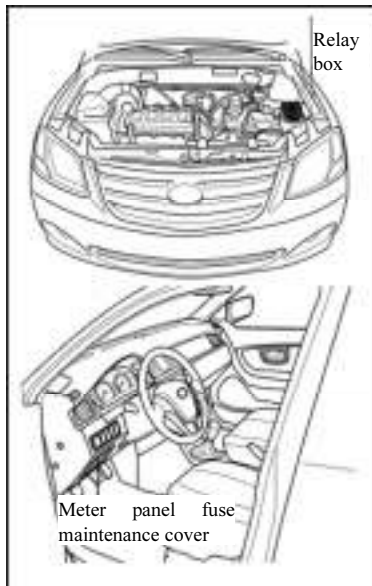

—Precautions for maintenance DIY

Please follow steps in the chapter before the operation.

Improper or incomplete maintenance will lead to problems in your driving.

This chapter only provides you with relatively simple self-maintenance items, and many operations shall be fulfilled by professionals with professional tools as mentioned in Chapter VI.

To prevent accidents, you should be cautious while maintaining the automobile, and please pay attention to the following items:

Warning

- Make sure that your hands, hair, clothes, tools keep away from the rotating fan and engine belt when the engine runs (better take off ring, watch, and tie, etc.)
- After the engine starts, the engine, radiator, exhaust manifold and spark plug root in the compartment will become hot, thus you shall keep away from them, so do the oil, coolant, and spark plug.
- When the engine is in thermal state, do not open the radiator cap or loosen the drain valve, in order to prevent being scalded.
- Not smoke, spark and fire near the fuel oil or accumulator because they will generate combustible gas.
- Be cautious of the accumulator because it contains poisonous and corrosive acid liquid.

●While the jack supports the automobile, no person is allowed underneath the automobile. The automobile shall be supported by hoisting platform & frame or other firm objects.

●While working near the electric cooling fan or radiator hood, the ignition switch shall be placed at “OFF” position. If being placed at ON position, the cooling fan will automatically rotate when water temperature in the engine or surrounding air temperature is too high.

●If you work at the place subjects to liquid splatter, drop, and spray in or outside of the vehicle, please use the eye protection device.

●Used engine oil contains potential toxic substance, which will cause the skin disease like skin allergy and skin cancer.

Therefore, you shall not lay the used engine oil aside for a long time or frequently touch it. If the waste engine oil is splattered to the skin, please clean the skin with soap and water.

●Do not place the waste engine oil at the place accessible to children.

●Please only use safe and appropriate means to process the engine oil cleaner and waste oil instead of dumping them into household garbage, sewer or floor.

●In the event of injecting brake fluid into the fluid reserve tank, you shall be cautious because the brake fluid will do harm to eyes or damage the paint surface. If the brake fluid splashes into eye, rinse the eye with clean water.

Notice

◆ The accumulator cable and ignition cable carry HC and HV, thus short circuit shall be prevented.

◆ In the event that coolant overflows, please clean it with water, in order to protect the parts & components and the surface coating.

◆ Keep the spark plug hole free from foreign bodies or dirt.

◆ Do not remove the positive and negative electrode of the spark plug.

◆ Do not inject too much gear oil, or the drive system may be damaged.

◆ If the brake fluid overflows, please clean it with water, in order to protect the parts & components and surface coating.

◆ Do not operate engine without air cleaner, or the engine damage will be accelerated.

◆ Be cautious of the frame of the screen wiper because it may damage glass surface.

◆ Please check if articles (like tools and dishcloth) are left before closing the engine compartment cap.

—Checking engine oil level

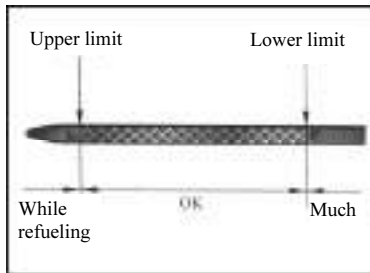

Turn off the engine at the normal work temperature, and examine the oil level by oil lever gauge

1.To accurately measure the oil level, please park the automobile on horizontal road, and wait for several minutes after turning off the engine, in order to make oil return to the engine bottom along the tube.

2.Take off the oil lever gauge, and clean it with dishcloth.

3.Insert the oil lever gauge back.

4.Take off the oil lever gauge again, and examine the oil level.



Warning

Keep away from the hot exhaust manifold

In the event that the oil level stays below or is slightly higher than the lower limit, please inject the same type of engine oil.

Open the oil filter cap; fill a small amount of engine oil every time and examine the oil lever gauge until the oil level stays between the upper limit and lower limit of the oil lever gauge.

After the oil level meets requirement, install the oil filter cap and tighten it.

Notice

◆ Prevent the engine oil from overflowing, or the engine will be damaged.

◆ Check the oil level in the wake of filling the engine oil.

—Checking engine coolant level –

Examine the transparent coolant tank when the engine is in cold

condition, and the coolant level shall stay between the upper limit and lower limit. In the event of the coolant level is too low, please fill glycol coolant, and such kind of coolant can prevent the aluminum products in the automobile from being corroded.

The coolant level will alter with the engine temperature, and when the fluid level stays below or is slightly higher than the lower limit, please fill the coolant until the level is close to the upper limit.

In the wake of filling the coolant, the fluid level lowers in short time, implying that leakage exists in the system. Now, please check the radiator, hose, coolant filter, radiator cap, drain valve and water pump

If users fail to find the leakage, please call Designated workshop to examine the pressure of the radiator

cap or the entire cooling system.

 **Warning**

Do not open the radiator cap when the engine temperature is relatively high, in order to prevent being scalded.

Selection to the coolant

The inappropriate coolant will lead to the damage to the engine's cooling system, but the glycol coolant can protect the engine's aluminum parts. Apart from frost resistance, the coolant can prevent the engine from being damaged and corroded. Users should not use redundant inhibitor and additives.

Please carefully read the instruction on the coolant vessel, and strictly abide by the *User Manual* to mix certain proportion of water (purified water or distilled water). Please

refer to Chapter VIII for the capacity of the cooling system. Users should use 50% solution, with minimum work temperature -35°C . In cold region, users can use 60% solution, with the minimum temperature hitting -50°C . Do not use more than 70% coolant for achieving better cooling effect.

Notice

Do not use ethanol coolant or only use the water.

—Checking tire pressure

The tire pressure shall comply with the standard.

Please refer to Chapter VIII for the tire pressure and model

The tire pressure shall be examined once every two weeks; do not forget

to examine the spare tire.

Improper tire pressure will exert negative influence on tire service life and drive safety.

Much low tire pressure will lead to tires over wearing, heavy steering and decline of the fuel economy, as well as tire burst due to the high temperature. In addition, much low tire pressure will decrease the air impermeability, which will lead to tire deformation and out-of-control drive.

Much high tire pressure will exert influence on drive comfort and maneuverability, and tire's central part closed to the floor will be over worn, thus the tire will subject to damage while driving across the poor road.

In the event that the tire should be frequently aerated, please call Designated workshop for examination.

Notices in examining the tire pressure:

●The tire pressure value is effective only when the tire is in the cold condition.

When the automobile parks for three hours or runs for less than 1.5km, the pressure reading is relatively accurate.

●Special tire barometer shall be used for testing the pressure. Eye estimate to tire will lead to the mistaken judgment to the pressure, and little difference of the tire pressure will reduce the maneuverability and drive comfort.

●Do not inflate or deflate the tire immediately in the wake of driving. The tire pressure is relatively high after driving.

●Make sure the tire is equipped with valve cap. The valve cap is used to prevent the

tire from deflating due to the entry of impurities and water drop. If the valve cap is lost, please purchase a new one.

—Checking and replacing air cleaner

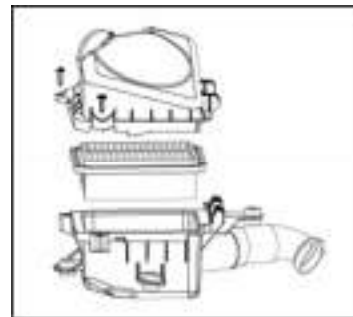

Please check and replace the air cleaner according to the time and mileage requirements specified in the *Quality Maintenance Manual*. While replacing the filter element

of the air cleaner, please clean the cleaner box together.

⚠ Warning

Do not drive the automobile without the air cleaner, or the engine wear will be accelerated, and the backfire may lead to fire disaster in the engine compartment.

—Checking and replacing tires

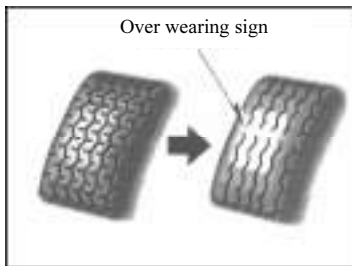

Check Tire

Check tire's sign of wear, and when the sign of wear indicates "overwear", please replace the tire. The sign of wear is embedded in the tread of the automobile tire, in order to facilitate users to know when to replace the tire. In the event that the tire thickness has been worn to 1.6mm or less, the sign of wear will appear. If the sign of wear appears on two or more tread veins, the tire should be replaced. Thin tread thickness will lead to automobile slippage and danger.

In the event that the thickness of the tread of the snow tire stays below 4mm, the snow tire will lose utility. Please periodically check if the tire has rupture and crack. Once there is damage, please immediately find professionals to revamp or replace the damaged tire.

Professionals can find tiny damage.

If there is foreign body in the tire, the tire inside may be damaged.

If the tire's service period exceeds six years, you should have it checked by professionals regardless of no eye-catching damage on it.

The tire (spare tire or new tire) will become aging as time goes by.

Tire replacement

In the event of replacing tire, you should use the tire whose size and structure are equivalent to original one, and bearing capacity equivalent to or larger than the original one.

In the event of using different models and sizes of tires, different indexes of the automobile will be greatly influenced, such as maneuverability, comfort, reading of speedometer or odometer, ground clearance, and the clearance between vehicle body and the tire.

In the event of installing the tire on

the rim, you should make the “DOT” word on the tire face outward.

 Warning

- Do not use the diagonal tire and radial tire on the vehicle at the same time, or the vehicle maneuverability will be influenced and steering may be out of control.
- You shall use the tire or wheel specified in the manual.

—Tire swap during use

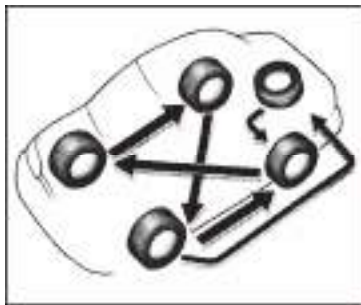

To even the tire wear and prolong the tire's service life, we recommend that the tire shall be replaced every 10000km. Of course, the replacement period can be adjusted according to driving habit and road condition.

Please see Chapter IV “Flat Tire” for the tire replacement procedures. In the event of replacing tire, please check if there is damage or uneven

wear on the tire. In general, abnormal wear arises from inappropriate tire pressure, inaccurate wheel alignment, unbalanced wheel, or sudden braking.

—Installing snow tires

Using snow tire and tire chain driving on snow land or icy land. On the wet or dry road surface, ordinary tire has better adhesive force than snow tire.

Selection to snow tire

In the event of using snow tire, you should select the snow tire whose size, model, and bearing capacity is the same as original tire.

Please check local management regulations while installing the snow tire, and do not install the stud tire restrained by local management regulations.

Installation of snow tire

If a snow tire is to be installed, four wheels should be installed with the same to ensure safe driving. Only snow tires of the same brand, specification and type can be used

In the event of installing the snow tire only on the front wheel, the difference of the adhesive force between the front wheel and the rear wheel will become large, which will lead to the runaway automobile.

While being idled, please keep the snow tire on the dry and shadowy site.

Please follow correct direction to align the tire, and install correctly the tire while replacing tire.

Warning

- Do not use the snow tire with inappropriate inflation pressure.
- Please read carefully the instruction concerning the snow tire's maximum speed and speed limitation on road.

Select tire chain

Select tire chain of proper size

Different areas and road conditions require differently for tire chains, which should be checked before installation

Installation of tire chain

The tire chain should be installed on front wheels as tightly as possible. Don't use tire chains on back wheels. The chains should be tightened after driving for 0.5-1.0km

Strictly observe the instructions of

tire chains by manufacturer during installation

Using tire chains may damage tires, wheels, hanger bracket and body of automobile, thus with tire chains should be selected for use. When using tire chains on automobiles with wheel discs, the discs may be scuffed by chain belt, therefore, the wheel discs should be removed before installing tire chains.

Warning

- The automobile speed should not exceed 30km/h or the limited speed recommended by tire chain manufacturer. Automobile speed should be below limited speed in whatever conditions.
- Drive carefully to avoid bump, cavity. Don't take a sudden turn, preventing automobile jump and shake.

● Avoid fierce step on brake causing wheel lock. tire chains will bring bad influences to automobile operation.

— Replacing wheels

Time for wheel replacement

In the event that the wheel suffers distortion, crack, or severe corrosion, the wheel shall be replaced.

If the damaged wheel was not replaced duly, the outer cover may fall off the wheel or the steering may be out of control.

Selection to wheel

While replacing the wheel, please ensure that the new wheel has the same bearing capacity, model, rim width, and offset as original one.

Please call *Designated workshop* for the correct wheel installation method.

In the event that the wheel size and model are different, the following factors will be influenced, such as maneuverability, service life of wheel and bearing, cooling of the brake, alignment of the speed meter /odometer, braking capacity, lighting distance of the front lamp, the height of the shock absorber, automobile's ground clearance, and the clearance between the tire and the body or the chassis.

While replacing the wheel, please do not use the second-hand wheel because the second-hand one lacks safety guarantee. If the distorted wheel has been repaired in surface, it cannot be used again because its internal structure has been damaged.

— Precautions for use of aluminum wheels

● After the automobile runs for the first 1600km, please check if the wheel nuts are loosened.

● In the event of adjusting, repairing and replacing tire, please check if the wheel nuts are loosened after the automobile runs for the 1600km.

● Please select the special nuts for Designated workshop's wheel as well as the special wrench designed for aluminum wheel.

● In the event of dynamic balance, please make use of the special balance weight. In work, please use plastic or rubber hammer.

● Please periodically check if the aluminum wheel has been damaged, please replace it in the event of being damaged.

In addition, do not install tire tube to the leaked wheel without tire tube for continual use.

Do not use second-hand tire on the automobile

It is very dangerous to use the tire from unknown manufacturers.

You should replace all tires or replace at least two front tires or rear tires.

Please see Chapter IV “In the case of air leak from a tire” for the tire replacement procedures.

In the wake of tire replacement, please conduct wheel dynamic balance.

Unbalanced wheel will influence the automobile maneuverability and tire service life, thus dynamic balance of the wheel shall be frequently inspected because the wheel will tend to unbalance in the application course.

While replacing the tire without tire tube, the tire valve shall be replaced simultaneously.

—— Checking battery

Warning

Notices for the accumulator

The accumulator may lead to combustible and explosive hydrogen.

●Cautious: the accumulator may suffer short circuit in the event of incorrect tool application.

●No smoke and fire around the accumulator. The electrolyte contains toxic and corrosive sulfuric acid.

●Avoid the electrolyte to contact with eyes, skin, or clothes.

●Do not take out the electrolyte in the accumulator

●Protective spectacles shall be worn in the event of working near the accumulator.

●Children shall be kept away from the accumulator.

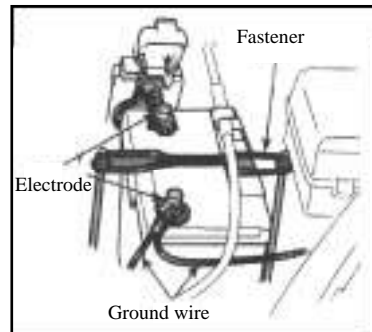

Check the accumulator outside

Check if the accumulator has been corroded, if the electrode is loosened and broken, or if the fastener is loosened.

a. In the event that the accumulator has been corroded, please clean it with warm water or daily soda water, in addition to coating lubricant at the electrode's external terminal to prevent the further corrosion.

b. In the event that the electrode is loosened, please mildly fasten the nut on the electrode.

c. Please mildly tighten the fastener on the accumulator, and excessive fastening force may lead to the damage of the accumulator shell.



Warning

◆ Please make sure that the engine and all accessories are closed prior to the maintenance.

◆ While checking the accumulator, Please firstly disconnect the ground wire from the negative electrode, and the ground wire shall be finally installed during the installation course.

◆ Do not place the metal tool or conductive articles near the accumulator's wiring terminal, in order to prevent the metal

articles from contacting with the accumulator electrode, or the short circuit will take place, and the accumulator and terminal may be damaged.

◆ The accumulator's air vent shall not be blocked; in winter, it shall not be blocked by the icy water, or the accumulator's internal pressure will ascend, which may lead to explosion of the shell.

◆ Do not use the method of short circuit to test if the accumulator is electrically active.

— Precautions for battery charge

While being charged, the accumulator will generate the hydrogen; therefore, prior to the charging:

1. In the event that the accumulator is charged in vehicle, please disconnect the ground wire.

2. While connecting or disconnecting the charger wire, please place the charger switch at the OFF place.



Warning

Please charge the accumulator in safe area, and do not charge it in garage or the room with poor ventilation.

Notice

◆ Do not charge the accumulator while the engine is running, and all accessory equipments shall be shut off during the charging course.

◆ If the vehicle has been idled for a long term, please take off the accumulator or disconnect the accumulator's lead at the negative electrode. While the accumulator has been idled, the accumulator shall be fully charged and its status shall be frequently checked. In the even that the voltage is low, please charge the accumulator in time.

◆ During the application course, do not overdischarge the accumulator. After being discharged, the accumulator shall be duly charged.

—Checking and replacing fuses

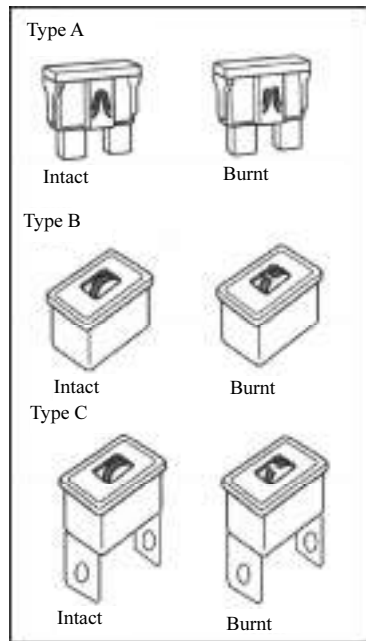

In the event that the front lamp or other electric appliances fail to work, please check the fuse. If the fuse has been burnt, please replace it with new quality fuse.

Please turn off the ignition switch and other idled electric appliances, and then directly take off the fuse for check.

Confirm the fuse in problem, and mark the name of the electric circuit where the fuse is located on the fuse box. Please see Chapter VIII of the Manual for the electric appliances controlled by every fuse.

Type A fuse can be taken out by special tool that was placed in fuse box in the engine compartment.

In the event that you are not sure if the fuse has been burnt, please replace a fuse that you considered intact.

If the fuse has been burnt, please insert a new one into original slot.

Only the fuse meeting the current stipulated on the fuse box can be installed.

In the event that there is no spare fuse, please take out the fuse at A/C in case of emergency, and such fuse is not necessary in normal drive, but it can be used if its current meets requirements.

If the fuse of the same model and size cannot be found, the fuse with relatively small rated current can be used, but it shall meet original rated current. If the new one's current is much lower than the rated current, the fuse may be burnt again; thus fuse meeting requirements shall be immediately found for the installation.

Users should purchase one set of spare fuse and put it in the vehicle for emergency.

If the new fuse has been burnt immediately, the power system

must suffer certain problem, and please call Designated workshop to handle the problem.

 **Warning**

Do not use the fuse whose rated current is larger than the stipulated current, or use other lead to replace the fuse, or severe damage and even fire disaster may take place.

——**Filling washer fluid**

If the washing fluid tank lacks the washing fluid, please infill the washing fluid in time.

The purified water can be used as the washing fluid. In cold region (with ambient temperature stays below freezing point), the washing fluid can be used as the antifreeze agent. Please purchase the washing

fluid from Designated workshop or from most of auto fittings stores.

Notice

If using the engine's cooling fluid or other alternatives, the paint on the automobile surface may be damaged.

——**Replacing bulbs**

Location of Front Lamp

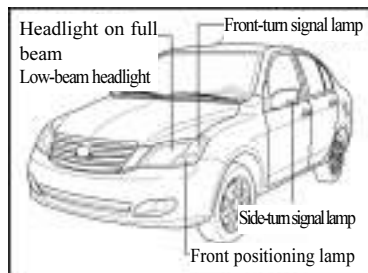

Location of Rear Lamp

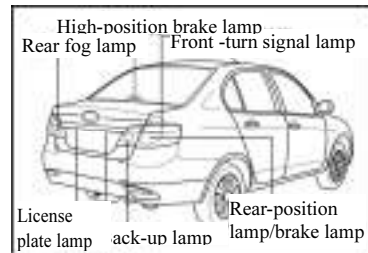

Please see content below for the common knowledge on the automobile lamps. While replacing the lamp, please confirm that the ignition switch and lamp switch are turned off, in addition, please use the lamp meeting rated power requirements in the table:

 **Warning**

Halogen lamp contains compressed air, thus when the lamp is broken or ruptured, the air will lead to explosion, the lamp fragments arising from the explosion may hurt people. Therefore, while holding the lamp, you should only hold its plastic or metal case, and do not contact other glass parts.

Notice

- ◆ You can only use the lamps listed in the table
- ◆ While disconnecting the joint or dismantling lamp socket, do not directly pull the wiring harness, or the insulated surface of the wiring harness may be subject to damage.

Lamp	Power: Watt	Type
Front lighting lamp	60/55	A
Front position lamp	5	C
Front-turn signal lamp	21	B
Side-turn signal lamp	5	C
Rear-turn signal lamp	21	B
Brake lamp/rear position lamp	21/5	C
Back-up lamp	21	C
High position stop lamp	16	C
Rear fog lamp	21	C
License plate lamp	5	C
Interior lamp	5	D
Trunk lamp	5	C

- A: H4 halogen lamp
- B: single-filament lamp (Amber)
- C: Wedge-type lamp
- D: Double-capped lamp

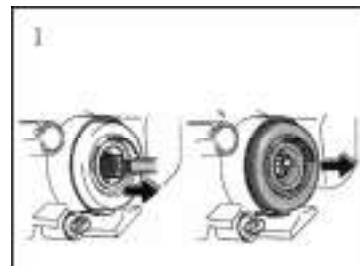
Front lighting lamp

1. Open the engine cover, disconnect the joint and take off the plastic hood. If the joint has been tightened, please turn it to right or left and then take off it.

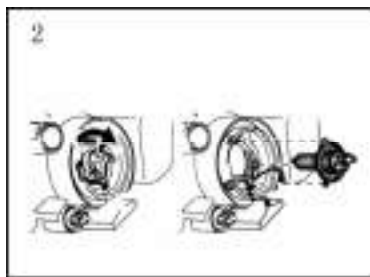

2. Loosen the lamp's locating spring, take out the lamp, and install the new lamp and the locating spring.

While installing the lamp, please follow the lamp's socket mark.

Do not touch the lamp glass with hand.

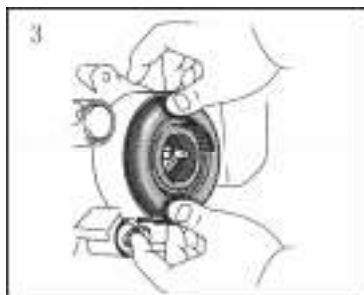

3. Install the rubber hood according to diagram, in order to make it contact with lamp holder case, and then connect the plug.

Make sure that the rubber hood contact with the socket and lamp holder case.

The light adjustment is not needed after reinstalling the light, and please contact Designated workshop if the light adjustment is a must.

Front position lamp

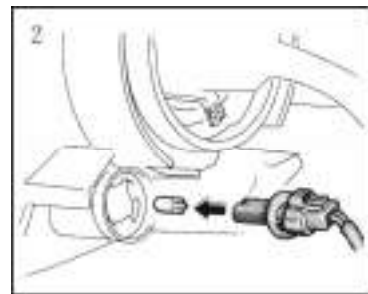

Front-turn signal lamp

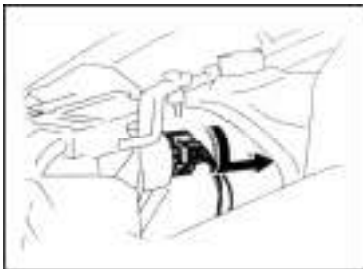

Open the engine compartment and follow the diagram to take off the lamp holder from the rear side of the assembled lamp, and then replace the lamp.

Rear-turn signal lamp, brake lamp and /rear position lamp

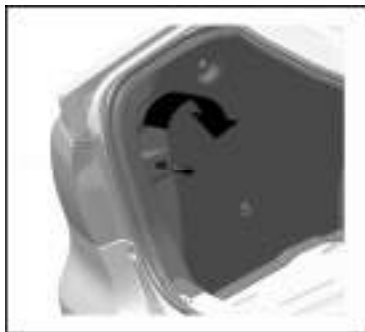

Dismantle nuts at the rear guard plate on both sides of the trunk, unveil the guard plate on the trunk's rear side to expose the rear part of the lamp.

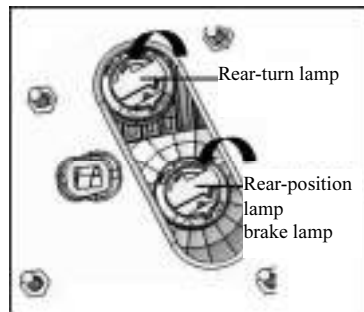

Please follow the diagram to dismantle the lamp holder and replace the lamp

Rear fog lamp (left side), back-up lamp (right side)

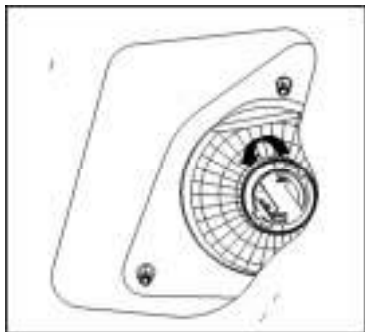

The rear fog lamp and back-up lamp are installed on the trunk cover, and open the trunk cover and dismantle the wiring harness connector and replace the lamp.

License plate lamp



Open the trunk cover and follow the diagram to turn the lamp holder counterclockwise and take off it, and then replace the lamp.

High position brake lamp



1. Take off the high position brake lamp according to the diagram



2. Dismantle the wiring harness socket



3. Replace the lamp

Side-turn signal lamp

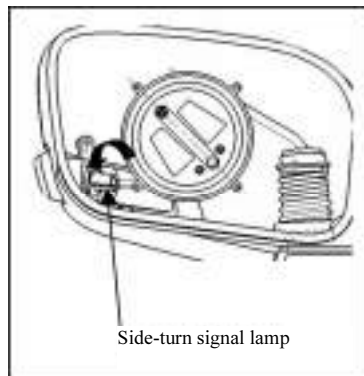

Side-turn signal lamp is integrated into external rear-view mirror. The lamp holder can be dismantled after the rear-view mirror has been dismantled, and the lamp can be replaced accordingly.

Chapter 8

Specifications and Service Data

—Model and features

Vehicle model	Body model	Transmission type and model	Engine type
TJ7103UE4S	Saloon	MT manual transmission 5T063A	CA3GA2+
			CA3GA5
TJ7103UE4O	Saloon	MT manual transmission 5T063A	CA3GA5
TJ7133UE4S	Saloon	MT manual transmission 5T065	CA4GA1
TJ7133UE4O	Saloon	MT manual transmission 5T065	CA4GA13
TJ7133UE5	Saloon	MT manual transmission 5T065	CA4GA1

—Vehicle parameters

Automobile model		TJ7103U	TJ7103UE4Q	TJ7133U	TJ7133U	TJ7133U	
		E4S		E4S	E4Q	E5	
Dimension parameter	Length	mm	4155				
	Width	mm	1645				
	Height	mm	1435				
	Distance between shafts	mm	2405				
	Front gauge	mm	1405				
	Track rear	mm	1385				
	Minimum ground clearance (full load)	mm	Full load 125±20				
Quality parameter	maximum total mass	kg	1280		1290		
	Maximum axle load kg	Front axle	645±3%		651±3%		
		Back axle	635±3%		639±3%		
	Complete vehicle kerb mass	kg	905		915		
	Complete vehicle kerb axle mass	kg	Front axle	530±3%		536±3%	
		kg	Back axle	375±3%		379±3%	
Performance parameter	Maximum speed	km/h	≥156		≥173		
	Starting acceleration capacity (0-100 km/h)	s	≤19.5		≤14		
	Maximum gradeability		30%		30%		
	Fuel consumption L/100km (test method GB/T 19233)		≤5.6	≤5.3		≤5.3	≤5.8
Discharge index			ChinaIV stage(GB 18352.3)		ChinaIV stage(GB 18352.3)	JingV stage	
The crew number			5				

—Engine parameters

Automobile Model		TJ7103UE4S		TJ7103UE4Q		TJ7133UE4S TJ7133UE5		TJ7133UE4Q	
Engine Type		CA3GA5 CA3GA2+		CA3GA5		CA4GA1		CA4GA13	
Form		Gasoline engine of orthostichous 3 cylinders, 4 strokes		Gasoline engine of orthostichous 3 cylinders, 4 strokes		Gasoline engine of orthostichous 4 cylinders, 4 strokes			
Cylinder diameter and stroke mm		76×73		76×73		73×80			
Output value ml		993		993		1339			
Rated power kW/r/min		50.5 / 6000		50.5 / 6000		67 / 6000			
Maximum net power kW/r/min		48 / 6000		48 / 6000		61 / 6000			
Maximum torque Nm/r/min		90 / 3600		90 / 3600		120 / 4400			
Valve clearance (cold state)	Intake valve	0.20±0.05		0.20±0.05		0.20±0.03			
	Exhaust valve	0.25±0.05		0.25±0.05		0.30±0.03			
Spark plug type		FR7DE	K5RTPP	FR7DE	K5RTPP	K20R-U11		K20R-U11	
						FR8LCX			
Spark plug gap mm		0.95~1.05	0.7~0.8	0.95~1.05	0.7~0.8	1.0~1.1		1.0~1.1	
Poly v-belt tension N		450±49 (new poly v-belt)		450±49 (new poly v-belt)		550±50		550±50	
		400±49 (old poly v-belt)		400±49 (old poly v-belt)					

Note:

New multi-wedge belt indicates the belt used on the running engine for less than five minutes.

Old multi-wedge belt indicates the belt used on the running engine for more than five minutes.

Engine lubricant:

Model	TJ7103UE4	TJ7103UE4S	TJ7133UE4 TJ7133UE4S
Total volume (L)	3.2		4.0
Mass and viscosity grade	API SJ or above 5W/30 or 10W/30	API SM 5W/30 or 10W/30	API SL 5W/40

Oil Viscosity Table of
Recommended Engine (SAE)

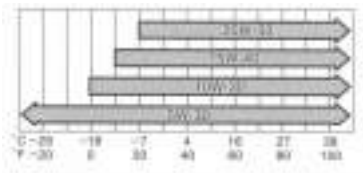

Cooling System

Total volume: 5.5L

Type of coolant: glycol coolant

The glycol coolant can protect the aluminum part of the engine.

Do not use ethanol coolant or water Fuel

Fuel type: RON No. 93 or above
Vehicle- Use Unleaded Gasoline.

As to E3 vehicle, National III Standard (OBD) special fuel shall be used.

As to E4 vehicle, National IV Standard special fuel shall be used. Rated volume of the oil tank: 37L While refueling, please correctly use the petrol gun. The petrol gun shall be fully inserted into the oil tank, and keep it upright on the rim of the refueling mouth. Once the petrol gun is automatically closed, the oil tank is full, and additional refueling is forbidden, or the oil

tank temperature will ascend, and the fuel will overflow the oil tank, which may lead to fire disaster or explosion.

—Battery

Charge current:

Fast charging, maximum 15A

Slow charging, maximum 5A

—Clutch

Pedal free stroke: (mm)

5T065 transmission: 5~15

5T063A transmission: 15~30

—Manual transmission

Transmission oil capacity: (L)

5T065 transmission: 1.8~2.0 L

5T063A transmission: 1.9~2.05 L

Transmission oil specification:

API GL-4, SAE: 80W / 90

In cold region, please select the lubricant with higher grade

Notice	
Do not use unqualified transmission oil, or the transmission will be damaged.	

—Braking

While the engine runs, use 500N of force to tramp brake pedal, and the reserve stroke between the pedal and the floor is not less than 65mm. Free stroke of the brake pedal: 1~5 mm

Use 200N of force to full the parking brake pedal, 4 to 9 clatters will be heard.

Brake fluid: HZY4 of GB12981-2003

(Manufacturer: Shenyang Original)

—Steering

Free stroke of the steering wheel 1~10 mm

—Tires

tire model:

TJ7103

Series:165/70R13(TJ7103UE4S);175/65R14(TJ7103UE4Q)

TJ7133 Series:175/65R14

Tire pressure:

As to regulated tire pressure, pls refer to tire pressure information plate on driver side door lock support

Tightening torque of the tire nut:103 N·m

Wheel dynamic balance requirements:

Residual dynamic unbalance value \leq 5g \circ (residual dynamic unbalance value: the allowable residual unbalance value after wheel balalnce counterweights)

—Fuses

In the engine compartment
TJ7103 Series

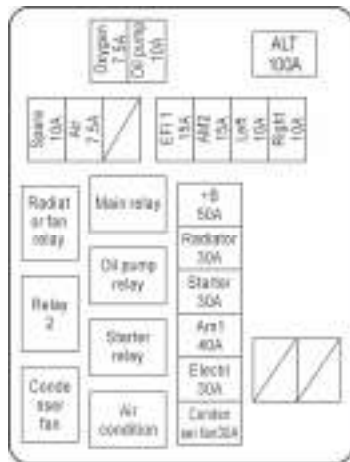

TJ7133UE4S
TJ7133UE4Q

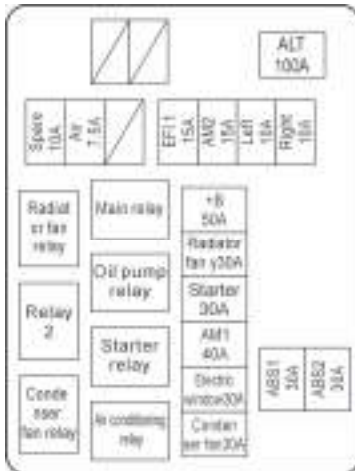

Notes: EFI insurance of vehicle

model TJ7133UE4S is 20A; EFI insurance of vehicle model TJ7133UE5S is 15A.

TJ7133UE4Q

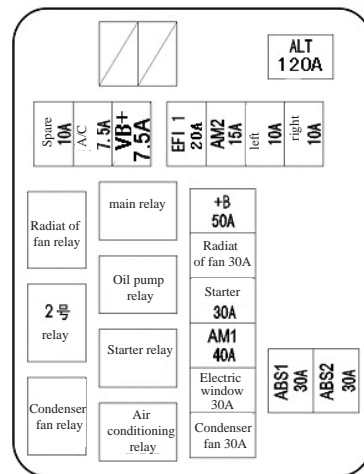

Underneath the Meter Panel TJ7103 Series

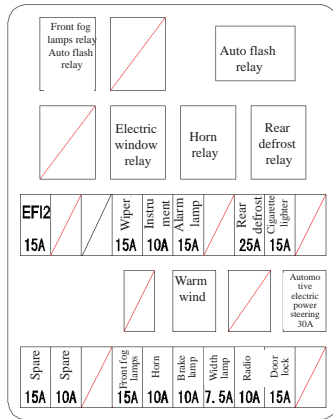

TJ7133UE4S TJ7133UE4Q

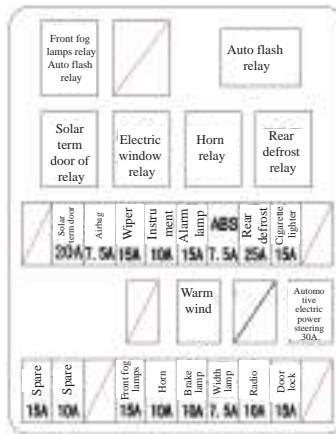

TJ7133UE5

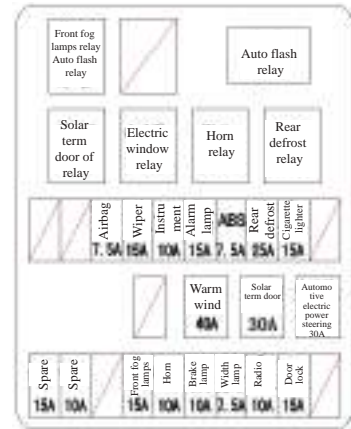

Note 1. Vehicles equipped with EPS have the EPS fuse

Note:1.Vehicles equipped with ABS have ABS fuse

2.vehicles equipped with airbag have the airbag fuse.

3.Vehicles equipped with EPS have EPS fuse

Notice

The fuse label in the user manual may be different from that of the customer vehicle due to design change; in this case, the fuse label on the vehicle shall prevail.

—Wheel alignment parameters

Front wheel alignment parameters	Kingpin caster angle	$2^{\circ} 55' \pm 45'$
	Wheel camber angle	$0^{\circ} 20' \pm 45'$
	Kingpin inclination angle	$12^{\circ} \pm 45'$
	Toe in (mm)	1 ± 1
Rear wheel alignment parameters	Wheel caber angle	$-0^{\circ} 40' \pm 45'$
	Toe in (mm)	$5 \begin{matrix} +3 \\ -1 \end{matrix}$
Body status in measurement	Vehicle height A—B(mm)	69.5 ± 15
	Vehicle height C—D(mm)	25 ± 15

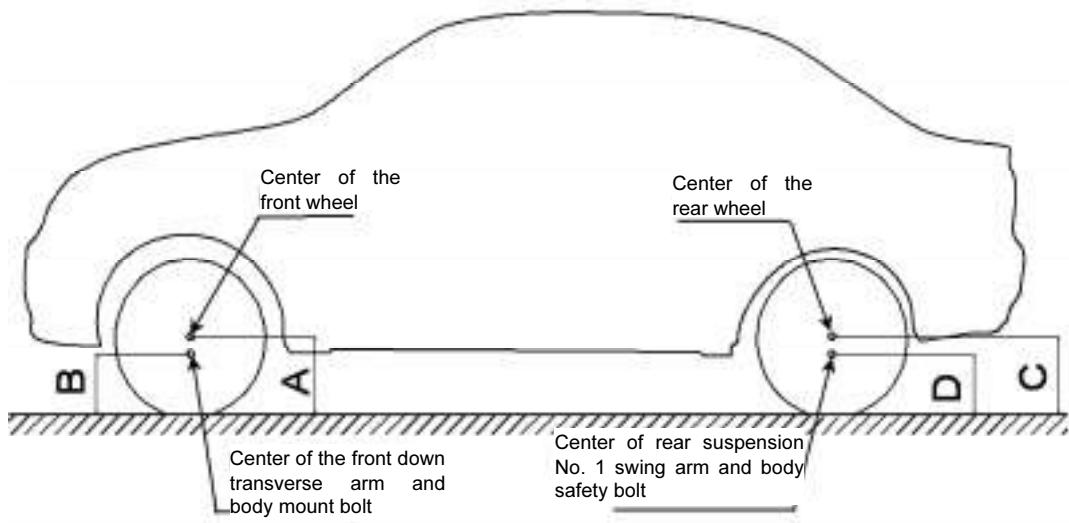

Note: Adjust the vehicle height in the “No Load” status, and the wheel position parameters measurement shall not be conducted until the A—B and C—D have been met. In addition, the measured wheel position parameters shall meet the stipulations of the wheel position parameters table.

Chapter 9

Regular Maintenance

——Maintenance meaning

First maintenance

For a new car, the first maintenance is extremely important, because it is closely related to the life of the car. Every new car must be first serviced after driving 1000~2000 km. Please bring your new car to an Designated workshop to do the first maintenance.

Periodical Maintenance

Periodical maintenance must be done every other 5000 km after the first service in Designated workshop, this is the prerequisite for your car to enjoy the warranty.

Maintenance is made for ensuring the driving comfort, safety and economy. Please have your car maintained regularly so as to make your car always be in a good condition.

The service interval for schedule of maintenance is

determined by the odometer reading or time interval, whichever comes first.

The service interval of each item can be obtained from the maintenance schedule.

The hoses (the cooling system and the heating system, the brake system and the fuel system) should be checked by the qualified technician according to the maintenance item. These items are the important maintenance items. If there is damage, replace it immediately. Please take care of the expansion, wear or rupture of the hoses due to aging.

In order to make your car remain in excellent technical condition, regular maintenance schedule and item are specified in this manual Please have your car serviced and maintained in Designated workshop according to all the specified items, the person at the service station would make records and testify all your maintenance. If

your car goes wrong, the maintenance records is one of the basis for claim confirmed by our company.

——**Check before travelling**

For safe and comfortable driving, the pre-starting check must be performed.

Weekly check

- Engine oil dirt and level
- Engine coolant level
- Brake fluid level
- Automatic transmission hydraulic fluid level
- Windshield washer fluid level

Monthly check

- Water pump, engine drive belt
- Battery electrolyte level
- Tire air pressure and wear
- Steering wheel
- Brakes
- Accelerator pedal move well or no

While driving slowly

- Speedometer and water temperature gauge
- Turning effort of steering wheel and whether the car is deviated
- Whether the front wheel is sideslip or wobble
- Whether the brake performance is normal or whether the vehicle is pulled to one side when the brakes are applied

Other inspection item

- Notice: eliminate fault in time if abnormal phenomenon occurs

Service must be done if one of the followings occurs:

- Engine stalling, stumbling or pinging
- Appreciable loss of power
- Strange engine noise
- Change in exhaust sound
- Tyre uneven wear
- Vehicle pulls to one side when driving straight on a level road
- Loss of brake effectiveness, spongy feeling brake or clutch pedal, pedal almost touches floor, vehicle pulls to one side when braking

- Engine temperature higher than the normal.

If you notice any of these clues, take your vehicle to Designated workshop.

——Maintenance schedule requirement

Your car needs to be serviced in accordance with the normal maintenance schedule (see **Maintenance Schedule**).

If you mainly operate your car under one or more of the special operating conditions below, some of the maintenance schedule items need to be serviced more frequently (see **Severe Conditions Maintenance Schedule**).

A . Road Condition

1. Operating on rough, muddy or melted snow roads.
2. Operating on dusty roads

B . Driving Condition

1. Towing a trailer, using a camper or car top carrier
2. Repeated short trips less than 8 km and outside temperature remains below zero.
3. Long idling or low speed driving for a long distance such as police cars, taxis or delivery cars.
4. Continuous high speed driving (80% or more of maximum speed) for over 2 hours.

—Table of scheduled maintenance

Maintenance Schedule(scheduled inspection)

1. Mileage and time calculate by whichever comes first
2. Recommend that cleaning the fuel supply system every 20,000 km.

Parts	Items	Content	Maintenance
Engine	Engine general condition	Starting performance , idling, acceleration performance, abnormal sound	First inspection at 1000km, second inspection at 20000km then Check every 20000km or Check once every year
		Exhaust	Check every 20000km or Check once every year
	Air filter	Clean, replace filter	Check every 5000km and Replace every 15000km
	Valve clearance	Check clearance	Check every 20000km or once every year
	Engine oil	Replace CA3GA2: API SJ or more CA4GA1: API SL	Replace every 5000km
	Oil filter	Replace	Replace every 5000km
	Fuel hoses and connections	Damage, oil leak	Check every 20000km or once every year
		Replace fuel hoses	Replace every 80000km or 48 months
	Fuel filter	Replace	Replace every 40000km or once every two years
	Engine cooling system	Replace coolant	Replace every 12 months
		Hoses and connection parts damaged, leakage	Check every 20000km or once every year
	Radiator cap	Function	Check every 40000km or every two years
Generator, water pump drive belt	Tension, cracks, damage	First inspection at 1000km, second inspection at 10000km then Check every 10000km or once every 6 months	

Parts	Items	Content	Maintenance
Engine	Timing belt(CA3GA2)	Replace	Mileage to 50000km inspect or replace the timing belt, mileage to 70000km timing belt must be replaced
	Timing chains (CA4GA1)	Check	Inspect every 50000km
	Ignition system	Spark plug gap, working conditions, clean and adjust or replace as necessary	Inspect every 10000km, replace every20000km.
		Initial ignition advance angle	Check every 20000km or once every year
Emission control system	Crankcase ventilation	Snorkel	Check every 20000km or once every year
	Carbon tank	Replace	Replace every 80000km
	Exhaust pipe	Exhaust pipe and tightening torque	Check every 20000km or once every year
Power train	Clutch	Free travel and reverse travel	First inspection at 1000km, second inspection at 10000km then check every 10000km or once every 6 months
		Working condition	Check every 20000km or once every year
	Clutch lines hoses and clutch fluid reservoir hose	Leak, fastening, damage	First inspection at 1000km, second inspection at 10000km then check every 10000km or once every 6 months
		Replace clutch hoses	Replace every 18 months
		Replace clutch fluid reservoir hoses	Replace every 24 months
	clutch master and release slave cylinder	Brake fluid leak	Check every 20000km or once every year
		Replace cup and dust cover	Replace every 24 months
	Transmission	Gear oil level and oil leak	Check every 10000km or once every 6 months
		Replace gear oil level	Replace every18 months or 30000km
		Control mechanism sound	Check every 40000km or once every two years
Drive shaft	Fasten connection part	Check every 20000km or once every year	

Parts	Items	Content	Maintenance
Power train	Drive shaft	Ball joint dust cover cracking and damaged	Check every 10000km or once every 6 months
		Pattern chain sound	Check every 40000km or every 2 years
		Ball joint sound	Check every 40000km or every 2 years
Suspension system	Spring	Damaged	Check every 40000km or every 2 years
	Fastening and connection parts	Fix and damage of the fastening parts	Check every 40000km or every 2 years
		Connection part abnormal sound	Check every 40000km or every 2 years
	Damper	Function, oil leak	Check every 40000km or every 2 years
Damage, abnormal sound		Check every 40000km or every 2 years	
Driving system	Tires	Pressure, wear and tear damage	First inspection at 1000km, second inspection at 10000km then check every 10000km or every 6 months
	Wheels	Tighten wheel nuts and bolts	Check every 20000km or once every year
	Front and rear wheel alignment	Sideslip measure	First inspection at 5000km, then check every 10000km
	Front and rear wheel bearings	Sound	Check every 40000km or every 2 years
Steering system	Steering wheel	Free travel, fastening, sound, movement	Check every 20000km or once every year
	Steering gear	Fastening, adjusting	First inspection at 5000km, second inspection at 40000km then check every 40000km
	Rod and the arm	Fastening, abnormal noise, damage	Check every 20000km or once every year
	Ball joint dust cover	Damage	Check every 20000km or once every year
	Knuckle	Joint part abnormal sound	Check every 40000km or every 2 years
	Front wheel	Wheel rotation angle	Check every 40000km or every 2 years

Parts	Items	Content	Maintenance
Brake system	Brake pedal	Free travel and reserve travel	First inspection at 1000km, second inspection at 10000km then check every 10000km or every 6 months
		Braking efficiency	First inspection at 1000km, second inspection at 10000km then check every 10000km or every 6 months
	Hand brake	Working stroke	First inspection at 1000km, second inspection at 10000km then check every 10000km or every 6 months
		Efficiency	First inspection at 1000km, second inspection at 10000km then check every 10000km or every 6 months
	Hand brake cable	Fastening ,noise, damage	Check every 40000km or every 2 years
	Brake lines and hoses	Leak, fastening, damage	First inspection at 1000km, second inspection at 10000km then check every 10000km or every 6 months
		Replace hoses	Replace every 18 months
	Brake fluid	Liquid level	First inspection at 1000km, second inspection at 10000km then check every 10000km or every 6 months
		Replace	Replace every 12 months
	Brake master cylinder, wheel brake cylinder	Brake fluid leak	Check every 20000km or once every year
		Replace cup and dust cover	Replace every 24 months
	Vacuum booster	Function	Check every 40000km or every 2 years
		Replacement of rubber parts and vacuum hose	Replace every 36 months
	Brake drum and friction films	Wear, damage, space	Check every 20000km or once every year
Brake disc and friction films	Wear, damage, space	Check every 20000km or once every year	
Proportional valve	Replace	Replace every 48 months	

Parts	Items	Content	Maintenance
Chassis and body	Doors and engine cover	Lock function, fastening, damage	First inspection at 1000km, second inspection at 40000km then check every 40000km or every 2 years
	Seat belt	Function, fastening	Check every 40000km or every 2 years
	Other	Lubrication of all parts of the vehicle body	Check every 20000km or once every year
Electrical system	Battery	Electrolyte liquid level, density	Check every 10000km or every 6 months
		Joint condition	Check every 10000km or every 6 months
	Harness	Joint part fastness and damage	Check every 40000km or every 2 years
	Lights, turn signals	Function	First inspection at 1000km, second inspection at 10000km then check every 10000km or every 6 months
	Horn, wipers, washer, defroster	Function	Check every 10000km or every 6 months
	Instrument	Function	Check every 10000km or every 6 months

Severe Conditions Maintenance Schedule

A-1 Operating on rough, muddy or melted-snow roads	
<input type="checkbox"/> Inspect brake drums and brake shoes	Every 10,000km or 6 months
<input type="checkbox"/> Inspect brake discs and pads	Every 5,000km or 3 months
<input type="checkbox"/> Inspect brake line pipes and hoses	The First 1,000km and every 10,000km or 6 months
<input type="checkbox"/> Inspect ball joints and dust covers	Every 10,000km or 6 months
<input type="checkbox"/> Inspect drive shaft dust cover	Every 10,000km or 12 months
<input type="checkbox"/> Inspect steering wheel linkage and steering gear box oil	Every 5,000km or 3 months
<input type="checkbox"/> Inspect front and rear suspension	Every 10,000km or 6 months
<input type="checkbox"/> Tighten bolts and nuts on chassis and body	Every 10,000km or 6 months
A-2 Operating on dusty roads	
<input type="checkbox"/> Replace engine oil	The First 1,000km and every 2,500km or 3 months
<input type="checkbox"/> Replace oil filter	Every 2,500km or 3 months
<input type="checkbox"/> Inspect air filter	Every 2,500km or 3 months
<input type="checkbox"/> Inspect brake drums and brake shoes	Every 10,000km or 6 months
<input type="checkbox"/> Inspect brake discs and pads	Every 5,000km or 3 months

B-1 Towing a trailer.	
<input type="checkbox"/> Replace engine oil <input type="checkbox"/> Replace oil filter <input type="checkbox"/> Inspect brake drums and brake shoes <input type="checkbox"/> Inspect brake discs and pads <input type="checkbox"/> Replace manual transaxle oil <input type="checkbox"/> Inspect front and rear suspension <input type="checkbox"/> Tighten bolts and nuts on chassis and body <input type="checkbox"/> Inspect clutch pedal	The First 1,000km and every 2,500km or 3 months Every 2,500km or 3 months Every 10,000km or 6 months Every 5,000km or 3 months Every 10,000km or 6 months Every 10,000km or 6 months Every 10,000km or 6 months The First 1,000km and every 5,000km or 6 months
B-2 Repeat short trips less than 8 km and outside temperature remains below zero	
<input type="checkbox"/> Replace engine oil <input type="checkbox"/> Replace oil filter <input type="checkbox"/> Inspect clutch pedal	The First 1,000km and every 2,500km or 3 months Every 2,500km or 3 months The First 1,000km and every 5,000km or 6 months
B-3 Long idling or low speed driving for a long distance, such as police car, taxi or delivery car etc.	
<input type="checkbox"/> Inspect brake drums and brake shoes <input type="checkbox"/> Inspect brake discs and pads <input type="checkbox"/> Inspect clutch pedal	Every 10,000km or 6 months Every 5,000km or 3 months The First 1,000km and every 5,000km or 6 months
B-4 Continuous high speed driving (80% or more of maximum speed) for over 2 hours	
<input type="checkbox"/> Replace manual transaxle box oil	Every 10,000km or 6 months



—Warranty record

Warranty Record

No.	Trouble Description	Date	repair manager

— **Maintenance record**

Maintenance after
travelling 1000-2000 km

Date:
Mileage:
Stamp of the Service Station
Next conventional Maintenance Mileage:

Maintenance after
travelling 5000 km

Date:
Mileage:
Stamp of the Service Station
Next conventional Maintenance Mileage:

Maintenance after
travelling 10000 km

Date:
Mileage:
Stamp of the Service Station
Next conventional Maintenance Mileage:

Maintenance after
travelling 15000 km

Date:
Mileage:
Stamp of the Service Station
Next conventional Maintenance Mileage:

Maintenance after
travelling 20000 km

Date:
Mileage:
Stamp of the Service Station
Next conventional Maintenance Mileage:

Maintenance after
travelling 25000 km

Date:
Mileage:
Stamp of the Service Station
Next conventional Maintenance Mileage:

Maintenance after
travelling 30000 km

Date:
Mileage:
Stamp of the Service Station
Next conventional Maintenance Mileage:

Maintenance after
travelling 35000 km

Date:
Mileage:
Stamp of the Service Station
Next conventional Maintenance Mileage:

Maintenance after
travelling 40000 km

Date:
Mileage:
Stamp of the Service Station
Next conventional Maintenance Mileage:

Maintenance after
travelling 45000 km

Date:
Mileage:
Stamp of the Service Station
Next conventional Maintenance Mileage:

Maintenance after
travelling 50000 km

Date:
Mileage:
Stamp of the Service Station
Next conventional Maintenance Mileage:

Maintenance after
travelling 55000 km

Date:
Mileage:
Stamp of the Service Station
Next conventional Maintenance Mileage: